



PRESENTED TO
CORNELL UNIVERSITY LIBRARY
WITH COMPLIMENTS OF
J. C. BRILL COMPANY.
CAR BUILDERS, PHILA

Cornell University Library

THE GIFT OF

J. G. Brill Co.

A. 1699.18.

7/8/03

Cornell University Library

arY896

The car-builder's dictionary;



3 1924 032 183 513
olin,anx



Cornell University Library

The original of this book is in
the Cornell University Library.

There are no known copyright restrictions in
the United States on the use of the text.

1895 EDITION

THE CAR-BUILDER'S DICTIONARY

+ AN ILLUSTRATED VOCABULARY OF TERMS
WHICH DESIGNATE AMERICAN RAILROAD
CARS, THEIR PARTS, ATTACHMENTS, AND
DETAILS OF CONSTRUCTION +

FIVE THOUSAND SIX HUNDRED EIGHTY-THREE ILLUSTRATIONS

COMPILED FOR THE MASTER CAR-BUILDERS' ASSOCIATION

By PROFESSOR JOHN C. WAIT, M. C. E.

ASSISTED BY

R. H. SOULE, *Superintendent of Motive Power, Norfolk & Western Railroad*; A. E. MITCHELL, *Superintendent of Motive Power, New York, Lake Erie & Western Railroad*; C. A. SMITH, *Master Car Builder, Union Tank Line.*

THE FIRST EDITION WAS COMPILED BY
MATTHIAS N. FORNEY, M. E.
AND ISSUED IN JANUARY, 1880

THE SECOND EDITION WAS COMPILED BY
A. M. WELLINGTON, C. E.
AND ISSUED IN DECEMBER, 1884

NEW YORK
THE RAILROAD GAZETTE, 32 PARK PLACE

1895

1

ACTION OF THE MASTER CAR-BUILDERS' ASSOCIATION.

At the Fifth Annual Convention, held in Richmond, Va., in 1872 it was

“Resolved, That a committee be appointed with power to publish an illustrated book, defining the proper terms or names of each and every part used in the construction of railway cars, and a description of the use of the same.”

At the Fourteenth Annual Convention, held in Detroit in 1880,

“The committee to whom was assigned the duty of preparing a Dictionary of Terms used in the Construction of Cars submitted a copy of the book and reported that they had finished their work, and were discharged.”

At a meeting of the Executive Committee held in Saratoga, June 17, 1892, Messrs. R. H. Soule, A. E. Mitchell, and C. A. Smith were requested to supervise the new edition (1895).

PREFACE.

The need of a Car Builder's Dictionary has been established by the earlier editions and its uses recognized by railroad men, so that its purposes require no explanation in this edition.

Since the last revision, in 1884, the changes in car construction and equipment have been so general that few of the engravings of the old book represent the best practice of to-day. The illustrated part of the Dictionary has therefore been recast, and, with the exception of a few pages, is entirely new.

As a rule, plans, elevations and sectional drawings are placed side by side, or directly above and below one another, as if in projection.

The numbers of illustrations in the three editions of the Car Builder's Dictionary issued in 1879, 1884 and 1895 are respectively 811, 2188, 5683. The general arrangement of engravings adopted in the last edition has been retained, the engravings being classified and arranged alphabetically under the following subjects: *Cars, Car-bodies, Car-body details, Car-furnishings, Trucks, Truck-details, Master Car Builder's Standards and Recommended Practice, Hand-cars, Street-cars.*

Considerable new matter has been introduced under the subject of details of separate parts of car-bodies with their forms and dimensions. This includes the details of parts of a box-car, a flat-car, a gondola-car, a four-wheel caboose-car, a baggage-car, and details of several freight and passenger car-trucks. Vestibules have come into use since the issue of the last edition and are therefore a new subject in the Car Builder's Dictionary. The leading types of vestibules in use are shown in general view and by detailed drawings.

In illustrating car-furnishings, a departure is made in the attempt to give to car builders a variety of designs in fittings and furnishings and to that end, several of each type have been given, the number including at least one each of a plain and a decorated style. Street-cars have received much more attention than in the last edition, but no more than the general application of electricity to suburban street-car lines and the the threatening invasion of electric-motor power to some existing steam lines would seem to warrant. The standards and recommended practice of the Master Car Builders' Association have been shown in full and in a group by themselves to facilitate ready reference.

Working-cars have not been illustrated so fully as was desired, because few railroad companies build these cars at the present time, and manufacturers are not willing to give out detailed drawings of their machines and tools, representing, as they do, in many cases, the results of expensive tests and many years of experience, which explains the absence of detailed drawings of certain working-cars.

The number of illustrations of car-springs has been greatly diminished, the practice of carrying a large

variety of springs in stock having been abandoned by the makers. Nowadays most springs are made to order according to specifications, and many of the numerous types existing in 1884 are quite unknown to-day.

The increase in the total number of engravings is due to several causes; somewhat to the increased number of subjects and in a measure to the greater number of types of cars shown, and more especially to the number of illustrations of each kind of car, showing the special features of the present practice of different car-builders. These cars differ in structural details and in the appliances with which they are equipped, as well as in their dimensions, capacities and weights. This was a secondary feature in the earlier editions and it has been greatly enlarged in the 1895 edition, it being the intention to afford numerous designs for comparison and study and from which to select.

The selection being made, the book becomes at once a book of reference between the car builder or purchasing agent and the supply man or manufacturer. Much correspondence and explanation may be avoided by making direct reference to the engravings by their numbers.

While primarily the book is a Dictionary and so called, the past has shown that it has been used and valued for the technical information it contains, quite as much as for the vocabulary of terms. Throughout it will be found that the drawings give the dimensions and structural details and that these drawings, with the details of separate parts given, are sufficient data to enable a car builder or designer to make working drawings of the cars shown. The illustrations comprise in most cases drawings of several types of each kind of car, thus giving to the designer numerous features of construction.

To assist in carrying out this scheme the following arrangement has been adopted: 1, general photographic views of the exterior and interior of cars; 2, general diagram drawings of cars giving general dimensions; 3, drawings of car-bodies, showing structural details; 4, detail drawings of important parts and appliances; 5, the forms and sizes of each separate part or member; 6, car furnishings in various styles and patterns.

In the selection of the subjects for engraving it has been the intention to illustrate only those devices and equipment which are in general use, or are being applied to new equipment, but some things have been inserted for the purpose of definition only. The fact that a certain car or device is illustrated and another is not, cannot be taken as evidence that the Committee or the Editor has made a selection as between those two, or that they believe one is better than some other. Many things have had to be considered in selecting matter for engraving. The completeness of the drawings or photographs furnished, their fitness for engravings, and the success with which the Editor has been able to acquire information, as well as to obtain the drawings themselves, have all contributed to determine which cars or appliances should be illustrated. It should,

however, be stated that the engravings of cars and trucks shown in this edition have been selected from several thousand blue-prints and photographs, collected for the purpose.

To bring the size of the book within reasonable bounds, matter that is merely historical has been omitted. Without a careful survey of the field one can hardly realize the changes which ten years have made in American rolling stock. The sizes, weights and capacity of new cars have been increased by nearly one-half, and corresponding changes have been necessary in almost every structural detail. The kinds of cars have been multiplied and the interchange of traffic greatly augmented. The illustrations, therefore, have been confined, so far as possible, to what are generally considered to be good practice. In making this statement it is only fair to English car-builders to state that the English carriage and goods-wagon shown were illustrated in the last edition, and that no such care has been taken to bring them down to date, as was taken with the American equipment. The same should be said of the vocabulary of terms applicable to the English cars. It is, however, confidently believed that the engravings and the text describing the English equipment fairly represent the present English practice.

The space devoted to definitions and descriptive matter has been increased by about one-fourth. Considerable space has been saved and the duplication of definitions avoided, by embodying several definitions in one, by describing the whole device or appliance and the parts comprising it, and by explaining the use of each part as well as the distinctions which exist between the parts under the name of the device as a whole. The several parts have not then been defined under the name of each separately, but the reader has been referred to the primary definition and to the illustrations.

Everything has been done to facilitate ready reference from the Dictionary to the engravings, and *vice versa*, "since it is obvious that no definition in words of a material object can be so effective and complete as a picture of that object." Drawings of almost every part and detail are given and definitions have been made brief, and, in some cases, omitted entirely where the name of a part in connection with the engraving is alone sufficient to describe the object or part. Alternative names have been given, and when new names have been used, the old one (if such has been in general use) has been retained. The new names adopted have been approved by the Committee appointed by the Master Car Builders' Association.

No doubt mistakes have been made which will come to light. Some minor ones have been discovered by the editor, but they are not sufficient in number or importance to require that certain pages be reprinted or that a table of *errata* be added. They are typographical errors and mistakes in numbering which are apparent at once to the reader, and which, it is believed, will not lead to error. The engravings having been made up and printed before the text was prepared, some of the mistakes made in the illustrated matter have been corrected in the definitions, to which the reader is referred. It is the earnest hope of the editor that no more serious mistakes have been made than have come to his attention.

Much credit is due to the editors of the earlier editions, for it was the great labor undertaken and unflinchingly carried out by them that rendered the completeness and fullness of this revision possible. Few can appreciate the labor and application necessary to bring the Dictionary to its present state, imperfect as it may be; and the editor must confess that his appreciation for the "old book" and for the men who made it has grown with his work on this revision.

NEW YORK, March 1, 1895.

J. C. W.

DIRECTIONS

For Using the Car-builder's Dictionary.

To find the meaning of a given word or term, refer to it in the alphabetical list which constitutes the first half of the book, where a definition similar to those contained in ordinary dictionaries and a reference to some engraving illustrating the object—if it is capable of such illustration—will usually be found.

To find the name of a car or part of a car, examine the alphabetical list of the different classes of engravings in the index which immediately precedes them, until the class is found to which the object looked for belongs, bearing in mind the system of alphabetical classification for the engravings, which is as follows :

CARS, CAR-BODIES, CAR-BODY DETAILS, CAR FURNISHINGS,

TRUCKS AND TRUCK DETAILS, M. C. B. STANDARDS

AND RECOMMENDED PRACTICE, HAND-CARS, STREET-CARS.

By referring to the engravings included in that class a representation of the part or object sought will be found with either its name underneath or a reference number, by which number the name may be learned from the list of names of parts accompanying the illustration and usually to be found in the immediate vicinity.

CLASSIFIED INDEX TO ADVERTISEMENTS.

- Air Brakes :**
Westinghouse Air Brake Co., Pittsburgh, Pa.
- Air Brake Connections :**
Stanley G. Flagg & Co., Philadelphia, Pa.
- Air Brake Hose :**
Boston Belting Co., Boston, Mass.
- Asphalt Paint :**
A. E. Filley Mfg. Co., New York.
- Axles :**
Bass Fdy. & Mach. Wks., Ft. Wayne, Ind.
Baume-Marpent, Haine St. Pierre, Belgium.
Ensign Mfg. Co., Huntington, W. Va.
Gould Coupler Co., New York.
Krupp (Thos. Prosser & Son, New York).
Lima Locomotive & Machine Co., Lima, O.
A. Whitney & Sons, Philadelphia, Pa.
- Basket Racks :**
Adams & Westlake Co., Chicago, Ill.
Dayton Mfg. Co., Dayton, O.
Stewart & Mattson Mfg. Co., Philadelphia, Pa.
- Bell Cord :**
Samson Cordage Works, Boston, Mass.
- Bell Cord Couplings :**
Samson Cordage Works, Boston, Mass.
- Boilers :**
Bass Fdy. & Mach. Wks., Ft. Wayne, Ind.
- Bolsters, Body and Truck :**
Schoen Mfg. Co., Pittsburgh, Pa.
Sterlingworth Railway Supply Co., New York.
- Brake Beams :**
Chicago Railway Equipment Co., Chicago, Ill.
Sterlingworth Railway Supply Co., New York.
- Brake Shoes :**
Lappin Brake Shoe Co., New York.
Ramapo Iron Works, Hillburn, N. Y.
Ramapo Wheel & Fdy. Co., Ramapo, N. Y.
- Brake Slack Adjusters :**
Hinckley Brake Co., Trenton, N. J.
Pratt & Letchworth, Buffalo, N. Y.
Q. & C. Co., Chicago, Ill.
- Brass and Bronze Castings :**
Central Union Brass Co., St. Louis, Mo.
Dayton Mfg. Co., Dayton, O.
Stewart & Mattson Mfg. Co., Philadelphia, Pa.
- Car Replacers :**
Fairbanks, Morse & Co., Chicago, Ill.
- Cars :**
Allison Mfg. Co., Philadelphia, Pa.
Barney & Smith Car Co., Dayton, O.
Baume-Marpent, Haine St. Pierre, Belgium.
J. G. Brill Co., Philadelphia, Pa.
Canda Mfg. Co., New York.
Ensign Mfg. Co., Huntington, W. Va.
Fox Pressed Steel Co., Chicago, Ill.
Jackson & Sharp Co., Wilmington, Del.
Lima Locomotive & Machine Co., Lima, O.
Minerva Car Works, Minerva, O.
Murray, Dougal & Co., Milton, Pa.
Ramapo Iron Works, Hillburn, N. Y.
Russell Wheel & Fdy. Co., Detroit, Mich.
- Cars (Light) :**
Fairbanks, Morse & Co., Chicago, Ill.
Sheffield Car Co., Three Rivers, Mich.
- Contracting Chills :**
Ensign Mfg. Co., Huntington, W. Va.
- Cordage :**
Samson Cordage Works, Boston, Mass.
- Cotters and Keys :**
Standard Tool Co., Cleveland, O.
- Couplers :**
American Coupler Co., Chicago, Ill.
Buckeye Malleable Iron & Coupler Co., Columbus, O.
Chicago Tire & Spring Co., Chicago, Ill.
Gould Coupler Co., New York.
I. G. Johnson & Co., Spuyten Duyvil, N. Y.
McConway & Torley Co., Pittsburgh, Pa.
Michigan Malleable Iron Co., Detroit, Mich.
National Malleable Castings Co., Chicago, Ill.
Pratt & Letchworth, Buffalo, N. Y.
Shickla, Harrison & Howard Iron Co., St. Louis, Mo.
Standard Coupler Co., New York.
Trojan Car Coupler Co., Troy, N. Y.
- Cranes :**
Morgan Engineering Co., Alliance, O.
- Crank-Pin Presses :**
Richard Dudgeon, New York.
Watson & Stillman, New York.
- Door Checks :**
Norton Door Check & Spring Co., Boston, Mass.
- Door Fasteners :**
National Malleable Castings Co., Chicago, Ill.
- Doors, Car :**
Chicago Grain Door Co., Chicago, Ill.
National Malleable Castings Co., Chicago, Ill.
Q. & C. Co., Chicago, Ill.
- Drawbar Attachments :**
Butler Drawbar Attachment Co., Cleveland, O.
- Dust Guards :**
Stier Dust Guard Co., Baltimore, Md.
- Engines, Corliss :**
Bass Fdy. & Mach. Wks., Ft. Wayne, Ind.
- Forgings and Castings :**
Bass Fdy. & Mach. Wks., Ft. Wayne, Ind.
J. H. Bass, Chicago, Ill.
Baume-Marpent, Haine St. Pierre, Belgium.
Ensign Mfg. Co., Huntington, W. Va.
Krupp (Thos. Prosser & Son, New York).
Lenoir Fdy. Co., Lenoir City, Tenn.
Murray Dougal & Co., Wilmington, Del.
Ramapo Iron Works, Hillburn, N. Y.
St. Louis Car Wheel Co., St. Louis, Mo.
- Frogs :**
Ramapo Iron Works, Hillburn, N. Y.
- Furniture :**
A. H. Andrews & Co., Chicago, Ill.
Hale & Kilburn Mfg. Co., Philadelphia, Pa.
Scarritt Co., St. Louis, Mo.
- Gates (for Cars) :**
R. Bliss Mfg. Co., Pawtucket, R. I.
- Hammers, Steam :**
Morgan Engineering Co., Alliance, O.
- Hand and Push Cars :**
Buda Foundry & Mfg. Co., Harvey, Ill.
Fairbanks, Morse & Co., Chicago, Ill.
Sheffield Car Co., Three Rivers, Mich.
- Headlights :**
Adams & Westlake, Chicago, Ill.
Dayton Mfg. Co., Dayton, O.
- Heater Fittings :**
Wm. C. Baker, New York.
Stanley G. Flagg & Co., Philadelphia, Pa.
- Heating :**
Wm. C. Baker, New York.
Consolidated Car Heating Co., Albany, N. Y.
Gold Car Heating Co., New York.
Safety Car Heating & Lighting Co., New York.
- Heating Hose :**
Boston Belting Co., Boston, Mass.
- Hooks :**
Samson Cordage Works, Boston, Mass.
- Hydraulic Machinery :**
Richard Dudgeon, New York.
Morgan Engineering Co., Alliance, O.
Watson & Stillman, New York.
- Insulating Paper :**
Standard Paint Co., New York.
- Jacks :**
Chapman Jack Co., Cleveland, O.
Richard Dudgeon, New York.
Fairbanks, Morse & Co., Chicago, Ill.
Watson & Stillman, New York.
- Journal Bearings :**
Hyatt Roller Bearing Co., New York.
Stewart & Mattson Mfg. Co., Philadelphia, Pa.
- Lamps :**
Adams & Westlake, Chicago, Ill.
Dayton Mfg. Co., Dayton, O.
Jas. L. Howard & Co., Hartford, Conn.
- Lanterns :**
Adams & Westlake, Chicago, Ill.
Dayton Mfg. Co., Dayton, O.
- Lighting :**
Consolidated Car Heating Co., Albany, N. Y.
Safety Car Heating & Lighting Co., New York.
- Locks :**
Adams & Westlake Co., Chicago, Ill.
Dayton Mfg. Co., Dayton, O.
Stewart & Mattson Mfg. Co., Philadelphia, Pa.
- Lock Brackets :**
Chicago Grain Door Co., Chicago, Ill.
- Locomotives :**
Lima Locomotive & Machine Co., Lima, O.
- Locomotive Boiler Tubes :**
Allison Mfg. Co., Philadelphia, Pa.
- Malleable Iron :**
Buckeye Malleable Iron & Coupler Co., Columbus, O.
Dayton Malleable Iron Co., Dayton, O.
Stanley G. Flagg & Co., Philadelphia, Pa.
Gould Coupler Co., New York.
Michigan Malleable Iron Co., Detroit, Mich.
National Malleable Castings Co., Chicago, Ill.
Pratt & Letchworth, Buffalo, N. Y.
- Motor Trucks, Electric :**
J. G. Brill Co., Philadelphia, Pa.
Canda Mfg. Co., New York.
Peckham Motor Truck & Wheel Co., New York.
- Packing :**
Boston Belting Co., Boston, Mass.
Ramapo Wheel & Fdy. Co., Ramapo, N. Y.
- Paint :**
Buckeye Paint & Varnish Co., Toledo, O.
Detroit Graphite Mfg. Co., Detroit, Mich.
F. W. De Voe & Co., New York.
National Paint Wks., Williamsport, N. Y.
Standard Paint Co., New York.
- Pipe, Iron and Steel :**
Allison Mfg. Co., Philadelphia, Pa.
Stanley G. Flagg & Co., Philadelphia, Pa.
- Pipe Fittings :**
Allison Mfg. Co., Philadelphia, Pa.
Stanley G. Flagg & Co., Philadelphia, Pa.
- Platforms and Buffers :**
Gould Coupler Co., New York.
Isaac G. Johnson & Co., Spuyten Duyvil, N. Y.
McConway & Torley Co., Pittsburgh, Pa.
- Platform Railings :**
Dayton Mfg. Co., Dayton, O.
- Plushes :**
Jas. L. Howard & Co., Hartford, Conn.
Sanford Mills, Boston, Mass.
- Pressed Steel :**
Fox Solid Pressed Steel Co., Chicago, Ill.
Schoen Mfg. Co., Pittsburgh, Pa.
- Punches :**
Richard Dudgeon, New York.
Morgan Engineering Co., New York.
- Rail Benders :**
Watson & Stillman, New York.
- Railroad Castings :**
Bass Fdy. & Mach. Wks., Ft. Wayne, Ind.
J. H. Bass, Chicago, Ill.
Dayton Malleable Iron Co., Dayton, O.
Lenoir Fdy. Co., Lenoir City, Tenn.
Lima Locomotive & Machine Co., Lima, O.
Murray, Dougal & Co., Milton, Pa.
Ramapo Iron Works, Hillburn, N. Y.
St. Louis Car Wheel Co., St. Louis, Mo.
A. Whitney & Sons, Philadelphia, Pa.
- Riveting Machines :**
Morgan Engineering Co., Alliance, O.
- Roofing :**
Drake & Wiers Co., Cleveland, O.
Ensign Mfg. Co., Huntington, W. Va.
Excelsior Car Roof Co., St. Louis, Mo.
A. E. Filley Mfg. Co., New York.
C. B. Hutchins & Sons, Detroit, Mich.
Paige Car Wheel Co., Cleveland, O.
Standard Paint Co., New York.

Rubber Goods, Mechanical :

Boston Belting Co., Boston, Mass.

Sash Cord :

Samson Cordage Works, Boston, Mass.

Seats :

Hale & Kilburn Mfg. Co., Philadelphia, Pa.
Hartford Woven Wire Mattress Co., Hartford, Conn.
Scarritt Co., St. Louis, Mo.

Side-Body Truss :

John Rhoads & Son, West Philadelphia, Pa.

Signal Cord :

Samson Cordage Works, Boston, Mass.

Spring :

Chicago Tire & Spring Co., Chicago, Ill.
A. French Spring Co., Pittsburgh, Pa.

Snow Plows :

Ensign Mfg. Co., Huntington, W. Va.

Standpipes :

Fairbanks, Morse & Co., Chicago, Ill.
Sheffield Car Co., Three Rivers, Mich.

Steel Castings :

Chester Steel Castings Co., Chester, Pa.
Stanley G. Flagg & Co., Philadelphia, Pa.
Gould Coupler Co., New York.
I. G. Johnson & Co., Spuyten Duyvil, N. Y.
Krupp (Thos. Prosser & Son, New York).
Lima Locomotive & Machine Co., Lima, O.
Pratt & Letchworth, Buffalo, N. Y.
Shickle, Harrison & Howard Iron Co., St. Louis, Mo.
Taylor Iron & Steel Co., High Bridge, N. J.

Step Benders :

Dayton Mfg. Co., Dayton, O.

Supplies :

Adams & Westlake, Chicago, Ill.
Buda Foundry & Mfg. Co., Harvey, Ill.
Central Union Brass Co., St. Louis, Mo.
Dayton Mfg. Co., Dayton, O.

Supplies (Continued) :

Fairbanks, Morse & Co., Chicago, Ill.
Jas. L. Howard & Co., Hartford, Conn.
Q. & C. Co., Chicago, Ill.
Stewart & Mattson Mfg. Co., Philadelphia, Pa.

Switches :

Baume-Marpent, Haine St. Pierre, Belgium.
Ramapo Iron Works, Hillburn, N. Y.

Switch Stands :

Buda Foundry & Mfg. Co., Harvey, Ill.
Ramapo Iron Works, Hillburn, N. Y.

Tires :

Chicago Tire & Spring Co., Chicago, Ill.
Krupp (Thos. Prosser & Son, New York).
Standard Steel Works, Philadelphia, Pa.

Tools :

Berry & Orton Co., Philadelphia, Pa.
J. A. Fay & Egan Co., Cincinnati, O.
Standard Tool Co., Cleveland, O.

Trimnings :

Adams & Westlake Co., Chicago, Ill.
Central Union Brass Co., St. Louis, Mo.
Dayton Mfg. Co., Dayton, O.
Jas. L. Howard & Co., Hartford, Conn.
Stewart & Mattson Mfg. Co., Philadelphia, Pa.

Trolley Cord :

Samson Cordage Works, Boston, Mass.

Truck Channels :

Schoen Mfg. Co., Pittsburgh, Pa.

Trucks, Freight Car :

Fox Solid Pressed Steel Co., Chicago, Ill.

Turnbuckles :

Cleveland City Forge & Iron Co., Cleveland, O.

Varnishes :

Buckeye Paint & Varnish Co., Toledo, O.
F. W. De Voe & Co., New York.
Pratt & Lambert, New York.

Ventilators :

Car Ventilator Co., Philadelphia, Pa.
Q. & C. Co., Chicago, Ill.

Vestibules :

Gould Coupler Co., New York.
I. G. Johnson & Co., Spuyten Duyvil, N. Y.

Water Closets :

Adams & Westlake Co., Chicago, Ill.
Dayton Mfg. Co., Dayton, O.
Jas. L. Howard & Co., Hartford, Conn.

Weather Strips :

D. W. Bosley Co., Chicago, Ill.

Wheel Grinding Machines :

Ensign Mfg. Co., Huntington, W. Va.

Wheel Presses :

Watson & Stillman, New York.

Wheels :

Base Fdy. & Mach. Wks., Ft. Wayne, Ind.
J. H. Bass, Chicago, Ill.
Canda Mfg. Co., New York.
Ensign Mfg. Co., Huntington, W. Va.
Krupp (Thos. Prosser & Son, New York).
Lenoir Fdy. Co., Lenoir City, Tenn.
Lima Locomotive & Machine Co., Lima, O.
Ramapo Wheel Co., Cleveland, O.
Ramapo Wheel & Fdy. Co., Ramapo, N. Y.
Russel Wheel & Fdy. Co., Detroit, Mich.
Standard Steel Works, Philadelphia, Pa.
St. Louis Car Wheel Co., St. Louis, Mo.
Taylor Iron & Steel Co., High Bridge, N. J.
Washburn Car Wheel Co., Hartford, Conn.
A. Whitney & Sons, Philadelphia, Pa.

Window Shades :

Adams & Westlake Co., Chicago, Ill.
E. T. Burrowes Co., Portland, Me.

Woodworking Machinery :

Berry & Orton Co., Philadelphia, Pa.
J. A. Fay & Egan Co., Cincinnati, O.

A DICTIONARY OF TERMS

USED IN

CAR-BUILDING.

A

"A" car-roof. A car-roof with straight carlines, meeting at a point like rafters in the center of the upper deck. (Rarely met in standard construction.)

Acme automatic-window-shade. Fig. 4550. A car shade with a shade-holding device, which consists of a hollow tube with a metallic guide at either end, through which two cords are passed, one end of each being fastened to the casing on either side of the shade near the top, the cords passing down the side to the bottom of the shade, thence through the tube and down the other side to the bottom, being fastened at the bottom of the window to the casing.

Acme-burner. Figs. 3265-8, etc. A burner constructed upon nearly the same principle as a locomotive *headlight burner*, figs. 3388-9, and which gives a powerful light.

Acme-lamp. A lamp fitted with an *Acme burner*.

Acme spring. A form of elliptic spring, the peculiarity of which consists in tapering a single leaf from the center toward the ends, without the use of a number of separate leaves. An improved type is constructed of plates with a beveled edge, arranged one above the other as usual, and held in position by a wrought-iron band.

Acorn. Fig. 3784. A general term for the ornaments of tips resembling the acorn, used to finish the ends of rods of various forms.

Acorn butt-hinge. Figs. 2586 and 2591-2. A trade term for hinges having the hinge-pin ornamented with acorns at each end.

Adams journal-box. Figs. 5146-51. One of several, for collarless journals using a stop-wedge with a brass bearing against the end of the axle. It has a collar shrunk on to the axle that covers over the round flange on the back of box to exclude the dust. The details are fully shown in the figures.

Adjustable bracket-lamps. Figs. 3300, 3304.

Adjustable foot-rest. 1. Figs. 3924-5 and 3974-5. A sliding foot-seat, supported by various mechanical devices—as by a ratchet-arc or on rabbit-pieces. 2. Figs. 3971-3. A foot-rest or rail under a seat which can be adjusted to suit the passenger using it. See *Foot-rest*.

Adjustable Lamp-canopy. 13, figs. 3292-3 and 3449.

Adjusting-lever (Hartley chair). 15, figs. 3998-9. A lever by which the position of the adjustable foot-rests and back is regulated.

Adjustable Shade-holder. Fig. 3303. See also figs. 3435 and 3437.

Advertising-rack rail. 180, figs. 5654-8. A rail to which the frames for advertising cards are screwed or otherwise fastened.

Air-brake. Any brake operated by air pressure, but usually restricted to systems of continuous brakes operated by *compressed air*, in distinction from *vacuum brakes*, which see, which are operated by creating a vacuum. The air is compressed by some form of pump on the locomotive; and is conveyed by pipes and flexible hose between the cars, to cylinders and pistons under each car, by which the pressure is transmitted to the brake levers, and thence to the brake-shoes. This system is what is now termed the *Plain Air-brake* or *Straight Air-brake*. This brake is now obsolete, having been replaced

AIR

by the Automatic Air-brake, which see, and also see *Westinghouse Air-brake, Quick-action Automatic, Eames vacuum brake, Ganet Air-brake, New York Air-brake*.

Air-brakes—general arrangement and details. Figs. 5433-4, etc. The general arrangement and details of brake gear for air-brake cars, as shown, are standard. The following standards have also been adopted in this connection: 1. Maximum train-pipe pressure, 70 pounds per square inch. 2. Maximum brake power in freight cars, 70 per cent. of the light weight of car. 3. All levers 1 inch in thickness; all pins turned to 13-32 inches in diameter; all jaws or clevises made of $\frac{1}{4}$ -inch by $2\frac{1}{4}$ -inch iron; all rods $\frac{1}{2}$ inch diameter. 4. Angle of brakebeam lever, 40 degrees with vertical.

Air-brake cut-out-and-defect card. (M. C. B. recommended practice). Figs. 5577-8. See *Air-brake repair card*.

Air-brake hose. See *Brake-hose*.

Air-brake repair card. In 1894 a recommended practice was adopted to use an air-brake repair card, as shown, figs. 5577-8, to report to division terminals such defects as are found by trainmen which require brake to be cut out.

Air-chamber (of student lamp). H, fig. 3399.

Air-cylinder oil-cup (air-pump). 46, fig. 1689; 98, figs. 1691-2.

Air-flue (refrigerator cars). Figs. 274-286. The vertical passage of the car through which the chilled air passes to enter the refrigerator.

Air-gage (air-brake). See 20, figs. 1699-1705 and 1718. A gage to register the pressure of air in the reservoir, similar to an ordinary steam-pressure gage.

Air-inlet. An opening for the admission of air to an air-compressor or a refrigerator car. The term includes both the *air-strainer* and *air-pipe*.

Air-pipe. (air-brake). 8, fig. 1699. More properly *supply-pipe* or *air-inlet*. The *train brake-pipe* is sometimes called the air-pipe.

Air-pipe strainer. (air-brake). 5, fig. 1699; 6, fig. 1695-7. Also called *inlet-strainer*, which see. It is frequently a part of the *Drain-cup*, which see. Figs. 1745 and 1758-60.

Air-piston. (air-brake). See 11, figs. 1689; 66, fig. 1691, and 31-32, fig. 1752. See *Piston*. The air-pistons and steam-pistons of engines and air-pumps are generally alike in style of construction.

Air-piston packing-rings. (air-pump). 13, fig. 1689. See *Air-piston*.

Air-pump and engine complete. (air-brake). See *Engine and air-pump*. Figs. 1689-92, 1699, and 1752.

Air-pump Cylinder (air-brake). See 4, fig. 1699; 5, 1689 and 1690-2 and 1752. A hollow cast-iron cylinder with a piston, which piston compresses the air required to operate the brakes. The piston in the air-cylinder is directly connected with and is worked by the piston in the *steam-cylinder*.

Air-pump Cylinder-head (air-brake). 6, figs. 1689; 64, 1691-2. The cover for the lower end of the air-cylinder of an air-pump for an air-brake. See *Cylinder-head*.

Air-pump Governor. See *Governor*.

Air-signal reducing valve. See *Reducing valve*.

Air-strainer 1. (air-pump). 106, figs. 1691-2; 16, figs.

1706-7. A funnel-shaped mouthpiece on the end of the air-inlet pipe, with a perforated plate over its mouth to exclude dirt, insects, etc.

2. (train brake pipe). 6, figs. 1693-8; fig. 1746. An air-strainer and drain-cup, the purpose of which is to strain out particles of dust, scale, etc., and to drain moisture from the pipes.

Air-valve, seat and cage. (air-pump). 86, 87, 88, figs. 1691-2.

Air-valve chamber cap. (air-pump). 89, figs. 1691-2.

Aisle. Figs. 423, 467, 482, and 488. The longitudinal passageway through a passenger car, between the seats.

Aisle seat-end. 123, figs. 447 and 541; 3, figs. 3917-3981. The end or arm of a transverse car-seat next the aisle. See also *Wall seat-end*.

Aladdin lamp-burner. Figs. 3378 and 3382. One of the no-chimney burners for mineral oil, used in Signal-lamps.

Alarm-gong hammer and button (Street cars). 200, 201, figs. 5654-8.

Alcove. Figs. 3552-3. A recess. See *Faucet-alcove*. *Lamp-alcove*. *Water-alcove*.

Alcove-faucet. Figs. 3552-3. A faucet in a water-alcove connected with a water-cooler to supply drinking-water. See *Faucet*.

Alcove-front. See *Water-alcove front*.

Alcove-lamp. A lamp placed in a recess in the side of a car. Also called *Panel-lamp*, as it is usually covered by a panel.

Alcove-pan or bottom. See *Water alcove-pan* or *Bottom*.

Aldrich brake-wheel. Fig. 16.

Allen paper-wheel. Figs. 5255-73. A car wheel with a steel tire, a cast-iron hub or center, and the space between the tire and center filled with compressed paper and held in place by wrought iron face plates on either side extending from the center to the tire and bolted thereto. See *Steel-tired wheel*.

Alleyway. Figs. 186-7 and 204. More properly a *corridor*. A narrow passage at the side of staterooms or compartments in parlor or sleeping cars. In Mann boudoir cars it runs the entire length of the car, fig. 205.

American Brake Company's brake-gear. Fig. 1749. The company makes several types of Brake-gear and connections, not illustrated.

American car-coupler. Figs. 2075-81.

American (continuous) draft and buffing apparatus. Figs. 1940-58. An apparatus by which the draw-bars at both ends of the car are connected by two rods with loops at the ends, that hook over the ends of a bar passing through the shank of each draw-bar. It has two *buffer-springs* and two follower-plates, at each end of the car.

American dust-guard. Figs. 5159-60. A dust-guard in two pieces, which are held together and against the axle by a spring.

American flush-car-door. Figs. 1823-6 and 1812 49. A car-door which when closed is flush with the sheathing or siding of the car. This is effected by curving the track of the door so that when it is closed the front side is forced in, and the rear is then forced in by a lever, the *lower sheave* being hinged so as to permit the lateral movement.

American refrigerator-car. One of the class of cars having the iceboxes at both ends of the car supplied from the roof. The drip-water passes off through troughs, and is utilized for cooling as it passes away. See *Refrigerator-car*.

American steel-truck-bolster. Figs. 4790-1. A truck-bolster made in one piece of cast steel. It embodies several ordinary pieces in one, viz., the truck-bolster, the center-plate and bolts, four bolster-guide blocks and bolts, two truck side-bearings and bolts, two spring-plates, etc. It was mentioned with favor by the M. C. B. Committee on Freight Trucks, 1894.

American student-lamp. Figs. 3398-9 and 3268. See *Argand-lamp*. *Student-lamp*.

Angle-clips (Janney freight coupler). 113, figs. 2161-82. Plates to fit the angles or bands of an *uncoupling rod*. It is fastened by *Angle-clip bolt*, 114.

Angle-cock. (air-brakes). 25, figs. 1693-8, fig. 1745.

Angle-cock (Consolidated car heating). Fig. 2983. An angle-valve for controlling inflow of steam to the heating apparatus.

Angle drip-valve (Safety's Heating System). 603b, figs. 3031-4. See *Direct steam heating*.

Angle-iron. A general term applied by makers to iron rolled in the form of an L, but with the corner rounded off somewhat. When the angle is rolled to a sharp corner and not rounded off, it is termed *square-root iron*.

Angle-plate or footing (Barr vestibule). 13, figs. 2425-28. An offset footing of the *face-plate* of the *Barr wing vestibule* which carries the weight of it to the platform proper. In consequence of its being an offset the *face-plate* tends to lean out against the opposing plate of another car to which it is coupled.

Anti-clinker car-heater. Figs. 3058-60. See *Spear anti-clinker car-heater*.

Anti-clinker grate. 18, fig. 3059. A stove-grate placed below the fire-pot so as to leave an annular opening between the two through which the clinkers can be raked out from the fire.

Anti-friction car-door hanger. Figs. 2830 and 2834. See *Car-door hanger*.

Anti-telescoping device. Figs. 514-18. A type of end-framing, adopted by the Pullman's Palace Car Company, in which the end-sill is greatly strengthened by an *end-sill stiffening plate*, an *end-sill stiffening angle-bar*, *corner-angle-posts*, and *end-plate strengthening angles*, *knee-irons*, etc., as shown in the engravings. The device is known as the "Sessions" anti-telescoping device and the patents are owned by the Pullman's Palace Car Company.

Anvil (of track torpedoes). Fig. 3724. Interior pieces of iron placed directly over the fulminating powder to insure its ignition. Some track torpedoes have three anvils.

Apron. See *Door-apron*. *Roof-apron*. *Bunk-apron*.

Arbel wheel. Figs. 5274-81. In this country, strictly, a wheel with a wrought-iron *center*, *plate* or *spokes*, and a steel tire manufactured by the Arbel establishments, Rive de Gier, France. The wheels as built at the Arbel shops are built up of loose parts and then heated and forged solid under a steam-hammer. The so called *Arbel wheels*, of which there are a large number in use in this country (see *Car-wheel*), are not from the Arbel establishments of France, but are from the Société Cockerill, Belgium, and were introduced by Chas. G. Eckstein & Co., of New York. The centers of these wheels as shown in figs. 5274-81 are forged in much the same manner as at the Arbel establishments, the tire being fastened by the *Gibson retaining ring*. This wheel is distinguished by the name of the *Arbel-Cockerill*, or *Cockerill-Arbel wheel*. The Arbel establishments now have an office in the Havemeyer Building, New York City.

Arbor. "A spindle or axle for a wheel or pinion; a mandrel on which a ring or wheel is turned in a lathe."—*Knight*. See *Door-latch arbor*.

Arch. See *Truss-arch*.

Arch (of an elliptic spring). Fig. 5230. The height from the center of the *scrolls* at the ends of the elliptics to the under side of the main leaf of the spring. *Twice* the *arch* of an elliptic spring, less the thickness of the *spring-bands*, is the *set* and is the maximum amount which an elliptic spring can be compressed. In a *half-elliptic* spring the arch and set differ only in the thickness of the *spring-band*.

Arch-bar. Figs. 4587-90. 14, figs. 4580-4805. A bent wrought-iron or steel bar which forms the top member of an iron truck side-frame. In the *Diamond truck* the next lower member is the *inverted arch-bar*, and the next lower (occasionally used) is the *auxiliary arch-bar*, 16, fig. 4750. The *tie-bar* comes under all, and sometimes becomes an arch-bar. See also *Center-bearing arch-bar* and *Center-bearing inverted arch-bar*, for 6-wheel trucks.

Arch-rail (English). See *End arch-rail*.

Arched roof. Figs. 95-6. A roof, the surface of which is curved. Some boudoir and private cars are built with arched roofs; they are at the present time little used for passenger-cars. A *Turtle-back roof*.

Argand burners. Figs. 3371-2. See *Lamp-burners* and below.

Argand-lamp. A lamp invented by Argand, a native of Geneva, about the year 1784. The burner consists of two concentric cylindrical tubes in which is the annular wick. The tube inclosing the wick is closed at the bottom and communicates by a pipe with the oil reservoir. The interior tube being open, free access of air is allowed to the interior and exterior of the flame, insuring more perfect and equal combustion. In 1880 a French mechanic named Carcel patented an improvement by which the oil is pumped from the reservoir to the wick by the power derived from a spring or by the ascending column of air above the chimney. This is called the *Mechanical Lamp*, but is little used except in large lamps for light-houses.

Argand-lamp (Moehring). Patented May 18, 1875. This lamp has certain improvements in the way of convenience for filling and for the use of a long wick.

Arm. See *Berth-arm.* *Seat-back arm.*
Lamp-arm. *Striker-arm.*
Seat-arm. *Top-arm.*

Arm-cap. Figs. 4017-21. A metal plate, wooden-cap, or piece of upholstery with which the top of a seat-end, arm-rest, or chair-arm is covered. Those for chair-arms, however, are also called *chair-arm plates*, which see. An *arm-rest*, which see, is fixed to the side of the car.

Arm-holder (English). 200, fig. 501. See *Arm-sling*.

Armored brake-hose. Figs. 1668 a-b-c. Brake-hose covered with a woven wire fabric, to protect it from injury or abrasion. Another form of armored brake-hose is formed by winding a continuous wire spirally around it by a machine which makes the spiral slightly smaller than the tube, so that it grips it tightly. *Vacuum brake-hose*, for vacuum brakes, is usually lined with coiled wires on the inside to prevent collapsing, but such is not termed armored brake-hose.

Arm-pivot. See *Seat-arm pivot*.

Arm-plate. See *Seat-arm plate*.

Arm-rest. A wooden or metal bar or ledge attached to the side of a car, and not, like an *arm-cap*, to the top of a seat end, for passengers to rest their arms on.

Arm-rest bracket. See *Arm-rest*. A bracket supporting the arm-rest.

Arm-sling (English). 200, fig. 501. In a carriage, a padded ornamental leather strap, looped and secured to the *doorway pillar*. Also called *arm-holder* or *arm-strap*.

Asbestos cock (Consolidated Car Heating). Fig. 2921. A cock packed with asbestos with a drip connection, which drains the opening when the cock is shut off. This allows the leakage to escape to the ground and avoids a freeze in the train-pipe in cold weather.

Asbestos felt. A preparation of asbestos in loose sheets similar to felt, for use as a non-conductor. It is largely used in refrigerator-cars. It is manufactured for that purpose in rolls about 42 in. wide, and weighs about 1 lb. per square yard. It must be handled with care to prevent tearing.

Ascending-rail (English). 175, figs. 501, 504. Nearest American equivalent, *grab-iron* or *hand-rail*. The end

ascending-rail is a long wrought-iron bar secured at the ends of a covered vehicle, serving as a hand-rail for ascending to the roof. The *roof ascending-rail*, or *roof commode handle*, 176, is a similar hand-rail at the end of the roof of a covered vehicle.

Ascending-step (English). 174, figs. 501, 504. Nearest American equivalent, *ladder-round*. A roughed wrought-iron plate secured to the ends of a covered vehicle serving as a step to ascend to the roof. They are used in England on both passenger and freight cars. In America, only on freight and electric motor cars.

Ash-pan (Baker heater). Fig. 2872.

Ash-pit. Figs. 2875, 2890, and 3070. The lower portion of every stove, under the *grate*, into which the ashes fall. Under it is sometimes placed an *ashbox*, fig. 2872. The ash-pit is made up of a casting usually called the *ash-pit base* and closed by an *ash-pit front* carrying one, or more commonly two, *ash-pit doors*. An *ash-pit ring* serves as a hopper to guide the coal and ashes on to the grate. The doors are distinguished as right and left; as for a person standing facing the stove. The ash pit doors are sometimes carried as in fig. 2865, in an *ash-pit frame* instead of an *ash-pit front*. Below are references to a few of the many such parts.

Ash-pit (Baker heater). Fig. 2875.

Ash-pit door (Baker heater). Figs. 2871, 2892, and 3066.

Astral Argand-burner. Fig. 3372. See *Argand-lamp*.

Atmospheric brake. See below, also *Air brake*. *Vacuum brake*.

Attachment of couplers to cars. Figs. 5506-37. See *Drawbar attachments*, etc.

Attock's body-block (English). 186, figs. 502-3. Attachment of Coupler. See *India-rubber body-cushion*.

Automatic air-brake. One which is automatically applied by breakage of a coupling, derailment, etc. The term is indefinite, but usually refers to the *Westinghouse automatic air-brake*, figs. 1688-1748, which see, which is the one in most general use in this country.

Automatic closet-ventilator. Figs. 3341-2. See *Bell's exhaust hopper-ventilator*.

Automatic freight-car coupler. Figs. 2073-2276. A coupler which will couple by impact without the necessity of a person going between the cars. The Master Car Builders' coupler is any coupler of the vertical-plane type which conforms to certain contour lines adopted by the M. C. B. Association. This coupler is shown in figs. 5502-5, the contour lines in figs. 5499-5501. Recommended practice in attaching couplers, 5506-11.

This form of automatic coupler was adopted as standard in 1887 (see report for that year, pages 199-208, 243 and 253). Further details were adopted in 1889 and 1893. An action of the Association in 1889 permits the use of a coupler 28 ins. long instead of 30 ins. as shown, for use only on cars already in service and requiring such length drawbar. The carrier iron as shown for this coupler adopted in 1889.

The standard contour line shown was announced by Executive Committee under instructions from the Association, April 8, 1888. The limit gages for preserving standard contour line adopted in 1891.

These gages, properly proven by master gages, may be procured from Pratt & Whitney Company, of Hartford, Conn. A duplicate set of master gages is held in the office of the Secretary for reference when desired.

Other types of couplers are shown as follows:

<i>American</i> , figs. 2075-81.	<i>Johnston</i> , figs. 2183-89.
<i>Brown's emergency</i> , figs. 2082-7.	<i>Link and pin</i> , figs. 2073-4.
<i>Buckeye</i> , figs. 2088-98.	<i>Pooley</i> , figs. 2191-98.
<i>California</i> , figs. 2104-11.	<i>Smillie</i> , figs. 2199-2201.
<i>Chicago</i> , figs. 2111 a b c.	<i>Standard</i> , figs. 2202-8,
<i>Drexel</i> , 2112-24, figs. 2244-45.	2256-66.
<i>Elliott</i> , figs. 2125-40.	<i>Thurmond-McKeen</i> , figs.
<i>Gould</i> , figs. 2141-47, 2246-51.	2209-22, 2277-81.
<i>Hinson</i> , figs. 2150-60.	<i>Trojan</i> , figs. 2223-39,
<i>Janney</i> , figs. 2161-82, 2252.	2267-74.
	<i>Van Dorsten</i> , figs. 2240-43, 2275 6.

Except the *Link and Pin*, these are all of the so-called "vertical plane," type. The movements of their parts in

coupling take place in a horizontal plane, and bear a close resemblance to the original Janney passenger coupler.

Automatic lubricator. A device for feeding at regular intervals a certain quantity of oil or lubricant to a cylinder or some mechanism requiring lubrication.

Automatic ventilator. Figs. 4299-4329. A ventilator which is self-adjusting, so as to exhaust air from a car if the train runs in either direction. A great variety of such devices exists, not all shown. See *Ventilator. Bell's exhaust hopper-ventilator.*

Automatic window-catch. A device to hold a window sash from being shoved up or down. See *Sash-lock.*

Auxiliary arch-bar. 16, fig. 4750. A wrought-iron bar sometimes used, which forms the lower member of diamond-truck side-frame. In some cases such arch-bars are made *continuous* by transverse pieces which extend across from one frame to the other under the transoms. See *Arch-bar.*

Auxiliary brake-equalizing-lever. 7, fig. 1540-2. (Six wheeled truck.) A short lever to which the brake-lever connecting-rod is fastened and which divides the pressure equally between the center pair of wheels and the outside pair of wheels.

Auxiliary buffer-spring. A spring placed back of a draw spring to give greater resistance to compression on the drawbar in buffing. In this manner two springs operate in buffing, and only one in tension.

Auxiliary draft-spring. A spring of low capacity and limited motion, placed back of the rear follower to compensate for absence of slack.

Auxiliary drawbar follower-plates. Iron plates which bear against the ends of an *auxiliary buffer-spring*. One plate of this kind bears against each end. The pressure on the drawbar is thus transmitted to the auxiliary spring.

Auxiliary draw-spring. (English). 52, fig. 503. An India-rubber spring on the drawbar which assists in taking the draft strain. Seldom used.

Auxiliary reservoir. (Westinghouse automatic air-brake). Fig. 1688; 1, figs. 1693-4 and figs. 1734-6. A cylindrical reservoir made of boiler iron, attached to the under side of a car or tender by *auxiliary-reservoir bands* attached through *auxiliary-reservoir beams*. In freight cars, auxiliary-reservoir beams are termed *brake-cylinder blocks* and *end-blocks*. The reservoir serves to hold a supply of compressed air to operate the brakes of each car, and is supplied from the *main reservoir* on the engine through the train-pipe. For freight service, the auxiliary reservoir, triple-valve and brake-cylinder are combined in one piece, figs. 1738-9 and 1, figs. 1695-8.

Auxiliary reservoir-bands. (air-brake). 17, figs. 1693-8. See above.

Auxiliary reservoir-beams. (air-brake). Short wooden timbers bolted to the under side of the sills. In freight cars called *brake-cylinder blocks*. See above, and shown in figs. 1693-8.

Auxiliary-reservoir bleeding-cock. 18, figs. 1693-8.

Auxiliary reservoir-nipple. (Automatic air-brake). 21, figs. 1693-4. A short pipe by which the triple-valve is connected with the auxiliary reservoir.

Auxiliary rubber bearing-spring. (English). 87, fig. 501. An electric washer interposed between the adjusting screw nut and the scroll-iron. Not in general use.

Axle. 2, figs. 4580-4966; figs. 1974-5, etc. A shaft made of wrought iron or steel to which a pair of wheels is attached. They are distinguished according to use, as *passenger-car, freight-car, hand-car, street-car axle*, etc., and according to mode of manufacture as *hammered, foggoted, muck-bar axles*, etc., which see. See also *Car-axle*. In nearly all cases the wheels are both rigidly fastened to the axle, but it has been attempted to make one, or both of them loose, so that they can turn independ-

ently of the axle. Experience, however, has discounted all these attempts and indicated that the gain is far less and the loss greater than had been supposed. The M. C. B. standard axle is shown in figs. 5419-21. The following are the names of the parts: 1, *Center of axle*; 2, *Neck of axle*; 3, *Wheel-seat*; 4, *Dust-guard bearing*; 5, *Collar*; 6, *Journal*. See *Hammered car-axle*.

Axle (M. C. B. Standard). 1. With journals $3\frac{1}{4}$ by 7 inches. Fig. 5419. This axle is the standard of the Association for cars of 40,000 pounds capacity. In 1873 a standard for car axle was recommended, the form and dimensions of which, excepting the diameter in the middle, were substantially the same as shown in this figure. In 1884 the diameter at the middle was increased from $3\frac{3}{4}$ inches to $4\frac{1}{4}$ inches, by letter ballot. 2. With journals $4\frac{1}{4}$ by 8 inches. This axle was adopted as a standard of the Association for cars of 60,000 pounds capacity, by letter ballot, in 1889.

Axles (M. C. B. Rules for interchange of traffic.) The defects in axles for which cars may be rejected are as follows:

(n) Axles bent or broken.

(o) Journals cut.

(p) Axles less than the following limits:

Capacity of Car.	Journal.	Wheel-Seat.	Center.
60,000	$3\frac{3}{4}$ in.	5 in.	$4\frac{1}{8}$ in.
50,000	$3\frac{1}{2}$ "	$4\frac{3}{4}$ "	$4\frac{1}{8}$ "
40,000	$3\frac{1}{4}$ "	$4\frac{5}{8}$ "	$3\frac{7}{8}$ "
33,000	3 "	$4\frac{1}{4}$ "	$3\frac{1}{2}$ "
20,000	$2\frac{3}{4}$ "	$4\frac{1}{4}$ "	$3\frac{1}{8}$ "

Axle-box. (English). A *Journal-box*, which see. See *Grease axle-box. Oil axle-box.*

Axle-box cover. (English). 36, figs. 348-51 and 503. A hinged movable cover on the axle-box through which the lubricant is introduced. On English oil axle-boxes the cover is generally bolted to the box, with a strip of leather interposed to make an oil-tight joint. The oil is replenished monthly through a small orifice closed by a screw-plug, or spring-hinge.

Axle-box keep. (English). 37, figs. 348-51 and 503. The lower part of an axle-box, which in an oil-box contains the lubricant, and in a grease-box simply protects the under side of the journal from dust.

Axle-collar. Figs. 5419-20 and 5149. A rim or enlargement on the end of a car-axle, which takes the end thrust of the journal-bearing. Sometimes called a *button*.

Axle-gages. Gages for fixing the lengths and diameters of an axle. Were at one time standards of M. C. B. Association.

Axle-guard. 1. (English.) 14, figs. 501-4. American equivalent, *pedestal*. The ordinary or W pattern consists of a wrought-iron plate attached to the *solebar*, which permits vertical motion of the axle-box, but restrains movement in any other direction. 2. Axle-guard has of late been applied to the *axle safety-strap* as at Figs. 5070-3. It has also been applied to the *safety-beam*.

Axle-guard crown. (English). 17, figs. 348-51. The main part of the *axle-guard*, which see.

Axle-guard crown washer. (English). 20, figs. 348-51. A piece of wrought-iron plate, used as a washer for three or more bolts, which secure the main part of the *axle-guard* to the *solebar*.

Axle-guard keep, or horn-stay. (English). 21, figs. 348-51 and 501-4. A piece of iron which secures the lower end of the jaws of the *axle-guards* together.

Axle-guard stay-rod, or axle-guard stretcher. (English). 15, fig. 501. American equivalent, *pedestal tie-bar*. A longitudinal rod connecting the lower ends of the *axle-guards*, and keeping them at the right distance apart.

Axle-guard strap. See *Axle safety-strap*.

Axle-guard truss. Figs. 5127-9. 60, figs. 4963-6. A wrought iron forged bar connecting the iron transoms of a six-wheeled truck, and carrying the *middle safety-beam*. It were better called the *middle safety-beam truss*.

Axle-guard wing (English). 18, figs. 348-51. The inclined part of an *axle-guard*, strengthening it fore and aft.

Axle-guard wing-washer (English). 19, figs. 348-51. A piece of plate used as a washer for two or more bolts securing the wing of the *axle-guard* to the *solebar*. See *Axle-guard wing*.

Axle-packing. A *dust-guard*, which see. The *journal-packing* is often called *axle-packing*.

Axle safety-bearing. (passenger-car trucks). 54, figs. 4813 and 4842. A bar of iron like an inverted letter U, or a block of wood bolted to the safety-beam of a truck above the axle. The *axle safety-strap*, 55, goes below it, the two parts together forming a circle around the axle. The *axle safety-bearing thimbles*, 56, are used as distance-pieces to hold both in their proper position. The details of the form of all these parts have some little variation, as will be seen from the illustrations, figs. 4806-4966.

Axle safety-bearing thimbles. 56, figs. 4806-4966, figs. 4876-7. See above.

Axle safety-strap. 55, figs. 4942-4963. See above.

Axle-seat. The hole in a car-wheel which receives the axle. More properly, it is the inside surface of this hole which comes in contact with the axle, and not the hole itself. The corresponding part of an axle is called the *wheel-seat* or *wheel-fit*.

⊞

Babbitt-metal. "An alloy, consisting of 9 parts of tin and 1 of copper, used for journal-boxes; so called from its inventor, Isaac Babbitt, of Boston (patent, 1839). Some variations have been made, and among the published recipes are:

Copper.....	1	1
Antimony.....	1	5
Tin.....	10	50

Another recipe substitutes zinc for antimony.

The term is commonly applied to any white alloy for bearings, as distinguished from the box-metal or brasses in which copper predominates.—*Knight*.

Babbitt-metal bearing. A style of bearing of which a great variety of forms exist, which in effect substitute babbitt-metal in some of its many forms for brass as a bearing surface. *Lead-lined bearings*, which see, are different in that they merely use a thin sheet of lead over the brass, to correct slight irregularities and give an even bearing-surface. The bearing or brass should be bored out to remove scale.

Babcock fire-extinguisher. Fig. 3704. A device for causing the rapid generation of carbonic-acid gas when desired, by breaking a bottle of acid in the interior by means of the *bottle-breaking head* (the handle projecting up in the center of the top of the apparatus). The solution within consists of about 2½ lbs. of bicarbonate of soda in about 6 gallons of water.

Back. See *Seat-back*. *Slat seat-back*.

Back (for a pipe-clip). Fig. 2935. A metal strap sometimes used to attach the clips to, instead of attaching the latter directly to the surface to which the clip is attached.

Back-arm. See *Seat-arm*.

Back-band (car seat). 15, figs. 3917-25. The molding or metallic band that protects the top, bottom, and side edges of a seat-back. A *Seat-back molding*. Figs. 4023-8.

Back base-plate (Spear heater). Fig. 3058. See *Base-plate*.

Back cylinder-head (Westinghouse and other brakes). 4, figs. 1726-7. The cover for the end of a brake cylinder which has an opening in the center for the piston rod. For convenience of designation the end of the cylinder opposite to the piston rod is always called the *front* end and that adjoining the piston rod the *back* end, as in locomotives.

Back cylinder-head (Westinghouse tender brake). 4, fig. 1726.

Back face-plate. 4, figs. 2419-48. See *Gould-vestibule*.

Back face-plate (steel-tired wheels). The inner one of the two plates connecting the *tire* with the *hub*. See *Front face-plate*.

Back foot-rest (Hartley chair). 6, fig. 3998. See *Foot-rest*.

Back-frame (car seat). 47, figs. 3917-25.

Back-gravity-bar. 28a, figs. 2431-6. See *Gould vestibule*.

Back seat-bottom rail (longitudinal seat). 111, figs. 5666-7. A horizontal wooden strip at the back edge, to which a wooden seat-bottom is attached. See also *Front seat-bottom rail*.

Back seat-rail (street-car seats). 98, fig. 5656. A longitudinal strip of wood which extends along the back edge and is fastened to the window posts.

Back seat-rail (English). 152, figs. 501-2. In a carriage, a small transverse wooden bar secured to the partition and supporting the seat-boards.

Back squab (English). 197, figs. 501-4. American equivalent, *seat-back*. In a carriage, that part of the seat which fits the small of the passenger's back, and also supports the head and a fixed back, covered with broadcloth, and stuffed with curled horse-hair, and also made elastic by *springs* (which see).

Back squab sofa springs (English). 202, fig. 501. Analogous to the American *back-springs*. One end of these springs butts against the partition, and the other against a sheet of stout canvas, the back squab resting against the latter.

Back-stop-timbers. 212, figs. 229-66 and 278-82 and figs. 628-9, 647-8. Short sub-sills bolted and keyed by packing blocks to the center-sills of car in line with the draft timbers, to assist the draft or center sills, in transmitting the buffing shocks and strains. In the engravings it is called a *buffing sub-sill*.

Baggage-barrow. Figs. 5638-40. See *Barrow-truck*. *Baggage "wagon-truck"*.

Baggage-car. Figs. 139-141, 167, 555-6, 571-598. A car for carrying the baggage of passengers. A *combination baggage-car*, figs. 137, 599-604, is one having compartments set off for express or mail, or both. A *combination car* or *coach*, figs. 134-8, 175, 184, 430-1, 447-52, and 468-73, is a passenger-car with a baggage compartment. A *push baggage-car*, which see, is a light *larry car* for use at stations.

Baggage-truck. See *Baggage-barrow*, figs. 5638-9. *Baggage wagon-truck*, fig. 5640.

Baggage wagon-truck. Fig. 5640. A *four-wheeled* vehicle with a frame or rack for carrying baggage, used to move the latter by hand about railroad-stations. A *two-wheeled* vehicle is a *baggage-barrow*.

Bail. A curved handle of a more or less semicircular form for a pail, bucket, lantern, or other utensil. As applied to *lanterns*, figs. 3352-62; to *swing-barrel truck*, fig. 5635.

Bail (to Raoul journal-box). Figs. 5165-6. The latter is a yoke fastened to the sides of the journal-box, which passes over the lid and enables it to sustain the end-thrust of the axle.

Baker car-heater. Figs. 2865-2957. A stove invented and patented by Mr. Wm. C. Baker for warming cars. It is arranged so as to heat water in a coil of pipe in the the inside of the stove, and cause it to circulate through series of pipes laid near the floor of the car. The original heater has undergone many changes, and only those forms are shown that are in current use. They are: *The single-coil Fire-proof*, figs. 2865-84; *The Two-coil Fire-proof*, figs. 2885-2900; *The Perfected*, figs. 2901-2918; and *The Mighty Midget*, figs. 2919-29; with the parts belonging to them.

Ball-bearing butt-hinge. Figs. 2593-7. A butt-hinge, the washer of which is a ball bearing.

Ballast-plow. See *Rodgers ballast car and plow*.

Ballast wagon (English). American equivalent, *gravel car*.

A four-wheeled gondola car, fitted with falling doors at the sides and ends, and used for conveying ballast, rails, and ties.

- Band.** See *Auxiliary Reservoir-band.* *Guard-band.*
Belt-rail band. *Platform-timber band.*
Corner-band. *Seat-back band.*
Door-guard band. *Spring-band.*
Tank-band, etc.
- Band** (for seat-backs). Figs. 3939-40 and figs. 4033-8. More properly *Seat-back molding*, which see.
- Bar.** See *Body-bolster compression-bar.* *Centre-bearing inverted arch-bar.*
Body-bolster tension-bar. *Compression-bar.*
Bolt drawbar. *Cross-bar.*
Buffer-bar. *Pressure-bar.*
Draw-bar. *Rocking-bar.*
Draw-timber tie-bar. *Shackle-bar.*
Equalizing-bar. *Side-bearing arch-bar.*
Grate-bar. *Tension-bar.*
Guide-bar. *Tie-bar.*
Pedestal tie-bar. *Transom tie-bar.*
Centre-bearing arch-bar. *Truck-bolster guide-bar.*

Bar-lift. See *Bar sash-lift.*

Barnes center-draft draw-bar and coupler. Figs. 2282-7.

Barrel-car. Fig. 15. A flat car, racked so as to carry many empty barrels. They are made long, and the racks are very high in order to make up a carload weight.

Barrel door-bolt. Figs. 2535-8. A door-bolt made of a round metal bar and held on its slide in a round tube or "barrel." It is constructed so that when it is either engaged or disengaged from its keeper, it can be turned by a short lever or knob, and held in either position by suitable stops.

Barrel seat-lock. Figs. 4029-33. See *Seat-lock.*

Barrow-truck. Figs. 5638-9. This term has been used to designate two-wheeled vehicles used about railroads for moving freight and baggage by hand; but the more usual practice is to speak of baggage *barrows* and freight *trucks*, which see, although both are sometimes designated as *barrow-trucks*.

Barrett's double-acting lever-and-rack jack. Figs. 3740-1. A jack for trackwork consisting of a rack with sharp teeth, into which pawls engage as the lever is worked up and down. It is double-acting; that is, the load is lifted when the handle is lifted or thrust down.

Bar sash-lift. Figs. 4518-26. A sash-lift having a short horizontal metal bar attached to two flanged studs or stanchions; used for the large sashes of sleeping and drawing-room cars.

Bar shackle (of a padlock). Fig. 2763. A rectangular, instead of U-shaped, shackle.

Base. See *Lever-post base.* *Revolving-chair-stand base.* *Window-molding base.*

Base (Hartley chair). 12, figs. 3998-9. See *Pedestal.*

Barr vestibules. Figs. 2419, 2425-30. There are two types of vestibules designed by Mr. J. N. Barr, which are called the *Wing vestibule* and the *Toggle vestibule*.

1. Barr wing vestibule, Figs. 2419, 2425-8, was patented in February, 1890, and is manufactured by the Drexel Railway Supply Company, of Chicago. It is made up of folding walls, and does not require a rubber or canvas diaphragm between the face-plate and the car frame. It consists of a *face-plate*, 1, two *outer wings*, 2, in the place of the flexible diaphragm of the Pullman vestibule. The *outer wings*, 2, are hinged to the *face-plate*, 1, and also to the *inner wings*, 3, which are in turn hinged to the *end or corner post*, 5. The system of folding partitions is shown in more detail in the plans figs. 2427-8. This device dispenses with rubber diaphragms, permits the use of a single door, 7, at the side, gives two windows with wire screens for ventilation in the *inner wings*, 3. The top of the face-plate is kept forced out to meet its companion by its own gravity, bearing as it does upon the edge of a *footing or angle plate*, 13, which is to one side of the gravity line of the *face-plate*; the bottom is fastened to the platform

buffer. The tilting of the face-plate forward and backward is provided for by slotting the holes through which it is bolted to the *outer wing*, 2. The hinged wings permit lateral and longitudinal motion, yet exclude the dust and smoke.

2. The Barr Toggle-vestibule, figs. 2429-30, was patented in June, 1890, by Mr. J. N. Barr. It consists of a *face-plate*, 1, a *flexible diaphragm*, 2, inclosing the space between the *face-plate* and *end post*, 5. The distinct feature is the *toggle joint and bar*, 30, designed to keep the face-plate forced out, and in contact with the one opposite to it. It has a *threshold plate* and *double side doors*.

Barr contracting chill. Figs. 5364-7. A contracting chill invented by Mr. J. N. Barr, in which steam and cold water are alternately circulated in the chill for the purpose of keeping the frame of the chill of a uniform temperature so that the full effect of the elongation of the segmental block shall be obtained. See *Chill*.

Base (of ash-pit, Spear heater). Fig. 3059.

Base-board corner-molding. 206, fig. 560.

Base-burner. A furnace or stove in which the fuel is contained in a hopper termed the *magazine*, so that it is fed by gravity to the fire as the lower stratum burns away. The supply is thus continuous. The device is in principle very ancient, and it has been in general use for years.

Base-plate (of a derrick or crane). In figs. 390-1 and in figs. 392-3, the plate upon which 18 rests. A large plate placed on the floor of the car for supporting the mast. Another method is by a *mast-pocket*, which see.

Base-plate. (Spear heater.) See also *Back base-plate*. A cast-iron cylindrical ring, which forms the bottom part of the heater. It has openings for cold and hot air and carries the ash-pit doors.

Base-plate screen (Spear heater). Fig. 3060. A grating for covering the air opening of a base-plate.

Base-washer (passenger-car platform posts). 40, figs. 447, 461-6, 539 and 572. A metal ring or plate, which forms a bearing for the post on the platform end-timber.

Basin. 2, fig. 3468, and 1, figs. 3525-7. A hollow vessel made of porcelain or metal, and in cars usually fixed in a suitable stand with pipes and other attachments for filling it with water and emptying it. Such basins are used as lavatories in sleeping and other passenger cars. They are emptied at the bottom through a pipe connected to the basin by a *basin-coupling*, or *basin-bushing*, which is closed by a *basin-plug*. The basin-plug is attached to a *basin-chain*, which again is fastened to a stanchion called the *basin-chain holder*.

Basin-chain. Shown in fig. 3468. See *Basin*.

Basin-chain holder. Figs. 3483-4. See *Basin*. Frequently called a *basin-chain post* or *basin-chain stay*.

Basin couplings. Figs. 3469-75. See *Basin*.

Basin-plug. Figs. 3470-1. See *Basin*.

Basin-pump. 4, 5, 8, 9, fig. 3486, and figs. 3481-2. A pump of peculiar construction for supplying the basin of sleeping and parlor cars from the *tank* carried under the slab. It is called *single* or *double-acting*, according as the upward stroke only, or both the upward and downward strokes, eject water. Double-acting are most used. For names of parts, which explain themselves, see illustrations.

Basin-valve. 5, figs. 3525-7.

Basket-rack (English, parcel-net). Figs. 3753-70; 145, figs. 447, etc. A receptacle made of cast metal ends, rods, or a combination of rods and wire netting for holding parcels. They are attached to the sides of passenger-cars, above the heads of the passengers, so as to be out of the way. A basket-rack of extra length with exhaust ventilators at each end is shown at 7, fig. 2418. Continuous basket-racks extend the full length of the car and are increasing in favor. One is shown in A, fig. 541. Parlor cars usually have no basket-rack, but

sometimes *package-racks* are placed between the windows. Basket-racks are sometimes called *bundle-racks*.

Basket-rack bracket. Figs. 3767-70. A light metal or wooden support for the end or center of a basket rack.

Basket-rack netting. Figs. 3756-8. Wire or silk netting with very large meshes, which forms the bottom or back of a basket-rack.

Basket-rack rod. Figs. 3756-64. A small round metal bar which forms the main portion of a basket-rack, and to which the netting, when used, is fastened.

Basket-rack tip. Figs. 3757 and 3765. An ornamental knob or acorn on the end of a basket-rack rod.

Bastard Howe (freight-car framing). Figs. 59, 229-43, and 251. A style of framing having the vertical rods and inclined posts like the familiar Howe truss, but having also an upright post connected with the rod and serving more or less as a part of the truss. The Howe truss proper has been used in freight-car construction on the Pennsylvania Railroad, but it is no longer a standard of that road. See fig. 55.

Bastard Pratt framing. Is a similar modification of the Pratt bridge-truss, which differs from the Howe in having vertical posts instead of rods, and inclined rods instead of braces. A combination truss embodying the essential features of both the Howe and Pratt trusses is quite common in new construction. Figs. 244, 254, 261, and 263.

Batten. "A piece of board or scantling of a few inches in breadth."—*Webster*.

Batten wagon (English). A four-wheeled flat car about 24 feet long, fitted to carry sawed timber about 23 feet long, termed *battens*.

Bayonet-catch. A general term derived from the manner of fastening on a bayonet to a gun, applied to the mode used in many forms of hardware and mechanical construction for connecting separate parts so as to be firmly united and yet easily removable. Many lamps are held in place by a form of bayonet-catch.

Bay-window parlor-car. Figs. 115, 116, 122, 190, 193, and 547. A common style of parlor-car construction, designed to give more variety to the interior and improve the line of vision of the passenger.

Bead. "A small salient molding of semi-circular section. Also the strips on the sash-frame which form a guide for the sash. These beads are known as the *inside bead*, *outside bead*, and *parting bead*."—*Knight*.

In car construction the place of the *inside bead* is taken by the *window casing*, or *inside window-stop*; the place of the *outside bead* by the *outside window-stop*, and of the *parting bead* by the *sash parting-strip*, or *stop-bead*. The term is also frequently applied to any form of small, light molding of simple outline. See *Molding* and *Stop-bead*.

Bead molding (English). See *Bead* and *Planted molding*.

Beam. "The term *beam* is generally applied to any piece of material of considerable scantling, whether subject to transverse strain or not; as, for example, 'collar-beam,' 'tie-beam,' 'Brestsummer-beam,' the two former being subject to longitudinal strains of compression and tension respectively, and the latter to transverse strain."—*Stoney*.

1. "Any large piece of timber, large in proportion to its thickness and squared or hewed for use."—*Webster*.
2. A bar of metal of similar proportions is also called a *beam*.
3. "A bar supported at two points and loaded in a direction perpendicular or oblique to its length is called a *beam*."—*Rankine*.

By analogy the term has of late years come to be applied to similar pieces or bars of iron. Thus we have iron *I-beams* and *deck-beams* (which see), to take the place of wooden beams in buildings. The term is also used to designate such things as the *beam of a balance* or

scales, a *plow-beam*, the *walking-beam* of a steam engine, *brake-beam*, etc.

See *Auxiliary-reservoir beam*. *Middle safety-beam*
Brake-beam. *Needle-beam*.
Buffer-beam. *Platform-truss beam*.
Buffer-spring beam. *Safety-beam*.
Center-beam. *Spring-beam*.
Center-bearing beam. *Suspender-beam*.
Compression-beam. *Swing-beam*.
Drop-door beam. *Truss-beam*.
Floor-beam. *Trussed brake-beam*.

Beamless brake-rigging. Fig. 1601. A method of hanging the brakes to a truck-frame and a system of levers and rods by which the *brake-shoes* are applied to the wheels without the use of *brake-beams*. One form, fig. 1601, shows the shoe attached to a lever whose fulcrum is the extension of the arch-bar and tie-bar of the truck-frame. It is not at present much in use, but is illustrated as a type of beamless brake.

Bearing. That which supports or rests on something, and is in contact with it. Thus a block or stone on which the end of a timber rests is called a *bearing*. The metal block or bushing in contact with a journal is called a *bearing*.

For M. C. B. standard *journal-bearing* see figs 5389-5418.

See *Axle safety-bearing*. *Rocker side-bearing*.
Body Truss-rod bearing. *Safety-beam truss-rod bearing*.
Brake-hanger bearing. *ing*.
Brake-shaft bearing. *Side-bearing*.
Center-bearing. *Spring-plank bearing*.
Crank-shaft bearing. *Stop journal-bearing*.
Cup side-bearing. *Stop-key journal-bearing*.
Dust-guard bearing. *Swing-hanger-pivot bearing*.
Half-elliptic-spring bearing. *Truck-bolster truss-rod bearing*.
Journal-bearing. *ing*.
Lead-lined journal bearing. *Truck side-bearing*.
Lever-shaft bearing. *Truss-rod bearing*.
Lower brake-shaft bearing. *Upper brake-shaft bearing*.
Rocker-bearing.

Bearing-casting (Tip-cars). 17, 18, figs. 336-42. A casting (one of a pair) attached to either the car body or to the truck which supports the car body and its loads. In tip-cars it is pivoted or hinged so as to permit the body to tip or rock laterally and to thus discharge its load.

Bearing-spring. An occasional but not the conventional term for the *bolster-springs* or main springs of the car.

Bearing-spring (English). 22, figs. 348-51 and 501-4. American equivalent, *bolster-spring*. The spring which carries the weight of the vehicle, and rests on the *axle-box*. In English practice almost invariably a half-elliptic spring.

Bearing-spring buckle (English). 23, figs. 348-51 and 501-4. An American equivalent, *spring-band*. A solid wrought-iron strap which confines the plates of the *bearing-spring*, and is generally provided with lugs on the lower side, so that it cannot be moved transversely or longitudinally on the *axle-box*. The plates are secured to the buckle by a $\frac{3}{4}$ -in. vertical rivet.

Bearing-spring shoe (English). 24, figs. 348-51. A cast-iron lipped rubbing piece, secured to the under side of the *sole-bar* on which the ends of the *bearing-spring* bear.

Beasley's seal-lock. Figs. 3399-a. This is a seal-lock which registers the number of times the car is opened and closed.

"Bee" door-spring. Fig. 2816. See *Door-spring*.

Bell. See *Recording-bell*. *Signal-bell*. *Smoke-bell*, etc.

Bell-base jacks. Fig. 3733. A *jack* the bottom of which is cast in the form of a bell. See *Screw-jack*.

Bell-cord. Fig. 2471 and in fig. 422. A rope one end of which is attached to a signal-bell on the engine, and which extends through or along the tops of the cars the whole length of the train, and is used for signaling to the locomotive engineer. It is carried by various forms of *bell-cord bushings*, *bell-cord hangers*, and *bell-cord-guides* (which see). On freight trains, when used at

all, which is the exception, it is placed on the outside, and on top of the roofs of the cars, but in passenger trains it is attached to the rafters or purlins by suitable supports, on the inside of the cars. On passenger trains, the *bell-cord* is made of lengths equal to that of each car, and is fastened together with suitable *couplings*. Bell-cord is made of flax, hemp, and sometimes of leather, and is known by the following names in trade: *Brass-wire covered*; *fancy braided*; *flaxen*; *Italian hemp*; *solid leather*; *solid braided*. The usual sizes are $\frac{1}{4}$ -in. and $\frac{3}{8}$ -in. diameter.

The bell-cord was first used by William Hambright, a locomotive engineman, in 1833, on the old horse-power railroad between Lancaster, Pa., and Philadelphia. Hambright affixed a common bell to the interior of the engine cab, and ran a rope backward through the interior of the car. The rope, in its present form, was devised by Captain E. A. Ayres, of the Erie Railway. The English term for a cord to answer the same purpose in a different way, is *communication-cord*, which see.

Bell-cord beveled-bushing. Figs. 2458-9. See *Bell-cord bushing*.

Bell-cord bushing. Figs. 2454-63. A thimble lining a hole through a partition for a bell-cord to pass through; in distinction from a *bell-cord guide*, which is attached to the side or roof of the car or to a bell-cord hanger and serves solely the purpose which its name implies. For passing the bell-cord through inclined surfaces *beveled-bushings* are used, which are frequently provided with one or more *pulleys* to avoid friction.

Bell-cord coupling. Figs. 2464-9. The hook attached to the end of a bell-cord to enable it to be connected or disconnected at pleasure with another bell-cord; not to be confused with a *bell-cord splice*, figs. 2470, 2473-4, which is intended as a permanent connection.

Bell-cord end-hook. A common metal hook with a screw-shank by which it is attached to the end of a car. The hook is used to fasten the end of a bell-cord to the last car and thus hold it in its place, and prevent it from being drawn out of its guides.

Bell-cord guide. Figs. 2454-2502. A metal eye or ring attached to the roof or ceiling of a car, or to the end of a *bell-cord hanger* (which see), and by which a bell-cord is carried or conducted. According to their method of attachment to the car they are designated as bell-cord guides, *with flange*, or *with screw*, or *with screw and flange*, and they are often provided with one or more pulleys, and are sometimes swiveled, when the bell-cord is to be conducted in an oblique line. Figs. 2490 and 2500. The pulleys are ordinarily at the bottom, but sometimes at the side of the bell-cord guide, according to the direction of probable strain. Certain tube-like forms of bell-cord guides are occasionally miscalled *bell-cord bushings*, which see.

Bell-cord-guide washer. An ornamental washer for making a finish for a bell-cord guide where it is attached to a car roof.

Bell-cord hanger. Figs. 2503-26. A guide for the bell-cord, hanging usually from the center of the clear-story or upper deck. In its original form it consists of a *bell-cord strap*, attached to a *bell-cord strap-hanger bracket*, which latter is screwed to the top of the car. The simpler forms of these brackets, as figs. 2519-23, are called *screw-tops*. The lower end of the strap carries a ring called the *bell-cord guide*, which latter is often provided with a pulley at the bottom to obviate friction. To avoid unpleasant vibration, the *double strap-hanger* has been used, giving lateral stability, and recently *bell-cord rod-hangers*, figs. 2519-23, have been introduced, swinging on a pivot. *Bell-cord fixed-hangers*, fig. 2514, are used where the drop is small.

Bell-cord hanger-straps. Figs. 2527-34. See *Bell-cord hanger*.

Bell-cord chain-hanger. Figs. 2517-18, 2524.

Bell-cord hanger bracket, or screw-top. Figs. 2505-7 and 2519-20. See *Bell-cord hanger*.

Bell-cord pulley, or sheave. Figs. 2485-2502. A wheel in a bell-cord guide over which a bell-cord runs.

Bell-cord rod-hanger. Figs. 2520-21. See *Bell-cord hanger*.

Bell-cord sheave. A *bell-cord pulley*, which see.

Bell-cord splice. Figs. 2470 and 2474. A metal coupling with right and left hand screws for *permanently* splicing the ends of a broken bell-cord. See *Bell-cord coupling*.

Bell-cord strap. Figs. 2527-34. See *Bell-cord hanger*.

Bell-cord strap-hanger. Figs. 2527-34. See *Bell-cord hanger*.

Bell-cord strap-hanger bracket. Figs. 2503-15. See *Bell-cord hanger*.

Bell-cord strap-hanger screw-top. Figs. 2519-20. See *Bell-cord hanger*.

Bell-cord thimble. A *bell-cord bushing*, which see.

Bell-crank. An L-shaped rectangular lever, often with the two extremities connected so as to be of triangular form, for changing the direction of motion by 90 degrees, more or less.

Bell-crank (hand-car). 23, figs. 5592-5600. A crank attached to the propelling lever shaft giving more favorable direction to the power applied to the levers.

Bell-crank (of sofa-pull). Fig. 4138.

Bell-crank (Driver-brake). 13, fig. 1749.

Bell-crank driving-wheel brake (American Brake Co.'s brake-gear). Fig. 1749. One of the styles of driving-wheel brake-gear manufactured by the company referred to, taking its name from the peculiar manner of applying the brake power, as shown in the illustration.

Bell-crank pin (Driver-brake). Fig. 1749.

Bell-punch. An instrument for punching a hole on a recording slip of paper or tickets, so as to register the fares collected by a conductor. The instrument has a bell attached which is rung every time a fare is recorded by punching the paper or ticket. The bell is intended to indicate or announce to the passengers that the conductor has recorded the fares collected. These instruments are made in a variety of forms. The punching of the slip is now usually omitted, the device being then simply an *alarm register*, often made of large size and attached to the side of the car. See *Fare register*.

Bell-rope. A *bell-cord*, which see.

Bell's exhaust hopper-ventilator. Figs. 3841-2. An attachment placed underneath the *floor-pipe* of a *closet-hopper*, on the under side of a passenger-car to produce a downward draft through the hopper when the car is in motion. The attachment is of a concave conical form, which by the motion of the train in either direction causes the air to pass downward through the floor-pipe by creating a partial vacuum at the base.

Bell-strap (street-car). 98, fig. 5654. A leather strap which extends along the under side of the rafters, from a signal bell on one end of the platform to one on the other end; used by the conductor to signal to the driver, and by the driver to signal to the conductor.

Bell-strap bracket. A *bell-strap guide*, which see.

Bell-strap guide (street-car). A metal loop or bracket attached to the ceiling of a street car for carrying a signal-strap. They are frequently provided with rollers and have either *screw tops* or *flanges*.

Belt-molding. A molding passing entirely around the interior of the passenger-car directly above the windows, in the middle of the wide board called the inside lining.

Belt-rail. 65, figs. 440, 456, 540, 550, 560. A part of the framing of a passenger or street car frame below the windows on the outside, extending the whole length of the car-body and attached to each post. It is usually framed into the posts and supports the window-sills. The term is often applied to the *girth* of a box-car. The

- upper belt-rail*, 82, of the same figs., is a similar strip directly above the window.
- Belt-rail band** (street-cars). 35, figs. 5654-67. An iron band on the outside of a belt-rail covering the joint of the latter with the panel. It extends around each corner of the car to the door-posts.
- Belt-rail cap**. 81, figs. 540, 551, 560. A thin strip of wood nailed to the top of a belt-rail, and which forms a seat for the window-sill.
- Bemis truck** (street-cars). Fig. 5646. A four-wheeled truck for long street-cars, two being required for a car.
- Bench-cap**. 0, figs. 325-7. Transverse timbers resting upon the *side-rails* of a coal or ore car, to tie the rails together and prevent spreading, and also to support the doors or winding shaft about which the *winding-shaft chain* is wound.
- Bend** (for iron pipes). Figs. 2940, 2945-6, etc. See *Return-bend*. They are distinguished as *close* and *open* return-bends.
- Bent ladder-round**. Fig. 5546. The lower round of the ladder of box-cars, having an angle turned up at the inside for the safety of trainmen, to prevent the foot slipping off the ladder-round. The use of such rounds has been recommended by the M. C. B. Association. See *Ladder and Ladder-round*.
- Berth**. 1, 2, figs. 2409-12. A bed in a *sleeping-car*, which see; also, the shelf or support on which the bed rests. There are two such beds in the space occupied by two double seats, which is called a *section*. The *lower berth* is made upon the seats and the upper one on a shelf, which can be raised or folded up out of the way in day-time, as shown in fig. 2410. A full section with both the upper and lower berths made up is shown in fig. 2411. Some recent improvements are shown by comparison of figs. 2408 and 2409. See *Lower berth*. *Upper berth*.
- Berth-arm**. A *berth-brace*, which see.
- Berth-bolt**. See *Berth-latch bolt*.
- Berth-brace**. A metal rod, chain, or wire rope sometimes attached to the side and near the top of a sleeping-car, and at the other end to the outer edge of a berth, which is supported by the brace. When a metal rod is used, it usually has a joint so that it can fold up like an ordinary two-foot rule, when the berth is raised up. In the later designs it is done away with, the berth being supported by the *berth-chain*.
- Berth-brace-eye**. A metal plate with suitable lugs for fastening the brace to the top of the car or to the berth.
- Berth-bracket**. Fig. 4169. A bracket on which an upper berth of a sleeping-car rests when lowered and the bed is made and in use.
- Berth-catch** (emigrant sleeping-berths). Figs. 4264-6.
- Berth-catch and plate**. Figs. 4143-4.
- Berth-chain**. 25, figs. 2409 and 2412; C, fig. 4198 and 4208. A pitch-chain passing from the *berth-spring* through the *overhead-pulley* and to the corner of the upper berth to support it. The *berth-spring* is attached to the chain to counteract the weight of the berth. The *berth-chain* does the service of the *berth-spring rope* and *berth-brace*.
- Berth-chain end-plate**. See *Berth-spring lug*.
- Berth-chain pulley**. 24, figs. 2411-12. L, 4198 and 4208. A pulley attached to the roof of a sleeping-car, over which a berth-chain runs.
- Berth-curtain**. 17, figs. 2409-12. A curtain hung in front of a sleeping-car section to hide the occupants from sight. A single curtain covers both berths, and the privacy of the lower berth is secured by a second curtain. In boudoir cars there are separate curtains for each berth, fig. 2418.
- Berth-curtain hook**. Figs. 4223-6. A metal hook attached to a berth-curtain, and by which the latter is hung on a rod above the berths; usually covered with leather to prevent rattling.
- Berth-curtain pole**. See *Berth-curtain rod*.
- Berth curtain-rod**. 16, figs. 2409-12 and fig. 4194. A rod usually made of metal tubing, fastened above a section of a sleeping-car and to which a *berth-curtain* is hung. They are now made in sections, supported by folding brackets, and swing into the upper berth out of sight, except when berths are made up. See *Berth curtain-rod bracket*.
- Berth curtain-rod acorn**. See *Berth curtain-rod tip*.
- Berth curtain-rod bolt**. In Figs. 4209-17. A small vertical bolt, usually tipped with an acorn, fastening the *curtain-rod* in the *coupling* on the *bracket*.
- Berth curtain-rod bracket**. 15, figs. 2409-12 and figs. 4209-17. A metal bracket attached to the deck side of a sleeping-car, which forms a support for a berth curtain-rod. Such brackets usually have a coat and hat hook attached to them. A *hanger*, fig. 4209, is sometimes used as a substitute for a bracket at certain points. The stationary bracket is being replaced by the folding curtain-rod bracket, which folds, with the rod attached, into the upper berth and out of sight when the curtains are not in use. See *Curtain-rod folding-bracket*.
- Berth curtain-rod coupling**. Figs. 4209-17. A fastening by which a berth curtain-rod of a sleeping-car is secured to a bracket. It usually consists of a bolt or screw.
- Berth curtain-rod hanger**. Fig. 4209. See *Berth curtain-rod*.
- Berth curtain-rod socket**. Figs. 3614 and 3618. A metal flanged ring which is fastened to some part of a sleeping-car to carry the berth curtain-rod, also called *berth curtain-rod bushing*.
- Berth curtain-rod tip, or acorn**. See *Acorn*.
- Berth extension-arms**. Fig. 4182.
- Berth fixtures, etc.** Figs. 4145-4271.
- Berth-front**. R, fig. 514. The bottom of the upper berth when it is down. There are two parts: the upper part marked R, and the lower part, which is adjacent to the car-side. The berth-front panel is between these two berth fronts.
- Berth-front borders and corners**. Figs. 3656, 3659.
- Berth-handle**. A *berth-latch handle*, which see.
- Berth headboard**. 9, figs. 2409-12. See *Headboard*.
- Berth head-rest pivot and plate**. Figs. 4154-5.
- Berth-hinge**. Figs. 4147-8, 4183-6, 4189, 4192-3, and 4253-6. A hinge or joint by which the back edge of an upper berth of a sleeping-car is attached to the side of a car. They are distinguished as *loose* and *fast*. Fast hinge is shown in fig. 4189. The loose hinge fits in a *plate* or *bushing*. Shown with the hinges.
- Berth-hinge bracket** (emigrant sleeping-berths). Figs. 4253-4.
- Berth-hinge bushing**. A hollow metal socket in which the spindle of a loose *berth-hinge* works.
- Berth-hinge plate**. Figs. 4147, 4193. A plate which takes the place of a *berth-hinge bushing*.
- Berth-lamps**. Figs. 4237-44. Electric lamps for the berths of sleeping-cars. There are two:
1. The *Pullman*, which is detachable, being carried on a bracket, which may be inserted in a socket at the side of the car, and the current being taken from another socket by an insulated wire joining it with the lamp.
 2. The *Gibbs* is fixed in the partition between two berths, and the one lamp may light two berths, there being a metallic cover or slide which shuts it off at any time from either side of the partition.
- Berth-latch**. 47 and 48, figs. 2409, 4195-7, 4200-5. A spring bolt for holding the upper berth of a sleeping-car up in its place when not in use. To obviate the danger of the berth shutting up in case of overturning of the car, the *safety-berth rope* and attachments, 26, figs. 2409-12, are used. *Safety-berth latches* have also been used to obviate the necessity of using a safety-rope. See *Safety-berth latch*.
- Berth-latch bolt**. 48, figs. 2409-12, and 6, figs. 4195-7.

- The bar or pin of a berth-latch which engages in a corresponding strike-plate or keeper to hold the berth up.
- Berth-latch face-plate.** Figs. 4218-22.
- Berth-latch handle.** 47, figs. 1209-12 and 4218-22.
- Berth-latch keeper.** H, figs. 4200-5. Also called *strike-plate*, which see. See *Berth-latch bolt*.
- Berth-latch lever.** D, figs. 4200-5. The part by which the *berth-latch handle* operates the *berth-latch bolt*; also called a *berth-latch rocker-plate*.
- Berth latch- (or lock) plate and bolt.** Figs. 4173-3.
- Berth latch- (or lock) rods.** Fig. 4191.
- Berth-latch rocker-plate.** See *Berth-latch lever*.
- Berth-latch shell.** A metal covering made in the form of a sea-shell for covering and protecting the handle of a berth-latch in a sleeping-car.
- Berth-lock.** A *berth-latch*, which see.
- Berth-mattress.** 18, fig. 2409. The mattresses which cover the seat-cushions of the *lower berth* and the springs of the *upper berth*. When the berths are made up for day travel the mattresses are stored in the upper berth, as shown in the figure.
- Berth-numbers.** Figs. 4228-32. Figures or numbers, usually made of metal or porcelain, for numbering the berths or sections of sleeping-cars. They are frequently sewed to plush panels and hung from the berth curtain-rods.
- Berth or bunk partition.** 8, figs. 2409-12. The partition between the upper berths of two adjacent *sleeping-sections*. It is of the same outline as the upper berth's cross-section.
- Berth pivot.** Fig. 4153.
- Berth-pivot socket.** Figs. 4149-50.
- Berth-rattle stop.** Figs. 4145-6, 4206.
- Berth-rest.** See *Upper-berth rest*.
- Berth-rest (double).** (Emigrant sleeping-berths.) M, figs. 2413-14. A shoulder carried upon the upright *berth-posts* as a support to the outer edge of the upper berths.
- Berth-rest (end).** (Emigrant sleeping-berths.) N, figs. 2413-14 and 4259-62.
- Berth-rest (upper).** (Emigrant sleeping-berths.) L, figs. 2413-14.
- Berth-rest bracket (upper).** Fig. 4169.
- Berth-rest plate.** (Emigrant sleeping-berths.) K, figs. 2413-14.
- Berth-rest plate (upper).** (Mann boudoir car.) 11, fig. 2418.
- Berth safety-latch handle, in place attached to car.** 47, figs. 2409-12. See *Safety berth-latch*.
- Berth safety-rope.** 26, figs. 2409-12. A wire rope fastening the upper berth of a sleeping-car to the fixed arms of the lower berth, to prevent accidental closing up of the upper berth in case of overturning of the car. The rope is fastened to the upper berth by a *berth safety-rope fastener* and to the lower berth by inserting a *knob* into a *berth safety-rope holder*.
- Berth safety-rope fastener.** See *Berth safety-rope*.
- Berth safety-rope hook.** Fig. 4227.
- Berth safety-rope holder.** See *Berth safety-rope*.
- Berth safety-rope knob.** See *Berth safety-rope holder*.
- Berth spring.** 23, figs. 2409-12, figs. 4199 and 4207-8. A spring usually made in a spiral form, like a watch spring, coiled within a device called the *berth-spring fusee* and attached to the upper berth of a sleeping-car by a *berth-chain* so as to counteract the weight of the latter and make it easy to raise and lower it.
- Berth-spring frame.** 23, figs. 2409-12 and figs. 4199, 4208; 1, figs. 1249-51. A metal support which holds a berth-spring and fusee.
- Berth-spring fusee.** See *Fusee*.
- Berth-spring lug, or clip.** M, fig. 4198. The means by which the end of a berth-chain is fastened to the upper berth, sometimes called a *berth chain end-plate*.
- Berth-spring rope.** Fig. 4207. A cord, usually made of wire, which is connected to an upper berth of a sleeping-car at one end, and to the berth-spring at the other, and by which the tension of the spring is transmitted to the berth, thus counteracting its weight. Instead of the rope a *pitch-chain* is now used.
- Berth-stop (emigrant sleeping-cars).** Fig. 4247-8. A bearing-plate carried on upper berth at K, figs. 2413-14, to afford a bearing on the *berth-rest*, M.
- Berth striker-plate.** A *berth-latch keeper*, which see.
- Beveled-bushing.** Figs. 2458-9. See *Bell-cord bushing*.
- Beveled-washer.** Figs. 3717-8. A washer used to give an even bearing for rods which stand at an acute angle to the surface on which the nut or bolt head bears. Sometimes two such washers which come near together are cast in one piece, and are then called *double-beveled washers*. See *Triangular washer*.
- Bezel.** "A term applied by watchmakers and jewelers to the groove and projecting flange or lip by which the crystal of a watch is retained in its setting. An *ouch*." —*Knight*. Hence, *Globe-bezel* (Pintsch gas-burner). 307, figs. 3238-42.
- Bibb.** A curved nozzle for conveying liquids and changing the direction of their flow, usually from a horizontal to a vertical current. Hence—
- Bibb-cock.** Figs. 3491-2. Literally, a cock with a curved nozzle or spout, but commonly restricted to a cock with a plain valve without springs, moved by the hand only.
- Bird (F. W.) car-roof.** Figs. 2393-4. See *Car-roof*, and *Neponset roof*.
- Bissell heater.** A hot-air heater, taking in cold air by a *wind-scoop* and distributing it by pipes along the floor.
- Bissell stop-key journal bearing.** Figs. 4970-3 and 5133-7. One with a projecting shoulder on the journal-bearing key to take up the end-thrust, so as to dispense with a collar. See *Journal bearing*. Also called *stop-wedge journal-bearing*. See *Journal-bearing key*.
- Bit (of a key).** Figs. 2714-21 and 2767. The part of a key which enters the lock and acts upon the bolt and tumblers. The bit consists of the *web* and *wards*. The *web* is the portion left after the wards are cut out. The *wards* (of a key) consequently are those parts of the bit which are not there and fit over the *wards* of a lock, which see. Some bits have no wards.
- Bit (of a padlock).** E, figs. 2771-2. The forward end of the sliding-bolt, which engages with the shackle in the act of locking.
- Bit or jaw-bit (passenger car trucks).** A short bar closing the mouth of the jaw of a pedestal after inserting the journal-box. It is little used.
- Blackstone car-coupler.** A form of platform invented by Mr. T. B. Blackstone, President of the Chicago & Alton Railroad, and used only on that road. It has projecting bars, which engage with the opposite platform to prevent one car from rising above the other and thereby lessening the danger of telescoping.
- Blake butt.** An indefinite term, meaning in general a plain cast-iron butt-hinge, having a washer, but no acorns or screw-pin.
- Blank hinge.** A hinge which permits the door to swing open in either direction. It is intended as a substitute for one of a pair of *double-acting spring hinges*, which see, as being lighter and cheaper.
- Bleeding-cock.** A small cock on the *auxiliary reservoir*, etc. Generally called a *drain-cock*.
- Bleeding-valve or Bleeding-cock.** 18, figs. 1693-8. Another term for *release-valve* or *release-cock*. The operation of releasing the brake when applied upon a car detached from the locomotive is sometimes called *bleeding*. The bleeding-valve is located in the auxiliary reservoir, and the brakes may be released by opening it.
- Bleed-valve (Frost light).** Figs. 3127-8 and 6, figs. 3121-3. A valve of the *carburetor* of the *Frost system of gas lighting*, which is attached to the *filling-can* and affords a *vent* which permits the *gasoline* to flow freely from the can. The operation is shown in fig. 3153.

Blind. 140, fig. 435. A *window-blind*, which see. They are sometimes *single*, but usually *double*, and then distinguished as *lower* and *upper*. *Flexible window-blinds* are rarely met now, having been displaced by *window-shades*.

Blind lifts, bushing, bolt, etc. Figs. 4403-64. See *Window-blind lift, etc.*

Blizzard. A fierce storm with high wind. Hence the trade name *blizzard signal-light*, fig. 3323, to designate one of extra quality, with careful provisions to prevent extinction by wind. See *Signal-light*.

Block. 1. "A heavy piece of timber or wood, usually with one plane surface; or it is rectangular and rather thick than long."—*Webster*.

2. Fig. 3623; 2, figs. 207, 391, and 395. "A pulley or system of pulleys mounted on its frame or shell, with its band or strap. A block consists of one or more pulleys or sheaves, in a groove of which the rope runs, fastened in a shell or frame by pins on which they revolve; of a shell or frame inclosing the pulley or pulleys; and of a strap or band, consisting of a rope, encompassing the shell, and attached by an eye of rope or a hook to some object."—*Ed. Ency.*

The interior wheels are termed *sheaves*, which latter term is often used to designate the whole block or pulley, but incorrectly. A *snatch-block* is a block with only one sheave and with an opening at the side for the ready insertion and removal of the rope. Blocks without this opening, however, are sometimes loosely termed *snatch-blocks*.

See *Body-bolster spacing block.*

Body-bolster truss-block.

Brace-block.

Buffer-block.

Brake-cylinder block.

Distance-block.

Floor-timber distance-block.

Follow-up-plate block.

Guide-block.

Packing-block.

Safety-beam block.

Spring-block.

Stirrup-block.

Stop-block.

Centre-plate block.

Dead-block.

Swing-hanger friction block.

Transom bearing block.

Transom truss-block.

Truck-bolster guide-block.

Truck-bolster truss block.

Truss-block.

Block and tackle. A general term applied to a pair or more of pulleys and accompanying rope. Also termed *fall and tackle*, or simply *tackle*.

Block-car. A car generally attached to wrecking trains, behind the wrecking-car proper, for carrying blocking, ropes, chains, and other tools. Usually a common box-car, sometimes fitted up with bunks.

Blocking. 59b, figs. 532-8. A mode of securing together the vertical angles of woodwork by blocks of wood glued or nailed in the inside angle. The method is largely used in every form of carpentry, where great strength is not required in the joint. In carwork, generally known as *furring-blocks*.

Blocking-strip. See *Floor blocking-strip*.

Blow-off valve (special). (Gold car heating). Fig. 3007. See *Excelsior steam-trap, etc.*

Board. "A piece of timber sawed thin, and of considerable length and breadth, compared with the thickness, used for building and other purposes."—*Webster*.

See *Brake foot-board.*

Deck soffit-board.

Eaves fascia-board.

Fender-board.

Headboard.

Inside-cornice fascia-board.

Inside-cornice sub-fascia board.

Letter-board.

Roof-boards.

Roof running-board.

Running-board.

Seat-back board.

Soffit-board.

Splash-board.

Tread-board.

Boarding-car. Figs. 165-6. A car fitted up for cooking and serving meals to men at work on the line of a road. It is sometimes fitted with sleeping-berths and bunks.

Board roofs (freight-cars). A very indefinite term, usually meaning either one with a double layer of boards only, with or without painted canvas or other packing, or a

single layer of boards covered with sheet metal. Figs. 2385-8. The Winslow and other roofs have boarding over the metal sheets. Figs. 2355-78 and 2380-4. A plain double roof is shown in fig. 2379.

Bob-tail street-car. A term used to designate a street-car with a platform in front only and a small step behind. Such cars are usually drawn by one horse only.

Body. 1. (Of a car). Figs. 229-615. The main or principal part in or on which the load is placed. American cars for steam railroads usually consist of a body carried on two trucks. Street-cars are usually carried on four wheels only.

2. (Of a valve cylinder, etc.) The main or principal part, to which the other parts are attached, as *cylinder-body, etc.*

Body-bearing hinge-casting. 17, figs. 336-42. See *Bearing-casting*.

Body-bolsters. Figs. 1428-57; also 12, figs. 229-66 and 410-13; 10, figs. 435-73; Freight Car Bolsters, figs. 1428-50; Passenger, figs. 1451-7. Cross-beams attached near the ends of the under side of a car-body which is supported on two trucks. The body centre-plate and side-bearings, which rest on the truck, are fastened to these bolsters. Such beams are made of wood, or of iron, or steel trussed, or of wood and iron combined. A body-bolster is sometimes called *body-transom*, or simply *transom*, but the term *body-transom* is more properly applicable, if used at all, to the *needle-beams* passing from side to side of the car between the trucks; also known as *cross-frame tie-timbers*, or *cross-bearers*. A part analogous to a body-bolster and frequently called the *Body bolster* is the *bunk* of logging-cars, figs. 12, 352-4; but this rests above a reach connecting the trucks, corresponds more properly to the only car-body as it sustains the load. The body-bolsters of passenger-cars are sometimes very elaborate structures, as the *double iron body-bolster*, figs. 1455-7. Iron body-bolsters are in the form of a truss, the top member being known as the *top plate* or *tension-bar*, and the bottom as the *bottom plate* or *compression bar*, the two being held apart by small castings called *body-bolster thimbles*.

Body-bolster compression-bar. 2, figs. 1428-57, and 12b, figs. 229-66. See *Body bolster. Bottom plate*.

Body-bolster end pocket-casting. Figs. 933-5. A cast cap that fits over the end of a composite body bolster, through which the truss-rods pass, and on which the *truss-rod nuts* bear. It is a body-bolster truss-rod washer enlarged so as to cover the entire end of the bolster.

Body-bolster fitch-plates. 12A, figs. 287-9; figs. 1428-30. Plates of iron or steel sandwiched in between pieces of wood and bolted together to give it greater strength. Frequently called *Body-bolster sandwich-plates*.

Body-bolster sandwich-plates. See above.

Body-bolster spacing-blocks. 12', figs. 229-66. See *Body-bolster*.

Body-bolster tension-bar. 1, figs. 1428-57, and 12a, figs. 229-66. See *Body-bolster. Top-plate*.

Body-bolster thimble. 3, 4, 6, figs. 1428-57. See *Body-bolster*.

Body-bolster truss. Figs. 1455-7. See *Body-bolster*.

Body-bolster truss-block. 15, figs. 229-66, 355-72, and figs. 1428-70. A block of wood or distance-piece, on the top of a wooden body-bolster, between the center floor-timbers and underneath the bolster truss-rods.

Body bolster truss-rod. 13, figs. 229-66, 355-72; and 11, figs. 435-73. A rod which lies parallel with and passes above the center of the bolster over the *truss-rod bearing* so as to form a truss; generally two are used for each bolster.

Body-bolster truss-rod bearing. Figs. 1428-30. See *Body-bolster truss-rod*.

Body-bolster truss-rod saddle-straps. 13a, figs. 283-6, 298-315, etc. Straps that connect the truss-rods passing

diagonally through the two ends of the body bolster. The strap is a flat bar of iron about $3 \times \frac{1}{4}$ inch with a rectangular bend at the ends into which the truss-rod heads fit, as in figs. 1428-30. These straps bear upon the center-sills.

- Body-bolster truss-rod washer.** 14, figs. 229-66; 12, figs. 435-73, and 1428-57. An iron bearing-plate on the end of a body-bolster; often made to take two or more rods.
- Body-brace.** 33, figs. 229-66; 51, figs. 435-73, and 637-44; 55, figs. 570-83. An inclined beam or strip of timber in the side or end frame of a car-body, which acts as a brace. A substitute for body braces as well as for truss-rods is the *Challender truss*, figs. 568-9, which see. A *compression-beam brace*, 164B, fig. 536, answers to the definition of a body-brace, but is a *long brace*, constituting with the *compression-beam*, 164, a single truss or arch from bolster to bolster. A *body-brace* is an oblique brace in one of several panels included in this space. See *Brace*. *Body counter-brace*. *End body-brace*, 35, figs. 229-66, and *Side body-brace*.
- Body brace-rod.** 34, figs. 229-66; 52, figs. 435-73. An inclined iron rod in the side or end of a car-body frame, which acts as a brace. They are distinguished as *End* and *Side body brace-rods*. A *brace straining-rod* is a short vertical rod in the side of a passenger-car under the window; 53, figs. 435-73.
- In figs. 435-73, the rod 167 and 220 has been improperly called *body brace-rod*. The proper term to be applied to this rod is *overhang brace-rod*. See also *Inverted body truss-rod*, or *Hog-chain rod*.
- Body center-plate.** 11, figs. 1428-57; 17, figs. 229-66; 15, figs. 435-73. The upper of the two *center-plates*, which see, through which the *king-bolt* or *center-pin* passes.
- Body check-chain eye.** 19, fig. 447. An eye-bolt or clevis for fastening a check-chain to the car-body. See also *Truck check-chain eye*.
- Body check-chain hook.** Fig. 1313. An iron hook on the *check-chain* which enters into the *check-chain eye*.
- Body counterbrace.** 37, figs. 229-66, 355-72; 55, figs. 435-73; details, 641-4. A brace in the side-frame of a car-body between the bolsters and the end of the car. These braces are inclined in a direction opposite to those between the bolster and centre of the car. Sometimes counterbraces are inserted in the central portion of the car between the two bolsters. They are then termed *center counter-braces*. See *Counter-brace* and *Framing*.
- Body counter-brace rod.** 37', figs. 229-66; 56, figs. 435-73. Usually an inclined iron rod in the side-frame of a car-body, between the bolster and the end of the car. It may be a diagonal brace-rod in a Pratt truss which runs counterwise with those rods which carry the load. It may then be between the bolsters.
- Body center-bearing truss.** Figs. 5038-9. See *Center-plate truss*.
- Body-cushion** (English). 186, figs. 501-3. See *India-rubber body-cushion*.
- Body end-rail.** See *End-rail*.
- Body end-furring** (street-cars). 148a, figs. 5654-8. *Furring* in the end of a car.
- Body end-plate.** J, figs. 514-15. A plate across the end of the car joining the side-plates together. They are frequently made very wide and heavy, as in the figure. See *End-plate*.
- Body-end rib** (street-car). A rib in the end of a street-car. See *Body-rib*.
- Body hand-rail.** 44, figs. 438, 444, 450, and 539. An iron rod or bar attached to the end of passenger and street-cars for persons to take hold of in getting on or off the cars; not to be confused with *Platform-rail*, which see.
- Body-knee** (English). 82, figs. 348-51. No American equivalent. A heavy wrought-iron knee, securing the sides of the body to the *under-frame*, and keeping them at right angles to one another.
- Body-post** (freight-car bodies). 42, figs. 229-66, 355-72; 54, figs. 570-74. An upright timber which is framed into the sill and plate of a freight-car. The body-posts and *corner-posts* form the vertical members of the side-frame of a car-body. In passenger-cars such posts are called *window-posts*, which see. See *Post*.
- Body-post-pocket.** 42', figs. 229-66, 355-72, etc. See *Pocket*.
- Body queen-post.** 22, figs. 435-73, and 570-83. An iron rod, bar, or casting, on the under side of a car-body and against which the *body truss-rods* bear. It is often stiffened laterally and longitudinally by a *body queen-post stay*. See also *Queen-post*.
- Body queen-post stay.** 22a, figs. 450, 540-1. See *Body queen-post*.
- Body-rib or side-stud** (street-car). 33, figs. 5654-67. A rib of car-body framing, which corresponds to the studs of a steam-car car-body. They are curved to conform to the shape of the street-car car-body.
- Body roller-plate.** 17, figs. 332-5. A bearing-plate for the center truck of a 12-wheel car; corresponds to the center-plate and side bearings of the end truck. The rollers move transversely to the car when the car passes upon and over a curved track.
- Body side-bearings.** 16, figs. 229-66; 14, figs. 435-73; 9, figs. 1428-57. The upper one of the two *side-bearings*, which see, attached to the body-bolsters.
- Body side-bearing truss.** Figs. 5052-3. See *Side-bearing bridge*.
- Body-spring.** A *bolster-spring*, which see.
- Body-transom.** 22, figs. 229-66, 287-9; 26, 435-73; and 26, 539-41, etc. A name sometimes given to the *needle-beams* or *cross-frame tie-timber*, which see, bolted to the under side of the sills.
- Body truss-rod.** 19, figs. 229-66; 20, figs. 435-73, and 539-41. A long rod under a car-body to truss it, and prevent it from sagging in the center. This rod is continuous from end-sill to end-sill, in well-designed modern freight-cars, but sometimes it is attached to a *truss-rod anchor-iron* on or near to the body-bolster. In passenger-cars the use of the *truss-rod anchor-iron*, 24, figs. 435-73, is very common, although some roads use a continuous rod, as in figs. 435-8. The truss-rods are distinguished as *center* and *side* or *outside* body truss-rods. The center truss-rods are universally continuous from end-sill to end-sill. There are usually four truss-rods to a car, but sometimes only two in number. See also *Inverted body truss-rod*.
- Body truss-rod bearing.** 21, figs. 229-66. A cast or wrought iron plate or post on the under side of a truss-block or of a cross-frame tie-timber, serving the purpose of a *body queen-post*, which see. 22, figs. 435-73.
- Body truss-rod hopper-strap.** 19a, figs. 298-315. A tie-strap passing under and supporting the hopper of a gondola-car, the ends of which strap are fastened to the round *body truss-rods* which carry the stress to the end-sills, as shown in fig. 305.
- Body truss-rod saddle.** 20, figs. 229-66, etc.; 21, figs. 435-73, etc.; figs. 930-2. A block of wood or casting which forms a distance-piece on top of a bolster, and on which a continuous body truss-rod bears. Properly speaking, a *saddle* means a common bearing for a pair of rods with a central support, but it is not restricted to such use.
- Bogie** (English). A swiveling *car truck*, which see. All American eight-wheeled cars and coaches are what are termed in England *bogie carriages*, or *wagons*.
- Bogie carriage** (English). A vehicle for passenger service recently much used on the fastest trains. The body is from 40 to 54 feet long, divided into compartments, with side doors, and seating from 30 to 80 passengers. It is carried on four or six wheel trucks. See also *Carriage*.
- Bogus-plate** (refrigerator-cars). A horizontal timber attached to the posts on the inside of the car, a short distance below the plate. The *bogus-plates* support hori-

zontal cross-timbers called *meat-timbers* or *hanging-bars*, to which hooks are attached for hanging meat.

Boies car-wheels. Figs. 5282-91. A steel-tired wheel with a wrought-iron single plate or with a double plate center. The single plate seems most in favor and is fastened by what the manufacturers call an integral tire lock. This lock and the manner of fastening the tire are shown in the engravings, with the cross section of the tire, fig. 5289.

Boiler wagon (English). A six or eight wheeled car having two bogies or trucks at the ends with a drop-down platform between them, adapted to carry any exceptionally heavy or bulky load, such as a boiler, a heavy piece of machinery or a portable engine. It is mechanically an American freight car with the middle portion dropped down to near the level of the rails.

Bolster. Figs. 1433-5, etc. A cross timber or trussed beam on the under side of a car-body (*body-bolster*, which see), and in the center of a truck (*truck-bolster*, which see). The bolsters carry the body and truck *center-plates*, the body-bolster resting on the truck-bolster. Special forms for passenger cars are *Compound-bolster*, *Iron body-bolster*, *Double iron-body-bolster*, which see. Figs. 1428-57.

Truck-bolsters are either *swing-bolsters*, which see, admitting of lateral motion to ease off shocks, or *rigid bolsters*, which permit no lateral motion. All passenger trucks have swing-bolsters. In freight-car service the rigid bolster is gaining the preference, and rigid-bolster trucks are the more numerous. See *American steel* and *Schoen*.

Bolster-bridge (six-wheel truck). 62, figs. 4957-66. A *Side-bearing bridge*, which see.

Bolster center-casting. 12c fig. 281. A hollow rectangular shaped casting placed between the draft-timbers and body-bolster plates; the king-bolt passes through it.

Bolster distance-block. 3 and 4, figs. 1428-57. The same as a *body-bolster thimble*.

Bolster fitch-plate. 12A, figs. 287-8. The iron or steel plates of a built-bolster sandwiched between wood pieces.

They are much in favor for *body-bolsters* and *truck-bolsters* and are placed on edge so as to resist bending.

They are also called *bolster sandwich-plates*.

Shown in figs. 899, 1429.

Bolster I-beam separator-casting. Figs. 4685-7.

Bolster jack-screws (wrecking cars). Jack-screws attached to the spring-plank for the purpose of taking the load off the springs and making the entire truck and car body one rigid structure when the derrick of the wrecking-car is in use. *Tongs* or *crabs*, which see, and detached jack-screws are used to accomplish the same end, as figs. 207, 389-96.

Bolster-plates (passenger-car trucks). Wrought-iron plates bolted to the sides of wooden body-bolsters to strengthen them.

Bolster sandwich-plate. See above.

Bolster-springs. 80, figs. 4580-4966, and 5192-5234. The main springs of a car, carried on the *spring plank* and supporting the *truck-bolster* on which the weight of the car-body rests.

Bolster-spring cap. 75, figs. 4580-4966. See *Spring-plate*.

Bolster-spring seat. 74, figs. 4580-4966. See *Spring-plate*.

Bolster truss-block. A timber serving as a distance-piece to fill a vacant space between the *bolster* and the *center-plate*. There are two: a *body-bolster truss-block* and a *truck-bolster truss-block*, which see.

Bolster truss-rod. See *Body-bolster truss-rod*, *Truck-bolster truss-rod*.

Bolster truss-rod washer. See *Body-bolster truss-rod washer*, *Truck-bolster truss-rod washer*.

Bolt. 1. A pin, rod, or bar of metal used to hold or fasten anything in its place; ordinarily a *bolt* has a head on one

end and a screw and nut on the other, while a *rod* has a nut on both ends, as shown in figs. 3703-20, etc.

Various forms of bolts, which see for further definition, are as follows:

<i>Carriage-bolt.</i>	<i>Key-bolt.</i>
<i>Eye-bolt.</i>	<i>Lug-bolt.</i>
<i>Jaw-bolt.</i>	<i>Machine-bolt.</i>
<i>Joint-bolt.</i>	<i>Strap-bolt,</i> or
	U-shaped bolt.

For bolts whose names are derived from the purpose for which they serve, see:

<i>Box-bolt.</i>	<i>Journal-box-cover</i>
<i>Brake safety-chain</i>	<i>bolt.</i>
<i>bolt.</i>	<i>King-bolt</i> (or center-
<i>Column-bolt.</i>	<i>pin).</i>
<i>Discharge-valve stop-</i>	<i>Piston-follower bolt.</i>
<i>bolt.</i>	<i>Reversing-valve plate</i>
<i>Draft-bolt</i> (Janney).	<i>bolt.</i>
<i>Drawbar-bolt.</i>	<i>Stake-pocket U-bolt.</i>
<i>Hub-bolt.</i>	<i>Stop-bolt.</i>
<i>Journal-box bolt.</i>	<i>Tire-bolt.</i>

2. (Locks and latches.) A bar which enters the keeper or strike-plate and effects the lock. Figs. 2535 *et seq.*

See <i>Berth-latch bolt.</i>	<i>Door-sash bolt.</i>
<i>Cupboard-bolt.</i>	<i>Door-sash-lock bolt.</i>
<i>Door-latch bolt.</i>	<i>Seat-lock bolt.</i>
<i>Door-lock bolt.</i>	<i>Sofa-bolt.</i>

3. Figs. 2535, etc. A *door-bolt*, which see, moved in slides directly by the hand to fasten an opening. See also:

<i>Barrel door-bolt.</i>	<i>Headboard bolt.</i>
<i>Flush-bolt.</i>	<i>Window-blind bolt.</i>

Bolt-stop (Seat-lock). Figs. 4029-33. A small pin passing through the bolt to check excessive withdrawal.

Bonnet (passenger-cars). A *platform-hood*, which see.

Books, catalogues, pamphlets, etc. (M. C. B. Standard sizes). See *M. C. B. reports*.

Boom (of a derrick or crane). 1, figs. 391-6. Also called *job*. The main inclined compression member carrying the hoisting gear and abutting at its foot against a *boom-shoe* or directly against the mast. Its upper end is supported by stay-rods or tension-rods which, in a crane, are of fixed length, and, in a derrick, of varying length, capable of adjustment. See *Derrick*.

Boom-cap clevis (of a derrick or crane). Figs. 391-6. A clevis, which see, sometimes attached to the upper end of the boom, to which the fixed end of the *hoisting-ropes* is attached. In other cases, the clevis for this purpose is carried on the hoisting-block.

Boom-sheave (of a derrick or crane). Figs. 391-6. A sheave carried at the upper extremity of the boom over which the hoisting-chain passes.

Boom-shoe (of a derrick or crane). Figs. 392-3. A casting carried at the foot of the mast and constructed so as to be able to revolve against the boom base. It is supported by *boom shoe-rods*.

Boom-shoe rods (of a derrick or crane). 16, figs. 329-3. Rods attached to the *head-block* or cap at the top of the mast and supporting the boom-shoe.

Boom-shoe rollers (of a derrick or crane). Rollers at the foot of the mast upon which the boom-shoe revolves.

Bosley weather-strips. Figs. 2819-24, 4534-9. See *Weather-strips*.

Boss, or hub (of a steel-tired wheel). Figs. 5255-5331. The central portion through which the axle passes. *Boss* is the usual English term, but little used in the United States.

Boston-finish flush door-bolt. Fig. 2545.

Bottle-breaking head (Babcock fire extinguisher, which see). Fig. 3704. It breaks the acid-bottle by screw-pressure.

Bottom. "The lowest part of anything; as the bottom of a well, vat, or ship."—*Webster*.

See <i>Alcove-bottom.</i>	<i>Hopper-bottom.</i>
<i>Candle-lamp bottom.</i>	<i>Lamp-bottom.</i>
<i>Drop-bottom.</i>	<i>Seat-bottom.</i>
<i>Extreme-bottom.</i>	<i>Slide-bottom.</i>
<i>Fire-proof bottom.</i>	<i>Water-bottom.</i>

Bottom-arch bar. 15, figs. 4576-4805. An *inverted arch-bar*. The *pedestal tie-bar* is sometimes called bottom arch-bar. See *Arch-bar*.

Bottom cap (engineer's valve). 35, figs. 1710-15. Another term for a *lower cap* of a valve.

Bottom-case (engineer's valve, etc.). 33, figs. 1710-15. Another term for a *lower-case* of a valve.

Bottom-chord (of trusses). See *Lower-chord*. Neither term is regularly used to designate any part of car-trusses, but the *side-sills* are bottom-chords in trussed side-frames.

Bottom cross-piece (English). 93, figs. 501-4. The transverse piece in the *under-framing*, which see, supporting the floor and partition. Also called *bottom cross-bar*.

Bottom cylinder-head (Westinghouse driving-wheel brake). 4, fig. 1747. A circular cast-iron cover for the lower end of the cylinder. The piston-rod works through it.

Bottom door-panel (English). 128, fig. 504. The lowest panel on the outside of the door of a carriage.

Bottom door-rail. 5, figs. 1783-93. The lower transverse piece of a *Door-frame*, which see.

Bottom door-track. 66, figs. 229-66, 355-72 and figs. 1795 and 1823. A door-track below a sliding-door. Usually a metal bar. Sliding-doors are often provided with rollers or slides which rest on the track. Freight-car doors usually slide on a *top door-rack*, which see. See also *Door-hanger* and *Car-door hanger*.

Bottom end-piece (English). 92, figs. 501-2. American equivalent, *end-sill*. The transverse end-piece in the under-frame of a passenger vehicle.

Bottom face-plate guide. (Gould vestibule.) 43, figs. 2431-6. See *Gould vestibule*.

Bottom light-rail (English). 102, figs. 501-3. A part of the body framing of a carriage, forming the bottom of the window opening.

Bottom panel-batten (English). 105, fig. 501. American equivalent, *furring*. In a carriage, a part of the body framing used to stiffen the *panel*, which is pinned to it. See *Bottom-side panel*.

Bottom-plate (iron body-holster). 2, figs. 1428-57. See *Body-bolster*.

Bottom-rail. 1. (Of a sash or door.) 147, figs. 444, 540; 5, figs. 1783-93. The lowermost horizontal bar or member of a frame. 2. (Of pipe-box.) 226, fig. 554.

Bottom-side (English). 91, figs. 501-4. The lower longitudinal framing of the body of a passenger vehicle.

Bottom side-and-end knee (English). 144, fig. 502. A wrought-iron knee joining together the side and end members of the bottom of the body framing of a carriage.

Bottom side-panel (English). 123, fig. 501. The lower panel on the outside of the body of a carriage.

Bottom stove-plate (Baker heater). Figs. 2913, etc. See *Ash-pit bottom*.

Bottom stove-plate (Spear heater). A circular casting which rests on the floor of a car.

Boudoir (bood'-warr, Fr.). A luxurious private parlor for a lady. Hence—

Boudoir sleeping-car. Figs. 205, 2418. See *Mann boudoir sleeping-car*.

Bow. See *Platform-hood bow*.

Bowl. 2, fig. 3468, etc. See *Basin*.

Bowl (Pintsch gas-lighting). 100, fig. 3200. A clear glass bowl used on all center and vestibule lamps.

Box. See *Journal-box*. 3, fig. 4580; and figs. 4758-60, 5133-75. *Wheel-box* (street-cars).

Box-bolt (diamond trucks). 108, figs. 4581, 4669, and 4740. The bolts holding the *journal-box* in place. More properly, *journal-box bolts*.

Box-car. Figs. 1-14, 55-61, 229-66; details, 617-915. The most common form of American freight-car, with roof and sides inclosed, to protect its contents. They are mounted upon two four-wheel trucks, and rarely built

with four wheels nowadays. The present tendency is to continually increase their length and capacity. They are usually lined for half their height with *inside lining*, and provided with an interior grain-tight *grain-door*. See *Car*. *Freight car*.

Box-car details. Figs. 617-902.

Box-cover. See *Journal-box cover*.

Box-cushion. Figs. 3906, 3929-38, 3956-67, etc. A cushion for passenger-car seats made on a wooden frame. In distinction from a *squab-cushion*, now little used, which is a loose pad on the seat. Box-cushions are sometimes stuffed with hair or other elastic material alone, but usually steel springs are used in addition.

Box-guide. See *Journal-box guide*. *Pedestal*.

Box-lid. 4, figs. 4576-4805; and figs. 5167-75. See *Journal-box cover*. *Davis, Drexel, Fletcher, Hewett, Morris, and Schoen journal-box lid*.

Box-packing. *Journal-packing*, which see.

Box-room (on axle). The *dust-guard seat*, which see.

Box-steps. 45, 46, 48, figs. 444-50; and figs. 2419-45.

Passenger-car steps made with wooden stringers or sides. They are to be distinguished from the open steps shown in fig. 583. Ordinarily called the *platform steps*.

Box stock-car. An ordinary box-car with large grated openings for ventilation, but excluding rain. Little used except for horses. See *Stock-car*.

Box fruit-car. Figs. 5, 6, 7. See *Ventilated box-car*.

Box-hopper bottom. Figs. 305-9. A hopper of a *gondola-car* with inclined floors running longitudinally with the car, but with the sides of the hopper straight; and sometimes straight with the side-sills of the car. To distinguish it from the *pyramidal-hopper bottom*, whose floors are inclined both on the sides and ends as in figs. 310-15.

Brace. 33, figs. 229-66; 165, fig. 456. An inclined beam, rod, or bar of a frame, truss, girder, etc., which unites two or more of the points where other members of the structure are connected together, and which prevents them from turning about their joints. A brace thus makes the structure incapable of altering its form from this cause, and it also distributes or transmits part of the strain at one or more of the joints toward the point or points of support, or resistance to that strain. A brace may be subjected to either a strain of compression or tension. In the former case, in car construction, it is called simply a *brace*; in the latter it is called a *brace-rod*.

They are called *right* or *left-handed*, according to the inclination of their top to a person standing facing the car.

See <i>Berth-brace,</i>	<i>Corner-post brace.</i>
<i>Body-brace.</i>	<i>Door-brace.</i>
<i>Brake-lever bracket</i>	<i>End body-brace.</i>
<i>brace.</i>	<i>Floor-timber brace.</i>
<i>Brake-shaft brace.</i>	<i>Pedestal-brace.</i>
<i>Brake-shaft step</i>	<i>Roof-brace.</i>
<i>brace.</i>	<i>Seat-bracket brace.</i>
<i>Compression-beam</i>	<i>Side-lamp brace.</i>
<i>brace.</i>	<i>Stop-brace.</i>

Brace-block. E, fig. 5660.

Brace-pocket. 39 and 41, figs. 229-66, 355-72, and figs. 696-710. A casting which forms a socket for holding the ends of braces, especially of car-bodies. See *Brace*, also *Double-brace pocket*.

Brace-rod. 34, figs. 229-66, 355-72; 51A, fig. 574. An *inclined* iron rod which acts as a *brace*. A vertical rod acting in conjunction with a brace is called a *sill-and-plate rod*, or, in passenger-cars, for short rods below the window, *brace straining-rod*. See *Body-brace rod*. *Counterbrace-rod*. *Propelling-lever brace-rod*.

Brace-rod, straining-rod. 53, figs. 435-73. It should read *brace straining-rod*.

Brace-rod washer. 38, figs. 229-66; 57, figs. 435-73. A bearing-plate for the nut or head of a brace-rod, sometimes made a *triangular* or *beveled* shape, which see, and sometimes a flat bar of iron, bent to fit into a *notch* cut in the timber.

Brace straining-rod (passenger-car framing). 53, figs. 449-52, etc. A vertical iron rod in the side or end frame of a car-body by which the upper end of a brace is connected or tied to the sill of the car. The brace-rods are members of the truss, of which the sill, braces, posts or plates, etc., form parts. Such rods often have hook-heads at the upper ends against which the braces bear, and nuts at the lower ends by which they are screwed up, and are thus brought into a state of tension and the braces into compression. An equivalent in freight service is the *sill-and-plate rod*.

Bracket. 1. "An angular stay in the form of a knee to support shelves and the like."—*Webster*.

See <i>Arm-rest bracket.</i>	<i>Lamp bracket.</i>
<i>Basket-rack bracket.</i>	<i>Lamp-chimney bracket.</i>
<i>Bell-cord strap-hanger bracket.</i>	<i>Longitudinal-step bracket.</i>
<i>Berth bracket.</i>	<i>Post-bracket.</i>
<i>Berth-corner bracket.</i>	<i>Release-spring bracket.</i>
<i>Berth-curtain-rod-bracket.</i>	<i>Running-board bracket.</i>
<i>Brake-lever bracket.</i>	<i>Scheme-rod bracket.</i>
<i>Brake-shaft bracket.</i>	<i>Seat-bracket.</i>
<i>Brake-step bracket.</i>	<i>Seat-rail bracket.</i>
<i>Coupling-spring bracket.</i>	<i>Side-lamp bracket.</i>
<i>Cylinder-lever bracket.</i>	<i>Signal-light bracket.</i>
<i>Door-track bracket.</i>	<i>Sliding-door bracket.</i>
<i>Hand-rail bracket.</i>	<i>Smoke-bell bracket.</i>
<i>Inside-hand-rail bracket.</i>	<i>Tender-spring bracket.</i>
	<i>Towel-bracket.</i>
	<i>Window-curtain bracket.</i>

2. (Iron framing for bridges or cars.) An L-shaped angle-plate riveted to each of two members which it is desired to connect at right-angles to each other as an *end-sill bracket*, or *Sill knee-iron*, 8, figs. 451, 517. A stronger form, little used in car construction, is called a *triangular gusset-plate*, which see.

Bracket (of cast-iron wheels). Figs. 5336-38. The stiffening ribs cast on the plate.

Bracket berth-hinge (emigrant sleeping-berths). A, figs. 2413-14. A berth-hinge with a shoulder to directly support the inner edge of the berth without relying on the hinge-pin.

Bracket gas-burner. A gas-burner attached to the side of a car.

Bracket lamp. Figs. 3288-3304. A *side-lamp*, which see. See *Pintsch gas-lamp* and *Frost lamps*.

Bracket-nut. A small *spanner-nut*, which see.

Brake, or brake-gear. Figs. 1458-63. The whole combination of parts by which the motion of a car is retarded or arrested. Passenger-car brakes are now almost exclusively *atmospheric*, being either *air-brakes*, operating by compressed air, or *vacuum-brakes*, operating by creating a vacuum. Of the former the most important by far is the *Westinghouse*, although the *New York* is in limited use. The air-brake is now almost exclusively used in its *automatic* form, and by the term *air-brake* the *automatic* brake is understood.

On freight-cars the *continuous* or *train* brakes have been introduced in large numbers. All new equipment of first-class cars is now supplied with automatic air-brakes. So far the Westinghouse Air-Brake Company has supplied the bulk of the equipment.

Of the many methods of combining brake-levers to apply brake-power, there are but a few in current favor. The Hodge system is used almost entirely on Passenger and Freight cars. The Elder and Stevens are rarely met on new equipment. They are shown in figs. 1458-63. The levers move the *brake-beams*, which carry the *brake-shoes* bearing against the wheels. The brake-beams are either *inner-hung*, figs. 4580-2, 4735-8, or *outer-hung*, figs. 1528-9 and 4740-6. Inner-hung brakes are also termed *compression-rod* brakes, the *brake-lever coupling-bar* or *Brake-lever strut* which unites them being in compression. *Driving-wheel* brakes, both steam and air, are in increasing use. See any of the words in italics for further information. See *Beamless brake*.

Brake (for drop-bottom car). Figs. 310-17. A brake arranged so that none of the rods or levers will interfere with the drop doors.

Brake-axle (hand-car). A shaft carrying an *S-brake shoe*, which see.

Brake-beam. Figs. 1504-5, 1546-1600; 84, figs. 4580-4966. Transverse iron, steel, or wooden bars to which the brake block and shoes are attached. They are either *inner-hung* or *outer-hung*, and often trussed, especially in passenger service. See *Trussed brake-beam*. *Detroit brake-beam*, figs. 1594-8. *Kewawee brake-beam*, figs. 1581-6. *Marden brakebeam*, fig. 1600. *National hollow brake-beam*, figs. 1546-60. *Universal brake-beam*, figs. 1599, 4862-71, 4899. *Westinghouse brake-beam*, figs. 1561-74.

Brake-beam adjusting-hanger. 122, figs. 4580-4966; 15, figs. 1528-9, etc. A link attached to a brake-beam so as to cause the latter and the brake head and shoe to maintain the same relative positions when the brakes are released, so as to prevent the ends of the brake-shoes from coming in contact with the wheel when the brakes are released. It is attached to the truck transoms or truck bolster in *freight trucks*, and to the truck-frame *end-piece* in *passenger trucks* by a projecting *brake-beam adjusting-hanger carrier*, and to the brake-beam by an eye or clip. Sometimes called a *Parallel brake-hanger*.

Brake-beam adjusting-hanger carrier. 121, figs. 4580-4966. See above.

Brake-beam adjusting-hanger eye or clip. 123, figs. 4580-4966. See above.

Brake-beam chafing-plate. A plate attached to a *brake-beam* against which a *brake-spring* bears, designed to resist the wear due to the action of the spring.

Brake-beam data. (M. C. B.) Fig. 5432.

Certain dimensions and capacities of brake-beam were adopted as standard of the Association, by letter ballot, in 1889, and these standards, as modified by subsequent action, are shown for iron brake-beams.

All beams must be capable of withstanding a load of 7,500 pounds at center without more than 1-16 inch deflection; where it is necessary to use a stronger beam, it must be capable of standing a load of 15,000 pounds at center without more than 1-16 inch deflection.

The angle of brake-beam lever is 40 degrees from vertical. Standard heights of brake-beams, when measured from the tops of the rails to the center of the face of new shoes, were adopted in 1894, as follows:

For inside hung beams, 13 inches.

For outside hung beams, 14½ inches.

Brake-beam eye-bolt. Properly an eye-bolt for fastening a *lower brake-rod* to a *brake-beam*. They have threads cut nearly their entire length, and usually a nut is placed on each side of the brake-beam, which can be screwed up so as to take up the wear of the brake-shoes. The term has been misapplied to the *brake-lever fulcrum* in figs. 4582, 4647, and 4740-1.

Brake-beam fulcrum. See *Brake-lever fulcrum*.

Brake-beam hanger (hand-car). 28, fig. 5595. A *brake-hanger*, which see.

Brake-beam king-post. A post or distance-piece, which forms a bearing for the truss-rods of a brake-beam. In metal brake-beams the brake-lever is attached to it and it then becomes a *brake-lever fulcrum* and is misnumbered 85 in figs. 4581-2, 4647.

Brake-beam release-spring. See *Release-spring*.

Brake-beam safety-chain. See *Brake safety-chain*.

Brake-beam safety-guard. See *Brake safety-chain*.

Brake-beam sleeve. Figs. 4862-3. A sleeve that fits the brake-beam in the middle and takes the swiveling *brake-beam king-post* of the *Universal brake-beam*.

Brake-beam strut. Figs. 1568-71. A *brake-beam king-post*.

- Brake-beam truss-rod.** Figs. 1546-1600. A rod used to truss or strengthen a brake-beam.
- Brake-block.** Figs. 1602-16f; 82 and 83, figs. 4576-4966. A piece of wood or metal which carries a removable *shoe* which bears directly against the tread of the wheel when the brake is applied. The brake-blocks are attached to the ends of a *brake-beam*. A *brake-head* is supposed to be a combined brake-block and shoe, but *brak-block* and *brake-head* are often used as equivalent terms.
2. ("American" driver-brakes). 17, fig. 1749.
 3. (English). 63, figs. 348-9. See *Wooden brake-block*, wood being the material of which they are composed.
 4. (Westinghouse driving-wheel brake). 17, fig. 1747.
- Brake-block pin** (Westinghouse driving-wheel brake). 26, fig. 1747. A pin by which the *suspending links* are attached to the brake-block.
- Brake-block pin-rod** (Driving-wheel brake). 27, fig. 1747. A tie-rod connecting the brake-shoes on opposite sides of the locomotive, to resist the tendency of the coned wheels to throw the brake-shoes outward.
- Brake-block safety-hanger** (Driving-wheel brake). 23a, fig. 1747.
- Brake-block suspending-link** (driving-wheel brakes). 23, figs. 1747-9. An iron bar attached to the *suspending-stud* at the top and to the *brake-block pin* at the bottom.
- Brake-block suspending-plates** (driving-wheel brakes). 24, figs. 1747-9. Wrought-iron plates bolted to the locomotive frame and carrying the *stud* furnishing a support to the upper end of the *brake-block suspending-link*.
- Break-block suspending-stud** (driving-wheel brake). 25, fig. 1747. See above.
- Brake-block tie-rod.** See *Brake-block pin-rod*.
- Brake-carrier.** See *Brake-hanger carrier*.
- Brake-chain.** See *Brake-shaft chain*.
- Brake-chain worm.** 1. 160, fig. 444. A conical casting attached to the brake-shaft with a screw-shaped groove for the brake-chain. Its object is to produce a rapid motion at first and increase the power when the brake-shoes are brought to a bearing.
2. 160, figs. 441-4; 17, fig. 2441. A cylindrical casting with a screw-shaped groove, intended only to make the chain wind evenly.
- Brake-clevis.** A *brake-lever fulcrum*, which see.
- Brake-connecting-rod.** More properly, *Brake-chain connecting-rod*.
- Brake cord-guide.** A guide similar to a bell-cord guide for the air-brake cord which passes through every car fitted with the Westinghouse automatic brake, and operates the *conductor's valve*, 22, figs. 1693-4.
- Brake cut-out cock.** 19, figs. 1693-8; fig. 1744.
- Brake cylinder** (Westinghouse automatic brake). 2, figs. 1693-8, and figs. 1726-31. A cast-iron cylinder attached to the frame of the car or locomotive, by which the brakes are operated. Upon passenger-cars and locomotives the brake-cylinder is fitted with two heads, while in the freight brake the auxiliary reservoir and brake-cylinder are cast in one piece. The cylinder contains a piston which is forced outwardly by the compressed air to apply the brakes, and is returned to its normal position, when the compressed air escapes, by a release-spring which is coiled about the piston-rod inside the cylinder. The piston-rod of the passenger-car cylinder (fig. 1727) has a crosshead upon its extremity, which is attached to the cylinder lever. The piston-rod of freight car cylinder (figs. 1728-9) and tender cylinder (fig. 1726) is hollow and loosely incloses a push-bar, which latter is attached to the cylinder lever. The piston of the driving-brake cylinder (fig. 1748) has a crosshead to which brake connections are attached. In the Eames vacuum-brake a *diaphragm* takes the place of the brake-cylinder.
3. (Westinghouse driving-wheel brake.) Fig. 1748. A cylinder attached to a locomotive in a vertical position between the driving-wheels. The force of the compressed air is transmitted to two levers, by a cam motion, which act against the *brake-heads* and thus apply the brakes. The main casting of the cylinder is called the *cylinder-body*.
- Brake-cylinder block** (Westinghouse freight-brake gear). Fig. 1697. A stick for attaching the combined cylinder and auxiliary reservoir to the under side of the sills. See *Auxiliary-reservoir beam*, a similar part for passenger-cars.
- Brake-cylinder pipe** (Westinghouse brake). 21, Figs. 1693-4. The pipe which connects the brake-cylinder with the triple-valve.
- Brake-cylinder plate** (Westinghouse freight-brake). The plate to which the brake-cylinder is bolted and by which it is attached to the sills.
- Brake-dog.** A *brake-pawl*, which see.
- Brake-drum.** A *brake-shaft drum*, which see.
- Brake-equalizer block, or center brake-lever block** (Elder brake). A block directly under the center of the car to which the brake-equalizing lever or center brake-lever (10, fig. 1462) is attached.
- Brake-equalizing lever** (Elder brake). 10, fig. 1462. More properly, *Center brake lever*, which see.
- Brake-equalizer strap.** A strap directly under the center of the car serving as a fulcrum for the *center brake-lever*.
- Brake-finger.** A *brake-pawl*, which see.
- Brake foot-board.** A *brake-step*, which see.
- Brake-gear** (Air) for Freight Cars (M. C. B. Standards). Figs. 5433-41. See *Air-brakes—general arrangements and details*.
- Brake-gear, Foundation** (M. C. B. Standard). Figs. 5442-83.
- Brake-gear.** (Rules for Interchange of Traffic.) The defects of brake-gear and parts for which cars may be rejected are as follows:
- (s) Brakes in bad order.
- Brakes shall be considered in bad order unless the following twenty-three conditions are complied with:*
1. Brake wheel secured to the shaft with properly fitted nut.
 2. Bottom of brake shaft secured by a nut or key or some other suitable device to prevent shaft lifting out of position.
 3. Brake chain secured to shaft with bolt, and bolt properly secured by nut or by rivet.
 4. Upper brake shaft bearing properly secured to the end and top of box and stock cars by either two bolts or one bolt and one lag screw not less than one-half inch in diameter
 5. Brake ratchet wheel sound and well secured to shaft.
 6. The brake pawl, when attached to brake step or to upper brake shaft bearing, secured with bolt and nut. When applied to roof of car, secured with either bolt or lag screw. The pawl sound and point effective.
 7. Brake steps secured by bolts in each of the two brackets. The brackets secured to car by either four bolts or four lag screws. The brake step sound at outer edges through both bolt holes.
 8. Brake shaft step secured to car by either two or four bolts or lag screws. When the drawbar carry irons form the step, two bolts passing through draft-timbers should be effective.
 9. Brake hangers secured to car body or trucks with full complement of bolts and nuts the hanger is drilled to receive, and also secured to brake head and beams in like manner. Brake-beams, levers, and attachments not less than 2½ inches from the top of the rail.
 10. Brake heads in a condition to hold the shoes in place when applied.
 11. Brake-shoes secured to brake head by either key bolt, bolt and nut, or key, as required by form of head.
 12. Brake-shoes ¾ inch thick or more at center.
 13. Brake wheels must be free from any defect.
 14. Brake-beams sound, and when hung to body provided with guide irons.
 15. Brake-beam fulcrums (cast-iron) sound, and secured to brake-beam by two bolts. Wrought-iron fulcrum firmly secured.
 16. Brake connections properly secured to brake-beam and to brake levers with key bolt and key.
 17. If the car has air-brakes, the cylinder and triple valve must have been cleaned and oiled within twelve months, and the date of the last cleaning and oiling marked on the brake cylinder.
 18. If the car has air-brakes, the brake-shoe slack must be so adjusted that under the full application of the brakes the piston travels not less than five inches nor more than nine inches.
 19. If the car has air-brakes, the brakes must apply and release promptly with proper handling by the engineer's valve.

20. Triple valves and auxiliary reservoirs must be free from water.

21. Air pipes and all connections thereto must be free from leaks, and the pipes properly secured to the car body so that injury shall not occur to the apparatus nor leaks be produced by shaking and vibration of the pipe.

22. If the car has air-brakes, it must have two hose and couplings, in good order, which must be properly secured in the dummy couplings when not coupled to other cars.

23. If the car has air-signal pipes or air-brake pipes, but no air-brakes, the hose and couplings on the car are at owners' risk, unless the car is stenciled that it is so equipped. See *Interchange of Traffic*.

Brake-handle. 216, fig. 5654. See *Brake-shaft crank*.

Brake hand-rail. 190, figs. 229-31, 258, 244-6, etc.; details, figs. 878-9. A hand-rail, on the roof of box and stock cars, usually made of gas-pipe, for the protection of brakemen when applying brakes. It is stiffened by a *hand-rail brace*. Master Car Builders' Recommended Practice with regard to the same is shown in figs. 5546-7.

Brake hand-wheel. 93, figs. 229-66. See *Brake-wheel*.

Brake-hanger. 86, figs. 4580-4966. A link or bar by which brake-beams and attachments are suspended from a truck-frame or car-body. It is attached to truck and car-body by a *brake-hanger carrier*. Brake-hangers are distinguished as *hooked*, *linked*, and *U-shaped*.

2 (English.) 61, fig. 348. A wrought-iron bar by which the brake-block is suspended. No brake-beam is used.

Brake-hanger bolt. A bolt which fastens the *brake-hanger* to the *brake-hanger carrier*.

Brake-hanger bracket (English). 62, figs. 348-9. American equivalent, *brake-hanger bearing*. A bearing for the brake-hanger, generally made of wrought iron.

Brake-hanger bearing. 87, figs. 4942-56, 4963-6. A casting which is held by a brake-hanger carrier, and which forms a bearing for a brake-hanger.

Brake-hanger carrier. 87, figs. 4580-4966. An eye or U-bolt, a casting or other fastening by which a brake-hanger is attached to the truck or body of a car. See also *Parallel brake-hanger carrier* and *Brake-beam adjusting-hanger carrier*.

Brake-hanger pin. Fig. 4670. A pin passing through the *brake-hanger carrier* and *brake-hanger*.

Brake-hanger timber. 6, fig. 233. A short traverse timber between the floor-timbers of a car-body, and which is framed into them, and to which the brake-hangers, which are hung from the body of a car, are attached.

Brake head. Figs. 1602-16f; 83, figs. 4586-4966. A piece of iron or wood attached to a brake-beam and which bears against the wheels, and combines both a brake-block and brake-shoe in one piece. The term is also commonly applied to *brake-blocks* which carry a detachable shoe. See *Christie, Collins*, etc.

Brake head and shoe. Figs. 5425-31. The brake head and shoe shown, known as the Christie brake head and shoe, were adopted as a standard of the Association, by letter ballot, in 1886 with the exception of some slight modification in details made since that date.

Brake-hose (air-brakes). 26, figs. 1693-8, and 1737-42. Flexible tubes made of India-rubber and canvas by which the cars are connected together and compressed air, which operates the brakes, conducted through the train. The hose is made with a *coupling* at each end of each car, so that they can readily be connected or disconnected. See *Armored brake hose*, 1668 a b c.

2. (Eames vacuum brake.) Figs. 1677-9. A coiled wire is used inside to prevent collapsing.

Brake-hose armor. See *Armored brake-hose*.

Brake-hose coupling (air-brake). Figs. 1740-1. A contrivance for coupling or connecting the ends of a pair of brake-hose together, so that the air by which the

brakes are operated can pass from one vehicle in a train to another. The couplings for train-signal apparatus are made with thicker lips than brake-hose couplings, though otherwise similar, to avoid danger of wrong connections.

2. (Eames vacuum brake.) Figs. 1684-7. Accomplishes the same result as the Westinghouse coupling, in a somewhat different manner.

Brake-hose coupling-case (air-brake). Figs. 1740-1. A hollow casting which joins the main part of a coupling to which the hose is attached.

Brake-hose nipple (air-brake). Fig. 1739. A tubular elbow connecting the coupling-hose and the brake-pipe.

Brake-lever. 92, figs. 4580-4966; 5, fig. 1535; details, 4598-4601, 5122-5, etc. A lever by which the power employed to apply the brakes is transmitted to the *brake-beams*. The brake-levers are connected to the brake-beams at or near the short ends of the former, and the *brake-shaft connecting-rod*, or some equivalent part, to the other end.

When only one brake-lever to a truck is used, the pressure of the two brake-beams is unequal. To obviate this two brake-levers are used, as shown in figs. 4580-4966, which are further distinguished as *dead-lever* and *live-lever*. The upper end of the *dead-levers* is then attached to a *brake-lever stop* or *dead-lever guide*. *Dead-levers* are also called *fixed brake-levers*. See *Centre-brake-lever*. *Floating-lever*.

2. (English.) 57, figs. 348-51. A long bar attached to the *brake-shaft* in order to apply the brake by hand. See *Guard's van*.

Brake-lever bracket (hopper-bottom coal cars). A wrought-iron knee on the under side of a car, to which the fulcrum of a brake-lever is attached.

Brake-lever-bracket brace. A diagonal wrought-iron brace, to stiffen the brake-lever bracket.

Brake-lever clevis. A *Brake-lever fulcrum*, which see.

Brake-lever coupling-bar (inner-hung brakes). 93, figs. 4575, 4580-2, and figs. 4593-4. A compression-bar connecting the two brake-levers (*dead-lever* and *live-lever*), to which it is fastened by the *coupling-bar pin*. When the brakes are outer-hung, this member becomes in tension instead of compression and is known as the *lower brake-rod*. It is called a *Brake strut*.

Brake-lever fulcrum. 85, figs. 4580-2, 4647, 4740-1; 93, figs. 4751, 4952, and 4955-66. A forked iron attached to a *brake-beam* by means of which a *brake-lever* is connected to the beam. It is usually a *jaw-bolt*, figs. 4740-1. In some cases a casting is used, *brake-lever jaw*. In the trussed iron brake-beam the *king-post* of the brake-beam becomes the brake-lever fulcrum. In the list of names with figs. 4560-75, 85 should be called a *brake-lever fulcrum*, which it designates in the figures. See *Brake-beam king-post*.

Brake-lever guard (English). 58, figs. 348-51. No American equivalent. A curved wrought-iron bar which confines the movement of the brake-lever within proper limits. See also *Brake-lever ratchet*.

Brake-lever guide. 94, figs. 4580-4966; details, figs. 4591-2 and 5067-9. An iron bar which guides the upper end of a brake-lever. Further distinguished as *live-lever* and *dead-lever* guides, the latter provided with pins for readjustment as the brake-shoes wear, and also called a *brake-lever stop*.

Brake-lever handle (English). 60, figs. 348-51. The handle at the end of the brake-lever.

Brake-lever hanger-bridge. 17, figs. 1540-2. A wrought-iron bar borne by the iron transom of a six-wheeled truck, and carrying the *brake-lever connecting-rod*, 4, and the *live-lever*, 3, by the hanger, 5.

Brake-lever jaw. A *brake-lever fulcrum*, which see.

Brake-lever ratchet (English). 59, figs. 348-51. Teeth cut in the *brake-lever guard* (which see), to prevent the brake coming off after being applied.

Brake-lever sheave (Elder brake-gear). Figs. 963, 976, and 1462. A pulley attached to a brake-lever, over which a chain by which the brakes are applied runs.

Brake-lever stop. 95, figs. 4581, 4644, 4942-6, and figs. 4591, 4727, 4782. An iron bar or loop attached to a truck or car frame, and which holds the upper end of a fixed or *dead* brake-lever. It usually has holes in it in which a fulcrum pin is inserted. By moving the pin from one hole to another the lever is adjusted so as to take up the wear of the brake-shoes. Also called *Dead-lever guide*.

Brake-lever strut. A *brake-lever coupling-bar*.

Brake-mast. A *brake-shaft*, which see. 94, figs. 229, etc.

Brake-pawl. 103, figs. 229, etc., and figs. 770, 940, and 1137. A small pivoted bar for engaging in the teeth of a *brake ratchet-wheel*, which see. It is placed in such a position as to be worked by the foot.

Brake-pawl carrier. Fig. 900. See *Brake-pawl* and *Brake ratchet-wheel*.

Brake-pawl dog. A pivoted casting serving as a weight to throw up the *brake-pawl* so as to engage with the ratchet when the ratchet is on the under side of the *brake ratchet-wheel*. Also applied to an eccentric which holds a pawl against a ratchet-wheel.

Brake-pin. Fig. 4671. A pin used in the *brake-lever coupling-bar* and other connections.

Brake-pipe (Air-brake). 16, figs. 1693-8. An iron pipe extending from one end of the car to the other under the car-body, and connected to the pipes on the adjoining cars by flexible *brake-hose*, serving to convey the air from the air-pump on the engine to the *auxiliary reservoirs* attached to the cars. These pipes are filled with compressed air when the brakes are not on. When the latter are to be applied, the air is allowed to escape from the pipes, which causes the *triple-valves* to open communication between the *auxiliary reservoirs* and the *brake cylinders*, so that the compressed air stored up in the reservoirs acts on the pistons and brake-levers. The popular term for this pipe is a *train-pipe*, or more properly a *train brake-pipe*, to distinguish it from the *train signal-pipe* or *steam-heating pipes*.

Brake-ratchet gear, complete. Includes the ratchet-wheel, the pawl, the dog, the carrier.

Brake ratchet-wheel. 103, figs. 229, etc. A wheel attached to a brake-shaft, having teeth shaped like saw-teeth, into which a *pawl* engages, thus preventing the wheel and shaft from turning backward. In some forms the ratchet wheel has the ratchet upon the under side, instead of on the edge; the brake-pawl being automatically pressed upward against the teeth by a counterweight called a *brake-pawl dog* and without being adjusted by the foot of the brakeman. Such a ratchet-wheel is minutely shown, 103, figs. 244-6, and in figs. 714-17 and 769. The brake-pawl is pivoted in the *brake-pawl carrier*, fig. 900, which latter is bolted to the roof of the car.

In 1879 the M. C. B. Convention recommended that the practice of placing the ratchet-gear on a small platform or *brake-step* be discontinued, and that they be fastened to a suitable casting on the roof. Their recommendation has not been universally adopted, though it is a very common practice.

[In most of the standard English dictionaries, as well as in Knight's "American Mechanical Dictionary," the term ratchet is defined as the dog or pawl which catches into the ratchet-wheel, as well as the ratchet-wheel itself. The same dictionaries, however, also give *pawl* as the name for the part serving this purpose, and it is believed that this is an error in definition, at least as respects American practice, which has been copied from one dictionary to another, and which does not correspond with the practice in mechanical work, in which the term "ratchet" is confined to the serrated edge, whether straight or on a wheel, into which the pawl engages, and does not designate the pawl itself as a ratchet.]

Brake-rod. Any rod serving to connect brake-levers, but especially the *lower brake-rod*, 97, figs. 4576-4966, which see, and the *secondary brake-rod*, which see. The *brake-shaft connecting-rod* is sometimes called the *main brake-*

rod. The *long brake-rod* extends the entire length of the car in the Stevens brake-gear.

See *Lower brake-rod*. *Secondary brake-rod*.
Main brake-rod.

2. (English.) 53, figs. 348-51. A bar of iron connecting the *brake-shaft arms* to the brake-blocks.

Brake-rod guide. Any form of special support for a brake-rod.

Brake-rubber. A *brake-shoe*, which see.

Brake safety-chain, or link. 88, figs. 4580, 4966; fig. 4659; 9, figs. 1528-9; and 13, figs. 1540-2. A chain attached by *brake safety-chain eye-bolts* to a brake-beam and to the truck or body of a car. It is intended for the same purpose as a *brake safety-strap*, or a brake-beam safety hanger, which see, to hold the brake-beams in case a brake-hanger should break. Sometimes made of a single link or bar. A *brake-beam safety-guard* is not bolted or fastened to the brake-beam, but is usually a J-shaped forging, the stem being bolted to the truck frame, the cross-bar hanging under the brake-beam to prevent it falling upon the track if the *hanger* break. See 13, figs. 1540-2, and figs. 4580-2, 4942-6.

Brake safety-chain eye-bolt. 89, figs. 4580-4966. An eye-bolt attached to a truck or car-body, and which holds a brake safety-chain.

Brake safety-strap. 90, figs. 4593, 4963-6, and figs. 4897, 5130. A strap of iron fastened to the end-piece or transom of a truck and bent into such a shape as to embrace the brake-beam. In case any of the hangers should give way, the safety-strap is intended to catch and hold the beam and prevent it from falling on the track. Sometimes it is made of steel, and used as a brake-spring for throwing off the brake. A *brake safety-chain*, which see, is another device for the same purpose.

Brake-shaft. 94, figs. 229, etc.; 152, figs. 435, etc. A vertical shaft on which a chain is wound and by which the power of a hand-brake is applied to the wheels. It is sometimes made *horizontal* and so called, as 95, figs. 232-4, etc. In box and stock cars it extends above the roof and is called a *long brake-shaft*.

The M. C. B. Association (1879) recommended "that all brake-shafts be placed on the left-hand corner of the car when a person is standing on the track facing the end of the car, as in figs. 49 and 288. See *Horizontal brake-shaft*. •*Long brake-shaft*."

2. (English.) 53, figs. 348-51. A horizontal shaft to which are attached *brake-shaft arms*, which actuate the brake-blocks. A long lever is attached to it, provided with a handle by which the brakes can be applied.

Brake-shaft (M. C. B. position and dimensions). Figs. 5546-7.

In 1893 the following recommended practice was adopted to protect trainmen from accident, under the sub-heads as given. The brake-shaft to be placed on what is the left-hand corner of the car when a person is standing on the track facing the end of the car; the ratchet-wheel and brake-pawl to be fastened to a suitable casting attached to the roof; a railing or guard to be attached to the end and the roof of the car around the brake-shaft, the center of the brake-shaft to be 20 ins. from the middle of the car; the nuts on the ends of the brake-shafts to be secured by split spring cotters.

Brake-shaft arm (English). 55, figs. 348-51. See above.

Brake-shaft bearing. A metal eye by which a brake-shaft is held in its place, and in which it turns. See *Brake-shaft step*. *Lower brake-shaft bearing*. *Upper brake-shaft bearing*.

Brake-shaft brace (Miller coupler and platform). 1, fig. 2292. A brace which holds the bottom of the brake-shaft and forms a step for it.

Brake-shaft bracket. 99, figs. 232-4. A support for holding a horizontal brake-shaft in its place.

Brake-shaft bushing (Miller coupler and platform). Figs. 2290-2. A thimble on the brake-shaft.

Brake-shaft chain. 150, figs. 229, etc.; 3, figs. 1458-63. A chain connecting the *brake-shaft* with the *brake-levers* through the *brake-shaft connecting-rods*, to the end of which it is attached. The force exerted on the shaft is transmitted by this chain. See *Horizontal brake-shaft chain*.

Brake-shaft-chain sheave. 1. (Elder brake-gear.) Fig. 1462; 105, fig. 234. A roller over which a brake-shaft chain passes.

2. A sheave attached to the end sill for the chain of a horizontal brake-shaft to work in, 105, figs. 232-43.

Brake-shaft connecting-rod. 151, figs. 229, etc.; 4, figs. 1458-63. A rod which is attached at one end to a *brake-chain*, and at the other to a *brake-lever*, or to the *center-lever* of the Elder brake, or to the *floating-lever* of the Hodge brake.

Brake-shaft crank (street-cars). 216, fig. 5654. An elbow attached to the upper end of the brake-shaft, carrying a handle for turning the brake-shaft and operating the brakes.

Brake-shaft crank-handle (street-cars). Called also a *brake-shaft crank* or a *brake-handle*. See above.

Brake-shaft cross-bearer (English). 7, figs. 349, 351. A piece of timber secured to the *under-frame* and carrying a wrought-iron bracket in which the *brake-shaft* works.

Brake-shaft drum. The part of a brake-shaft on which the brake-chain is wound. See *Brake-chain worm*.

Brake-shaft gear-wheel. 16, figs. 2441-5. A bevel gear-wheel attached to the *brake-shaft* by which the power applied to the *brake hand-wheel* is conveyed to a *horizontal winding shaft* or *worm*, 17, fig. 2441, called a *Brake-chain guide-casting*.

Brake-shaft hanger (English). 54, figs. 348-51. A bracket by which the *brake-shaft* is carried and in which it is free to revolve.

Brake-shaft holder. A *Brake-shaft bearing*, which see.

Brake-shaft stand (Janney). A *Brake-shaft step*, which see.

Brake-shaft step. 100, figs. 229-66, etc.; figs. 435-73. A bearing which holds the lower end of a brake-shaft. It usually consists of a U-shaped bar of iron, the upper ends of which are fastened to the car-body, with a hole in the curved part of the bar which receives the end of the shaft. The *brake-shaft step* should not be confounded with a *brake-step*, which latter is a shelf on which the brakeman may step when applying brakes.

Brake-shaft-step brace. A wrought-iron brace to resist the pull of the brake-chain.

Brake-shaft thimble. An iron bushing attached to some part of the car to form a bearing for a brake-shaft.

Brake-shoe. 1. Figs. 1633-60. 98, figs. 4580, 4966. A piece of metal shaped to fit the tread of a car-wheel and attached by a key or otherwise to a *brake-block* or *brake-head*. The latter term, however, is more properly a combined brake-shoe and brake-block in one solid casting. The brake-shoe rubs against the tread of the wheel when the brakes are applied. Such shoes are made of cast, wrought, or malleable iron or steel, usually cast iron. The *Congdon brake-shoe*, fig. 1656-7, is of cast-iron, with sections of wrought iron or steel, cast in it, greatly increasing its durability, and, it is claimed, improving its holding power. English brake-shoes (*brake-blocks*), 63, fig. 348, are sometimes of wood, but metal shoes are coming into use.

<i>Christie brake-shoe.</i>	<i>Reversible-hook brake-shoe.</i>
<i>Lappin brake-shoe.</i>	<i>Ross brake-shoe.</i>
<i>Meehan-Sheppard shoe-brake.</i>	<i>Ross-Meehan brake-shoe.</i>
	<i>Schoen brake-shoe.</i>

2. (Westinghouse driving-wheel brake.) 16, fig. 1747.

Brake shoe-hanger ("American" bell-crank driver-brake). 23, fig. 1749. In the Westinghouse brake called the *suspending link*.

Brake-shoe holder (Driving wheel brake). A *brake-head* to which the *shoe* is fastened.

Brake-shoe key. Fig. 1637 and 5431. A key or wedge by which a *brake-shoe* is fastened to a *brake-block*.

Brake-slack adjusters. Figs. 1761-82. A device to automatically take up any slack in the brake-gear between the *air-brake cylinder* and the *brake-shoes*, so that the piston travel shall not be too great. It is applied to the *cylinder-lever tie-rod*, figs. 1761-8, to the *brake-cylinder piston-rod*, fig. 1770, or to the *truck brake-lever connecting-rod*, fig. 1776-7. There are several made and those illustrated are the *Eureka*, *Hinckley*, O. K., and Q. & C.

Brake-spool. Also called *Brake-shaft drum*. An enlargement by a sleeve or otherwise of a brake-shaft to give greater speed and less power to the brake-gear. A *brake-chain worm*, which see, is a somewhat similar device.

Brake-spool step (logging-cars). A U-shaped strap inclosing the brake-spool and equivalent to a *brake-step*, which see.

Brake-spring. A *release-spring*, which see.

Brake-staff. A *brake-shaft*, which see.

Brake-step. 100, figs. 229-66, etc. A small shelf or ledge on the end of a freight-car near the top, on which the brakeman stands when applying the brake from the top of a car. Also called a *brake-footboard*. A *brake-step* should not be confounded with a *brake-shaft step*, which see, which is a bearing for the lower end of a brake-shaft.

The use of brake-steps has been discouraged by the Master Car-Builders' Association, which recommended (Chicago, 1879) "that the small platform (*brake-step*) placed at one end of freight cars, to fasten the brake-pawl, etc., be discontinued, the ratchet-wheel and pawl to be fastened to a suitable casting on the roof."

Brake-step bracket. 101, figs. 229-66, etc. An iron bracket to support a brake-step.

Brake-strut. 93, figs. 4580-2, 4644-7, and figs. 4593-4, 4724-6. A compression-bar or strut between the live and dead levers of a truck with inside-hung brakes. Probably the term *Brake-strut* is more common than *Brake-lever coupling-bar*. *Brake-strut* should not be confused with *Brake-beam strut*. A *Brake-lever coupling-bar*.

In the list of names, page 328, 93 is named a *brake-lever fulcrum*, which is a misnomer, according to the terminology heretofore adopted, though technically it be a fulcrum.

Brake-treadle (hand-cars). Shown in figs. 5595-5600. A lever for applying brakes with the foot.

Brake-valve (of air or steam brakes). The valve operated by the engineman to apply brakes. See *Engineer's brake-valve* (Westinghouse), figs. 1710-12.

Brake van (English). American equivalent, *caboose* or *baggage-car*. A covered vehicle in which the conductor (guard) of a train travels, and which is fitted with a powerful screw hand-brake. On passenger trains it carries the passengers' baggage (luggage), express matter (parcels), and dogs, etc. On freight (goods) trains it is weighted with pig-iron, and is primarily used as a source of brake power. Also called *guard's van*.

Brake-windlass. A term sometimes used to designate the *brake-shaft*, which see, with all its attached parts.

Brake-wheel. 93, figs. 229-66; 157, figs. 435-73, etc. A hand-wheel attached to brake-shaft, and by which the latter is turned. Sometimes on coal-cars and elsewhere a mere bent rod is used. Fig. 354.

Brass. "An alloy of copper and zinc. The term is commonly applied to the yellow alloy of copper with about half its weight of zinc, in which case it is called by engineers *yellow-brass*; but copper alloyed with about one-ninth its weight of tin is the metal of brass ordnance or gun-metal. Similar alloys used for the 'brasses' or bearings of machinery are called *hard brass*, and when employed for statues and metals they are called *bronze*."—*Toml. Cycl. Useful Arts*.

According to present usage, alloys of copper and tin, or of copper, tin, and zinc, are termed *bronzes*, which

see. Railroad *journal-bearings*, which see, are often termed *brasses*, but they have the composition of bronzes.

Bridge. In car construction the term *bridge* means a timber, bar, or beam which is supported at each end. See *Bolster-bridge*. *Center-bearing bridge*. *Side-bearing bridge*.

Bridging. (Passenger-car framing.) 6, figs. 435-73. Short transverse distance blocks between the sills of an under-frame to keep the sills from displacement or buckling. A sill tie-rod is usually employed to keep the sills drawn tightly against the bridging. It is toenailed and sometimes tenoned into the sills, with small tenons.

"**Brilliant**" **Argand-burner.** Fig. 3369. See *Argand-burner*.

Brill's Eureka maximum-traction pivotal-trucks(street-cars.) Fig. 5644.

Brill's standard street-car truck. Fig. 5668.

Broad-band elliptic spring. Fig. 4004. See *Seat-spring*.

Broad-base jack. Figs. 3728-3745. See *Jack-screw*. *Hydraulic-jack*.

Broad-gage. A term applied to a gage when the distance between the head of the rails is greater than 4 ft. 9 ins. The principal broad gage was 5 ft.; other gages were 5 ft. 3 ins., 5 ft. 6 in., 6 ft. 00 in., etc. These gages have been abandoned and the 4 ft. 8½ in. or 4 ft. 9 in. gage adopted throughout this country on all lines. The broad gages, if any exist, are confined to short branches of no importance. Tracks of 4 ft. 8½ and 4 ft. 9 in. gage allow cars which are gaged by the *Interchange rules* to pass over them. See *Narrow-gage*. *Standard-gage*.

Broad-lace (English). 206, fig. 503. A woolen fabric made in bands about 4 ins. wide and used as an ornamental border to the upholstery of a carriage.

Broad-tread wheel. A wheel of which the tread is wider than usual, so as to be able to run over 4 ft. 8½ in., 4 ft. 9 in. and 4 ft. 10 in. gages. Also called *compromise-wheels*. They are now rarely, if ever, used, the standard tread having superseded all others.

Brooks-car seals. Figs. 3877, etc.

Broom-holders. Figs. 3695-7, 3699-3700.

Bronze. An alloy composed of copper and tin, sometimes with a little zinc and lead. Bronzes also often contain various other metals and chemical substances, as *phosphor-bronze*, which see. *Brass* is an alloy of copper and zinc. Most journal-bearings are bronzes. The variety of proportions of the various metals is very great.

Brown's emergency-link coupler. Figs. 2082-7.

Brunswick wheels. Figs. 5292-7. A type of steel-tired wheels made by Page, Newell & Co., Boston, supposed to take its name from the *Brunswick tire-fastening*, which is a modified form of the *Gibson tire-fastening*. Other wheels made by this company and fastened by *Mansell rings*, *Gibson*, and *bolted fastenings* are also called Brunswick wheels by the manufacturers.

Brush. Figs. 3698, etc. See *Car-window brush*.

Brush-and-comb rack. Figs. 3511-24.

Buckeye (Little-giant) **car-coupler.** Figs. 2088-96.

Buckle (English). 23, figs. 348-51, 501-4. See *Bearing-spring buckle*.

Buda corrugated steel wheel (for hand-cars.) Figs. 5620-2. A wheel, the tread, flange, and web of which are formed from a single plate of steel by the "drawing" and "spinning" processes, which is calculated to prevent the shocks and strains to which the metal might be subjected under a drop hammer.

Buda hand-cars. Figs. 5591 and 5598-5600. Details are fully shown.

Buffer. An elastic apparatus or cushion attached to the end of a car to receive the concussions of other cars running against it. The term is generally applied to those attachments in which springs are used to give the apparatus elasticity. The term is often applied to a *drawbar*,

which see. The buffing apparatus now largely in use on new equipment are:

The Janney-Buhoup, 2301-2350;

The Gould (which embodies features of the *Miller* and *Cowell* platform and buffer), figs. 2296-2300;

The Miller platform and buffing apparatus, figs. 2290-4.

The Thurmond-McKeen, figs. 2278-81.

In addition the Leonard Hydrostatic Buffer deserves notice, though its application has been limited, figs. 2351-4. Others not illustrated but in use are the *Janney*, the *Buhoup-Miller*, and *Janney-Miller*.

For the combination of buffing apparatus with *Vestibule face-plate* see figs. 2425-45.

Buffer-arm. A *Drawbar timber*, which see.

Buffer-band (street-cars). 87, figs. 5654-8. A band of iron or steel fastened to the buffer-beam to save it from wear and bruising.

Buffer-bar. A wrought-iron bar at the end of a car, carrying a *buffer*, which see. They are used with the *Miller*, *Janney*, *Gould*, *Thurmond*, *McKeen*, and *Leonard* Hydrostatic buffing apparatus. See *Buffer-stem*.

Buffer-beam. 1. (Freight-cars.) 32a and 32', figs. 229-66, etc. A transverse timber bolted to the outside of an end-sill of a car to which the *buffer-blocks* are attached.

2. (Passenger-cars.) A term sometimes used to designate a *platform bend-timer*.

Buffer-blocks. 29 and 32, figs. 229-66, etc. Two blocks of wood or iron attached to the end-sill or buffer-beam of a freight-car, in contradistinction to *buffer-beam*, which is a *single block* in the middle of the end-sill, although the latter also is sometimes designated as a *single dead-block*.

Buffer-blocks are sometimes called *dead-blocks*.

Buffer-blocks, dimensions and location (M. C. B. Recommended Practice). 1. Figs. 5440-2 and 5548-51. The M. C. B. standard dimensions of buffer-blocks and their location, recommended in 1873, are shown in figs. 5540-2 and 5548-51. *Buffer-blocks* are to be made 8 ins. square on the face and 6 ins. thick, and are to be placed 22 ins. apart from center to center, and to have 14 ins. space between them.

Single dead-blocks are to be not less than 30 ins. long, 7 ins. thick, and 8 ins. deep measured vertically. In 1893 a Recommended Practice as shown was adopted for buffer blocks, single and double, and location for same suitable for the old link and pin couplers. The beam 36 by 8 by 4 inches shown with the location of double-buffer blocks may be omitted if construction of car permits.

2. (English.) A piece of hard-wood packing, interposed between the *buffer-rod guide* and the *head-stock*. This term is also improperly used to describe the *buffer-rod guide*, which see.

Buffer-block face-plate. A metal plate bolted to the face of a wooden buffer-block to protect the wood from wear.

Buffer-block front-plates. Figs. 1271-2.

Buffer-chafing plates. Figs. 1238-9.

Buffer-cushion. A circular rubber pad, to prevent the platform or buffer-springs from being overloaded.

Buffer-guide. 22, figs. 2296-9, and 186, figs. 2301 and 2326. The malleable iron sleeve carrying the buffer-shank through the platform end-timber.

Buffer-head. 21, figs. 2296-9; 168, fig. 2301; 35, figs. 2290-2. A broad flat end of a buffer in draw-gear. In English cars they are about 12 ins. in diameter; in America the *side* and *center buffer-stems* are often connected by a *buffer-plate* varying from 6 by 36 ins. to 7 by 40 ins. when the vestibule is applied. See figs. 2295-2354. In the *Hydrostatic buffer* the plate extends the full width of the car. See *Buffer*.

2. (English.) 47, figs. 348-5 and 501-4. See above. Equivalent, *side-buffer*.

Buffer-plate. 22, figs. 2293-5; 21, figs. 2296-9. A plate (usually bolted to the end of the *buffer-stems*) which

- bears and rubs against the opposing plate of the next car of the train. The *vestibule face-plate* is bolted or riveted to, and carried by, the buffer-plate. Figs. 2438-45.
- Buffer-rod** (English). 48, figs. 348-51 and 501-4. A rod which transmits buffing strains from the *buffer-head* to the *buffer-spring*. See also *Buffer-stem*.
- Buffer-rod guide, or buffer-block** (English). 49, figs. 348-51 and 501-4. A casting bolted to the outer side of the *end-sill* or *head-stock*.
- Buffer-rod shoe** (English). 50, figs. 349 and 502. A casting keyed to the end of the *buffer-rod* which bears on the *buffing-spring*.
- Buffer safety-lug**. Figs. 2079-2243. A projecting horn cast on top of freight drawbars to bear against a buffer-block and relieve the draw-gear from excessive compressive strains. Is very common on freight-car couplers.
- Buffer-shank**. 36, figs. 2390-2. The square part between the buffer-head and buffer-stem.
- Buffer-side-spring yoke** (Gould platform). Figs. 1413-15.
- Buffer side-stem thimbles** (Gould platform). Figs. 1426-7; 42, figs. 2296-2300. They are short pieces of 1½-inch gas-pipe fitted over the end of the *side-stems* between the *side-stem guide* and the *stem-key*.
- Buffer-spring 1.** (Passenger-cars.) 140, fig. 2301; 49 and 47, figs. 2296-9. In the Janney, Gould, and other platform equipments, the springs that resist the compression of a train or the impact when they come together as in coupling. In passenger equipment this thrust is not taken by the draw-bar alone, but by the *buffers*, which transmit it to the buffer-springs, which absorb or transmit it to the car-body. In the Janney platform there are two side buffer-springs, figs. 2301-2350; the Gould has two *side buffer-springs* and a *center buffer-spring*, figs. 2296-9. In the Miller and Thurmond-McKeen, each has one *center buffer-spring*; but see a modified type of the Miller platform in figs. 2293-5, with two side *buffer-springs*.
2. (Freight-cars.) Figs. 1936-2072. A synonymous term for *draft-spring*, there being but one spring for buffing and draft strains. *Draft-spring* is the preferred term, although both are used.
- Buffer-spring beam** (Miller coupler). 24, figs. 2290-2. A short transverse timber framed between the draw-timbers, against which the buffer-spring bears.
- Buffer-spring bed** (English). 8, figs. 348-51 and 501-4. Serves the purpose of the American *draft-timber*. A timber in the center of the under-frame which receives the thrust of the buffing-spring.
- Buffer-spring cup** (Miller coupler). 6, figs. 2290-2. An iron seat in which the inside end of the buffer-spring rests, when a volute spring; when a spiral spring is used, the spring-cup is the same as the *buffer-spring washer*.
- Buffer-spring washer** (Miller coupler). 7, figs. 2290-2. See *Buffer-spring cup*.
- Buffer-stems**. 37, figs. 2290-2; 45, 46, figs. 2296-2300; 133, fig. 2301. Bar or stem connecting the *buffer-plate* with the *buffing-springs* through *stem-followers*. They transmit the thrust against the *buffer-plate* to the springs, and in the *Janney-Buhoup* platform equipment, fig. 2301, they connect with the equalizer bar, with the spring between. In the *Gould platform equipment*, figs. 2296-2300, there are three stems: a *center buffer-stem*, and two *side buffer-stems*. The *Janney-Buhoup* has two *side buffer-stems*, and the *Miller-platform* has only a *center-stem*.
- Buffer-stem** (Miller buffer-bar). The round part which passes through the buffer-springs. The term is sometimes applied to the *buffer-bar* which includes the round *stem* and the square *shank*.
- Buffer-stem cylinders and pistons** (Leonard Hydrostatic buffer). D, E, G, H, figs. 2351-4. Cylinders into which the *center* and *side buffer-stems* fit, and the *pistons* which they contain.
- Buffer-stem guides**. Figs. 1404-27 and 22, 23, 36, 37, 43, figs. 2296-2300. Iron bushings inserted in the *platform-end sill*, in which the buffer-stems work. They are to protect the wood from abrasion and wear. There are in the *Gould platform* six such guides, three *outer* and three *inner* guides. They are: one *outer-center-stem-guide*, two *outer-side-stem-guides*, one *inner-center-stem-guide* and two *inner-side-stem-guides*.
- Buffer-stem washer** (Miller coupler). The bearing for the key in the end of the buffer-bar.
- Buffer-thimble** (Miller coupler). A cast-iron bushing in the platform-end timber.
- Buffet** (boo-fāy', Fr.). Figs. 114, 128, 133, 175, 178, etc. A sideboard. Hence—
- Buffet-car** (boo-fāy'-car). A term (meaning, literally, *sideboard-car*) applied to a style of sleeping-car or parlor-car which has an ornamental buffet where light lunches can be prepared for the passengers. *Buffet-smoking cars* are also built in the same general style of finish.
- Buffing and draw spring** (English). See *Plate buffing and draw-spring*.
- Buffing sub-sill**. 212, figs. 278-82. A sub-sill bolted to the center-sills on the under side and forming a continuous buffing sill in conjunction with the draft timbers. They are bolted and keyed to the center-sills with key blocks and bolts. Also called *Back-stop timber*, figs. 628-9 and 647-8.
- Bullion-van** (English). A covered vehicle adapted to run on passenger trains for the conveyance of specially valuable property. The body is built of stout iron plates and the doors provided with special locks.
- Bull's-eye**. A convex glass lens, which is placed in front of a lamp to concentrate the light so as to make it more conspicuous for a signal. They are used to close the opening in fixed lamps at the ends of cars, and also in signal lanterns. See *Semaphore lens*, figs. 3442-3, and *Fresnel lens*, figs. 3440-1.
- Bull's-eye lamp**. See *Signal-lamp*.
- Bumper**. An indefinite term used to designate a *buffer* or *drawbar*, or a *buffer-block*, which see.
- Bumper-block**. A *buffer-block*, which see.
- Bundle-rack**. See *Basket-rack*.
- Bunk**. 1. A rough form of sleeping-berth permanently built against the side of a car. Is also applied to the upper berth of a sleeping-car, though it be finished and decorated.
2. (Logging-cars.) 12, figs. 352-4. A cross-piece similar to a body-bolster on which timber is loaded. See *Body-bolster*.
- Bunk-apron**. B, fig. 2408. In a sleeping-car, a board nailed to the upper-deck sill and projecting several inches below it to cover the edge of the upper-berth when it is folded up. In the latest Pullman pattern of berths it has been done away with, by rounding the edge of the upper-berth or *bunk* and closing the upper edge against the *upper-deck sill* as shown in fig. 2409.
- Bunk-partition**. O, fig. 2408. The partition between the two upper-berths of two adjacent sleeping-car sections.
- Bunk-panel**. 21, figs. 2409-12. A window panel below the *inside-cornice fascia-board* of a sleeping-car, in the upper-berth. It shuts off the upper part of the car window, marked H, fig. 2408.
- Bunk-truss** (logging-cars). Fig. 352-4. An iron strap to stiffen the bunk.
- Bunter-beam**. 7, figs. 410-13. A *buffer-beam*.
- Buntin's car-seat frame**; also termed *Reversible seats*. Fig. 3993. A mode of combining the seat and seat-back into one piece, the whole seat reversing by swinging the combined seat and seat-back downward, so that what was the seat becomes the back, and *vice versa*, instead of turning the back only as in the usual manner.
- Burlap**. A coarse canvas for use in car upholstery, generally manufactured 24 or 40 ins. wide.

Burner. Figs. 3363-97. "That part of a lighting apparatus at which combustion takes place."—*Knight*. See *Lamp-burner*. Special varieties, which see, are—

<i>Argand-burner.</i>	<i>Minot heating-burner.</i>
<i>Bracket gas-burner.</i>	<i>Pintsch burner.</i>
<i>Dual burner.</i>	<i>Screw burner.</i>
<i>Gas-burner.</i>	<i>Spring burner.</i>
<i>Hinge burner.</i>	<i>Sun burner, etc., etc.</i>

Burner cock (Pintsch system gas-lighting). 21, fig. 3183. It is used in *wall-lamp* No. 205 (fig. 3247) only. This cock is handled with *key* 46 (fig. 3215).

Burton stock car. 1. (For horses.) Figs. 45-7. A car specially designed for the transportation of valuable horses and trotting stock.

2. (For cattle.) One of the older and best arranged cars for the proper transportation of cattle. Arrangements are made for feeding, watering, and protection of the stock.

Bushing. "A lining for a hole."—*Knight*. Usually a metal cylindrical ring which forms a bearing for some other object, as a shaft, valve, etc., which is inserted in the hole. Often contracted into *bush*.

See <i>Bell-cord bushing.</i>	<i>Pipe bushing.</i>
<i>Berth-curtain-rod-bushing.</i>	<i>Reversing-valve bushing.</i>
<i>Berth-hinge bushing.</i>	<i>Sash-lock bushing.</i>
<i>Brake-shaft bushing.</i>	<i>Steam-valve bushing.</i>
<i>Deck-sash pivot bushing.</i>	<i>Upper steam valve bushing.</i>
<i>Head-board bushing.</i>	<i>Window-blind bushing.</i>
<i>Lower steam-valve bushing.</i>	<i>Window-rod bushing.</i>

2. (Pipe-fitting, which see.) Fig. 2942, 2955. A short tube with a screw cut inside and outside, used to screw into a pipe to reduce its diameter. Generally, a bushing has a hexagonal head by which it is turned, and is sometimes called *reducer*.

Bushnell-seats. Figs. 3901-8. A car seat the special features of which are the upholstering, and especially the adjustment of the springs. The seat frame has been improved and is of the modern type, tilting the cushion and inclining the back.

Bushnell seat-cushion. Figs. 3904-8. A seat-cushion patented by E. L. Bushnell. See *Seat-cushion*.

Business-car. A term often applied to an *officer's* or *director's-car*, and sometimes applied to a *pay-car*.

Burrowe's automatic car-shade. Figs. 4548-9. A car shade with an automatic shade holder at the bottom, which consists of two rods with rubber tips and springs which keep the tips pressed out against the window casings. The shade is released by pressing the two rods together by thumb latches.

Butler draw-bar attachment. Figs. 2007-17. A form of attachment using the strap-pocket or yoke with thimbles, which engage in what is termed a *case* or *housing* with lugs on the side that engage in grooves cut in the draft-timbers. In the *Graham draft-rigging* this case is called a *check-casting*.

Butt. A contraction of *butt-hinge*, which see, and generally used as a substitute for the longer term.

Butt-hinge. A hinge for hanging doors, etc., which is fastened with screws to the edge of a door, so that when the latter is closed the hinge is folded up between the door and its frame. A hinge like that represented in fig. 2616, the two parts of which are so fastened together that they cannot readily be detached, is called a *fast-joint butt-hinge*. Other forms are: *loose-joint butt-hinge*, fig. 2591-2, and *loose-pin butt-hinge*, fig. 2598. In fig. 2586 the wear is taken by a hinge-pin screwing into the knuckle and bearing against a washer. The hinge-pin is often ornamented with an acorn; and those having a washer between the two knuckles, but no acorns, are known as *Blake butts*, which see. The best butt-hinges have washers, which are generally plain, but figs. 2593-7 show a butt-hinge with ball-bearing washers. Butt-hinges are commonly termed simply *butts*.

Button. This term, besides its usual meaning, has been used to designate an *axle-collar*, but the term is now obsolete.

See <i>Door-sash button.</i>	<i>Tufting-button.</i>
<i>Door-base-sash button.</i>	<i>Solid-leather button.</i>
<i>Eccentric window button.</i>	<i>V-window button.</i>
<i>L-window button.</i>	<i>Wheel-box button.</i>
<i>Pull-rod button.</i>	<i>Window-button.</i>

C

Cabin (pile-driver car). Figs. 401-4. A small house for the engine and hoisting-gear, usually built on the *swing-ing platform*.

Cabin-car. Figs. 50-1, 385-8. A term sometimes applied to *caboose cars*, which see; more particularly four-wheeled caboose cars.

Cabin-scantling (pile-driver car). Figs. 401-4. See *Scantling*.

Cabin-shutter (pile-driver car). 13, figs. 401-4.

Cable-car. Figs. 5642, 5645. A car designed for a street railway in which the tractive power is a cable. The cable is usually placed between the rails and under ground in a conduit.

Caboose-bolster-springs. Fig. 5218 a-b.

Caboose-car. Figs. 50-4, 380-8. A car attached to the rear of all freight trains, for the accommodation of the conductor and trainmen, and for carrying the various stores, tools, etc., required on freight trains. Also, but rarely, called *conductor's car* or *train-car*. Cabooses are made with a *lookout* for displaying train signals to the locomotive and trains following, and to give the trainmen a view of the train. Caboose cars are either *four-wheel* or *eight-wheel*, and both are in general use; four-wheeled cabooses are sometimes termed *cabin-cars*. The eight-wheel cabooses are frequently provided with lockers, cooking-stove, writing-desks, and other conveniences for living.

Caboose-stoves. Figs. 3061-3105. A stove for heating a caboose-car and by which trainmen may warm their lunch, and even do some cooking if necessary.

Cafe-car. Figs. 104, 114. A buffet-dining car, in which only a light lunch is served. It differs from a *dining-car* in that the food is not cooked or prepared on the car.

Cage. See *Tank-valve cage*.

California car-coupler. Figs. 2099-2111.

Caldwell sash-balance. Fig. 4543. See *Sash-balance*.

Cam (driving-wheel brake). 15, fig. 1747. See *Eccentric levers*.

Camber. The upward deflection or bend of a beam, girder, or truss. Freight-cars are usually heavily cambered when new by screwing up the body truss-rods. Passenger cars have little or no camber.

Cam-screw (driving-wheel brake). 19, fig. 1747.

Canda cattle-car. Figs. 40, 359-64. A stock-car having some novel features of construction, which include a *deck-roof*, fig. 362, end-door trussing to prevent bulging of end, figs. 363-4; alternate-doors, and a flexible folding partition in the middle of the car, fig. 359.

The partition and arrangements for feeding and watering may be folded out of the way at a moment's notice. It is provided with end-doors for loading lumber and rails, and is equipped with Canda swing-motion trucks, figs. 4792-4803.

Canda contracting-chill. Figs. 5368-73. See *Chill*.

Canda draw-bar attachment. Figs. 2018-26. The essential feature of this attachment is the housing which contains the draft-spring. It is built of four malleable iron plates; the top and bottom plates interlock with the sides and make substantially a solid spring pocket. The side-plates are bolted and gained into the draft-timbers and bolted in such a manner that the bottom plate can be removed and the strap-end of the draw-bar with the draft-spring dropped down, without the side and top

plates being detached from the draft-timbers. The construction is said to effect considerable saving of time in making repairs.

Canda freight-car truck. Figs. 4792-4803. This is a modified type of the "Suspension-car truck" with the number of parts considerably diminished. The essential features of it are: 1, the lateral motion of each pair of wheels in the truck-frame, which is accomplished by hanging the truck-frame in stirrups, over the journal-boxes; 2, the carrying of the car-body and load on V-shaped *body side-bearings*, which bear upon *swing-links* supported in a *body-bearing casting*, which last is also the *spring-cap*. The truck has a *center-plate*, but it acts only as a guide and does not carry the car-body or load. The truck has *transoms*, but no *body-bolster* or *spring-plank*.

Canda refrigerator-car. Figs. 12, 233-6. A refrigerator-car whose chief features are: (1) the insulation, (2) the economic method of effecting it, (3) the arrangements for icing, (4) the circulation of air within the car. The insulation (see also figs. 1860-2, 2020) consists of an exterior sheathing of boards which are fluted on inside and allow a circulation of free air beneath them. This is to put the car in the shade and to give a free circulation of air around about the inclosed and shaded car, thus preventing the heat of the sun penetrating to the insulated part of the car. Beneath this exterior sheathing of weather-boards is a sub-sheathing, several layers of tar paper, one of felt 1 in. thick, two $\frac{3}{4}$ -wood partitions and a lining $\frac{3}{8}$ in. thick. The tar paper is tacked upon both sides of triangular frames, which frames wedge the felt in place, thus saving any nailing and fitting.

The construction of the ice-crates is shown in the engraving, the air circulating through the crate and through its slats in at the top and out at bottom, beneath the slatted floor and up into the car.

Canda refrigerator car-door. Figs. 12, 1860-2. A door that is set in 5 $\frac{1}{2}$ ins. so that the outside frame may be flush with the siding. The door is made tight by forcing it bodily into the door-casing against rubber packing, by toggle-joints actuated by a lever on an eccentric rod, as shown. The door is carried on a frame that slides on a track somewhat like an ordinary freight-car door.

Canda sliding-bottom gondola. Figs. 321-4. See *Slide-bottom gondola*.

Candelabrum. 10, figs. 2452-3a. A bracketed or suspended chandelier carrying several candles, or gas-jets in imitation of candles.

Candle. A special kind of large diameter called *car-candles* are used for lighting passenger-cars and burned in *candle-lamps*, figs. 3259 and 3294-6, which see. Since the introduction of high-proof mineral oils they are now rarely used. The best car-candles are made of paraffin and *hydraulic pressed*.

Candle-bottom. Figs. 3248, 3259, and 3383. See *Candle-lamp*.

Candle bracket-lamps (Pintsch system). Figs. 3244-5 and 3248-9. Are for use in emergency, as in case gas gives out. May be attached to wall or to any center-lamp at will.

Candle-holder. Fig. 3384. See *Candle-lamp*.

Candle-holder cap. 21, fig. 3384. See *Candle-lamp*.

Candle-holder cup. 22, fig. 3384. See *Candle-lamp*.

Candle-lamp. Figs. 3243-4, 3248-9, 3259, 3294-6. A lamp for burning candles, sometimes elaborated into a *chandelier* with two or three burners. Candles, however, are now but little used except in Emergency bracket-lamps, to be used when the gas or electric lights fail. A pattern is shown in figs. 3243-4 and 3248-9. The candle is placed within a *candle-holder*, fig. 3384, carried within a *candle-bottom*, fig. 3383. The candle-holder consists of a *candle-holder cup* and *candle-holder cap* connected by the *candle-rods*, fig. 3384, and having a light spiral *candle-spring* within. As the candle burns

away it is pressed upward by the candle-spring against the cap so as to keep the flame always in one position.

Candle-rods. 23, fig. 3384. See *Candle-lamp*.

Candle-spring. 24, fig. 3384. See *Candle-lamp*.

Calaminated iron. See *Kalaminated iron*.

Callender lamp-burner. Fig. 3381. One of the no-chimney burners.

Cam (Yale lock). The revolving-disk, usually of a spiral eccentric or heart-shape, fixed on the outside of the shaft which carries the *tumblers*.

Cane-seat. Figs. 3943-6, 3990. A seat made of woven strips of cane or rattan. For additional strength it is now often *canvas-lined*, the cane seating then coming in rolls. The cane, or rattan, is woven close and cemented to the canvas. Fig. 3912.

Cannon-car. Fig. 4804. A car specially constructed for carrying heavy cannon. Also called *gun-car*.

Canopy. Figs. 3438-53. See *Lamp-canopy*. Also called a *smoke-bell*, which see. A platform-hood is sometimes called a *canopy*.

Canopy return-ribs. Figs. 1239-40.

Canopy-ventilator. Fig. 4304. See *Ventilators*.

Cantilever-truss (overhang of underframe). Shown in fig. 512, and **V**, fig. 514. An inverted truss which bears upon the side-sill directly over the body-bolster. The inner end is connected by a tie-rod to the inner end of the truss at the other end of the car-body, while the outer end supports the overhang of the underframe by a vertical tie-rod and by a diagonal brace-rod similar to the overhang truss-rod of the old Pullman framing. It is clearly shown in fig. 512.

Cant-rail (English). 98, figs. 501-4. American equivalent, *plate*. A horizontal timber running along the top of the upright pieces in the sides of the body, and supporting the roof and *roof-sticks*. Its upper edge is cut to the bevel of the roof; hence its name.

Canvas. A coarse cloth, made of cotton, used for outside covering of street-car roofs and for upholstering seats. *Roofing-canvas* is used for covering street-cars.

Canvas-lined seating. Fig. 3912. See *Cane-seat*.

Cap. The top or covering of anything.

See *Arm-cap*.

Belt-rail cap.

Bolster-spring cap.

Brake-hose coupling-cap.

Candle-holder cap.

Equalizing-bar-spring

cap.

Inside-lining cap.

Leakage-valve cap.

Left-chamber cap.

Lever-frame cap.

Lower cap of triple-valve.

Main cap of triple-valve.

Reversing-cylinder cap.

Reversing-valve cap.

Right-chamber cap.

Smoke-pipe cap.

Spiral-spring cap.

Spring-cap.

Tank-nozzle cap.

Trimming cap.

Truss plank cap.

Upper cap of triple-valve.

Window-sill cap.

Cap-casting (H. & K. reclining seat). 55, fig. 3922.

Cap-screws (air-pump). 111, figs. 1691-2.

Car. The term used in the United States to designate a vehicle or carriage for running on a railroad. As the term is usually employed, it denotes any vehicle used for transportation and not belonging to the motive power of a railroad.

The term *Coach*, which see, is synonymous with *passenger car*. In England passenger-cars, or coaches, are called *carriages* (*first, second, and third class*), and freight cars, *wagons, or trucks, and vans*, all of which see.

Cars are divided into two general classes, *passenger-cars* and *freight-cars*. The latter is also further subdivided into freight-cars proper and *working or construction cars*, the latter including a great variety of types, but a comparatively small number of each type. The prices allowed by the Master Car-Builders' Association for the various forms of freight-cars will be seen under *Freight-car*, which see. *Street-cars*, for city and suburban use, take their names from the motive power employed to move them, as *Horse-cars, Electric-motor cars, Cable-cars*, etc. They constitute a class by themselves, which see. *Hand-cars*, which see, are a light vehicle moved by

hand-power, and under this head should be classed *Velocipede-cars*. Among passenger-equipment cars the following vehicles are usually classed, not because they carry passengers alone, but rather for the reason that they are run in trains which carry passengers:

<i>Baggage car.</i>	<i>Mail car.</i>
<i>Bay-window parlor car.</i>	<i>Officers' car.</i>
<i>Buffet sleeping car.</i>	<i>Palace car.</i>
<i>Combination baggage car.</i>	<i>Parlor car.</i>
<i>Dining car.</i>	<i>Passenger car or coach (first-class and second-class).</i>
<i>Drawing-room, or parlor car.</i>	<i>Pay car.</i>
<i>Excursion car.</i>	<i>Postal car.</i>
<i>Express car.</i>	<i>Private car.</i>
<i>Hotel car.</i>	<i>Sleeping car.</i>
	<i>Smoking car.</i>

Among the cars for regular freight service are:

<i>Box car.</i>	<i>Grain car.</i>
<i>Box fruit car.</i>	<i>Gravel car.</i>
<i>Box stock car.</i>	<i>Gun car.</i>
<i>Caboose car or cabin car.</i>	<i>Heater car.</i>
<i>Cannon car.</i>	<i>Hopper-bottom car.</i>
<i>Coal car.</i>	<i>Ice car.</i>
<i>Coal dump car.</i>	<i>Iron-hopper coal car.</i>
<i>Club car.</i>	<i>Lumber car.</i>
<i>Double-deck car.</i>	<i>Milk car.</i>
<i>Drop-bottom car.</i>	<i>Mine car.</i>
<i>Dump car.</i>	<i>Oil or tank car.</i>
<i>Flat car.</i>	<i>Ore car.</i>
<i>Fruit car.</i>	<i>Poultry car.</i>
<i>Furniture car.</i>	<i>Refrigerator car.</i>
<i>Gondola car.</i>	<i>Stock car.</i>
	<i>Tip car.</i>

Among working cars are:

<i>Air-brake-instruction car.</i>	<i>Locomotive crane.</i>
<i>Boarding car.</i>	<i>Pile-driver car.</i>
<i>Derrick car.</i>	<i>Push-pole car.</i>
<i>Ditching car.</i>	<i>Sweeping car.</i>
<i>Ferry push-car.</i>	<i>Snow-plow or flanger.</i>
<i>Inspection car.</i>	<i>Tool car.</i>
	<i>Wrecking car.</i>

Freight-cars are also generally designated as *four-wheel* or *eight-wheel*, the latter carried on two *trucks* of four wheels each, and including an immense majority of American rolling-stock. In fact the four-wheeled freight-car may be counted one of the things of the past. *Iron cars* having the sills, cross-tie timbers and bolsters of structural iron shapes have been built in late years and some have been built entirely of iron and steel, but they have not found much favor with American railroads. Many so-called *tubular-iron cars*, whose framing was of wrought-iron pipe, have also been built and are in limited use. There are three prime reasons why iron cars have not found favor: First, those who designed the cars already built did not anticipate the development which American rolling-stock has undergone, and provide for the greater burdens which their cars have had to endure; secondly, there has been considerable difficulty experienced in matters of repair, repair-shops not having been equipped for, nor the car repairers trained to, iron-work; thirdly, the additional first cost over and above that of wood cars has forbidden their universal adoption.

Car-axle. Figs. 5419-20. M. C. B. Standard. Also, 2, figs. 4580-4966. A shaft made of wrought-iron or steel to which a pair of car-wheels is attached. In nearly all cases the wheels are both rigidly fastened to the axle, but sometimes one or both of them are made so that it can turn independently of the axle. The following are the names of the parts of an axle: *Center of axle*, *Neck of axle*, *Wheel-scat*, *Dust-guard bearing*, *Collar*, *Journal*. See *Axle*. *Hammered car-axle*.

Car-bodies. Figs. 229-615.

Car-body details. Figs. 617-2453a.

Car-box. A *journal-box*, which see.

Car-box jack-screw. Figs. 3730-1, 3731, 3752. A low screw or hydraulic jack to fit under a journal-box so as to take the load off the journal-bearing and enable it to be removed.

Carburetor (Frost system of car-lighting). Figs. 3121-3, 3130-2. The carburetor is a square box, hermetically sealed, which is provided with an internal spiral chamber, 15, figs. 3121-3, sixty feet long, filled with capillary material. It has also a *carburetor flue*, which provides for the passage of air from the inside of the car. As a means of furnishing heat to the carburetor, it is surrounded with an air space which communicates with the inside of the car, so that warm air from the car constantly passes around the outside of the carburetor and out through the *ventilator*. To protect the car from the extremes of heat and cold, it is surrounded by a double mantle lined with hair-felt.

The air is supplied to the carburetor by means of the *roof-pipe*, and is conducted through the *tee*, 9, and the *air-pipe*, 10, to the *copper-coil*, 11, where it is heated by the lamp. From the coil, the heated air passes to the *air-inlet*, 12, where the current is divided. The greater part of the air passes down through this casting into the interior of the carburetor and the remainder continues its course through the air tube to the *by-pass nipple*, 14, in which is located a *diaphragm*, with a hole of sufficient size to admit of the passage of a limited amount of uncarbureted air. The air which has entered the carburetor at the *air-inlet*, 12, moves slowly through the *spiral-chamber*, 15, filled with capillary material partly saturated with gasoline. While following this passage, the air absorbs the gasoline vapor, and the gas thus formed issues from the *gas-outlet*, 16, where it is brought in contact with the uncarbureted air, which has passed through the *by-pass nipple*, 14, as previously described, and is thereby diluted. From the gas outlet, the gas passes downward through the *gas-nipple*, 17, and the *gas-arm-ell*, 18, to the lamp.

The process of filling the carburetor is as follows: The filling can, fig. 3142, is inverted and connected with the carburetor valves, as shown in fig. 3152. After opening the *carburetor filling-valve*, 5, and the *carburetor bleed-valve*, 6, on both the carburetor and can, the gasoline flows by gravity into the carburetor and is conducted through the *troughs*, 19, to the absorbent wicking. Carbureted air to replace the gasoline passes up through the *bleed-well tube*, 21, and *nipple*, 22, to the *bleed-valve*, 6, and thence into the can. As soon as the wicking has become saturated, the excess oil collects in the *bleed-well* and prevents the further flow of oil from the can.

Car-candle. See *Candle*.

Car-coupler. An appliance for connecting or coupling cars together. All passenger-car couplers and the greater part of the freight-car couplers in use are automatic.

By Act of Congress, Feb. 27, 1893, all engines, passenger and freight cars engaged in interstate commerce must be equipped with couplers, that couple automatically by impact and that may be uncoupled without going between the cars, on or before Jan. 1, 1898. A penalty of \$100 is imposed for each violation of this act, unless the time shall have been extended for each road by the Interstate Commerce Commission after a hearing and for a good cause.

This act and the anticipation of such legislation by the roads have been strong factors in the abandonment of the old link-and-pin drawbar, and the adoption of the vertical-plane automatic coupler.

Of automatic couplers there are a great many; the freight couplers all conform to the lines adopted by the M. C. B. Association and shown in fig. 5499; they differ chiefly in the lock and the device for uncoupling. The general dimensions of the coupler universally adopted for freight service are given under figs. 5499-5505 with the limit gages to which all M. C. B. couplers should conform. The same gages are applicable to passenger couplers. The method of attachment of coupler recommended by

the M. C. B. Association is shown in figs. 5507-24. Of the many couplers in use the following are frequently met:

Janney. Figs. 2161-82, 2252-4, 2301-50. And various other means of attachment not shown.
Gould. Figs. 2141-7, 2246-51, 2296-2300.
American. Figs. 2075-81.
Brown's Emergency. Figs. 2082-5.
Buckeye. Figs. 2088-96.
California. Figs. 2102-11.
Chicago. Figs. 2111a-d.
Drexel. Figs. 2112-24, 2244-5.
Elliott. Figs. 2125-40.
Hinson. Figs. 2150-60.
Johnston. Figs. 2183-89.
Smillie. Figs. 2199-2201.
Standard. Figs. 2202-8, 2256-66.
Thurmond-McKeen. Figs. 2209-22, 2277-9.
Trojan. Figs. 2229-39, 2267-74.
Van Dorsten. Figs. 2240-3, 2275-6.
Link and pin. Figs. 2073-4 and 2282-89a.

Car-cylinder (air-brake). Any one of several kinds of *brake-cylinders* shown in figs. 1727-31.

Card Electric Company's street-car motor Fig. 5676.

Car-discharge-valve (train signaling-apparatus). 32, figs. 1693-8, and fig. 2402. A valve placed in the end of the car and connected with the *signal-cord*. When the cord is pulled the *car-discharge-valve* is opened and the air escapes, which blows the whistle in the locomotive cab. See *Train signaling-apparatus*.

Car-door hangers. Figs. 2825-45, 1800-52. A device for hanging a sliding door so that it may be movable. In common practice the simple hooks upon which most freight-car doors are hung are termed simply *door-hangers*, which see, while more elaborate forms with rollers have their names expanded into *car-door hangers*.

Car-door hangers with wheels or rollers to prevent friction are termed *Door-sheaves*, of which there are various types. The type in most common use for heavy doors is shown in figs. 2825, 2827, 2829, 2834-6, in which the door carries a slotted plate, which rests upon the pivot of a large wheel which rolls upon the track; another class, figs. 2831-4, are of the "grindstone-bearing" type, the journal of the bearing-wheel proper resting upon other wheels. Other types in use are shown in figs. 2830, 2837, 2839-42, which have the single wheel in a fixed bearing.

Car-door lock. 19, fig. 1788; figs. 2644, 2735. A lock for a car-door, usually meaning for a passenger-car door. See *Freight-car lock*. *Padlock*.

Car-door sheaves. See *Door-sheaves* and *Car-door hangers*.

Car drain-cup (Automatic air-brake). Figs. 1746 and 1758-60; 6, figs. 1693-8. An attachment to the brake-pipe of every car to collect the water of condensation, which is drawn off from time to time by a cock at the bottom, it is usually combined with an *air-strainer* and so-called.

Card-rack. 80, fig. 254. A small receptacle on the outside of a freight-car to receive cards giving shipping directions.

Card-table. See *Table*.

Carey asbestos-asphalt car-roof. Figs. 2395-6. A roofing material the body of which is composed of a very heavy layer of woolen felt, thoroughly saturated with a secret compound which it is claimed preserves the roofing itself and also the upper and lower boarding with which it comes in contact. See *Car-roof*.

Car-furnishings. Figs. 2454-4575. The hardware, upholstery materials and other fittings, such as lamps, ventilators, water-coolers, etc., used in finishing a passenger-car. In general it includes those parts of a car that are applied after it has left the paint-shop.

Car-heater. Any apparatus for heating cars by convection; that is, by conveying hot water, steam, or warmed air into, or through, the car. It generally refers to any arrangement for warming cars, other than stoves. See *Baker*, *Spear*, *Consolidated*, *Gold* and *Safety*

heating-systems. See also *Stove*. *Cook-stove*. *Range*.
Carline, or carling. 81 and 82, figs. 229-66, etc.; 100, figs. 435-73, etc.; and 100, figs. 536-608. A transverse bar of wood or iron which extends across the top of a car or from one side to the other, and which supports the roof-boards. In passenger-cars carlines are divided into *main carlines*, figs. 1248-9, passing entirely across the car; *short carlines* or *deck carlines*, which are confined to the upper-deck, and *rafters*, 101, figs. 435-73, and fig. 1215, which are confined to the lower-deck. The carlines of freight-cars are also rarely called rafters. The main carlines are usually *compound*, i. e., built up of wood and iron. They sometimes pass directly from side to side of the car across and under the upper-deck, when they are termed *continuous* or *straight* carlines, but usually are bent to the outline of the clear-story, when they are termed *profile* carlines. In freight-cars the *main carline* is one made stronger than the others for carrying the purlins and roof. Other carlines having special names, which see, are:

<i>End carline.</i>	<i>Platform-roof carline.</i>
<i>Platform-hood carline.</i>	<i>Platform-roof-end carline.</i>

Carline knee-iron. b, fig. 515. An angle iron which connects the end carline to the plate.

Carlton & Stroudley fastening (steel-tired wheels). Fig. 5312. See *Tire fastening*.

Car-moldings. See *Moldings*. See also *Car-seat moldings*, figs. 4023-8, which latter are metal bands for seat-backs.

Carpet eyelet. Fig. 2852. See *Eyelet*.

Carpet-knob. An *eyelet-nail*, which see.

Car-platform. More commonly, simply *platform*, which see. See *Platform furnishings*.

Car-pump. A *basin pump*, which see.

Car-replacer. A device for getting a derailed truck back on to the track. It usually consists of two inclined planes by which the wheels are raised so that the flange of the outside wheel can ride upon and over the rail. They are placed at an acute angle with the track so as to guide the wheels and force them upon the track. See *Wrecking-frog*.

Carriage-bolt. Fig. 3710. A bolt made square under the head so as to prevent it from turning when in its place. They usually have button-shaped heads and are used for fastening wooden objects together.

Carriage, or railway carriage (English). Figs. 501-4. American equivalent, *passenger-car*, or *coach*. A vehicle for passengers, having four, six, eight, or twelve wheels (usually six wheels). It is divided into compartments by transverse *partitions* extending the full width of car. A *first-class* compartment seats six or eight passengers, and a *second* or *third class* compartment ten passengers. About 89½ per cent. of the total number of passengers travel third-class, which really corresponds to the so-called "first-class" here, the real first-class being carried in sleeping and parlor cars. The English first-class is used by about 3½ per cent. of the passengers. The second is an intermediate class which is gradually going out of use.

See also <i>Bogie carriage.</i>	<i>Second-class carriage.</i>
<i>Composite carriage.</i>	<i>Smoking carriage.</i>
<i>Corridor carriage.</i>	<i>Sleeping carriage.</i>
<i>First-class carriage.</i>	<i>Third-class carriage.</i>
<i>Lavatory carriage.</i>	<i>Tri-composite carriage,</i>
<i>Saloon carriage.</i>	or <i>tri-compo.</i>

Carriage-truck (English). An open four-wheeled vehicle, with low sides, adapted to run on passenger trains, and carry a road vehicle.

Carrier . See <i>Brake-hanger carrier.</i>	<i>Parallel brake-hanger carrier.</i>
<i>Brake-pawl carrier.</i>	<i>Spring-plank carrier.</i>
<i>Foot-rest carrier.</i>	

Car-roof. Figs. 2355-94. A covering for a car, supported by the carlines and purlins. The various forms in use in freight-car construction may be divided generally

into the four following classes: 1st, what is known as a *double-board roof*, with or without felt or other material between boards. Fig. 2379 is a simple and very largely used form. To this class belong also the *Hutchins*, fig. 2396; *Careys*, fig. 2395; and many other roofs in which the boards are tongued and grooved and have a sheet of painted canvas, asphalt roofing material, or other prepared materials between them. 2d, *Single-board roofs*, covered with tin or other sheet metal. figs. 2385, 2388-91, the *Excelsior galvanized car-roof*. 3d, Roofs made of metal sheets, fastened to purlins and roof strips, and protected by a single layer of roughly matched boards. To this class belong the *Winslow*, figs. 2355-67; the "*Chicago*" car-roof, figs. 2368-78, which is very similar to the Winslow, except that in the Winslow the sheets run clear across the roof of the car, whereas in the Chicago they are in sections, corrugated, and divided by the ridge-pole; and the *Excelsior car-roof*, in which the sheets are divided by the ridge-pole. 4th, a type of double-roof consisting of inside roof covered with felt, tar paper, or asphalted canvas, and an outside roof built over it to protect the roofing material from injury. This type is illustrated in the *Drake & Weir's roof*, fig. 2392, and the *Neponset red-rope roofing*, figs. 2393-4. Passenger car-roofs are commonly of tin, zinc, or galvanized iron or steel of about 22 W. G., painted. For street-cars, painted canvas is used. See also *Board-roof*, and the various kinds above specified. In respect to form, see *Arched-roof*, *Deck-roof*, **A** *car-roof*, and **X** *car-roof*.

Carry-iron.

See *Drawbar carry-iron*. *Inner drawbar carry-iron*.
Drawbar stirrup. *McKeen carry-iron*.
Draw-timber carry-iron.

Car-seal. Figs. 3877-3900. A device to secure freight-car doors against opening, by making it impossible without destroying the seal. The original form consisted of a lead disk with two holes to receive a piece of twisted wire, which is compressed by a die so as to leave a seal-mark which must be defaced or the wire cut before the door can be opened. To prevent stripping the seal from the wire and re-inserting it, a detective wire of irregular cross-section is used, figs. 3886-7 and 3900. Sheet-metal *eyelet-shackles*, in a variety of other forms, are now also used, with or without tin *return tags*, and also a simple lead rivet with a tin shackle. Tin shackles often have the name of the road printed on them. Of seals there are a great variety, some of the more common of which are shown. See also *Seat-locks*. *Seat-press*.

Car-seat. Figs. 3901-4115; **122**, figs. 450, and 540-1. The complete set of fixtures on which passengers sit in a car. It ordinarily consists of a *seat-frame*, *seat-cushions*, *seat-back*, *arm-rest*, *foot-rest*, and their attachments. Ordinarily, the seats in American cars are placed cross-wise of the car, and are made for two passengers. The backs of the seats are generally made reversible. In the *Buntin seat-end*, which see, etc., the seat and back are in one piece and both reversible together. These seats, and, less properly, ordinary car seats, are sometimes called *reversible seats*. The seats of parlor cars are commonly called *chairs* (see *Revolving chair*, *Hitchcock chair*, *Hartley chair*, etc.). To replace chair-cars these chairs have been superseded by so-called *twin-seats*, which see. In private and parlor cars, *sofas*, placed longitudinally against the side of the car, are sometimes used. In order to give an inclination to the seats which makes them more comfortable, various devices have been introduced. In fact all first-class car seats not only incline the seat-cushion but they move it bodily forward, as well as automatically adjust the back. Other improvements in seats, are the *head-roll*, figs. 3901, 3918; the *curved seat-back*, fig. 3968; the *extra-high seat-back*, figs. 3972; the *adjustable foot-rest*, figs. 3972-3. Other types of seats are shown as follows: *Swing-back seats*, figs. 3981-3, another type, figs. 3917-18; *Scarritt-Farney seats*,

figs. 3968-76; and *revolving-seat*, figs. 3980, and 3984-6. The covering of seats is usually plush, but sometimes *cane* or *rattan* seats, *canvas-lined cane seats*, *perforated-veneer seats*, *woven-wire seats*, which see, are used. The seats of *street-cars* are usually placed longitudinally on each side of the car, as shown in fig. 3947, but in *open-cars* they are usually transverse and in length equal to the full width of car, figs. 5644 and 5648-9.

See also *Cane-seat*. *Rattan car-seat*.
Mason rocker-seat. *Side-seat*.
Perforated-veneer seat. *Woven-wire seat*.

Car-seat connecting-rod. **25**, figs. 3971-3. A round rod connecting wall and aisle seat-ends of a Scarritt seat with adjustable foot-rests.

Car-seat moldings. Figs. 4023-8. Metal bands, usually nickel-plated, used to finish seat-backs. They are either *plain* or *beaded*. See *Moldings*.

Car-signal valve (train signaling-apparatus). Figs. 2403-4. A valve placed in every car and attached to the bell-cord or signal cord, by which air is allowed to escape from the *signal-pipe*, thus blowing the *signal-whistle* on the engine. It is more often called a car-discharge valve.

Carson and Gurganus refrigerator car-doors. Figs. 1853-9. An insulated door, carried upon a frame which is hung in sheaves on a lower track. When the frame has been slid into position the door is forced into place against rubber packing by an eccentric placed upon a rod and operated by a lever.

Car-spring. Figs. 5192-5240. See *Spring*. *Spiral spring*. *Elliptic spring*. *Bolster-spring*. A general term applied to springs on which the weight of a car rests, and also to draw and buffer springs.

Car-steps. See *Platform steps*.

Car-truck. Figs. 4580-4966. Mechanically, a small low four-wheeled (or sometimes six-wheeled) car, carrying as a dead load one-half the weight of a long car-body. The car-body is usually carried on a pair of *center-plates* (truck center-plate and car-body center-plate), with a *center-pin* or *king-bolt* passing through them, about which the truck or, more properly speaking, the car-body, can swivel. In England such trucks are called "bogies." See *Truck*.

Carving-table (dining-cars). Figs. 475-6.

Car-washer. Figs. 3701-2. A brush made for washing the outside of passenger-cars. It is made of bristles or feathers.

Car-wheel. Figs. 5255-5363; **1**, figs. 4580-4966 and 5654-67. A wheel for a railroad car. Chilled-wheels are called *single-plate wheels* or *double-plate wheels*, according to the number of plates between the hub and rim. When one plate is used, it is sometimes made flat, with ribs called *brackets* on the back, and sometimes *corrugated*, without ribs. The disks of double-plate wheels also are generally corrugated. What is known as the *Washburn wheel* has two corrugated disks extending from the hub about half way to the tread, and a single plate, with curved brackets on the back, between the tread and the double plates. This wheel is generally known as a *double-plate wheel*. Cast-iron wheels are also made with spokes, either solid or hollow, principally for locomotive use. Those in use in this country are either cast-iron with a chilled tread and called chilled-wheels, or are steel tired with wrought or cast iron or combination center. For freight-cars the cast-wheel with a chilled tread is still largely in use. As to passenger-cars the M. C. B. Committee on Steel-Tired Wheels of 1894 reported that replies from car-builders representing 57 per cent. of the passenger car-equipment in this country gave the number of wheels in use as 51,862. These members reported 145,820 wheels under passenger equipment, of which 86 per cent. were steel-tired. Of the entire passenger equipment in the country, probably not more than 25 per cent. has steel-tired wheels. Of the 57 per cent. reported, of the Allen wheels

there were 13,943, the Paige 8,184, the Krupp 6,021, the Snow 3,575, the Arbel-Cockeril 3,218, the Boies 2,830, the Washburn 1,681, the Brunswick 1,287; of the other types there were less than 1,000.

The standard diameter of freight-car wheels may be said to be 33 ins.; 30 and 31-in. wheels, and wheels as small as 28 ins., and even less, are used for locomotive trucks. The average weight for a 33-in. wheel is 575 lbs. For several years there was a tendency to use wheels of large diameter for passenger cars. Forty-two inch wheels became quite common, but there has been a reaction against 42-in. wheels in favor of 36-in. wheels, which are now practically standard for passenger equipment. In England passenger wheels vary from 42 to 48 ins. in diameter, and freight-car wheels are always 36 ins. Both always have steel tires.

Prices of wheels and axles and cost of work on same has been fixed at various rates by the rules for interchange of cars of the M. C. B. Association. See *Interchange of Traffic*.

The parts of wheels are the *flange, tread, rim, tire, retaining-rings, plate, ribs, spokes, center, hub* and *axle-seat*.

The varieties of cast-iron wheels beside the single-plate, double-plate, and Washburn, above mentioned, are the *combination plate-wheel, combination wheel, hollow-spoke wheel, open-plate wheel, spoke-wheel*. Cast-steel wheels have been made, but cannot be said to be in general use. See *Steel-tired wheel* and any of the above.

In 1893 the M. C. B. Association adopted specifications for cast-iron wheels and a form of guaranty by manufacturers as Recommended Practice. These had formerly been standards of the Association; figs. 426, 7-8, M. C. B. Report. See *Wheels, specifications and guarantee*.

See also the following wheels:

<i>Allen</i> , figs. 5255-73.	<i>McCle- Fuller</i> , figs. 5306-7a.
<i>Arbel-Cockeril</i> , figs. 5274-81.	<i>Paige</i> , figs. 5308-13.
<i>Boies</i> , figs. 5282-91.	<i>Snows</i> , figs. 5321-29.
<i>Brunswick</i> , figs. 5292-97.	<i>Taylor's</i> , figs. 5316-19.
<i>Chilled-cast</i> , figs. 5335-8.	<i>Teakwood</i> , fig. 5320.
<i>Hand-car</i> , figs. 5620-34.	<i>Vauclain</i> , figs. 5314-15.
<i>Krupp</i> , figs. 5298-5305.	<i>Washburn</i> , figs. 5330-34.

Car-window blind. See *Window-blind*.

Car-window brush. Fig. 3701.

Case. "A covering, box, or sheath; that which incloses or contains: as a case for knives; a case for books; a watch-case; a pillow-case."—Webster.

See <i>Brake-hose coupling-case</i> .	<i>Leakage-valve case</i> .
<i>Door-case</i> .	<i>Spring-case</i> .
<i>Lamp-case</i> .	<i>Tool-case</i> .
<i>Lock-case</i> .	<i>Triple-valve case</i> .

2. (Rack-tumbler spring padlock.) 8, fig. 2766.

Casing. 1. (For heaters.)

See <i>Heater-pipe casing</i> .	<i>Perforated smoke-pipe casing</i> .
<i>Inside-casing</i> .	<i>Smoke-pipe casing</i> .
<i>Outside-casing</i> .	

2. (For Spear heater.) Figs. 3058-60. A cylindrical sheet-iron cover by which the fire-pot is inclosed so as to leave an air-space between the two.

3. (For windows.) The frame which surrounds a window. See *Window-casing*.

Caster. Fig. 4115. A small wheel on a swivel attached to furniture and on which it is rolled on the floor. By custom of the trade, furnishings which are in reality mere sockets or knobs, like figs. 4112-14, are termed *casters*, although they are, strictly speaking, not such, not having any rollers. They are distinguished as *chair-casters, table-casters, sofa-casters*, etc., according to size and probable use.

Caster-holder (dining-cars). Figs. 107-9. A shelf or tray for holding bottles of condiments.

Casting. Any piece of metal which has been cast in a mold.

See <i>Corner-casting</i> .	<i>Roller side-bearing casting</i> .
<i>Draubar side-casting</i> .	<i>Roof corner-casting</i> .
<i>Eccentric-lever casting</i> .	<i>Side-casting</i> .
	<i>Transom-casting</i> .

Cast-iron double-plate wheel. Figs. 5259-60, 5270-1. See *Double-plate wheel*. *Car-wheel*.

Cast-iron spoke-center wheel. Figs. 5257-8, 5292-3, 5304-5, 5312-13, etc.

Cast-iron top (Baker heater). Figs. 2901, 2912, 2921. A plate which forms the top of the fire-chamber. It has perforations around the outside and an opening in the center through which the stove is supplied with coal.

Cast-wheels. Figs. 5335-63. See *Car-wheel*. *Chilled wheel*. *Chill*.

Catch. See <i>Cupboard-catch</i> .	<i>Ratchet-catch</i> .
<i>Deck-sash catch</i> .	<i>Second catch</i> .
<i>Door-holder-catch</i> .	<i>Sliding-door-holder catch</i> .
	<i>Vestibule-gate catch</i> .

2. (Janney coupler.) 136, fig. 2301. A latch which engages with the point of Janney knuckle and secures it in position when coupled.

Catch-lever (Janney coupler). 136, fig. 2301. A crank-lever passing vertically through the catch, by means of which it is caused to release the knuckle for uncoupling.

Catch-spring (Janney coupler). 25, fig. 2301. A coiled spring on the catch-spring bolt operating the catch.

Catch-spring bolt (Janney coupler). 15, fig. 2301. The bolt on which the catch of Janney coupler slides.

Cattle-car. Figs. 33-41 and 355-72. More properly *Stock-car*, which see.

Cattle-wagon (English). American equivalent, *four-wheeled stock-car*. A four-wheeled vehicle suitable for freight service, and adapted to carry cattle, sheep, or pigs. The floor boards are laid 1 in. apart to facilitate drainage, and are covered with strips to prevent the cattle slipping.

C., B. & Q. journal-box for collarless-journals. Figs. 5138-45.

Ceiling. The inside or under surface of the roof or covering of a room or car opposite the floor. This term is sometimes used to mean *sheathing*, which see. When the ceiling of a passenger-car is made of painted canvas, or other decorated lining it is termed *head-lining*; the term ceiling in modern usage being restricted to wood ceiling. The term *panel-ceiling* is also used as synonymous with wood ceiling, although cloth head-lining is also sometimes put on in panels. *Deafening-ceiling*, which see, is boarding under the sills of the car, making an air-space between the sills. See *Lignomur, Veneering, Paneling*.

Ceiling-veneers. Thin boards with which the ceilings of passenger-cars are covered. The term is also misapplied to the thin preparations of *papier maché*, etc., in imitation of natural wood veneers.

Ceiling-furring. O, P, fig. 514. Strips or pieces fastened to the carlines overhead, and to which the paneling or veneering of the ceiling is applied.

Cement-car. Fig. 31. A car specially designed for use in cement quarries and about the works. The one shown is of steel with a hopper-bottom and drop-doors.

Central filling-piece (steel-tired wheels). Figs. 5310-11, etc. The part surrounding the hub and connecting it with the tire. Also termed the *skeleton*. A *wheel-center* is a hub and central filling-piece combined in one.

Center-bearing. The place in the center of a truck where the weight of a car-body rests. A *body center-plate* attached to the car-body here rests on a *truck center-plate* attached to the truck. The general term *center-bearing* is used to designate the whole arrangement and the functions which it performs, in distinction from *side-bearing*, which see.

Center-bearing arch-bar. 66, figs. 4955-66. See *Center-bearing-bridge*.

Center-bearing beam. 65, figs. 4957-66. See below.

- Center-bearing bridge** (six-wheel trucks). 66-7, figs. 4957-66. A longitudinal iron beam, formerly sometimes a wooden beam, the ends of which rest upon the *spring-beams* and by which the truck *center-bearing-beam*, 65, carrying the *center-plates*, is supported. It consists of the *center-bearing arch-bar* and *inverted arch-bar*, inclosing between them the center-bearing beam. *Truck side-bearings*, 61, similar in form to an arch-bar, are also attached to the extremities of the spring-beams, connecting them together.
- Center-bearing inverted arch-bar.** 67, figs. 4957-66. See above.
- Center-block.** A center-bearing beam, which see.
- Center-block-column.** Figs. 4990-2. A column placed on top of the *center-plate block* and between it and the *center-bearing arch-bar*.
- Center-block fitch-plate.** Figs. 5086-7. See *Centre-block* and *Fitch-plates*.
- Center-body truss-rods.** Those nearest the center, when two or more body truss-rods are used under each side of a car-body.
- Center-brake-lever** (Elder brake). 9, fig. 1462. A horizontal lever placed underneath the bottom of a car-body, and attached by a fixed fulcrum in the center of the body and of the lever. It is connected to each of the brake-beams by *secondary brake-rods* attached near to the fulcrum, and to the brake-shaft on each platform by a *brake-shaft connecting-rod*.
- Center-brake-lever chain** (Elder brake). 10, fig. 1463. A chain which runs over the *center-brake-lever sheaves*, on the center brake-lever.
- Center-brake-lever sheave** (Elder brake). 11, fig. 1463. See above.
- Center-brake-lever spider.** A wrought-iron support, resembling the letter H, for the center brake-lever.
- Center-buffer follower-guide.** See combination follower-guide.
- Center buffer-spring.** Fig. 1401. See *Buffer-spring*.
- Center-buffer-spring** (Janney-Miller coupler). A spiral spring situated above the draft springs, intended for buffing purposes only.
- Center buffer-stem.** Figs. 1393-4. See *buffer-stem*.
- Center-buffer-yoke** (Janney-Miller coupler). The yoke connecting the central Miller buffer with the Janney equalizer.
- Center-counterbrace.** 165, fig. 456. A counterbrace in the body of the car between the trucks, to stiffen a compression-beam brace. See *Counterbrace*.
- Center-cross-bar** (English). See *Brake-shaft cross-bearer*.
- Center cross-beam.** A, figs. 325-7. A cross-timber framed into the two intermediate sills of a coal or ore car, to which the center doors are hung.
- Center cross-beam-cap.** B, figs. 325-7. A cap-piece to cover the *center cross-beam*.
- Center-cross-tie-timber.** Fig. 299. A cross-tie timber in the middle of a car, generally placed between the double drop doors of a gondola-car.
- The 22a of figs. 310-11 is a misnomer; the piece is a *transverse floor-timber* instead of a *center-cross tie timber*.
- Center door-hinge and stop** (English). 179, fig. 501. The center of three brass hinges securing the door to the body. The insertion of two rubber plugs into striking pieces or side wings on the hinge constitutes Cross's patent stop, which is used to prevent the door striking the outside of the body when thrown violently open. See also *Seat-rail support*.
- Center door-rail.** See *Middle door-rail*.
- Center-draft draw-bar.** 32, figs. 2382-89a. A draw-bar which is connected directly with the king-bolt of a truck. It is a style specially designed for use on the very sharp curves (of 90 and 100 ft. radius) of elevated railroads, and is confined to those lines. See *Barnes and Manhattan draft-gear*.
- Center draft-tube** (Argand lamp). A, figs. 3371-2. The hollow passage for air in the center of the burner.
- Center floor-timbers.** 4, figs. 229-66, etc. The *center-sills*, which see.
- Center-girth.** See *Door-center girth*.
- Centering-gage.** A gage to fix the middle point of an axle.
- Center-lamp.** 135, fig. 447; L, fig. 540-1, 3252-76. A lamp suspended from the center of the ceiling of a car. The term is used to distinguish *center-lamps* from *side-lamps*, the latter being attached to the sides of cars. Center-lamps having two or more burners are commonly called *chandeliers*.
2. (Pintsch-gas center-lamps, which see.) Figs. 3235-43.
- Center-piece** (air-pump of Westinghouse brake). 4, fig. 1689. An iron casting which forms the lower head of a steam-cylinder, and the upper head of an air-cylinder.
- Center-pin, or king-bolt.** 18, figs. 229-66, etc.; 16, figs. 435-72, etc. A large bolt which passes through the *center-plates* on the body-bolster and truck-bolster. The truck turns about the bolt. It normally has no strain upon it and no key or nut at the lower end. It is therefore a mere pin and not a bolt in the usual sense, but in wrecking-cars the center-pin is sometimes provided with *keys* to fasten the truck and car-body firmly together. The name king-bolt is derived from the name of the corresponding part for the front wheels of a wagon. *Center-pin*, however, is the more common term.
- Center-plate.** 15, figs. 435-73, 4626-8, 4716-23, 4979-81, and 5176-82. One of a pair of plates made of cast or malleable iron or pressed steel, which support a car-body on the center of a truck. There are two, the *body center-plate* and the *truck center-plate*, which are sometimes also called the *male* and *female* center-plates. The *center-pin* or *king-bolt*, which see, passes through them but carries none of the strain except in emergencies. See *Swinging-platform center-plate*.
- Center-plate block.** Fig. 4644. A piece of wood placed under a truck center-plate to raise it up to the proper height.
- Center-plate bolster-truss** (double iron bolster). Fig. 1921.
- Center-post** (side dump-car). 111, Figs. 332-5. A post standing on the center-sills and bolted to the *transverse filling-pieces*, and helping with other center-posts to carry longitudinal floor timber to which the planking of the inclined floor is spiked.
- Center-shaft** (hopper-bottom cars). 70, figs. 298-315. A *winding-shaft*, which see.
- Center-sills.** 4, figs. 229-66, 435-73, etc. The two main longitudinal timbers underneath the floor which are nearest the center of the car. In iron-frame cars they are usually I-beams, which see.
2. (Hand-car.) 10, figs. 5592-5600.
- Center-spring washer** (Janney coupler). The washer against which the Janney *center-buffer spring* impinges.
- Center-stay** (of a chandelier). 30, figs. 3261, 3271-76. The central support around which the lamps are grouped. In some cases it is the only method of attaching the chandelier to the ceiling, and in others there are several inclined *roof-braces* or vertical *lamp-arms* in addition. In "hurricane" or "tornado" lamps, which see, the center-stay is usually a hollow tube for the passage of air.
- Center-stem chafing-plates.** Figs. 1269-70.
- Center-stem follower.** Figs. 1385-6.
- Center-stop** (tip-car). A bracket or block attached to a draw-timber to restrain the body from moving longitudinally.
- Center suspension-lamp.** Figs. 3235-8. See *Pintsch lamps*.
- Center-truck.** Figs. 332-5. The middle one of three trucks of a car.
- Center-truck roller.** 122, figs. 332-5. A roller placed between two plates, one attached to the car-body and the

other to the *center-truck*, so that the truck can move laterally and permit the car to pass over curved track.

Center-truck roller-pedestal. 122, figs. 332-5. A pedestal with projecting horns which engage with the bosses on either side of the roller and prevent displacements.

Chafing-clip. (National hollow brake-beam.) Figs. 1627, 1629a-b.

Chafing-plate. A metal plate to resist wear, used on brake-beams, truck-transoms, swinging spring-beams, etc.

See *Brake-beam chafing-plate.* *Drawbar chafing-plate.*
Check-chain chafing-plate. *Transom chafing-plate.*
Truck-bolster chafing-plate.
Coupling-pin chafing-plate.

2. (Janney-Miller coupler.) A bar across the top of the stirrup.

Chain. "A series of links or rings connected, or fitted into one another, usually made of some kind of metal."—*Webster.*

See *Basin-chain.* *Hoisting-chain.*
Berth-chain. *Horizontal brake-shaft chain.*
Brake safety-chain. *Lock-chain.*
Brake-shaft chain. *Manhole-cover chain.*
Center brake-lever chain. *Pitch-chain.*
Check-chain. *Platform-railing chain.*
Connecting-chain. *Railing-chain.*
Coupling-chain. *Safety-coupling chain.*
Door-pin chain. *Tank-nozzle-cap chain.*
Driving-chain. *Uncoupling-chain.*
Drop-bottom chain. *Wedge-chain.*

Chain and eye (for door-bolt, postal-car fittings). Fig. 3827.

Chain-box (of a derrick). A box below the hoisting-gear for holding loose chain or rope.

Chain coupling-link. Two or more coupling-links attached together like a chain. Used with a *draw-hook*, which see.

Chain-holder (for basin-plug). Figs. 3483-4. A *stanchion*, which see, provided with screw-thread and nut for passing through the marble slab. Also called a *chain-post*, *chain stay*.

Chain-lock (for glass seals). Fig. 1016. One of the simplest forms of seal locks, relying solely for security on the protection of the seal.

Chain-post. See *Chain-holder*.

Chain-sheave. 37, figs. 2431-6. (Gould vestibule.) A restraining chain-sheave, it is attached to the *front-face plate* by a chain sheave-bracket, 36. See *Face-plate restraining-chain*.

Chain-stay. See *Chain-holder*.

Chair. Figs. 3921, 3926-7, 3977-9, 3988-92. The usual designation for the seats of parlor-cars. See *Revolving-chair.* *Hartley chair.* *Hitchcock chair.*

Chair-arm plate. A metal plate for the top of a chair-arm. If for common passenger-car seats it is called an *arm-cap*, which see.

Chair-back (Hartley chair). 9, figs. 3998-9.

Chair-car. Fig. 98. Another name for *parlor* or *drawing-room* cars, fitted with arm-chairs which are usually adjustable arm-chairs, like the *Hartley* or *Hitchcock*, when this distinctive name is used. The term *chair-car* generally is applied to a car equipped with *reclining-chairs* or *twin car-seats*, and which car is run on local night-trains so that people may rest and take cat-naps.

Chair-caster. See *Caster*.

Chair-leg caster or socket. Figs. 4112-15. A hollow casting which fits on the end of a chair-leg. Such casters, when casters proper, are provided with wheels, but frequently in car construction they are without wheels, and are then by custom of the trade still called *casters* (*fixed* or *rigid casters*), although properly not such.

Challender truss. Figs. 563-9. A substitute for the truss-plank and side body-bracing of passenger-car frames, and used on the Chicago, Burlington & Quincy Railroad.

It consists of a thin plate of iron with an angle iron riveted to the bottom and sometimes one at the top and bottom. It is fastened to each post by large wood screws, and is bolted to the side-sills. It is sometimes made to serve as a substitute for truss-rods under the car, and to form a part of the inside finish under the window. Cars trussed in this way are said to be as light and cheap as those in which the ordinary form of construction is used, but the truss has not so far found sufficient favor to be adopted as standard, not even by a few roads.

Chamber. See *Dust-guard chamber*.

Chamber-cap (Westinghouse brake). See *Right chamber-cap*.

"**Champion**" lamp-burner. Fig. 3380. One of the no-chimney burners.

Chandelier. A center-lamp having two or more burners, but generally meaning only those of very elaborate form or having more than two burners, as the two and four light chandeliers, figs. 3261-76.

Channel bar. Figs. 4661-3. A general term applied by makers to iron rolled with the following section: []. They are in use for the side-sills of iron-frame cars, for transoms and spring-planks of trucks. *I-bars*, which see, are used for inside sills of *under-frames* and for *truck-bolsters*, figs. 4664-6.

Chapel-car. Fig. 203. A car, a number of which have been built, in which church services are to be held. They have been used in the West and Northwest, where missionary work has been carried on quite actively in them. They are encouraged by the railroads, and the meetings are said to be largely attended by railroad employes.

Chaplet. A piece of iron used in a mold for casting, to hold a core in its place.

Chapman's screw-jack. Figs. 3743-4. See *Screw-jack*.

Chase refrigerator-car. Fig. 14. An ice and salt car. In each end of the car are placed cylinders, in the center of which is a pipe larger at the top than at the bottom. The cylinders are filled from the roof with broken ice. Drainage is had by a valve at the bottom of the cylinders operated by a rod running to the top.

Check-chain. 68, fig. 4942. A chain attached to a truck and the body of a car to prevent the former from swinging crosswise on the track in case of derailment. Such chains are usually attached either to two, or to each of the four corners of a truck and to the sills of the cars.

At 8th Annual Convention, Cincinnati, 1874, it was "Resolved, That truck and car-body check-chains are, when properly applied, a valuable acquisition on passenger equipment, and your committee recommend their general use." In 1893, the use of truck and car-body check-chains, properly applied, was adopted as a Recommended Practice.

A difficulty with check-chains has been that the *eyes* by which they are attached to the body and truck were not strong enough to resist the strain, and that the chains themselves have been too long to come to a bearing soon enough to have the trucks controllable.

Check-chain chafing-plate. A plate attached to a truck timber to resist the wear of a check-chain.

Check-chain eye. 70, figs. 4943 and 4938-9. See *Body check-chain eye.* *Truck check-chain eye.*

Check-chain hook. 69, figs. 4942 and 4938-9. See *Body check-chain hook.* *Truck check-chain hook.*

Check-gage for mounting wheels. Fig. 5486. The check-gage for mounting wheels shown was adopted as standard in 1894. The gage is shown as applied, in one position, to a pair of standard wheels mounted to standard distance, and it is important that such gage be universally used after September 1, 1894, in mounting wheels, in order to have them pass inspection at interchange points.

Check-valve (triple valve). 15, figs. 1706-7.

Check-valve case. 13, figs. 1706-7. See above.

Check-valve case-gasket. 14, figs. 1706-7. See above.

Check-valve spring. 12, figs. 1706-7.

Chicago & Northwestern grain-door. Figs. 1927-8.

Chicago car-coupler. Figs. 2111a-d.

Chicago grain-door. Figs. 1870-5. One of several grain-doors, which slides up and down on a grain-door rod fastened to the door-post and is hung to the carlines when not in use. The top of the door is fastened to the rods by a *ring* and a *door-arm*, fig. 1872.

"Chicago, Milwaukee & St. Paul" refrigerator-car. Figs. 278-82. The car as shown is built after the Wickes system of refrigeration, and contains Wickes ice-boxes, and was intended for fruit business and ordinary perishable freight. Salt is not used. The cars for meat business, in which salt is used, have a different style of ice-box. The dimensions of each box are 3 ft. by 3 ft. 2½ ins. by 4 ft. 10 ins. high, and the boxes are made of Nos. 20 and 24 galvanized-iron basket-work, built on oak frames. Each box has a roof hatchway, with a solid wooden cover which may be lifted partially and held in position for ventilation. In this case hatchways are covered with wire netting of 12-mesh, No. 33 brass wire. The car thus serves as a refrigerator, or as a ventilated car, as occasion requires; the ventilators are of the Earle patent.

The insulation on sides and roof-lining is as follows: Outside sheathing, layer of Neponset insulating paper, air space, ½-in. lining, Neponset paper, ¾-in. hair felt, air space with furring strip spacings, Neponset paper, inside lining.

Data not given in the figures are as follows:

Length inside lining	33 ft. 1¼ ins.
Width inside lining	8 ft. 1¼ ins.
Length between ice-boxes	24 ft. 2 ins.
Height, rail to top of running-board	12 ft. 11¼ ins.
Height, rail to top of brake-staff	13 ft. 8¼ ins.
Capacity of ice-tanks	7,500 lbs.
Average weight of car-body	26,100 lbs.
Average weight per pair of trucks	11,320 lbs.
Total weight of empty car	37,420 lbs.

Chicago, Milwaukee & St. Paul system of direct steam-heating. Figs. 3056-7.

Chicago sectional-corrugated car-roof. Figs. 2368-78. See *car-roofs*.

Chill. A kind of crystallization produced when melted cast-iron is cooled suddenly. It is usually accomplished by bringing the molten iron in contact with a cold metal (usually iron) mold. The hardened part of a car-wheel is called the *chill*. The mold in which a chill is produced is sometimes called a *chill*, but the name *chill-mold* has been given to this. Chilling was invented in Philadelphia in 1847. The name of the inventor is not known. The process was never patented. All cast-iron railroad car-wheels are chilled wheels.

Many wheels are now chilled in what are termed contracting chills, Figs. 5364-73, which are made in such form that the heat from the molten metal automatically keeps the chilling surface (in contact with the wheel-tread) very nearly a uniform size and shape; even though the mold does expand as a whole. The chilling surface may even contract to less than its normal size. The result of this, it is claimed, is to give a deeper and more uniform chill and a more perfect wheel. This contraction is accomplished by cutting the chilling surface into radially divided segmental blocks which are connected to the mold by radial arms. These radial arms are several inches long and are of less cross-section than the segmental blocks. When molten metal is poured against the segmental chilling-blocks, the heat travels by conduction to the radial arms which expand in the direction of their radial lengths and thus crowd the segmental blocks in toward the center of the wheel, contracting its size; hence the name *contracting chill*.

There are three types of chills in general use. The Whitney, figs. 5374-6; the Barr, figs. 5364-7; and the Canda, figs. 5368-73. The Whitney contracting chill was first invented and patented in 1886 by John R. Whitney, of Philadelphia. The Barr chill is alternately heated and

cooled by forcing currents of steam and cold water through the periphery of the chill to keep it normal so as to intensify the contraction. In the Canda chill the mold is made up of three rings with the alternate segmental chilling-block joined successively to the two upper rings and the two lower rings.

Different kinds of iron have the property of chilling in different degrees, and the different kinds are mixed frequently to secure the best results. There are numerous theories advanced to explain and describe the phenomena, for which see the scientific books on metallurgy.

Chill-crack. An irregular crack developed in casting upon the chilled surface of the tread of car-wheels. Chill-cracks not over ¼ in. wide, and not extending to the flange, are not considered as injuring the wheel or as indicating weakness or inferior quality. Iron which makes the most durable car-wheels is most liable to chill-cracks. See *Wheel specifications. Interchange of Traffic*.

Chimney (for lamps). Figs. 3412-22. See *Lamp-chimney* for table of standard dimensions.

See also *Globe-chim-*

ney.
Lamp-case chimney.

Lamp-globe chimney.

Smoke-pipe.

Stove-pipe.

Chimney-holder and reflector combined. Fig. 3436.

Chipping (of chilled car-wheels). A scaling off of small portions of the chilled metal, due to imperfect or irregular crystallization. Wheels chipped on the tread to a depth of more than ½ in. or leaving the tread less than ¾ in., are rejected under rules for interchange of car. See *Interchange of Traffic*.

Chock or chock-piece (snowplow framing). Figs. 408-9. In shipbuilding a wedge or triangular-shaped block or timber used to unite the head and heel of consecutive timbers: *Century*. Also intended as a filling-piece to give form or shape. Hence in a snow-plow a timber which joins successive timbers, and fills out to give shape, as shown.

Chord (of a truss). The long horizontal members at top and bottom of a truss. The side-sills and plates of a car-body are top and bottom chords of the side trusses. but the terms are not used in car-building. In England the chords are termed *booms*.

Christie brake-shoe and head. Figs. 1656-7. One of the many forms of this detail in which combined strength and convenience of removal have been sought. See *Brake-block*.

Church-car. See *Chapel-car*.

Chute (Baker heater). Fig. 2870. The interior frame of the feed-door forming a passage for the fuel.

Cigar-holders. Figs. 4277, 4282.

Circulating-drum (Baker heater). Figs. 2893, 2902-3. A cast-iron vessel with hemispherical ends, on top or inside of the car, filled with water, and connected by two pipes with the *coil* in the stove and with the pipes which extend through the car. As the water in the coil becomes heated it ascends to the drum, and from there it descends through the other pipe to the *radiating pipes* in the car. After passing through them it is brought back by return pipes to the coil, when it is again heated. Thus a continuous circulation is kept up. It is also called the *expansion-drum*. There are several styles, among them the *upright*, fig. 2902; the *horizontal*, figs. 2903, 2893, etc.

Circulating pipes (Baker and other heaters). Figs. 2957 and 2959. A general name for the pipes which carry the steam or other heated fluid through the car and return it again to the heater. The term *radiating pipes* is also used.

Circular tail-light. Fig. 3362. See *Signal-light*.

Circumference measure (M. C. B. Standard). Figs. 5422-3. A steel tape-measure specially designed to measure the circumference of car-wheels.

Clamp. 1. "In general, something that fastens or binds

a piece of timber or of iron used to fasten work together."—*Webster*.

2. (Joinery.) "A frame with two tightening screws, by which two portions of an article are tightly compressed together, either while being formed or while their glue joint is drying."—*Knight*. See *Deck-sash quadrant clamp*. *Deck-sash pivot clamp*. *Platform-timber clamp*. *Ridge-clamp*.

Clasp. Fig. 3827. See *Door-bolt clasp*.

Clay car-seal. Fig. 3893. A seal made of a wire hooked at the ends into a piece of burnt clay in such a manner that it can be unfastened without breaking the clay-seal.

Clearance (of track gage). The total difference between the gage of the rails and the gage of the exterior bearing surface of the flanges is at present fixed at about $\frac{3}{8}$ of an inch, as adopted in June, 1894. See figs. 5421, 5485-6. The method of testing wheels for this purpose has been by measuring the distance in the clear from inside to inside of car-wheel. By resolution of the Master Car-builders' Association, 1883, the standard distance, fig. 5421, for flanges was fixed at 4 ft. 5 $\frac{3}{8}$ in. The limit of $\frac{1}{8}$ in. either way from 4 ft. 5 $\frac{3}{8}$ in. was adopted in 1885. In 1894 a standard check-gage for mounting wheels was adopted (see fig. 5486) which is intended to make the clearance of flanges a fixed distance. The relation of wheel-gage to track and guard-rails is shown in fig. 5485.

Clearance-car. Fig. 215-16. A car with a light frame built out on all sides to the extreme width and height required for any car that is to pass over the road. It is run over the road first to ascertain if the car can with safety be sent over the road. The car shown may also be used to ascertain what is the maximum cross-section of tunnels, bridges, etc., over a road so that cars can be built within the limits determined by the car.

Clear-story. 110-11, figs. 435-73. An upper story or row of windows in a church, tower, or other erection, rising clear above the adjoining parts of the building,"—*Webster*. Also spelled *clere-story*.

Hence, the portion of a passenger-car roof which rises above the roof proper, in the manner which is now customary in nearly all American passenger cars, has been termed the clear-story, and this name was exclusively used in the former edition of this dictionary. Since the issuing of the first edition the use of the term *deck* for clear-story seems to have become practically universal among car-builders and manufacturers, especially in compound words. Those manufacturers consulted have unanimously replied that they used no other term than *deck*, and that they do not find the term clear-story used in the letters received from railroad officers. Therefore the term *deck* or *upper deck*, which see, has been exclusively used in this edition in designating the various furnishings and parts of the framing formerly designated clear-story, as *deck sill*, *deck sash*, *deck-sash opener*, etc., for *clear-story sill*, *clear-story window*, *clear-story window opener*. As a general name for designating the entire space included within the upper deck, however, the term *clear-story* is frequently used.

The clear-story was first used in American car-framing about 1860. Certain forms of cars, as figs. 95-6, have no clear-story. The part corresponding to a clear-story in freight cabooses, figs. 50-4, 81-4, is termed a *lookout*.

Cleat. "1. A narrow strip of wood nailed on in joinery.

2. A term applied to small wooden projections in tackle to fasten ropes by."—*Webster*.

Cleveland Turnbuckle. Fig. 3727a. See *Turnbuckle*.

Clevis. "A stirrup-shaped metallic strap used in connection with a pin to connect a draft-chain or tree to a plow or other tool."—*Knight*. The term is applied to various kinds of irons resembling a plow-clevis in shape, and also to bolts with forked ends. See *Boom-cap clevis*. *Brake-lever clevis*. *Draw-clevis*. *Hoisting-block clevis*.

2. (Of padlock.) 7, figs. 2766-7. The means for attaching the guard-chain which prevents carrying off the padlock when unlocked.

3. (Of pile-driving hammer.) 2, figs. 401-4. See *Hammer*.

Clevis-hook (of "American" tender-brake). The connection of the brake-chain to the brake-lever.

Clinch nail. A wrought-iron forged nail, so named because it can be bent or clinched without breaking. *Cnt*

nails, the common and cheapest kind, although of wrought-iron, will not clinch.

Clip. A U-shaped strap for attaching any body, more particularly a pipe, to the side of a partition. See *Berth-spring clip*. *Deck-sash-quadrant clip*. *Pipe-clip*.

Closed car. Figs. 5642-6. Generally a car with end doors, and the sides closed by the car panels or sheathing, and windows, so that the passengers are protected from the wind and weather.

The term is used for a winter car to distinguish it from an *open* or *summer-car*, in which the seats are usually transverse to the car, the sides open, except for curtains as shown in fig. 5649.

Closed-door stop (freight-car doors). 72, figs. 229-66, 355-72. A block of wood or iron to prevent outside sliding-doors from moving too far when they are closed. See also *Open-door stop*.

Close return-bend. Fig. 2945. A short cast-iron tube made of a U-shape, for uniting the ends of two wrought-iron pipes. It differs from an *open-return bend* in having the two branches in contact with each other.

Closet. 1. A small room, usually for storage. See *Linen-closet*, *Wine-closet*, etc., figs. 432-4. A *locker* is a closet of less than the full height of car, but this distinction is not always observed.

2. A retiring-room for sanitary purposes, more commonly called a *saloon*, which see.

Closet-hopper. Figs. 3854-68; 131, figs. 439, 448. Also called *soil-hopper*. A metal or porcelain hopper used in saloons.

Closet-hopper ventilator. Figs. 3841-2. See *Bell's exhaust hopper-ventilator*.

Club-car. Figs. 161-2. A buffet-parlor car built and owned by railroad companies but kept expressly as a private car for members of a club, which members live in the suburbs of a large city. The car makes such trips each day as suit the convenience of the club members, and none others ride in the car.

Clutch-coupling. See *Brake-hose coupling*.

Clusters (Pintsch lamps). The four-flame cluster, No. 227 (fig. 3209) is the one ordinarily used in center-lamps. Where a large amount of light is required, as in compartments having but one lamp, five or six flame clusters (Nos. 228, 229) may be used. Where a small amount is needed, as in central corridors at ends of cars, two-flame clusters, No. 226, may be used.

For vestibule lamps, No. 194 (fig. 3239), the two-flame cluster, No. 226A (fig. 3210), is required. Four-flame vestibule lamps, No. 195 (fig. 3241), use the ordinary four-flame cluster, No. 227.

All clusters are provided with check screws, placed at the base of the burner arm, by means of which the flow of gas to each burner can be regulated. These check screws are locked in place by small nuts.

Cluster-spring. Fig. 5221. A *group-spring*. See *Spiral-spring*.

Coach. Figs. 89-96, 155-9, 419-460. A term used to designate cars for the conveyance of passengers, in distinction from freight, baggage, and express cars. The term was originally proposed by John B. Jervis. See "Railway Property," page 178. By increasing usage the term is used as an equivalent for *day-car* in distinction from sleeping-cars as well as freight and baggage cars, but "sleeping coach" is a common expression.

Coach-bolt (English). American equivalent, *carriage-bolt*, which see.

Coach-screw (English). American equivalent, *lag-screw*, but *coach-screw* is also used. A square-headed screw with a pointed end used to screw into wood.

Coal-box. A box for carrying coal. It is usually a long narrow deep box, placed between the heater and the end of the coach.

Coal-car. Figs. 22-26, 65-72, and 298-324. A car especially designed for carrying coal. The standard cars built for

coal service to-day are largely what are termed *gondolas*. They are from 27 to 36 feet long and carry 60,000 lbs. They are usually designated by the character of the dumping devices applied; as, *Drop-bottom*, *Hopper-bottom*, *Box hopper-bottom*, *Pyramidal hopper-bottom*, *Twin hopper-bottom*, etc. Four-wheeled coal-cars are discarded as rapidly as they are worn out, and being replaced by 60,000 lb.-gondolas with hopper- and drop-bottoms.

Where railroads have a large lumber business, the drop-bottom cars like figs. 298-304 are in favor in preference to figs. 305-320.

See *Eight-wheeled car.* *Hopper-bottom car.*
Four-wheeled car. *Twin hopper-car.*
Drop-bottom car.

Coal-hopper. See above and *Hopper*.

Coal-oil burner. See *Mineral-oil burner*. Figs. 3363-97.

Coat-and-hat-hook. Figs. 3666-92.

Coat-hook. Figs. 3688-92.

Cobb's Elliptic seat-springs. 1. H. B. Cobb's *broad-band elliptic seat-springs*, fig. 4004. 2. Z. Cobb's narrow-band elliptic seat-springs, figs. 4003. The difference is shown in the illustrations.

Cobb's pivoted seat-arm. Fig. 4093. A device by which the seat-arm is hinged at the seat-back by *swing-joint* so that in reversing the back is raised up, making a narrow 22-inch seat-back give as high a support to the back as a 28-inch seat-back hung in the ordinary manner. Also called Cobb's *striker-arm*, which see.

Cobb's sectional seat-cushion. Figs. 403-4. See *Seat-cushion*.

Cock. 4 and 6, figs. 3525-7, and 3489-94. "A spout; an instrument to draw out or discharge liquor from a cask, vat, or pipe."—*Webster*. See *Faucet* for the various forms; also

<i>Bibb-cock.</i>	<i>Release-cock.</i>
<i>Combination-cock.</i>	<i>Reservoir drain-cock.</i>
<i>Compression faucet.</i>	<i>Self-closing cock.</i>
<i>Drain-cock.</i>	<i>Stop-cock.</i>
<i>Draw-off cock.</i>	<i>Telegraph-cock.</i>
<i>Four-way-cock plug.</i>	<i>Three-way cock.</i>
<i>Main-cock.</i>	<i>Vertical telegraph-cock.</i>

Cocoa matting. Matting for the floors of cars made from the *coir-fiber*, growing in East India and the east coast of Africa.

Coil (Baker heater). Figs. 2874, 2894, 2906-7, 2919-20. (Gold car-heating) figs. 3002-3, 3006. An iron pipe which is bent in a spiral form and placed in the fire, for heating water which circulates through the car.

Coil-jacket steam heating system (one of the Safety's car-heating systems). Figs. 3024-7. This system is primarily a system devised to meet the requirements of those who demand that all the jackets and circulation piping be retained entirely within the car. The principle is the same as indicated under the head of *Standard Systems*. The jackets are shown in figs. 3025-26, and in figs. 3043-5; and in these the circulating water is heated by steam from the locomotive. See *Safety's Car Heating Co.'s Systems of Car-heating*.

Coke-car. Fig. 21. A gondola or flat car with extra high sides or a rack, made necessary by the light character of the load. Box-cars are often used as coke-cars.

Coke-rack stake-pocket. 39a, figs. 310-15. A stake-pocket fastened to the side or end planks of a gondola-car which are to take the stakes of a coke-rack.

Cold-air pipe (Spear heater). Figs. 3058-60. A pipe by which cold air is conducted from a hood on top of the car to the bottom of the stove, and into the air-space between the stove and the stove casing.

2. (Pullman system of heating and ventilating.) Fig. 4029. A pipe extending to the roof and surmounted with a funnel-shaped wind scoop, through which the cold air is forced by the motion of the car down into boxes surrounding the hot-water pipes. The heated air escapes to the car through a register in the end of the seats.

Cold-shot. Small globules of iron resembling ordinary gun-shot, which are found in the chilled portion of cast-iron wheels.

Collar. 1. "A ring or round flange upon or against an object."—*Knight*. Ordinarily an *axle-collar*, below, is meant.

See <i>Deck-collar.</i>	<i>Lamp-collar.</i>
<i>Dust-collar.</i>	<i>Reducing-collar.</i>
<i>Expanding-collar.</i>	

2. (Of journal.) Fig. 5420. A rim or enlargement on the end of the car-axle which takes the end-thrust of the *journal-bearing*. A *muley axle* has no collar.

Collins brake-head. Fig. 1616. The shoe is fastened by a dove-tail, which is wedge-shaped.

Color-coat (painting). The coats which follow the *rough-stuff* or scraping filling-coat in painting passenger car-bodies. It is applied before the lettering and striping. The colors are mixed with turpentine and dryers, as little oil as possible being used, only sufficient to prevent the color from rubbing off. Twenty-four hours are allowed to each coat to dry, and the processes of lettering, striping, and varnishing then follow, which vary greatly in the time and care given to them, but which are always very carefully done. See *Finishing varnish* and *Painting*.

Columbian deck-ceiling. Figs. 107, 109, 116-7, 122, 126, 130, 133. A style of interior finish and decoration introduced first by the Pullman Palace Car Company, and exhibited at the World's Columbian Exposition in 1893. It consists of an arched-deck ceiling divided up by prominent ribs, elliptical arched-deck windows, whose arches groin with the deck ceiling as in figs. 122, 126, and produce a very pleasing effect.

Column. 1. (Diamond and other trucks.) 37, figs. 4580-4805. Another and perhaps more common name for a *Bolster guide-bar*, which see.

2. (Of crane.) Another name for the *mast*, especially when entirely supported from below.

3. (Hartley chair.) 12, figs. 3998-9. See *Pedestal*.

Column-bolt. 109, figs. 4580-4805. A bolt passing through the arch-bars and holding the column in place and the truck-frame together.

Comb-and-brush rack or case. Figs. 3510-24.

Combination. An adjective often prefixed to the parts of the Janney-Miller combination coupler. The parts in the following list are designated sometimes with and sometimes without the prefix "combination." See *Janney-Miller coupler* and the names of the several parts, omitting the word "combination."

<i>Combination ball-joint washer.</i>	
<i>Combination barrel.</i> The barrel or shank to which the <i>Janney head</i> or <i>Miller hook</i> is secured.	
<i>Combination chafing-plate.</i>	<i>Combination connecting-pin.</i>
<i>Combination face-plate.</i>	<i>Combination eye-bolt</i> (for <i>Miller hook</i>).
<i>Combination follower.</i>	
<i>Combination follower-guides</i> (right and left).	
<i>Combination head</i> (<i>Janney-Miller coupler</i>). A head for the <i>Janney coupler</i> substantially similar to the ordinary form, but adapted for use in the <i>Janney-Miller combination coupler</i> .	
<i>Combination horn.</i>	<i>Combination Janney barrel.</i>
<i>Combination Janney head.</i>	<i>Combination large equalizing-guides</i> (right and left).
<i>Combination lever jaw-pin.</i>	<i>Combination Miller buffer-yoke.</i>
<i>Combination Miller buffer.</i>	<i>Combination Miller stop.</i>
<i>Combination Miller head.</i>	<i>Combination platform-lever jaw.</i>
<i>Combination Miller stop-bolt.</i>	<i>Combination open link for Miller hook.</i>
<i>Combination platform-lever plate.</i>	<i>Combination pull-rod.</i>
<i>Combination platform-lever.</i>	<i>Combination side-spring bolt.</i>
<i>Combination side-spring.</i>	<i>Combination clevis.</i>
<i>Combination side-spring bolt-pin.</i>	<i>Combination side-spring eye-bolts</i> (long and short).
<i>Combination side-spring plate.</i>	<i>Combination side-spring stirrup.</i>
<i>Combination side-spring plate-washer.</i>	<i>Combination side-spring trigger.</i>
<i>Combination side-spring washer.</i>	<i>Combination small equalizing-guide.</i>
<i>Combination stirrup.</i>	<i>Combination swivel.</i>
<i>Combination swivel-hook.</i>	<i>Combination trap-door.</i>
<i>Combination trap-door spring.</i>	<i>Combination yoke, Janney.</i>
<i>Combination yoke-bolt, Janney.</i>	

Combination baggage-car. Figs. 136-7, 596-7. A baggage-car having compartments for express or mail, or both, as well as for baggage. See *Combination-car*.

Combination-car. Figs. 132-6, 138, 444-52, 468-73. A passenger-car, one portion of which is devoted to passengers

- and the other to the conveyance of mail, baggage, or express. A *combination baggage-car*, which see, is also a combination-car.
- Combination cock.** Figs. 2914, 2933. (For Baker heater.) A cock with funnel attached, used at the top of a tank for filling. When opened with the key it allows the inward passage of the water, and at the same time the outward passage of air through a separate channel. Hence the name.
- Combination follower-guides** (Janney-Miller Coupler). Two guides (R. & L.) bolted to the principal platform timbers and which guide the centre buffer-spring follower.
- Combination hand-cars.** Figs. 5583-4, 5589-90. A car so constructed that the propelling levers or walking-beam can be removed and the car used as a *larry* or *push-car*.
- Combination hot-and-cold water-faucets.** 6, figs. 3525-7, and figs. 3494, 3528.
- Combined label-holder and drawer-pull.** Fig. 3029-30.
- Combined reflector and chimney-holder.** Fig. 3436.
- Combined triple-valve, reservoir, and brake-cylinder** (Westinghouse freight-brake). Figs. 1728-9. To lessen the complication and reduce the cost of freight brake-gear these three parts, which are separate in passenger brake-gear, are combined in freight.
- Commingler storage-system of car-heating** (Consolidated Car-Heating Co.). Figs. 2973-74. A small *commingler* is placed under the middle seats on each side of the car, between the floor of the car and the deafening-ceiling. The outflow connection of this commingler is the side piping, and the other end, forming the return, is connected with a valve, and thence into the base of the commingler. A complete circuit is thus established, through which a continuous flow of water may take place, as shown by the arrows. The overflow, through which surplus water is removed from the system, is connected with the fitting, which is placed at the highest point in the system, 3K. When the pipes are entirely filled, the surplus water flows from this fitting through the restricted opening in the trap-cock, and thence down through the channel-way, 3A, cast in the base of the commingler, and out at the drip-pipe. The connection of the overflow-pipe to the base of the commingler is made to prevent possibility of freezing of the drip-pipe in cold weather. When the pipes are filled with water of condensation, all surplus is carried off through the overflow-pipe. The entire system is quickly emptied of water, and the car is then ready to stand out in the cold without danger of freezing, and it is also ready to be quickly heated by direct steam when again brought into service.
- Commingler-system of car-heating.** Figs. 2969-74. See *McElroy commingler system*.
- Commode-handle** (English). 177, fig. 501. Nearest American equivalent, *body hand-rail*. A piece of brass or iron secured to the sides of the body, and shaped so as to be conveniently grasped by the hand in entering and leaving carriage or in passing along the train outside the carriages.
- Communication-cord pulley** (English). 170, figs. 501-4. American equivalent, *bell-cord pulley*. A small brass pulley fixed to the eave of the roof and carrying the *communication-cord* (bell-cord) running outside the train.
- Compartment** (English and American). Figs. 176, 187, 205, and 501-4. A subdivision of a passenger-car. In English carriages it runs entirely across the car. In American parlor and sleeping-cars, in which alone compartments often occur, it runs only partially across, leaving room for a passage or *corridor* at the side. Often called *staterooms*.
- Compartment sleeping-car.** Figs. 123, 176, 187. A sleeping-car which is divided up into staterooms all opening into a common *corridor* which runs the whole length of car. See *Sleeping-car*.
- Composite carriage, or composite** (English). A coach in which compartments for more than one class of passengers are provided. A compartment for baggage is generally included.
- Composite end-framing.** Figs. 523-30. A type of framing adopted by the Wagner Palace Car Company and by the Vanderbilt system of railroads, which combines iron and wood, in the sills, posts, plates, etc. The *sills* and *plates* of the body and deck consist of two pieces of wood with an iron or steel fitch-plate between, the three pieces being bolted together as one. To these iron fitch-plates and mortised into the wood fitch-planks of the sills and plates are bolted or riveted upright iron posts. These iron posts are also sandwiched between wood studs making a composite post of great stiffness and strength. The end plate is also strengthened in the same manner, as are all the important members of the car-body frame.
- Composite end-post.** C, figs. 529-30. See *Composite end-framing*.
- Compound-bolster.** Fig. 1428-30. A bolster composed of one or more sticks of timber stiffened with vertical plates of iron.
- Compound-carline.** 100, figs. 435-73. A carline of which the main or central portion is made of wrought-iron, with a piece of wood on each side. They are commonly used for cars with clear-stories, and either extend directly from one plate to the other, or are bent to conform to the shape of the clear-story. In the latter case they are called *profile-carlines*. See *Carline*.
- Compression-bar.** See *Body-bolster compression-bar*.
- Compression-beam.** 163, fig. 456. A horizontal timber in the center of the side of a car-body, which acts as the compression-member of a truss for strengthening the body. The *compression-beam-brace* abuts against it. An *end compression-beam* is sometimes used. The compression-beam is sometimes made double, one above the other, with separate *braces* (*main compression-brace* and *center compression-brace*) acting upon each.
- Compression-beam brace.** 164, fig. 456. A brace used in connection with a compression-beam to form a truss in the side of a passenger-car. It is sometimes stiffened by a *center-counterbrace*, 165; and sometimes two or more braces are used, as in fig. 456. It is then termed *main compression-brace*.
- Compression-faucet.** Fig. 3485 and 4, figs. 3525-7. A spring faucet with a flat disk on top, letting on the water by direct vertical compression. *Telegraph-cocks*, which see, are in a sense compression-faucets, but are not so called.
- Compression-member.** Any bar, beam, brace, etc., which is subjected to strains of compression, and forms part of a frame truss, beam, girder, etc. *Struts*, *body-braces*, etc., are *compression-members*. Similarly a *tension-member* is used for tensile strains.
- Compression-rod brake.** Fig. 1458. An inner-hung brake with a single lever, which is connected with a brake-beam farthest from it by a rod or bar which is subjected to a strain of compression when the brakes are applied. The pressure on the brake-blocks is not equal.
- Compromise-wheel.** A *broad-tread wheel*, which see, for running over slightly different gages. Little used.
- Concave elliptic spring.** Fig. 5233. A style of spring in which the plates are dished or concave, with the object of stiffening the plates, holding them more firmly in their relative positions, and throwing the edges of the plates wholly into compression so as to diminish the danger of fracture by the gradual development of cracks.
- Concealing urinal.** One designed to be opened for use by a handle at the top, and then closed up flush with the wood-work so to be invisible. They are in limited use, but not generally approved.
- Concealing water-closet.** A form of closet covered with a seat to resemble an ordinary chair or sofa.
- Condensing diaphragm** (refrigerator-cars). Sheets of

- metal placed in the cold-air flue on which moisture may be precipitated.
- Conductor** (refrigerator-car.) The drip-pipe from the ice-pan. See also *Heat-conductor*.
- Conductor's car.** Figs. 50-4. A *caboose-car*, which see.
- Conductor's lantern.** Figs. 3352-60. One with an extra sized *bail* attached to it by which it can be held on the arm, leaving the hands free. It is sometimes provided with a *reflector*. They are often elaborately finished and sometimes bear the name of the conductor cut on the globe.
- Concave-panel corner-iron** (street-car). 52, figs. 5656, etc.
- Conductor's-valve.** (Westinghouse brake). 22, figs. 1693-8. A valve for applying the train brakes placed at some convenient point in a car, usually in the saloon, and operated by a cord extending through the train within reach of the conductor.
- Conductor's-valve discharge-pipe** (Westinghouse brake). A pipe leading from the conductor's valve down through the floor of the car.
- Conductor's-valve pipe** (Westinghouse brake). 23, figs. 1693-8. Connects the brake-pipe with the conductor's-valve.
- Cone.** 1. (For berth-spring.) A *berth-spring fusee*, which see.
2. (Graduated bolster-spring.) Fig. 5218. A projecting sleeve on the spring-plates to serve as guides or distance for the springs. They are distinguished as *lower* and *upper*.
- Cone-and-apron ventilator.** Fig. A303. See *Ventilators*.
- Cone-cap ventilator.** Fig. 4302. See *Ventilators*.
- Cone lamp-shades.** Figs. 3423-5. See *Lamp-shade*.
- Coned closet-hopper.** Figs. 3866-7. See *Closet-hopper*.
- Congdon brake-shoe.** Figs. 1656-7. A brake-shoe invented and patented by Mr. J. H. Congdon, then Master of Machinery of the Union Pacific Railroad. The patent has expired. It consists of a cast-iron shoe with 7 pieces of wrought-iron cast in it in the face or rubbing surface so as to give it greater endurance. See *Brake-shoe*.
- Connecting chain** (pile-driver car and steam shovel). 44, fig. 402, and 18a, fig. 405. A *pitch-chain*, which see, connecting the *pitch-gear* on the two axles of a truck used for making the car self-propelling.
- Connecting-pin** (Janney-Miller coupler). The steel pin securing either the *Janney head* or the *Miller hook* to the shank of the Janney-Miller combination coupler.
- Connecting-rail.** 48, figs. 3917-25. The wood or metallic bars that join the wall and aisle ends of a seat.
- Connecting-rod.** 1. A rod which connects two or more parts or objects together. See *Brake-shaft connecting-rod*. *Floating-lever connecting-rod*. *Car-seat connecting-rod*.
2. (Hand-car.) 24, figs. 5592-5600. The iron rod which connects the *bell-crank* and the *crank-shaft* together.
- Consolidated car-heating systems.** Figs. 2959-95. Several systems of car heating including a *Direct-steam system*, a *Direct-steam storage-system*, a *Multiple-circuit drum-system*, the *McElroy commingler system*, and the *Commingler storage-system*, all of which see.
- Continuous basket-rack.** Figs. 98, 3756-8. See *Basket-rack*.
- Continuous brake.** A system of brakes so arranged that by connecting together the brake apparatus on the different vehicles forming a train it can be operated on all of them from one or more points on the train, as from the engine or from any of the cars.
See *Air-brake*. *New York air-brake*.
Eames vacuum-brake. *Westinghouse Automatic air-brake*.
- Continuous carline.** A *carline*, which see, which passes directly from side to side of the car, across and under the clear-story or upper deck, in distinction from a *profile carline*, which is bent to follow the outline of the clear-story.
- Continuous counterbrace-rod.** The body counterbrace-rods are sometimes combined into one long rod passing from one end of the car to the other, as in fig. 532, which is then sometimes termed a *continuous counterbrace-rod*; also, *overhang truss-rod*, *inverted truss-rod*, or *hog-chain rod*.
- Continuous drawbar.** A draft-gear, having a continuous rod or rods extending throughout the length of the car from the drawbar at one end to the drawbar at the other end, whose office is to transmit the tractive strains and relieve the draft-timbers. The *American*, figs. 1940-58, and *Wadley*, figs. 1936-9, are types most frequently met.
- Continuous-frame truck.** A car-truck with an iron frame, the sides and ends of which are all made in one piece. It is a type of truck largely in use on the Boston & Albany road, but which is no longer standard on any road. It was a truck equipped with pedestals.
- Continuous top-side** (English). 69, fig. 350-1. Nearest American equivalent, *top-side rail*. A side-board run continuously from end to end of a wagon in order to stiffen it vertically and assist in tying the ends together.
- Continuous truck-frame.** An iron bar which is welded together in a rectangular shape so as to form the sides and ends of a truck-frame.
- Contracting-chill.** See *Chill*.
- Cook-stoves.** See *Ranges*. *Caboose stoves*.
- Cope.** The upper portion of a mold or flask used in making metal castings.
- Coping** (English). 74, figs. 348-51. A bar of iron secured to the top of the sides and ends of a *gondola-car* (*open wagon*), and protecting them from local distortion and the friction of a chain or any heavy body.
- Corbeled shelf.** 2, figs. 2452-3a. Also in figs. 107 and 109.
- Cord.** "A string or small rope composed of several strands twisted together."—*Webster*. See *Hat-cord*, *Window-curtain cord*, neither of which is used, however, to any appreciable extent.
- Cording lead-seal.** Figs. 3891-a. It is used to seal up the cords by which bags are tied, used largely on bags of coffee when put in bond.
- Cord-lever** (of car-signal valve, Westinghouse train-signal apparatus, which see). Fig. 2402. The lever by which a pull on the signal-cord actuates the valve.
- Cork wall** (refrigerator-cars). Fig. 279. One of the means of insulation.
- Corner angle-post.** F, figs. 514-15. A corner-post which consists of an angle-bar, usually in combination with a wooden-post.
- Corner-brace** (street-car). D, fig. 5660. A diagonal floor timber between the *end-sill* and *Transverse floor timber*.
- Corner-casting.** A *knee-iron*, or a *corner-plate*, which see. See also *Roof corner-casting*.
- Corner-handle,** more commonly a *hand-hold* or a *grab-iron*, which see. 102, figs. 229-66.
- Corner pillar** (English). 94, figs. 501-4. American equivalent, *corner-post*. An upright piece at the corners of the body.
- Corner-plate.** 1. (Freight-car bodies.) 55, 56, 57, figs. 229-66. A wrought or cast iron angle-plate or knee on the outside corner, to strengthen and protect the frame. There are usually three corner-plates, *upper*, *lower*, and *middle*. Very commonly a *Push-pole corner-iron* or *Push-block*. 191, figs. 229-66, is cast upon the lower corner-plate.
2. (Pullman end-framing.) An angle-iron applied to the corner of a stick of timber (the *deck end-plate*) to keep it from abrasion and to strengthen it.
- Corner-post.** 1. 43, figs. 229-66; 61, figs. 435-73. The upright stick which forms the corner of the frame of a car-body.
- Corner-post ornament.** An ornamental casting on the outside corner of a passenger-car. Modern cars are not so ornamented.

Corner-post knee-iron. 1. **E**, figs. 514-15. (Pullman end-framing.) An angle-brace used to connect the foot of the *corner angle-post* to the side sill.

2. (Barr wing-vestibule and Pullman extended-vestibule.) An angle-brace for the outside corner-post of a vestibule resting upon the *platform end-sill*.

Corner-post grab-handle (street-car). **30**, figs. 5654-67; fig. 3821.

Corner-post pocket. **45**, figs. 229-66. See *Pocket*.

Corner-post strap (street-car). **29**, figs. 5654-67.

Corner-seat. A seat for the corner of a car, the back of which is not reversible. They are called *left-hand* or *right-hand*, as for a person sitting in them.

Corner seat-end. A seat-end bracket secured to the wall of a passenger-car for supporting the outer end of a *corner-seat*, which see.

Corner transom-muntin or mullion (street-cars). **176**, fig. 5662. A side mullion in the transom-frame of an open car, to distinguish it from the *center transom-muntin*, **177**.

Corner-urinal. Figs. 3874-6. So called in distinction from a side-urinal.

Corner urinal-handle. Fig. 3847. See above and *Urinal-handle*.

Cornice. **93** and **94**, figs. 435-73. The moldings at the eaves of the roof outside of a car, and where the ceiling joins the sides and ends of the car inside. There is, therefore, an *inside* and *outside cornice*. See also *Deck inside-cornice*, *Window-cornice*, etc.

Corridor (sleeping and compartment cars). Figs. **176**, **187**, **193**, and **204-5**. A passage running at one side of a car from one door to the other, affording access to the compartments. The Mann Boudoir cars are the only American cars having corridors for the whole length of the car, it being the later practice to have the corridor on different sides for the two halves of the car as in fig. 187. All sleeping, dining, and private cars have longer or shorter corridors to pass the staterooms, smoking-compartments, etc.

Corridor-carriage (English). A passenger vehicle having a passage from end to end along one side, the various compartments having doors which open into this passage. Little used. See also *Carriage*.

Corrugated car-wheel. See *Car-wheel*.

Corrugated copper tubes (Consolidated car-heating). Figs. 2977-8. Tubes used in the systems of heating in which the heat of steam is transferred from the copper tube to the water. These tubes are extra heavy and will stand 800 pounds pressure. They are good conductors of heat and allow a longitudinal compression or extension not belonging to iron pipe. They present a broken surface to the flow of water, causing the water to circulate more and to come in contact with the heated surface. These are used altogether in the Consolidated Multiple-Circuit system.

Corrugated key (*Yale lock*, which see).

Corrugated-metal car-roof (freight-cars). Figs. 2368-78. A roof consisting of iron, steel, or zinc plates covered with boards, and resting on *roof-strips* on top of the rafters and carlines. See also *Car-roof*.

Corrugated moldings. See *Waved moldings*.

Corrugated-rubber floor-mat. So called in distinction from *perforated-rubber floor-mats*.

Corrugated-steel grain-door. Figs. 1929-35. A steel grain-door which swings to one side on end when not in use, and is held from tipping over laterally by a rod.

Corrugated steel-wheel (hand-car). See *Buda corrugated steel-wheel*.

Corrugated Yale lock. See *Yale lock*.

Cosper's metallic weather-strips. Figs. 4540-1. See *Weather-strips*.

Corticine. A form of floor covering much like *linoleum*, which see, composed of linseed oil, prepared by a special process, mixed with ground cork and placed upon a strong backing of water-proof canvas.

Counter-boring. An enlargement or other alteration of form, for a certain portion of its length, of a hole bored in any substance.

Counterbrace. **55**, figs. 435-73, and **165**, fig. 456. *In bridge-building*, a brace which carries a load in the opposite direction to a main brace, or resists the tendency to buckling of panel, when the shear due to dead load exceeds that of the live load. *In car-building*, a counterbalance usually means a brace in the side of the body between its ends and the body-bolster. Sometimes there are two styles of counterbraces: one, near the middle of the car, is alone a counterbrace proper, in the technical sense, and called *centre counterbrace*; while the other is designated as the *counterbrace* or *overhang brace*, and generally the only counterbrace recognized in car-building. See *Body counterbrace*.

Counterbrace rod. An inclined rod which acts as a counterbrace. See above and also *Body counterbrace-rod*.

Counterbrace-rod plate-washers. **34b**, **34c**, figs. 229-66, etc. Washers that rest upon the plate and receive the end of the counterbrace-rod.

Coupler. That which couples. In relation to cars the term usually designates the appliances for coupling or connecting cars together. The word is more appropriately applied to the automatic car-coupler, which performs the act of coupling itself. The term is sometimes used to designate the *coupling* of steam pipes between cars, but this is unfortunate, as it seems desirable to maintain the distinction already established. To apply the term *coupling* to an M. C. B. automatic coupler would be an innovation, and it would seem equally so to call a *steam-hose coupling* a *coupler*. See *Automatic freight-car couplers*.

Coupler-gages. Gages adopted by the M. C. B. Association in 1891 to preserve the contour line for couplers. These gages may be obtained from Pratt & Whitney Company, Hartford, Conn.

Couplers, automatic. For M. C. B. Rules for Interchange of traffic with regard to couplers, see *Drawbar and attachments* and *Interchange of traffic*.

Couplet (of springs). **80**, figs. 4748-49. Two elliptic springs, which see, placed side by side, to act as one spring. Three springs united in this way form a *triplet*, four a *quadruplet*, five a *quintuplet*, six a *sextuplet*.

Coupling. "That which couples or connects, as a hook, chain, or bar."—*Webster*. A coupling-link was called simply a coupling. See *Coupler*.

See *Basin-coupling*.

Bell-cord coupling.

Berth curtain-rod

coupling.

Brake-hose clutch-

coupling.

Brake-hose coupling.

Clutch-coupling.

Coupling-link.

Head-board coupling.

Hose-coupling.

Pipe-coupling.

Reducing pipe-coupling.

Screw-coupling (Eng-

lish).

Steam hose-coupling.

Coupling-bar. See *Brake-lever coupling-bar*.

Coupling-bar pin (brake gear). A pin for the *brake-lever coupling-bar*, which see.

Coupling-case. See *Brake-hose-coupling case*.

Coupling-chain, or chain coupling-link. A three-link chain used in coupling to *draw-hooks*, which see. See also *Safety-coupling-chain*, figs. 5538-9, 5552-5; **55**, figs. 2441-5.

Coupling-hook. Fig. 1746a. A bracket with a hook projecting on which the hose coupling is hung when uncoupled.

Coupling-hook. Figs. 5538-9, 5552-5. A hook for coupling cars together. See *Drawbar coupling-hook* (of Miller coupler).

Coupling-hose (Eames' vacuum brake). 1. Figs. 1668, 1677-9. A flexible rubber hose lined with wire coil. Usual sizes, 1, 1½, and 1¾ in. diameter and 22 to 24 in. long.

2. (Westinghouse brake.) Figs. 293, etc. More commonly *brake-hose*.

Coupling-link. **2**, figs. 2073-4. A wrought-iron link or

open bar by which freight-cars are coupled together by *coupling-pins*. *Chain* coupling-links are used with draw-hooks. In consequence of the danger to trainmen attending the use of coupling-links, and legislation forbidding their use after January 1, 1898, *automatic car-couplers* are rapidly replacing them. See *Car-coupler*.

2. (English.) 42, figs. 348-51. A link forming part of a *wagon-coupling* or *draw-chain*. The open-ended link connected to the draw-hook or draw-bar is the *coupling-shackle*. The intermediate links are sometimes termed the *short links*, and the end link the *long link*. A single long-link is often used instead of three short intermediate links.

Coupling-pin. 1. Figs. 2073-4. A short bar of iron with which a coupling-link is connected to a brawbar.

2. (Automatic couplers.) One carried for emergencies or occasional use, to couple with a link.

Coupling-pin chafing-plate (Miller coupler). An iron plate attached to the outside of a platform end-timber to protect it from being worn by the *coupling-pin chain*.

Coupling-pin chain. A small chain attached to the car by a suitable *eye* to prevent the coupling-pin from being lost.

Coupling-pin plate (Miller coupler). An iron plate on top of the platform end-timber near the outside end, and which forms a guard for a hole in the timber to hold the coupling-pin.

Coupling-screw (English). 43, figs. 501-4. A right- and left-handed screw used in a *Screw-coupling*, which see.

Coupling-shackle (English). 41, figs. 348-50, and 501-4. The end link of the coupling which is secured by a pin to the shank of the *draw-hook*, which see.

Coupling-spring (Miller coupler). 49, figs. 2290-2. A spring made of two or more flat and nearly straight plates which bear against the back of the drawbar coupling-hook so as to cause it to engage with the hook of the adjoining car; also called the *leaf-spring*.

Coupling-spring bracket (Miller coupler). A cast-iron lug attached to one of the drawbar timbers, to which a bolt is fastened for increasing the tension on the coupling-spring.

Cover.

See *Drum-cover*.
Journal-box cover.
Man-hole cover.
Molding-joint cover.

Urinal-cover.
Window-molding-joint cover.

Covered wagon (English). A roofed vehicle used for conveying freight liable to be stolen or to be damaged by damp. It has side doors which can be locked, and occasionally doors in the roof so that the contents can be readily hoisted. As a rule, *tarpsaulins*, which see, and open cars are used in English.

Cover-plate. A *face-plate* of a steel-tired wheel is a disk connecting the tire and hub. A ring covering the packing inside the tire of an Atwood hemp-packed wheel.

Cover-strip. 1. (Refrigerator car.) Metal plates covering a gutter in the floor.

2. A strip of metal, or sometimes wood, to cover a joint in the roof-sheets.

Crabs, or tongs (pile-driver car). 22, figs. 401-4. (Wrecking car). See *Tongs*, also called *rail-clips* or *rail-clamps*.

Crane (pile-driver car). 34, figs. 401-4. See *Pile-driver car* and *Derrick*.

Crane-post. 4, figs. 389-96. The post of a crane, and corresponds to the mast of a derrick.

Crank. 1. "Literally a bend or turn; hence an iron axis with a part bent like an elbow, for producing a horizontal or perpendicular motion by means of a rotary motion or the contrary."—*Webster*. See *Bell-crank*. See also *Brake-shaft crank*. *Door-shaft crank* (street-cars).

2. (Of a derrick or crane.) 22, figs. 392-3. The L-shaped handle by which the driving-gear is actuated.

3. (Of a lever hand-car.) 6, figs. 5592-5600. The *bell-*

crank (which see) of a hand-car; 23, is at the upper end of the connecting-rod, the *crank* at the lower end.

Crank hand-car. Fig. 5616. A hand-car which is worked by one or two cranks connected by gearing with the axles of the car. Originally in very general use, it is now nearly obsolete in favor of *lever hand-cars*, which see.

Crank-shaft (lever hand-cars). 6, figs. 5592-5600. A short wrought-iron shaft to which a crank of a hand-car is attached, which is turned by suitable levers and is connected by gear-wheels with one of the axles of the car.

Crank-shaft bearings (hand-car). 5, figs. 5592-5600.

Creamer automatic ventilator. Figs. 4314, 4318. See *Ventilator*.

Crib-rail (English). 64, figs. 348-51. A longitudinal piece of timber secured to the upper part of the outer side of the *sole-bar* and supporting the body of the vehicle.

Cricket-iron. A *Seat-stand*, which see.

Cripple-post. 195, fig. 5666. (Street-cars.) A post of an end window, where the window is not of the full width, between the *door-post* and *corner-post*.

Crooked end-piece (wooden truck-frames). 17, figs. 4944, and 5109-10, 4833. An outside end-piece hollowed out on top by cutting away the wood so as to clear the draw-timbers and drawbar fixtures.

Cross-bar (swing link-hanger). Fig. 4914. The bar supporting the *cross-bar casting* which carries the *spring-plank*. Also called *mandrel-pin* and *lower swing-hanger pivot*.

Cross-bar casting, or spring-plank carrier (swing link-hanger). See *Cross-bar*.

Cross-beam (on sills). D, figs. 325-7. A transverse floor-timber placed upon the sills to support the inclined floor of a coal or ore car.

Cross-bearer (English). 3, figs. 348-51, 501-4. American equivalent, *cross-frame tie-timber*, *needle-beam*, and sometimes *cross-bearer*. A transverse member of the *under-frame*, placed between the ends of the vehicle. It serves to transfer the weight of the body and lading to the *sole-bars*, and keep the latter apart. Also called *cross-bar* or *transom*.

Cross-frame king-post, or truss-block. See *Cross-frame truss*.

Cross-frame tie-bolt. A *sill tie-rod*, which see. 10, figs. 229-66.

Cross-frame tie-timber. 22, figs. 229-66, 132-8; 26, figs. 435-73. A transverse timber bolted to the under-side of the longitudinal sills and floor timbers of a car-body between the bolsters, and to which the body king or queen posts, or truss-blocks, are attached when truss-rods are used under a car-body.

The term *needle-beam*, which see, taken from bridge engineering is also used, but *cross-frame tie timber* is in greatest favor. Other names are *body-transom*, *cross-bearer*, *cross-berth*, etc.

Cross-frame truss. 26t, fig. 536. A truss for a needle-beam or cross-frame tie-timber. The various parts, *king-post*, *truss-rod*, *truss-rod washer*, etc., are shown.

Cross-frame truss-rod. See above.

Cross-head. 1. (Westinghouse driving-wheel brake.) 6, fig. 1747. A wrought-iron T-shaped head attached to the lower end of the piston-rod, and to which two *eccentric-lever links* are attached, to connect the piston-rod with the eccentric-levers which work the brake-blocks.

2. (Westinghouse brake.) A forked casting attached to the outside end of a piston-rod, to which the brake-levers are connected.

Cross-sill castings. Figs. 1029-30.

Cross tie-timber. 22, figs. 229-66, etc. A *cross-frame tie-timber* or *needle-beam*, which see.

Cross-tie-rod (street-car). Figs. 5655, etc. A *sill tie-rod*.

Cross-tie-timber truss-rod seat. Figs. 1347-8. A body-truss-rod bearing.

Cross-tie-timber-truss-rod. See *Cross-frame truss*.

Cross-tie-timber truss-rod bearing. See *Cross-frame king-post*, etc.

Cross-timber hopper-ends. C, figs. 325-7. A transverse floor-timber framed between the intermediate sills, to which the lower end of the inclined floor is spiked and to which the outer hopper-doors are hung. The ends of the *draft-timbers* are bolted to it and the *short-center-sills* abut against it.

Crown lamp-shade. Fig. 3428. See *Lamp-shade*.

Crown-molding (street-cars). Figs. 5654-6. A molding on the inside above the deck sash and tacked to the *deck-posts* and *carlines*.

Crown-piece (street-cars). 67, figs. 5654-67. A *platform end-timber* or *sill*.

Crown-piece corner-iron (street-cars). 68, figs. 5656, etc. A strap-iron that protects the corner of the *crown-piece*.

Cuff-rack. Figs. 3519, 3515. For lavatories.

Cup. 1. "A small vessel used commonly to drink out of, but the name is also given to vessels of like shape used for other purposes."—*Webster*.
See *Buffer-spring cup.* *Oil-cup.*
Candle-holder cup. *Side-bearing cup.*
Drain-cup.

Cupboard-bolt. Figs. 2550-3. See *Door-bolts*.

Cupboard-catch, or flush-bolt. Fig. 2548. A very indefinite term for a light spring catch nearly or quite flush with the surface to which it is attached. It has a beveled bolt which snaps shut.

Cupboard-latch. Fig. 2548. See above.

Cup-holder, or tumbler-holder. Figs. 3495-3501. A stand or rack for holding a drinking-cup. See *Alcove cup-holder*.

Cup-leather (for piston-rod of Westinghouse driving-wheel brake-cylinder). A substitute for ordinary gland-packing.

Cup side-bearing. A side-bearing for trucks, with a receptacle for holding oil and waste. Little used.

Cup-washer. A *socket-washer*, which see.

Curled-hair. Hair from the tails or manes of cattle, horses, etc., which is first spun into ropes, then wound into coils, and either steeped or boiled in water. After this the coil is dried and the hair unwound, which leaves it in a curly and elastic state, suited for stuffing cushions, etc.

Curtain. 17, fig. 2409. A cloth hanging in front of or around any space or object, as a window or sleeping-car berth, and which may be contracted or spread at will. The term, however, is usually restricted to loosely-hung drapery, suspended on a *curtain-rod* by *curtain hooks* or *rings*, in distinction from a *shade*, which is flat and rolls up. Curtains in cars are chiefly used for sleeping-car berths (*berth-curtains*, which see) and for the sides of *summer street-cars*, which see. *Window-curtains* are used in dining, parlor, and private cars. Except in the saloon, blinds have been abandoned and *window-shades* are in almost universal use on steam railroads. Blinds are still in general use in street-cars.

Curtain brackets (Hartshorn and McKay, which see). Figs. 3567-4575. One bracket has a circular hole and the other a rectangular.

Curtain fixtures. Figs. 3559-66, 3578-3623.

Curtain-holder. See *Magnetic curtain-holder*.

Curtain-hooks (sleeping-berths). Figs. 4223-6.

Curtain-rings. Figs. 3579-82. Rarely used. See *Curtain*.

Curtain-rod. Fig. 3578 (English); 190, fig. 501. A bar to carry a curtain hung upon rings and sliding freely along the rod.

Curtain-rod bracket. Figs. 3564-66, 3607-15.

Curtain-rod bushing. Figs. 3618-23. A socket or bushing for the end of a curtain-rod as it abuts against a wall or partition.

Curtain-rod folding-bracket (sleeping-car). Figs. 4194, etc.; 15, figs. 2409-12. A bracket for a curtain-rod in a sleeping-car, which may be folded into the upper berth,

in such a manner that it is out of sight when the upper berth is shut up. See *Folding-curtain rod-bracket*.

Curtis Electric Company's street-car motor. Fig. 5678.

Curved seat-slat. Figs. 4006-7.

Curved seat-stop. Figs. 4053-7. See *Seat-stop*.

Cushion. 1. Figs. 3927-51, 3957-67. Cushions used in passenger-car upholstery are of the box type, being built upon and connected with a wooden framework (*cushion-frame*). See *Seat-cushion*.
2. See *Rubber-cushion*. A platform buffer-spring.

Cushion back-rail (English). 151, figs. 501-2. In a carriage a small transverse bar which confines the hind end of the seat-cushion.

Cushion-frame. Figs. 3917, 3929-38, 3960-7. A wooden frame to which the seat-springs and upholstery of a car-seat are attached.

Cushion weather-strip. Figs. 4538-41. See *Weather-strip*.

Cuspidor. Fig. 2859. A vessel to receive discharges of spittle, and having a wide rim so that if it is upset its contents will not be spilled. It is the modern substitute for a *spittoon*, fig. 2858, from which it differs only in form.

Cut-out-cock. Fig. 1744. See *Brake cut-out-cock*.

Cylinder. 1. A chamber or vessel whose ends are circular, and with straight parallel sides, as the cylinder of a steam-engine. The cylinders used in connection with cars and locomotives are made of cast iron, and have pistons fitted so as to work air-tight in them. Cylinders used in brake apparatus are shown in figs. 1726-31, 1748. Also see *Air-cylinder*. *Brake-cylinder*.
2. A name sometimes given to the fire-pot of a stove or heater, as in fig. 2888.

Cylinder-body (Westinghouse brake). The main central portion closed by the *cylinder-heads*.

Cylinder-head. A metal cover for the end of a cylinder, held on by *cylinder-bolts* or *cylinder-studs*. The cylinder-head through which the piston passes is commonly termed the *back* cylinder-head, and the other the *front* cylinder-head, corresponding to locomotive practice. In the Westinghouse air-pump and engine they are designated as *top* and *bottom* cylinder-heads. See *Cylinder*.

Cylinder-levers (Westinghouse brake). 7, figs. 1693-4. Two levers which are connected together by a *tie-rod* attached near their centers. One end of one lever is attached to the cross-head of the brake-cylinder, and the corresponding end of the other is attached to a bracket on the brake-cylinder head at the opposite end of the cylinder. The other ends of the levers are connected with the floating levers by rods.

Cylinder-lever and Hodge-lever connecting rod. 8, figs. 1693-8.

Cylinder-lever bracket (Westinghouse brake). Fig. 1693. A T-shaped piece of iron bolted to the front cylinder-head, to which one of the brake-levers is attached.

Cylinder-lever-guide. 15w, figs. 1693-8.

Cylinder-lever support (Westinghouse brake). Figs. 1693-8. A wrought-iron bar bolted to one of the center sills, on which the ends of the cylinder-levers rest.

Cylinder-lever tie-rod (Westinghouse brake). 14, fig. 1694. See *Cylinder-lever*.

Cylindrical gages. Gages made for measuring the size of cylinders and cylindrical holes, often called Whitworth gages. They consist of steel cylinders and rings hardened and ground very accurately to standard sizes. These fit into each other. The first is used for measuring the size of holes and the last for measuring the outside of cylindrical objects, and they are called *internal* and *external cylindrical-gages*. They are generally used as standards alone, from which other tools and gages are made of the proper size.

Cylindrical stove. See *Stove*.

"Cyrus Roberts" steel-tired wheel (hand-car). Figs. 5626-8. An all steel wheel, except the hub. The spokes are threaded at the hub and felloe. New steel-tires may be shrunk on the wheel center.

"Cyrus Roberts" truss-frame combination hand-cars. Figs. 5583-4. A hand-car having several new features, viz.: 1. Truss-rods secured to the four corners of the car-frame, forming two diagonal trusses, each provided with "turnbuckle" adjustment, to keep axles in line, impart rigidity to the frame, and to overcome the tendency to "twist" or "wring."

2. A compound brake applied simultaneously to both wheels, with the foot lever hung back of center of car.

3. Steel pedestals supporting the frame of car, providing a secure and firm seat for the boxes.

4. Propelling levers that may be detached at a moment's notice and the car converted into a *push-car*.

D

Damper. See *Stove-pipe damper*. A valve for regulating the draft.

Damper-handle. See *Stove-pipe damper-handle*.

Danger-signal. Usually a signal made by a person with a flag or lantern to warn a train that there is danger ahead. For such warning, flags, lights, and torpedoes and fuses are used, red flags and lanterns being usually a sign of danger. On a train a danger-signal is a red light or flag attached to the rear of the train; green is used to signify caution; white for safety.

Dasher or dashboard. See below.

Dash-guard (street-cars). 79, figs. 5664-67. A plate attached to the platform-railing to prevent mud or snow from being thrown upon the platform. Called a *dash-board* and a *dasher*.

Dash-guard straps. 81, figs. 5654-67. Small clips by which a dash-guard is fastened to the platform posts. Also called *dasher-post clip*.

Dasher-post (street-cars). 80, figs. 5654-67. A post supported by the crown-piece which carries the *dasher* and the *platform rail*. Called on steam-cars a *platform railing-post*.

Dasher-post washer (street-cars). 82, figs. 5654-67.

Dasher-rail (street-cars). 82, figs. 5654-67. A *Platform rail*.

Dasher-rail caps (street-cars). 85, figs. 5654-67. A wood or metal cap bolted to the dasher-rail for decoration and to prevent injuries.

Davis automatic car-shades. Figs. 4544-7. A car-shade, the automatic feature of which is the *holding-device* inserted in the bottom of the shade by which the shade may be left at any height desired. It consists of two rods in a metallic case connected in the middle with an eccentric, turned by a *thumb-latch*. At the outer ends of the case rubber wheels are placed which bear against the window casing, and these rods carry a braking device which restrains these rubber wheels from turning, thus holding the shade.

Davis journal-box lid. A pressed steel journal-box lid of the Fletcher type, but with the spring on the inside.

Davis shade-holding device. See *Davis automatic car-shades*.

Day coach. Figs. 89-96. A common term for an ordinary passenger-car in distinction from sleeping-cars. It ought in strictness to include parlor-cars, but in general does not. It is often termed a *coach* simply, which see.

Dayton freight-car door-lock. Figs. 2736-7. See *Door-hasp*.

Dead air-space (insulation of refrigerator-car). Air-spaces which have no communication with the atmospheric air outside, so there can be no free circulation or change of air as there is in a *free air-space*.

Dead-block. 1. Fig. 5549. A single wooden block or stick of timber attached to the end-sill of freight-cars to protect persons between the cars from injury, by preventing the cars from coming together in case the drawbar or its attachments should give way. They are called dead-blocks from the fact that they are blocks which subserve no function in the construction of the car proper. See *Buffer-block*.

The M. C. B. standard dimensions recommended in 1882 were amended in Saratoga, 1884, as follows:

Buffer-blocks are to be made 8 in. square on the face and 6 in. thick, and are to be placed 22 in. apart from centre to centre, and to have 14 in. space between them.

Single dead-blocks are to be not less than 30 in. long, 7 in. thick, and 8 in. deep measured vertically.

2. (English.) A piece of hard-wood packing, interposed between the *buffer-rod guide* and the *head-stock*. This term is also improperly used to describe the *Buffer-rod guide*, which see.

Dead-center. "One of the two points in the orbit of a crank in which it is in line with the connecting-rod."—*Knight*. To avoid the annoyance of a dead-center two cranks are frequently applied to a shaft at 90 degrees with one another.

Deadening, or Deafening. The filling placed between the floor and the *deafening-ceiling* to serve as a non-conductor to heat and noise. *Mineral wool*, which see, is sometimes used for deadening, but commonly shavings, when anything at all is used. An *intermediate floor* (between the sills) and *deafening-ceiling* (under the sills) are used in refrigerator cars, as in figs. 277, 281.

Dead-lever (of brake-gear). 7, figs. 1535-7. 92A, figs. 4581, etc. The one of a pair of levers to which the brake-shaft connecting-rod is *not* attached. The upper end of the dead-lever is confined within a *dead-lever guide*, or *brake-lever stop*, which latter is provided with pins to adjust the end of the brake-lever as the brake-shoes wear. The lever to which the power is first applied is termed the *live lever*.

Dead-lever guide, or brake-lever stop (brake-gear). 95, figs. 4580-4756. See above.

Dead-lock. Figs. 2734-5. A lock in which the bolt is thrown each way by the key, and not in one direction by a spring, as with a spring-lock or night-latch.

Dead-padlock. A padlock in which neither the lock, bolt, nor hasp has a spring, but the former is thrown each way by the key, and the hasp must be opened by the hand.

Dead-wood. A *dead-block*, which see.

Deafening-ceiling. 28, figs. 435-73. Boarding on the under side of the floor-timbers of a passenger-car to exclude or deaden the noise of the car. When cut and inserted between the sills it is called a *deafening-floor*, but quite as often, though improperly, a *deafening-ceiling*. See *Deadening*.

Deafening-floor. See *Deafening-ceiling*.

Decatur grain-door. Figs. 1896-1926. A door suspended from the carlines over head when not in use. The *door-posts* are gained out and fitted with *angle-irons*, behind or between which the door fits. A lever is provided by which the door may be started from the bottom and the grain allowed to discharge itself automatically.

Deck. 102, figs. 435-73, 539-41. A term applied to the roof of a passenger-car by analogy from the deck of a ship. The term is not applied in general use, however, to freight-cars. The *deck* of passenger-cars is subdivided into the *upper-deck* (also called *clear-story*, which see) and *lower-deck*, the roof at the side of the clear-story; but in designating parts which belong to the clear-story alone and which are not repeated in the lower deck the term *deck* alone is used.

Since the issuing of the first edition of this work the use of the term *deck* instead of *clear-story* in compound words seems to have become practically universal among manufacturers of furnishings and in far more general use than any other among car builders. The manufacturers and railroad officers consulted almost unanimously replied that they used no other term than *deck*.

Deck-beam. 1. A beam in the form of an inverted T with a round knob on the upper end, used in some forms of iron car construction. The Marden steel brake-beam, fig. 1600, is a deck-beam.

2. **Y**, figs. 325-7. Transverse beams extend across a car from side-rail to side-rail to which the deck-planks are spiked.

- Deck bottom-rail.** 112, figs. 539-67. A horizontal timber running lengthwise of a car, fastened to the rafters and carlines of the main roof, or to the deck-sill, which forms the base for the dock-posts. The term is sometimes applied to the *deck-sill*.
- Deck-bridging.** See *Bridging*.
- Deck-carline, or upper-deck carline.** 118, figs. 435-73, and 536-67. A timber which extends from side to side of the upper deck, and supports the roof-boards. Corresponding parts in the lower deck are generally called *rafters*.
- Deck-collar** (Spear and other heaters). A sheet-metal ring to line the smoke-pipe opening through the roof, having a double sheet-metal tube to leave an air-space as a heat-guard, and a flange on the outside to exclude rain.
- Deck-cornice filling-block.** 121, figs. 551, 556, 560.
- Deck eaves-molding, or upper-deck eaves-molding.** 119, figs. 435-73, 542-67. A molding under the outside edge of the upper deck.
- Deck end-panel.** 116, figs. 435-73, 539-67. It is frequently used as a ventilator.
- Deck end-plate.** K, figs. 514-15. A member that fulfills the same office for a clear-story that the *body-end-plate* does for the body. See *End-plate*.
- Deck end-sill.** 113, figs. 435-73, 539-67. A horizontal timber connecting the ends of the deck-sills, and forming the base for the end of the upper deck.
- Deck end-ventilator.** See *Deck end-panel*.
- Deck end-ventilator hood** (street-cars). 165, figs. 5654-8. A projecting screen, placed over the aperture of an end-ventilator, to exclude snow and rain. Also called *upper-deck hood*.
- Deck inside cornice.** 120, figs. 539-67. A molding which fills the interior angle where the upper deck joins the deck-side.
- Deck-planking.** V, figs. 325-7. Planking nailed to the side and end rails of a coal or ore car to form a deck.
- Deck-plate.** 117, figs. 536-67. A horizontal timber on top of the deck-posts or mullions to which the deck carlines are attached. Also called a *deck-top-rail*.
- Deck-post.** 115, figs. 536-67. An upright piece of wood which connects the deck-plate with the bottom rail.
- Deck-sash.** 144, figs. 539-67. A glazed sash in the sides of the upper deck.
- Deck-sash-catch.** Figs. 4375. A hook giving a simpler equivalent for a *deck-sash latch*.
- Deck-sash double-ratchet.** Fig. 4400. A special form of deck-sash pivot-plate, used with spring ratchets.
- Deck-sash flush-catch.** A *Deck-sash latch* mortised into the sash rail flush with the sash.
- Deck-sash latch.** Figs. 4369-74. A spring-bolt attached to a deck-sash, which engages with a deck-sash latch keeper or *strike-plate*. See *Keeper*.
- Deck-sash latch-keeper.** Figs. 4381-4. See above.
- Deck-sash lintel.** See *Lintel*.
- Deck-sash opener.** Figs. 4330-41. A lever attached to a revolving rod by which a deck-sash is held in any desired position. A great variety of forms exists, including many patented devices. See engravings. A *pull-hook*, figs. 4376-80, is sometimes called a deck-sash opener, but a more elaborate contrivance is generally meant.
- Deck-sash, outer.** 144a, figs. 550-67. A deck-sash which carries the screen, and prevents the admission of dust and cinders.
- Deck-sash pivot.** Figs. 4351-64. A metal stud or spindle attached to a suitable flange by which it is fastened to a deck-sash, and on which the latter turns. A variety of forms exists, including several patented devices, as Monitor, fig. 4397-8; Morgan, figs. 4385-8, etc., to render the sash readily removable and adjustable.
- Deck-sash pivot-bushing.** Same as figs. 4407-8. See *Bushing*.
- Deck-sash pivot-plate.** Figs. 4355-6. A plate attached to the window-casing, with a hole or eye in which a deck-sash pivot works. Sometimes they are provided with springs to prevent the sash from rattling.
- Deck-sash pull.** Figs. 4342-50. A screw-ring attached to a deck-sash to open and close it. Made either *with screw* or *with flange*.
- Deck-sash quadrant.** Figs. 4390, 4396. A curved bar or plate of metal used as a guide or stop to control the movement of a deck-sash. Little used.
- Deck-sash quadrant clip.** Fig. 4390. A guide-strap embracing a deck-sash quadrant.
- Deck-sash ratchet-plate.** Figs. 4397, 4399, and see 4391-3. A part usually attached to the side of the car, but sometimes to the sash, carrying a *ratchet* in which the ratchet-catch engages.
- Deck-sash socket.** Fig. 4394. A hook attached to a peculiar form of deck-sash pivot. See engravings.
- Deck-sash spring pivot.** Figs. 4353-5, 4363. A deck-sash pivot, which see, provided with a spring to make the sash removable.
- Deck-screen.** 144b, figs. 542-67.
- Deck-screen bottom-rail.** 112A, figs. 470. A rail running the entire length of the *clear-story*, and closing the space between the bottom of the screen and the roof.
2. (Of ventilators, which see.) Figs. 4300-24.
- Deck-screen sash-sill.** 180, fig. 560.
- Deck-side.** The entire part, consisting of a plate, rail, posts, and panels, or sashes, which forms the side which occupies the vertical space between the lower and upper deck.
- Deck side-ventilator.** Figs. 4319-22. This term is also used to designate the sash or valves and their attachments for opening and closing the aperture.
- Deck-sill.** 111, figs. 531-67. A horizontal timber attached to the inner ends of the rafters, or short carlines, on which the deck-side rests.
- Deck-sill bottom-molding.** 114a, figs. 542, 560.
- Deck-sill facing.** 114, figs. 531-67. Thin boards or moldings attached to the inside of a deck-sill, for ornament.
- Deck-sill side-molding.** 111a, figs. 554, 560.
- Deck-sill top-molding.** 111B, figs. 554, 560.
- Deck soffit-board.** 121s, figs. 539-67. A board on the under side of the overhanging cornice of an upper deck.
- Deck top-rail.** 117, figs. 539-67. A *deck-plate*, which see.
- Deck-ventilator.** See *Deck end-ventilator*. *Deck side-ventilator*. The deck-sashes are frequently hung and operated as deck side-ventilators as by the *continuous deck-sash opener*. Fig. 4349.
- Deck window-screen.** S, figs. 539-41. An outside sash with a screen over it to exclude dust and cinders.
- Deck-timber** (snow-plow framing). 23, figs. 410-1.3 A rail, capping the *throat-pieces* and *side-posts* of a snow-plow frame.
- Decorated-ceilings.** 9, figs. 2452-3a, and in general interior views, figs. 90-133.
- Defiance improved asphalt car-roofing.** A composition car-roofing material made by saturating and coating a heavy web of burlap with refined Trinidad asphalt tempered with a mixture said to contain no coal-tar or petroleum residuum. On the face of the saturated and coated web is run another web of heavy burlap, and on the back is run a tough sheet of rope fiber paper. While the material is still fresh it is run through pressure rolls which imbed and set the surface web of burlap into the asphalt, making a compact sheet of heavy roofing material which is strong, flexible, elastic, and water-proof. The material is used between boards, of double roofs, similar to the *Carey* and *Hutchins* roofs. It is made by the A. E. Filley Mfg. Co.
- Deflector.** 1. (For windows.) Figs. 4527-30. A piece of thin board attached to the jamb of the window and left projecting two or three inches beyond and at right angles to the car. When the car is in motion it deflects the cinders and dust from the window, and also produces an exhaust draft. Also called a *window dust-guard*.

Deflector-springs (of ventilators). Springs controlling the movement of the deflectors.

Deflector ventilator. A name given to the Pancoast ventilators, fig. 4317.

Derrick. Figs. 77-80, 206, 392-3. "A form of hoisting machine. The peculiar feature of a derrick, which distinguishes it from other forms of hoisting machines, is that it has a boom stayed with a central post" (termed the *mast*), "which may be anchored, but is usually stayed by *guys*."

"A *derrick* has one leg, a *shears* two, and a *gin* three. A *crane* has a post and a *jib*," and is a *rigid* machine, not having a movable boom. "A *whin* or *whim* has a vertical axis on which a rope winds. The *capstan* has a vertical drum for a rope, and is rotated by *bars*. The *windlass* has a horizontal barrel, and is rotated by *hand-spikes*. The *winch* has a horizontal barrel, and is frequently the means of winding up the tackle-rope of a derrick; it is rotated by *cranks*. The *crab* is a portable winch and has cranks.

"The derrick is more commonly used in the United States than in Europe, and has attained what appears to be maximum effectiveness with a given weight. Two spars, three guys, and two sets of tackle—one for the jib and one for the load—complete the apparatus, except the winch, crab, or capstan, for hoisting.

"The invention is nautical, the original being the sailor's contrivance, made of a spare topmast or a boom, and the appropriate tackle. Such are used in masting, putting in boilers and engines, and hoisting heavy merchandise on board or ashore.

"The *derrick-crane* is a combination of the two devices, as its name imports, having facility for hoisting and also for swinging the load horizontally."—*Knight*.

Derrick-car. Figs. 77-80, 206-7, 392-6. A strong platform-car which carries a *derrick-crane* which is used for removing wrecked cars and engines, erecting bridges, or handling any heavy objects. Also called *wrecking-car*. They are distinguished as *hand* or *steam* derrick-cars, according to the power used.

Derrick truss-rod. Figs. 392-3. A rod attached to the side-sills of a derrick-car at each end and passing under the *mast-pocket* or other equivalent compression-block, constituting a truss to resist the pressure of the derrick.

Destination-board bracket (English). 183, fig. 501. A small shelf of cast or wrought-iron secured to the upper part of the outside of the body, in order to carry a wooden board or enameled metal plate, giving the destination of a train. It is universally used on all English carriages, and carried throughout the entire trip.

Destination-card and rack (freight-cars). 80, fig. 254. A convenience in increasing use, but usually conspicuous by its absence.

Detachable globe-holder. A globe-holder arranged so that a lamp-globe can readily be attached or removed. Many lamps have the globes fixed or *plastered*. Hence, often called *plaster-lamps*.

Detaching-slot (of deck-sash ratchet). B, fig. 4397. A slot in the ratchet-plate to facilitate removal of the sash.

Details of cars:

Box-car. Figs. 617-902.

Baggage car. Figs. 1476-1427.

Body-bolsters. Figs. 1428-57.

Brake-gear. Figs. 1458-1782.

Caboose-car. Figs. 1132-75.

Doors. Figs. 1783-1935.

Draft-gear. Figs. 1936-2354.

Flat-car. Figs. 916-1024.

Gondola car. Figs. 1025-1131.

Roofs. Figs. 2355-97.

Signal-apparatus. Figs. 2388-2407.

Sleeping-berths. Figs. 2408-18.

Vestibules. Fig. 2419-50.

Windows. Figs. 2451-53a.

Detective wire (for seals). Figs. 3886-7. A flat twisted wire or other equivalent device to prevent the seal being stripped from the wire without destroying one or both.

Detroit brake-beam. Figs. 1594-8. A built steel beam of unique design. Instead of a truss-rod and king-post, the tubular beam with a slit throughout its length, and its edges flanged, is stiffened by a web, through which the brake-lever passes.

Diagonal (English). 4, figs. 349 and 502. American equivalent (used chiefly in street-cars), *diagonal floor-timber*. A member of the under-frame. One end butts against the rear side of the transverse end member of the under-frame (the *head-stock*), and the other end butts against an intermediate transverse member of the under-frame (the *cross-bearer*) near its center. The *diagonal*, take the strain of the side-buffers, and distribute it so as to prevent distortion of the *under-frame*.

Diagonal floor-timbers. Floor-timbers which are placed in an inclined position to the sills. Used chiefly on street-cars.

Diagonal roof-strap (street-cars). A band of hoop-iron placed diagonally on the top of the roof-boards to stiffen the roof.

Dial-cock (Consolidated car-heating). Fig. 2979. A $\frac{3}{4}$ -inch asbestos packed cock, the flange of which is made in the form of a dial to indicate the amount of opening of the cock. It indicates to the eye the exact position of the plug and the size of the opening for the admission of steam.

Diameter testing-gage (for car-wheels). A gage for testing wheels and axles. Sometime, an M. C. B. standard.

Diamond-truck. Figs. 4580-4748. A car-truck with iron side-frames consisting of two or more *arch-bars*, which see, and a *pedestal tie-bar*. The spaces between the arch-bars are diamond-shaped, whence the name. The journal-boxes are rigidly bolted to the sides. The cross-members of the truck, bolster, spring-plank, etc., are either of wood or iron, or of both wood and iron combined. Iron transoms, bolsters and spring planks may be said to be in general use and increasing in favor. See figs. 4576-4805.

At the Master Car Builders' Convention (1884) it was voted that this form should be the type used in preparing designs for a standard freight-car truck, to have a 5 ft. wheel-base, channel-bar transoms, and either *swing* or *rigid bolster*, which see. It is the type in almost universal use for freight-cars, and the *rigid-bolster* is applied to nearly all new construction. The *swing-bolster* truck remains a standard on a few important roads that have a large traffic of live-stock.

Diaphragm. 1. (Eames vacuum brake.) 1, figs. 1669-72. An equivalent for the Westinghouse *brake-cylinder*, serving to operate the brakes. It consists of a cast-iron bowl-shaped *shell*, to which the *diaphragm-rubber* is attached by *diaphragm-rings*. A rubber *diaphragm-hose* connects it to the brake-pipe. Three sizes of diaphragms are manufactured: No. 4, for narrow-gage cars, No. 3 for standard-gage cars, and No. 2 $\frac{1}{2}$ for heavy driver-brakes.

2. (Pintsch gas pressure-regulator.) Fig. 3168.

3. (Refrigerator-car.) See *Condensing diaphragm*.

4. (Westinghouse brake and train-signal apparatus.)

Some valves are regulated by *diaphragms* or *diaphragm-plates*, to which are attached springs, nuts, stems, etc., etc., whose names explain themselves. See figs. 2403-4. These diaphragms all operate on the same principle. They are spring-plates which guide the rod and, assisted by spiral springs, cause the attached valves to seat or unseat at a fixed pressure.

5. (Of a vestibule.) 2, figs. 2419-48; fig. 2422a. A piece of rubber, ducking, or canvas in folds attached to the *diaphragm face-plate* and platform-inclosure to exclude the dust and cinders, and at the same time to allow the face-plates free movement, laterally and longitudinally, in the Barr and Gould vestibules, and longitudinally only in the Pullman vestibules. The *Barr wing-vestibule* has no diaphragm.

Diaphragm face-plate. 1, figs. 2419-48. See *Face-plate*, *Diaphragm*, *Vestibules*, *Pullman*, *Barr*, and *Wagner Vestibules*.

Dictionary of Terms (Master Car Builders). At the fifth Annual Convention, held in Richmond, Va., in 1872 (see page 18 of the report of that meeting), it was

"Resolved, That a committee with power to publish an illustrated book, defining the proper terms or names of each and every part used in the construction of railway cars, and a description of the use of the same."

At the Fourteenth Annual Convention, held in Detroit, in 1880, "The committee to which was assigned the duty of preparing a dictionary of terms used in the construction of cars submitted a copy of the book and reported that it had finished its work, and it was discharged." See *Front part of book*.

Differential car-door hanger. Figs. 2831-4. See *Car-door hanger*.

Differential screw-jack. Figs. 3736-9. See *Screw-jack*.

Dining-car. Figs. 101-10, 179, 191, 474-86. A car provided with a kitchen and cooking appliances and arrangements for serving meals as in a hotel. *Hotel-cars* which are now quite out of use, had similar arrangements on a smaller scale, but they were mainly given up to sleeping-berths. The term *diner* is in bad taste, since the car has not the capacity to *dine*.

The first dining-cars were probably those run on the Philadelphia, Wilmington & Baltimore road in 1863-5, but these cars had no arrangements for cooking, but received cooked provisions at the end of each run. On the more modern cars nearly all their cooking is done on the car itself. Dining-cars are usually luxurious in their appointments and are run by the companies themselves and at a slight pecuniary loss, with the object of attracting travel. They are in general use. Dining-cars are to be distinguished from *lunch-cars*. A dining car is a place where a full-course dinner may be cooked and served with the service usually furnished in hotels, and the whole car is given to that end. They are frequently attached to a train for a few hours only at about meal-time. A *lunch-car* partakes more of the character of a lunch-counter, and the food served is not cooked on the car. It is a revival of the earliest dining-car above mentioned.

Dining-car range. Figs. 474 and 3106-8. See *Range*.

Directors'-car. Figs. 119-20. A car built and maintained expressly for the Directors and officers of the road. An *officers' car*.

Directors'-car range. Fig. 3108. See *Range*.

Direct steam-heating systems. Figs. 2959-60, 2999, 3032, 3036. A system of car heating in which the steam from the locomotive or heat-tender is carried directly to the radiators or heating-pipes. The term is used to distinguish the system from those in which the steam is employed to heat the water which circulates in the radiators or heating-pipes, usually in connection with the *Baker-heater*. See *Consolidated, Gold's and Safety's systems of car-heating*.

Direct steam-storage system. Figs. 3001, 3009-10. A direct system of car heating, in which the radiating-pipes are enlarged and inclose a smaller pipe or tube which is filled with salt water or other heat-retaining substance, and which when heated continues to radiate heat after the steam is shut off. In the Gold terra-cotta storage-heater the radiating pipe contains a fluted cylinder of terra-cotta of the same extreme diameter as the inside diameter of the radiating pipe. These storage-heaters are shown in detail in figs. 2961-7, 3009-10. See *Consolidated and Gold's car-heating systems*.

Direct steam-storage system (Consolidated car-heating). Fig. 2959. A system of heating in which a 2-inch pipe is divided into chambers and each chamber being half full of water, steam occupying the space above this water. As the pipe is but partly filled with water it is not liable to injure the heater by freezing. It heats quickly and makes a cheap and effective storage system.

Disc, wrought-iron, car-wheel center. Figs. 5296-5303.

Discharge-pipe (air-pump for Westinghouse brake, also called *reservoir-pipe*). 8, fig. 1699. A pipe by which the compressed air is conveyed from the air-pump to the main air-reservoir.

Discharge-valve. 1. (Of car-signal valve, Westinghouse train-signal apparatus.) 2402; 32, fig. 2388. The valve in the attachment called the *car signal-valve*. The whole device is also sometimes so called.

2. (Of air-pump for Westinghouse brake.) 30-33, fig. 1689. The valve through which the air as compressed passes to the main reservoir. There are two—*upper* and *lower*. See also *Auxiliary discharge-valve*.

Discharge valve-seat wrench (Westinghouse brake). See *Wrench*.

Discharge-valve stop (air-pump). 44, fig. 1689.

Disengaging-bolt (Howard's parlor-car water-closet). Figs. 3388-9. An attachment by which the water-supply valve and the pan are disconnected from the bowl proper, so that the closet can be used as a plain hopper in case the water supply gives out.

Dished-cap ventilator. Fig. 4306. See *Ventilators*.

Distance-block. A short, thick piece of wood placed between two or more objects to keep them apart, or to preserve an interval of space between them, as *floor-timber distance-block*, *truck-bolster distance-block*, etc.

Distance-gage (between backs of wheel-flanges). Fig. 5421. One of the M. C. B. standard wheel and axle gages.

Distance-piece. A metallic *distance-block*. See *Draw-bar distance-piece*.

Distributing-table (postal-car.) 4, figs. 599-604. A table upon which the mailbags are emptied of their contents, and from which they are distributed to the various boxes or pouches.

Distributing-table hinge. Fig. 2610.

Ditching-car. Fig. 217. A car provided with derricks and scoops for excavating the ditches of cuts by the power of a locomotive. The contrivance has been patented by the American Ditching Co., of La Crosse, Wis.

Dividing attachment (Eames, for engines fitted with drum-brakes). Figs. 1682-3. A device to regulate the application of the brakes to either the locomotive or train, or both.

Division-arm (twin-seats). Figs. 3924, 3955, 3974-6, 3981, etc. The middle seat-arm between the two seats.

Dog. 1. A general term in mechanics for all devices which bite or take hold of or give motion to other parts. See *Ratchet-dog*.

2. (For pawl of winding-shaft.) 69, figs. 305-15. A disk or button eccentrically pivoted in such a way as to hold the *ratchet-wheel pawl* of a winding-shaft in its place. The pawl itself of a ratchet-gear is also sometimes termed the dog in other forms of ratchet-gear where no dog to hold the pawl is necessary.

3. A *brake-pawl dog*, which see. A very similar part of that defined above.

Dome. A *clear-story* or *upper deck* is sometimes erroneously called a dome. See also *Tank-dome*.

Dome-head (tank-car). 109, fig. 373. The top of the dome.

"**Dome**" lamp-shade. Fig. 3426. A *lamp-shade*, which see, of curved or *ogee* outline.

Door. Figs. 1783-1935. A frame of boards for closing a doorway. See *Door-frame* for names of parts. See also

<i>Ash-pit door.</i>	<i>Lamp-case door.</i>
<i>Double-door.</i>	<i>Overhung-door.</i>
<i>Double fire-door.</i>	<i>Platform trap-door.</i>
<i>Draft-door.</i>	<i>Shaker-door.</i>
<i>Dust-door.</i>	<i>Sliding-door.</i>
<i>Dust hand-hole door.</i>	<i>Smoke-box door.</i>
<i>Fare wicket-door.</i>	<i>Sub-door.</i>
<i>Feed-door.</i>	<i>Tip-car door.</i>
<i>Fire-door.</i>	<i>Underhung-door.</i>
<i>Grain-door.</i>	<i>Ventilator-door.</i>
<i>Grated-door.</i>	

Door-apron (street-cars). A sheet-iron cover attached to a swinging door to inclose the step.

- Door-bolt.** Figs. 2535-53. A metal bar attached to a slide and fastened to a door so as to hold it shut from the inside. They are either *round*, or *barrel*, or *square*. A *square-neck* door-bolt is one with an angle or shoulder in it. *Flush* door-bolts are gained in so as to be flush with the surface, there are numerous styles shown in figs. 2544-53. A *cupboard-catch* is a form of door-bolt having a beveled latch and actuated by a spring, but bolts so formed are commonly termed *latches*, which see.
- Door-bolt keeper.** Figs. 2541-2. A catch attached to a door-frame, in which the bolt engages.
- Door bottom-rail.** 147, figs. 539-41; 5, fig. 1788. See *Door-frame*.
- Door-bottom ventilator-rail** (English). 112, figs. 501-4. A piece of wood running horizontally and supporting a sliding ventilator.
- Door-brace** (freight-car doors). A diagonal piece of timber framed to stiffen the door.
- Door-butt.** A *butt-hinge*, which see.
- Door-button.** "A small piece of wood or metal swiveled by a screw through the middle, and used as a fastening for a door or gate."—*Knight*. They are often attached by a rivet or pin to a metal *door button-plate*, which is fastened on with screws. Sometimes the button is an eccentric disk.
- Door-cap** (freight-car doors). 177, figs. 229-66. A horizontal board across the top of the door.
- Door-cap rail.** 170, fig. 557.
- Door-case.** Fig. 1788. 1. The frame which incloses or surrounds the sides and top of a door. The separate parts are the *door-jamb*s, or *door-posts*, *door-sill*, and *door-lintel*, which see.
2. A partition at the end of a street-car which incloses a sliding door when open. See *Fare-wicket door-case*.
- Door-case intermediate-rail** (street-cars). A rail of a door-case above the window.
- Door-case panel** (street-cars). A panel in a partition which incloses the sliding door. There are two, the top-panel and seat-panel.
- Door-case sash** (street-cars). A window-sash in the partition which incloses a sliding-door. It opens on hinges and is placed opposite to another in the end of the car inside of the door.
- Door-case sash-button.** See *Door-button*.
- Door-case seat-panel.** See *Door-case panel*.
- Door-case top-panel.** 194, fig. 5656. See *Door-case panel*. In some cases a mirror is used in place of a panel.
- Door-case top-rail.** A stick parallel with the *Door-lintel*, which see.
- Door center-girth** (freight-car doors). A horizontal board across the middle of the door. A *middle door-rail*, except that it is not framed into the door but simply nailed on.
- Door chain-bolt.** Fig. 2579. A device which permits a door to be opened a short distance, yet not far enough to gain admission.
- Door-check** (Norton's). Fig. 2818. An automatic device consisting of a piston in a cylinder, which forms a pneumatic cushion and prevents the door from slamming.
- Door fence-rail** (English). 118, figs. 501-4. A horizontal piece of wood forming, on the outside of the door, the bottom of the window aperture. It is reinforced with a band of brass or iron against which the window-sash bears when it is closed.
English carriage windows drop down to open, like an omnibus or street-car window.
- Door-frame.** Fig. 1783-93. The structure in which the panels of a door are fitted. It is composed, as is also a window-sash, of the *stiles*, or upright pieces at the sides; the *mullions*, or central upright pieces; the *bottom-rail*; the *lock*, or *central rail*, and the *top-rail*. The *Door-case*, which see, surrounds it. See *Fire-door frame*.
- Door friction-roller.** Figs. 2846-51. See *Sliding-door friction-roller*. *Car-door hanger*.
- Door glass-frame stop-rail** (English). 115, figs. 501-4. In a carriage, a small horizontal piece of wood in the lower part of the door against which the window drops when opened. See *Door-fence rail*.
- Door-guards** (baggage and freight-car sliding doors). 175, fig. 573. Strips of wood which inclose the space occupied by the door when open to keep the freight from interfering with its movement.
- Door guard-band** (street-cars). 140, figs. 5656. A metal band fastened crosswise on the middle door-rail to protect the door from being chafed. Also called a *sliding-door strip*.
- Door guard-rod.** 12, figs. 2442-5. See *vestibule door-rod*.
- Door-guide.** Fig. 2828.
- Door-handle** (freight-cars). 1. 78, figs. 229-66. A U-shaped wrought-iron bar attached to the door, sometimes horizontally and sometimes vertically. A *Sliding-door handle*, which see, is for passenger cars.
2. (English.) 181, figs. 501-3. Serves the purpose of an American *door-knob*. An L-shaped brass-bar attached to the outer end of a door-spindle, and conveniently shaped to be grasped by the hand, so that the door can be opened by a person either inside or outside the carriage.
- Door hand-rail** (street-cars). A rail attached to the inside of a door, that swings out, for passengers to take hold of in getting on and off the car.
- Door-hanger.** 21, fig. 1792, and figs. 2825-42. A hook-shaped piece of metal by which a sliding-door is suspended at its top, and which slides on an iron track at the top of the door. For freight-cars they are usually made of wrought-iron, but sometimes of cast-iron, with friction rollers, or sheaves, on which the door rolls. They are also used in sleeping and drawing-room cars, and are then generally made of brass and plated. The name of these more elaborate forms is commonly extended into *car-door hanger*, which see. See also *Anti-friction car-door hanger*.
- Door-hasp.** 73, figs. 229-66. A metal clasp attached to car-doors, by which they are fastened to a staple on the body of the car. Used chiefly on freight-car doors secured with a pin or bolt. They are now made of malleable iron and the pin fixed so it cannot be lost, as in figs. 3736-41. Padlocks are rarely used on freight-cars.
- Door-hasp pin** (seal-lock). A projecting lug on which a carefully shaped door-hasp enters, and is secured in place by the *clasp*.
- Door-hinge.** 1. See *Hinge*.
2. (English.) 178, fig. 501. Three brass hinges, upper, middle and lower, securing the door to the body. These hinges generally differ slightly to allow for the curvature or *fall-under* of the door.
- Door-holder.** Figs. 2803-14. A device for holding a door open or shut. They are also called *door-stops*, as they are also intended to check momentum of the door when swung open violently. *Lamp-case door-holder*. *Sliding-door holder*.
- Door-holder catch, or door-holder stop.** Figs. 2803-14. A metal bracket attached to the floor (*floor-stop*) or side (*partition-stop*) of a car, with which a *door-holder* engages, to hold a door open.
- Door-hook.** Figs. 2556-7. A *sliding-door holder*, which see.
- Door-jam.** 1, fig. 1788. The side piece or post of a door-case. Also called *door-post*. Not to be confused with the *stiles* of the door itself.
- Door-knob.** Figs. 2621-43. A ball attached to the end of the *spindle* of a door-latch to take hold of in moving the latch or opening the door. The knob is often made in various peculiar forms, as T *door-knob*, fig. 2643.
- Door-latch.** Figs. 2558-69. An attachment to a door to hold it shut. See *Latch*. A door-latch is often made in combination with a lock, having a separate bolt and key to secure or fasten the door from the outside, as in figs. 2637, 2653, etc.

- Door-latch arbor.** A *Door-latch spindle*, which see.
- Door-latch bolt.** See *Latch*.
- Door-latch hook.** Figs. 2558-69. The part of a *sliding-door latch* which engages with the keeper and holds the door shut.
- Door-latch keeper.** Figs. 2554-78. Also called *Strike-plate*, which see.
- Door-latch rose, or escutcheon.** Figs. 2644-81. A plate fastened to a door as a guard or bearing for the spindle. A *rose* is frequently called a *rosette*. See *Escutcheon*.
- Door-latch spindle.** 10, figs. 2631, 2639-41. A small metal shaft to which the door-handle or knob is attached, and by which the latch is turned.
- Door-latch spring.** A spring which acts on the latch-hook or bolt and causes it to engage with its keeper; usually made of a flat piece of cast-steel.
- Door-light (English).** 138, figs. 501-3. In a carriage, the window in the door which in English carriages is lowered to open it like an omnibus or street-car window.
- Door-light bottom sash-rail, or glass-frame bottom sash-rail (English).** 140, figs. 501-3. The bottom part of the door window framing.
- Door-light stile, or glass frame stile (English).** 141, fig. 501. The upright members of the window framing.
- Door-lintel.** 99, figs. 533-41. The horizontal part of a door-casing above the door. It is usually of wood, but in passenger-cars it is sometimes made of a thin shell of cast-iron. See *Door-frame*.
- Door-lintel backing.** 172, fig. 557.
- Door-lintel top-rail.** 99b, figs. 555.
- Door-lock.** Figs. 2631-2746. See *Lock*. A *latch*, which see, is usually combined with a passenger-car door-lock.
- Door-lock bolt.** See *Lock*.
- Door-lock keeper, or nosing.** See *Keeper*.
- Door-mullion.** 146, figs. 435-73; 2, figs. 1783-93. A vertical bar of wood between the panels of a door. See *Door-frame*. *Door-window mullion*.
- Door name-plate.** 3, fig. 1788. A metal plate on the inside of a passenger-car door with the name of the builder inscribed on it. This is now more commonly painted on.
- Door-panel.** 151, figs. 435-73; 10 and 11, figs. 1783-93. "A piece of board whose edges are inserted into the groove of a thicker surrounding frame of a door."—*Webster*. They are distinguished as *lower*, *middle*, and *upper*. Any panel, but especially the lower, is sometimes cut up into two *twin panels* by a *door mullion*, as in figs. 1783-4.
- Door-panel batten (English).** 109, fig. 501. American equivalent, *furring*. In a carriage, a piece which stiffens the *door-panel*, which is pinned to it.
- Door-pillar or door-stile (English).** 139, figs. 502-3. American equivalent, *door-stile*, which see. The outer sides of the stiles are beveled in a peculiar manner, so as to shut tight, and the inner sides are grooved to allow the movement of the window.
- Door-pin (freight-car doors).** 74, figs. 229-66, 355-72. A pin used to fasten a *hasp* to a *staple*. Leaden seals are sometimes attached thereto.
- Door-pin chain.** 75, figs. 244, etc. A chain by which a door-pin is attached to a car.
- Door-plate.** 3, fig. 1788; figs. 2773-82. A notice-plate. See *Door name-plate*.
- Door-post, or door-jamb.** 44, figs. 229-66; 62, figs. 435-73, 539-41; 1, fig. 1788. A vertical post which forms the side of a doorway.
- Door-post pocket.** 44, figs. 229-66. See *Pocket*.
- Door-pull.** Figs. 2580-81. A D-shaped handle attached to a door to take hold of in opening or closing it.
- Door-rail.** Fig. 1788. A horizontal member or bar of the framing of a door. The upper one, 4, is called the *top-rail*; the lower one, 5, the *bottom-rail*; 6, the *middle* or *lock-rail*; 7, the *parting-rail*. Minor variations often occur, as in figs. 1784-6 and 1790-1.
- Door-rail bracket (car-doors).** Figs. 1817-20. A bracket to carry top door-rail, serving as a guide for the door. See *Door track-bracket*.
- Door-roller.** Figs. 2846-51. Also called a *door-sheave*. The term *Door-roller* is applied to a flat tread wheel pivoted in a bracket and attached to the bottom of a door to roll upon a flat surface rather than a narrow track.
- Door-sash.** 12 and 13, fig. 1788. A wooden frame, containing one or more panes of glass, placed in a door. In some cases one of these sashes is made to slide, so that it can be opened for ventilation. They are distinguished as *lower* and *upper* door-sash. The lower sash is commonly movable for ventilation and held open by a *door sash-lift* or *bolt* entering into a *door-sash plate*.
- Door-sash bolt.** 14, fig. 1788, fig. 4465-9. A metal pin attached to a sliding-door sash to hold it in any desired position.
- Door-sash lift.** Fig. 4470. See also above.
- Door-sash plate.** Figs. 4450-1; and 15, fig. 1788. See above.
- Door-shaft (single-platform street-cars).** An iron shaft extending through the car for the purpose of enabling the driver to open the rear door. A *door-shaft lever* is attached at the front end, and a *door-shaft crank* at the back end, which is fastened to a slotted *door-shaft crank plate* on the door.
- Door-sheave, or sliding-door sheave.** 21, figs. 1792, 2825-42. A small wheel on which a sliding door rolls. It is usually placed at the top of the door and sometimes at the bottom also. It is carried in a *door-sheave holder*. A grooved casting called a *door-shoe* or *door-slide* is sometimes used as a substitute on freight-car doors, especially when the load does not rest upon the lower door-track. See also *Door-roller*.
- Door-sheave transom (street-cars).** 191, fig. 5656. A long narrow panel which is hinged and with catch so that access may be had to the car-door sheaves and track.
- Door-shoe.** 70, figs. 229-66. See *Door-sheave*.
- Door-sill.** 64, figs. 229-66. A cross-piece attached to the floor on the under side of a door-opening. In car construction the term is usually applied to an iron plate used under passenger-car and occasionally freight-car doors.
- Door-sill plate (English).** 208, figs. 501-3. American equivalent, *door-sill* or *door-sill plate*. A roughened brass wearing piece placed in the doorway entrance.
- Door-slide.** See *Door-sheave*.
- Door-spindle.** Figs. 2639-41. The bar passing through the door which carries the door-knobs.
- Door-spring.** Figs. 2815-18. An attachment to make doors self-closing. Three of the great numbers of devices in use are shown. *Double-action spring hinges*, figs. 2617-20, are in general used instead for the few doors requiring them.
- Door-stile.** 150, figs. 435-73; 8, fig. 1788. One of the two upright pieces on the outer edges of a *door-frame*, which see.
- Door-stop.** 1. A peg or block against which a passenger-car door strikes when opened, often provided with a rubber cushion, especially for swinging-doors. *Door-holders*, which both stop the door and retain it, are often called *door-stop*, as figs. 2803-14.
2. (Freight-car sliding doors.) 71, 72, figs. 229-66. Blocks or strips of wood or iron to restrain excessive motion. They are distinguished as *closed door-stop* and *open door-stop*.
- Door-strap (street-cars).** A leather strap or cord by which the back-door is opened and shut from the front platform. See *Door-shaft*.
- Door top-rail.** 113, figs. 501-3. See *Door-rail*.
- Door-track.** 65, 66, figs. 244-66, etc. A metal bar or guide which supports a sliding-door, and upon which it moves, or by which it is held in its place. They are either *top door-tracks* or *bottom door-tracks*. The former usually carry the weight of freight-car doors, being hung

- thereon by *door-hangers*. The lower track serves only as a guide for the *door-shoes*.
- Door-track bracket.** 67, figs. 244-66. An iron or wooden block, fastened to the side of a freight-car, to which a door-track is attached or which holds a sliding-door in its place. See also *Door-rail bracket*.
- Doorway.** The passage or opening formed by a *door-casing* which is closed by a door.
- Door-wedge and clasp.** Fig. 3827. A *postal-car* furnishing.
- Door-window mullion.** A middle upright bar. See *Door-frame*.
- Dope.** A mixture of waste, oil, and grease, for journal-box packing, which is not fluid.
- Double-acting spring hinge.** Figs. 2617-20. A device to permit a door to open either way and also to make it self-closing. They are from 2½ to 7 ins. in length of flange, 4 ins. being the most usual. They consist in their original form of a hinge on a hinge, the two opening in opposite directions. The "Utility" double-acting hinge is much like an ordinary butt-hinge, the tendency to restore the door to its normal position when opened in either direction being caused by a spring.
- Double-board roof.** Fig. 2379. See *Car-roof*. The upper layer of grooved boards is sometimes laid with the grooves under, so as to form a kind of tube between the two layers.
- Double brace-pocket.** 41, figs. 229-66. See *Pocket*.
- Double-chair.** Figs. 3922-5, 3955, 3974-6. A *twin car-seat*. Formerly two reclining-chairs combined in pairs to save room. They were used three abreast, two on one side and one on the opposite side of the aisle.
- Double-coil hot-water circulation** (Gold's car-heating system). Figs. 2996-7. A system of car heating in which the hot-water circulation does not differ materially from that of the Baker and other systems, but in which the water may be heated with steam from the locomotive, in the heater itself, instead of in a *drum* or *jacket*, as is done in the *Consolidated* and *Safety's* systems. This is accomplished by making the coils in the heater double; the smaller one, which is the steam pipe, being inside of the larger pipe coil which is a part of the hot-water circulation. This *double-coil* in the heater is a feature of all the *Gold systems* using hot-water circulating pipes. See *Gold's car-heating systems*.
- Double-coil jet-system** (Gold's car-heating system). Figs. 3003 and 3008.
A system of car-heating which combines the *drum* or *jacket* features with the jet or commingler system of injecting steam into the hot-water circulation. The steam is first sent through the inner or steam coil of the double coil in the *Baker heater* and then through an *annulus F* into the circulating pipe. The jet is so directed as to aid the circulation in the pipes. It is claimed to be noiseless. A feature of the system is the carrying of the steam pipe to the full height of the circulating-drum before it enters the coils of the heater.
- Double-coil nest-spring.** Fig. 5429. A *spiral-spring*, which see, with another inside of it.
- Double-cone lamp-globe.** Fig. 3434. See *Lamp-globe*.
- Double-deck stock-car.** Figs. 37, 75-6, 355-8. One with two floors, or stories, one above the other, for carrying sheep, hogs, etc. The intermediate floor is called the *upper floor* or *double-deck*.
- Double-deck street-car.** Figs. 5650-2. A street-car with seats on the roof, much used abroad and in increasing favor in the United States, especially in Philadelphia.
- Double-door.** 1. A door made in two parts. These are sometimes fasted together by hinges, so as to fold back on each other, figs. 1790-1, and sometimes each part is hinged to one of the door-posts. Sliding doors are also sometimes made in two parts, figs. 5656 and 5665.
2. (Fruit-car.) Fig. 257. Doors in pairs, one inside the other, as in refrigerator-cars, etc., are also called *double-doors*.
- Double elliptic spring.** See *Elliptic spring*.
- Double-guard** (lanterns). See *Guard*.
- Double iron body-bolster.** Figs. 1455-57. A common form for passenger-cars with six-wheel trucks, composed of two parallel iron trusses connected by iron plates or bars. It is sometimes applied to freight-cars, fig. 1448.
- Double-lens tail or signal-lamp.** Figs. 3324, etc. A lamp with two lenses on opposite sides. See *Signal-light*.
- Double-lever brake.** Fig. 1460. A brake which has two levers to a truck. The object of using two levers is to equalize the pressure on the two brake-beams. See *Brake-gear*.
- Double pipe-clip.** Fig. 2935. An iron band made with two bends for holding two pipes (as heater pipes) in their place. See *Clip*.
- Double plate-wheel.** Figs. 5259-60. A cast-iron car-wheel, the rim and hub of which are united by two cast-iron plates or disks. Wheels in which the double plates extend only part way between the hub and rim, the connection being made by a single plate, are often called *double-plate wheels*. Figs. 5316, 5349. See *Car-wheel*. *Wheel*. *Washburn Wheel*.
- Double ratchet** (Morgan's deck-sash pivot). Figs. 4385-8. A pair of radially ribbed disks which engage with each other in any position, there being no separate dog or ratchet-bolt. Another style of double ratchet, so called from its working when the sash is moved either way, is shown in fig. 4400.
- Double sash-spring.** See *Sash-spring*.
- Double sliding-door fixtures.** Figs. 2843-5, 5665.
- Double-spoke car-wheel.** Figs. 5294-5. See *Car-wheel*.
- Double strap-hanger** (for bell-cord). See *Bell-cord hanger*.
- Double-spring drawbar.** Figs. 2282-89. A form of drawbar in which two springs are used, either side by side or one in front of the other. In the latter case only one of the springs acts at once, one under tension and the other under compression. Drawbars with *auxiliary draw-springs*, are still another class, which are double springs *de facto*, but not so called.
- Double-spring drawbar-timber.** Figs. 369-72. Two timbers extending longitudinally from the needle-beams to the *follower plate-block*, bolted to and under the center-sills and connected thereto with *packing-blocks*.
- Double-track snow-plow.** Figs. 224, 408-9. A push-plow which plows the snow to one side of a track only, so as to not crowd it upon the other parallel track.
- Double-washer.** A washer that answers for two bolts. See *Twin-washer*.
- Double window-blind.** The usual form of window-blind. They are made in two parts, so as to require less height when raised. See *Window-blind*.
- Double window-blind lift.** Figs. 4435-7, 4445-7. See *Window-blind lift*.
- Dove-tail.** "A flaring tenon adapted to fit into a mortice having receding sides so as to prevent the withdrawal of the tenon in the directions to which it will be exposed to strain."—*Knight*. There are many forms of dove-tail joints.
- Draft-bar slide.** Draw-bar slide. (Street-cars.) 89, figs. 5654-67. A drawbar sector which supports the coupler end of the drawbar and over which it swings.
- Draft-bolt** (Janney coupler, which see). 157, fig. 2301. A *draft spring-bolt*.
- Draft-door** (Baker heater). Figs. 2868, etc. A door in the smoke-flue base, automatically opened and closed by the fire-regulator, and by which the fire is regulated.
- Draft-gear.** Figs. 1936-72 and 2275-2354. A term used to designate the drawbars, draft-timbers, buffing apparatus, and all their attachments—in short, the whole of the arrangements by which a car is drawn and which resists concussion. See the various heads above. Also *Drawbar*, *Draw-head*, *Draft-timbers*, etc.

Draft-gear check-casting. Figs. 2000-2. (Graham and Mitchell-Graham draft-rigging, which see.) A casting which inclose the *thimbles* or *followers*, and carries the thrust to the draft-sills and draft-timbers, with which they engage.

Draft-gear, freight. Figs. 1936-2243.

- “ “ (M. C. B.) Figs. 5499-5537.
- “ “ (automatic couplers). Figs. 2073-2243.
- “ “ (continuous). Figs. 1936-58.
- “ “ (link-and-pin drawbars). Figs. 2073-4.
- “ “ (English). Figs. 348-51.
- “ “ (Graham). Figs. 1959-75.
- “ “ (Graham-Mitchell). Figs. 1976-2006.
- “ “ (Butler). Figs. 2007-17.
- “ “ (Canda). Figs. 2018-26.
- “ “ (sundry railroads). Figs. 2027-72.
- “ **passenger** (Gould). Figs. 2296-00.
- “ “ (Janney-Buhoup). Figs. 2301-50.
- “ “ (Miller). Figs. 2290-5.
- “ “ (center-draft). Figs. 2282-89a.
- “ “ (English). Figs. 501-4.
- “ “ (Van Dorsten). Figs. 2275-6.
- “ “ (Thurmond-McKeen). Figs. 2277-81.
- “ “ (Leonard-Hydrostatic). Figs. 2351-4.

Draft-gear tie-rod. 163, fig. 463; 51, fig. 2291. A rod which connects an end-sill or platform end-timber with a body-bolster or drawbar cross-timber to tie them together. The term is sometimes applied to the continuous draft-rods that run from one *drawbar* to the one at the other end of the car.

Draft-iron (Janney coupler, which see). Fig. 2301. The equivalent of a *drawbar-jaw*, which see.

Draft regulator. See *Fire regulator*.

Draft-rod (continuous draw-gear). Figs. 1936-58. A rod which unites two drawbars at opposite ends of a car, and relieves the draw-timber attachments from strain.

Draft-sills. The *center-sills*.

Draft-spring. 1. 9, figs. 1936-2031, 2136-7; 28P, figs. 2301, 5235-6. A spring attached to a *coupler* or *drawbar* (which see) to give elasticity. They are usually so arranged by means of *follower-plates* at each end as to resist either tension or compression. The usual size for draft-springs is 5½ inches in diameter and from 6 to 8 inches in length, double-coil spiral springs. See *Auxiliary buffer-spring*.

In 1893 a Recommended Practice was adopted by the M. C. B. Association for attaching M. C. B. Automatic couplers to cars as shown in figs. 5507-37, and by a separate vote the use of a draft-spring 6¼ inches diameter by 8 inches long with 2½ inches motion and 22,000 lbs. capacity was recommended.

An occasional substitute for draft-springs in narrow-gage and other cheap cars is the *spring-end sill*, which see.

2. (English.) Figs. 349, 502. A long, half-elliptic spring reaching entirely across the car. Rubber draft-springs are more generally used, especially with continuous drawbars. Sometimes called a *draw-spring*.

Draft-spring casting (street-car). 93, figs. 5654-67. A sort of a *follower-plate* for a street-car *draft-gear*.

Draft-spring cradle-plate (English). 146, figs. 348-51. A longitudinal plate in the *under-frame*, which supports the *draw-spring*.

Draft-spring pocket. A *drawbar spring-pocket*, which see.

Draft-spring stop. A metal sleeve or thimble in the center of a spiral or volute draw-spring to resist excessive compression. Not to be confused with a *draw-bar stop*, which see.

Draft-timbers. 10, figs. 1936-2033. A pair of timbers, carrying the drawbar attachments, placed below the center-sills, and usually extending from the *platform end-timber* of passenger-cars, or the end-sill of freight-cars, to the body-bolster. In passenger-cars these timbers are usually the principal supports of the platform.

See *Platform-sills* and *Platform short-sills*. The draw-timber in a tip-car is also termed a *car-perch*.

Draft-timber lock-plate. Figs. 946-8.

Draft-timber pocket. A casting attached to the body-bolster or center-sills of a car to receive the end of a *draft timber*.

Draft-timber tie-bar. Figs. 1970-1. A transverse iron bar attached to the under sides of a pair of draft-timbers to tie them together.

Draft-timber tie-plates. Figs. 1267-8.

Draft-washer (Janney coupler). The washer for the rear end of the auxiliary draft-spring.

Drain-cock. (Of Westinghouse air-pump.) 41, fig. 1689, and 105, figs. 1691-2. A faucet attached to the lower end of the steam-cylinder to draw off water of condensation. See also *Reservoir drain-cock* and *Tender drain-cup cock*.

Drain-cup, or drip-cup (Westinghouse brake). 19, figs. 1706-7. A globular receptacle under a triple valve to collect water of condensation.

Drain-pipe union (Westinghouse air-pump, etc.). 41, fig. 1689.

Drake & Weir car-roof. Fig. 2392. See *Car-roofs*.

Drapery-curtains. D, figs. 2452-3a.

Drawbar. 1. (Link and pin.) An open-mouthed bar at the end of a car in which the *coupling-links* enter and are secured by a *coupling-pin*. They are provided with a *draft-spring*, which see, to give elasticity to the connection between the cars. Drawbars are made either of cast, malleable, wrought iron, or cast-steel, and in respect to their form are either (1) *bolt* or *spindle* drawbars, in which the draw-spring is attached by a bolt passing through its center; or (2) *spring-pocket* or *strap* drawbars, in which the draw-spring is inclosed within a yoke surrounding it. The elevated railroads use the *center-draft* drawbar, which see, figs. 2282-89a, attached directly to the center-pin of the car. The *solid-head* is a wrought-iron drawbar forged in one piece instead of having a drawbar face-plate riveted on. The drawbar is frequently called *draw-head*, especially cast-iron drawbars. With certain coal cars a cheap form of drawbar, called a *draw-hook*, is used. In England this style is almost universal in combination with plain links in freight-car service, and with a *screw-coupling*, which see, for passenger-cars. The drawbar of the *Miller* couplers is also very frequently called a *coupling-hook*. See below. See figs. 2007-2026.

2. The word *drawbar* is used indiscriminately to designate both the old link-and-pin drawbar and the modern *automatic car-coupler*. There has been an effort to confine the name drawbar to the old link-and-pin type, but in the Proceedings of the M. C. B. Association, in speaking of the height of drawbars, the term is manifestly applied to the M. C. B. standard automatic *coupler*. The general adoption of the word to mean the old link-and-pin drawbar is hardly desirable if it were possible; for the link-and-pin drawbar will in a few years, without doubt, be a thing of the past, which will end all confusion of terms. The standard height of passenger-car drawbars adopted in 1890 by the M. C. B. Association is 35 inches from the top of the rail to center of drawbar, where the car is light. The standard height of drawbar for freight-cars from level of top of rails to center of drawbar is 34½ inches, adopted in 1893, with no greater variation than 3 inches, minimum height 31½ inches. See *Automatic Car-coupler*, *Coupler*, and *Car-coupler*.

3. (Miller coupler.) The *drawbar coupling-hook*, 11, figs. 2290-2.

Drawbars and attachments (Rules for interchange of traffic). Figs. a-k in the text.

Drawbars and attachments shall be considered in bad order unless the following ten conditions are complied with:

1. M. C. B. couplers with such minor defects only as

do not impair their efficiency and safety. The following defects will not be considered as impairing the efficiency or safety of M. C. B. couplers:

A. Chipped to $1\frac{1}{2}$ in. vertically and $3\frac{1}{2}$ in. horizontally from outer edge of guard-arm, provided not less than 5 in. of metal is left intact on outer edge of guard-arm at A. (See fig. a.)

E. Chipped on lugs in which knuckle swings, to $\frac{1}{4}$ in. vertically, $\frac{3}{4}$ in. back, and 3 in. transversely, as shown in fig. e.

F. Having combination of chipped places within limits given above, as shown in figs. f and g, provided that defects shown in figs. a and b, do not together exist in the same coupler.

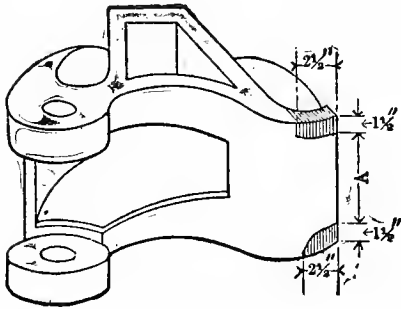

Fig. a.

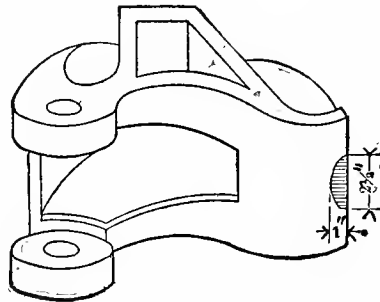

Fig. b.

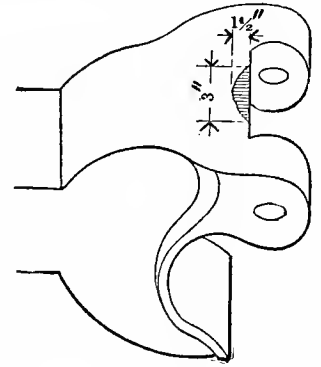

Fig. c.

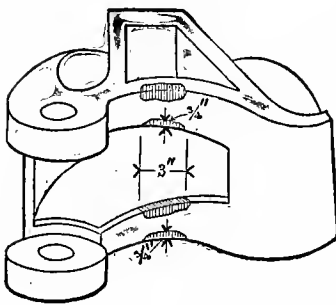

Fig. d.

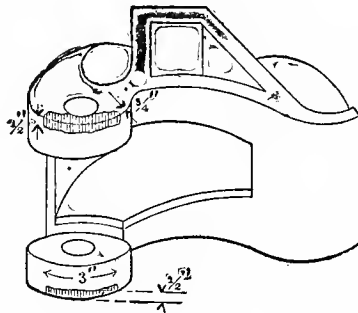

Fig. e.

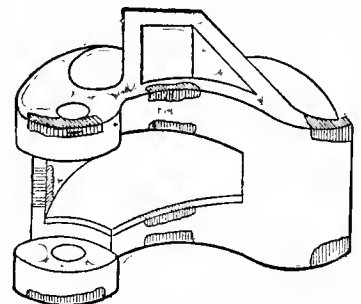

Fig. f.

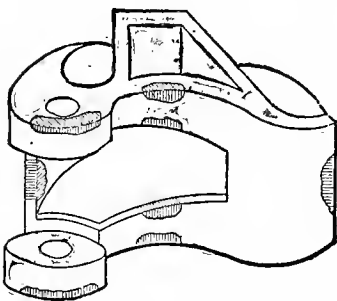

Fig. g.

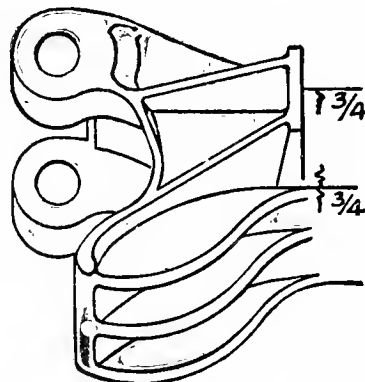

Fig. h.

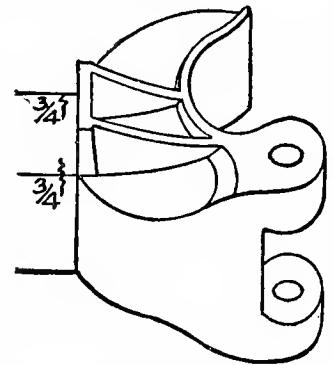

Fig. i.

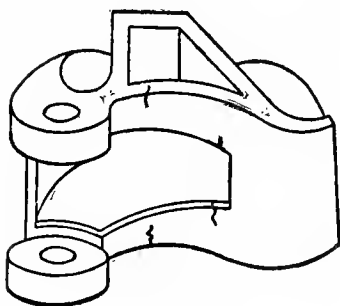

Fig. j.

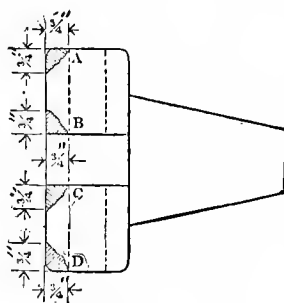

Fig. k.

B. Chipped to $2\frac{1}{2}$ in. vertically and 1 in. horizontally in center of guard-arm, provided both top and bottom corners are perfect. (See fig. b.)

C. Chipped on side wall to 3 in. vertically and $1\frac{1}{2}$ in. horizontally, as shown in fig. c.

D. Chipped on front wall or center front face to 3 in. horizontally and $\frac{1}{4}$ in. vertically in top, bottom, and throat, as shown in fig. d.

G. Having rib in front of locking-dog bent inward, provided rib is chipped off so as to allow dog to drop into position.

H. Having cracks at one or both top corners just behind the horn if such cracks do not exceed $\frac{3}{4}$ in. horizontally, or vertically, or both. (See figs. h and i.)

I. Having cracks in front walls or face of coupler, either at top or bottom, as shown in fig. j, provided these cracks do not extend back into the main body or horizontal walls of the coupler.

J. 1. Knuckles with lugs chipped to $\frac{1}{4}$ in. vertically and $\frac{3}{4}$ in. horizontally at A, B, C, and D. (See fig. k.)

2. M. C. B. couplers must be equipped with a steel or a wrought-iron knuckle.

3. Where wrought-iron drawbars are used they must not be broken off outside of tenons, nor broken nor cracked in the opening of face-plate, nor in the angles of the pocket, nor through rivet holes, nor must the filling be lost. Where cast-iron drawbars are used

they must not be broken nor cracked through pin-hole nor back of head, nor must bolts or rivets be missing where wrought pocket is used.

4. Drawbar stem, rod, and bolt must be sound and secured back of drawbar follower-plate by a nut or flat key. This to be secured by either a ring or spring cotter.

5. Drawbar stops must be sound, with all bolts and nuts in proper place.

6. Drawbar keys and followers must be sound, keys secured by cotter or ring, and followers held in proper place by drawbar-guides.

7. Draft-springs composed of two or more coils must not have more broken parts than one inside coil.

8. Drawbar carrier-irons should have two effective bolts on each side.

9. Draw-timbers must not be more than $\frac{3}{8}$ in. down, and this only where bolts are effective.

10. Dead-blocks, wood sound, castings free from cracks through bolt-holes and properly secured in place with bolts or rods.

Drawbar attachments and dimensions. Figs. 5506-37. In 1893 a Recommended Practice was adopted for attaching M. C. B. automatic couplers to cars, as shown, and by a separate vote the use of a draft-spring $6\frac{1}{2}$ inches diameter, 8 inches long, with $2\frac{1}{2}$ inches motion and 22,000 pounds capacity was recommended.

Drawbar bolt. 14, figs. 1936-2033; 5, fig. 2031. A bolt or spindle which connects a drawbar to a draw-spring and follower-plates, passing through the center of the latter. A *tail-bolt*. See *Drawbar*.

Drawbar carry-iron. Figs. 2218, 2281, 5507. A transverse iron bar bolted to the under side of the *draft-timbers*, and on which the drawbar rests. It is usually U-shaped, and the ends are bolted to the end-sills, but sometimes flat, with *draft-timber guards* at the side, figs. 1968-9. A drawbar carry-iron is sometimes called a *stirrup*.

Drawbar chafing-plate (Miller coupler). An iron plate framed into the *platform truss-beam*, 22, figs. 2290-2, above the drawbar coupling-hook, to protect it from abrasion.

Drawbar coupling-hook (Miller coupler). 11, figs. 2290-2. The Miller *drawbar*, which see.

Drawbar distance-piece (wrought-iron drawbars). A block of iron between the upper and lower plates. In many cases it serves as a thimble for the rivets.

Drawbar follower-plates. 7 and 8, figs. 1959-2004, 207-9. The term is misused as applied to 8A. The piece marked 8A should be called a *check-casting*. Two iron plates which bear against each end of a draw-spring, and transmit the tension and compression on the drawbar to the draft-springs and to the draft-timbers. See *Auxiliary drawbar follower-plate*.

Drawbar friction-plate (street-cars). A cast-iron plate through which the drawbar passes, attached to the platform end-timber, to protect it from abrasion.

Drawbar guides. 12, figs. 2293-5, also shown in fig. 2299. Wrought-iron bars which are fastened in pairs to the top and bottom of the lugs or *stops* bolted to the draft-timbers on each side, forming guides in which the *drawbar follower-plates* move. A *drawbar jaw*, which see, is sometimes used as a substitute for both the guides and stops.

Drawbar guide. Cast-iron lugs, or wrought plates, bearing against the sides of draft-timbers over the *drawbar carry-iron*, to resist lateral strains and protect the draft-timbers from wear.

Drawbar head (wrought-iron drawbar). 3, fig. 2074. The outer end of a drawbar, which bears against a similar head on the adjoining car.

Drawbars, Height of (M. C. B. Standard). The standard height of drawbars for passenger equipment cars is 35 inches from top of rail when car is light. Adopted in 1890.

The standard height of drawbars for freight-cars,

measured perpendicular from the level of the tops of rails to center of drawbars, adopted in 1893, is $34\frac{1}{2}$ inches, with no greater variation allowable than 3 inches, minimum height $31\frac{1}{2}$ inches.

Drawbar horns (Janney-Buhoup platform). 49, figs. 2440-5.

Drawbar packing-blocks. 186, figs. 229-66; 11, figs. 1959-2009. A rectangular piece gained into the draw-timbers and center-sills and serving to prevent longitudinal movement. See *Packing-block*.

Drawbar pin (street-cars). A coupling-pin.

Drawbar pocket (strap or spring-pocket drawbars). Figs. 2005-6. A *drawbar spring-pocket*, which see.

Drawbar safety-lug. Figs. 2075-2243. A horn on the upper side of a drawbar to bear against the end-sill on a single dead-block on the end-sill, to relieve the draft-spring, etc., from excessive buffing strains.

Drawbar sector (center-draft draw-gear). 20, figs. 2288-9a. A guide for the drawbar, shaped like an arc of a circle, fastened underneath the platform.

Drawbar side-casting. Figs. 2015-17, 2025, and in fig. 2031. An iron casting, of which a pair serve as combined *drawbar guide* and *stop*, which see, for the followers to hold them in their places. A *drawbar-jaw* is a wrought-iron substitute and equivalent.

Drawbar side-spring. Fig. 2218. A spring attached to the *stirrup*, or drawbar carry-iron, to give the drawbar the necessary lateral motion in coupling. It takes the place of the Miller *leaf-spring* or *coupling-spring*.

Drawbar spindle, or stem. 14, figs. 1936-2033. The *drawbar bolt* which passes through the center of the draw-spring and follower-plates in a bolt or spindle drawbar.

Drawbar spring-pocket. 6, figs. 1936-2033. The space at the back end of a spring-pocket or strap drawbar which receives the draft-spring and follower-plates.

Drawbar stem. A *drawbar bolt*, or tail-bolt, which see.

Drawbar stirrup. A *drawbar carry-iron*, which see.

Drawbar stop. A casting which limits the movement of the drawbar-followers, bolted to the draft-bar timbers and forming distance-pieces to which the *drawbar-guides* are bolted. The castings for the drawbar-stop are sometimes made long enough to bear against the body-bolster, or a filling-block interposed between it and the drawbar, thus relieving lugs and bolts of strain.

Drawbar stop-block. Figs. 661-2.

Drawbar washer (logging-cars). A follower-plate on a small scale.

Drawbar yoke. 1. A *drawbar carrying-iron*, which see.

2. The yoke or *strap-pocket* that incloses the draft-spring and is bolted to the end of the drawbar is also called a *yoke*.

Drawbar-yoke filler. See *Drawbar-yoke guide*.

Drawbar yoke-guide. Figs. 1993-5. A casting that fits into the rear-thimble and transmits the draft from the yoke to the thimble and thence to the spring. A *drawbar yoke-filler*.

Draw-chain (English). See *Wagon coupling*.

Draw-clevis (street-cars). A wrought-iron bar with forked end attached to the platform, to which the horses are attached. Two kinds of these are used, one fastened to the platform so as to be immovable; the other, a *spring draw-clevis*, can slide lengthwise, and its motion is resisted by a spring.

Drawer-pull. A wooden or metal attachment to a drawer to take hold of in pulling it out. In postal-cars they are combined with label-holders, figs. 3829-30.

Draw-head. The head of an M. C. B. coupler exclusive of the knuckle, knuckle-pin and lock. See also *Drawbar-head*.

Draw-hook. 1. (Coal-cars and street-cars.) Figs. 343-4a. An iron hook attached to the end of a car, by which it is drawn and by which it is coupled to other cars.

The Miller draw-hook is called the *drawbar coupling-hook*, which see.

2. (English.) 40, figs. 348 and 501. A strong hook at the end of the drawbar, which receives the link of a coupling-chain of the adjoining vehicle, in order to transmit the draft. A precisely similar arrangement to that used on many American coal-cars. In England, universal for freight-cars (goods-wagons). A *screw-coupling*, which see, is generally used on passenger-cars (carriages).

Draw-hook washer, or drawbar front-plate (English). 145, figs. 348-51. American equivalent, *draw-hook plate*. A wrought or cast iron plate secured to the *head-stock*, guiding the drawbar and receiving its rebound.

Drawing-room car. Figs. 111-117, 162, 178, 190. A luxurious passenger-car for day travel, furnished with arm-chairs, sofas, carpets, etc. An extra charge is usually made to passengers who travel in them, and they are run by separate companies, like sleeping-cars, under contract with the railroads. Also, and perhaps more commonly, termed *parlor-car* or *chair-car*, which see; sometimes extravagantly *palace-car*. See *Bay-window parlor-car*.

Draw-off cock (Baker heater). Fig. 2957. A cock attached to the pipe, R, for emptying the pipes. It is a *combination cock*, which see.

Draw-spring. See *Draft-spring*.

Draw-timbers. See *draft-timbers*.

Dressing-room. Fig. 3468 and 3545-7. Another name for a *saloon*, especially one provided with wash-bowl and toilet facilities. The ladies' saloon of sleeping and parlor cars is commonly so fitted.

Drexel car-coupler (freight). Figs. 2112-24. Passenger, figs. 2244-5.

Drexel journal-box-lid. Figs. 5172-5.

Drexel roller-side-bearing car-truck. Figs. 4747-9. See *Roller side-bearing truck*.

Drexel vestibules. See the *Barr vestibules*.

Drilling. A term used in New Jersey for *switching*, which see, or making up trains. *Regulating* is another term sometimes used. The English term for this is *marshaling* or *shunting*.

Drip. 1. A receptacle to collect waste or superfluous liquid, as the *water-drip* of a water-cooler. See *Urinal drip-pan*, fig. 3873.

2. (Dining-car kitchens.) A lower sink receiving the drainage therefrom.

Drip-cock (Westinghouse brake). Fig. 1718. The cock at the bottom of the drip-cup.

Drip-coupling, or basin-coupling (wash-basin). Fig. 3474. The *connection* of the waste-pipe or drip-pipe with the basin.

Drip-cup. 1. (Westinghouse brake.) Figs. 1719, 1758-60. A receptacle inserted in the brake-pipe of each car to receive water condensing therein. A *drain-cup*.

2. (Student-lamp.) D (or 20), figs. 852-4.

Drip-cup screw (Student-lamp). E, fig. 3399.

Drip-dish (refrigerator-car). A dish or pan at one corner or end of the car for receiving the water from the melting ice, usually permitting it to escape by a *trap*, which see.

Drip-pipe (alcove). Fig. 3553.

Drip-tray. Figs. 3860-1. An enameled piece of sheet-iron placed directly under the seat of a closet, and over the bowl.

Driver-brake tie-rods. 21, figs. 1699, 1707. See *Brake-block pin-rod*.

Driving-chain (pile-driver car). 43, figs. 401-4. A *pitch-chain* (which see) used to make the pile-driver car self-propelling, by engaging with the *pitch-gear* attached to one of the axles. Such cars are not usually made self-propelling.

Driving-gear (lever hand-car). 4, 5, figs. 5592-5600. It consists of the spur-wheel, or gear-wheel, and pinion.

Driving-wheel brake, or driver-brake (air-brake). Figs.

1747-9. A brake applied to the driving-wheels of a locomotive. They are in very general use on locomotives in all kinds of service. All of the air-brakes are or may be so applied. A brake, manufactured by the American Brake Co., has also been quite largely introduced, but this brake apparatus now employs air instead of steam. The two forms of brakes illustrated are the ones in most general use and in highest favor.

Driving-wheel brake-cylinders (Westinghouse). Fig. 1748. (American Brake Co.) Fig. 1749.

Drop (of lamp). "The drop of a center-lamp is its extreme length," measured from the ceiling to the lowest part of the lamp.

Drop-bottom. See *Drop-door*.

Drop-bottom car. Figs. 20-26, 31, 298-326. A car so constructed that its contents can be readily unloaded from the bottom by means of drop-doors.

A distinction is sometimes made between *hopper-bottom* cars, figs. 21-23, 305-24a, 325-7, which will discharge nearly all their contents without assistance, on opening the drop-doors; and a *drop-bottom* car, as figs. 21-23, 298-304, will not do this.

Drop-bottom cars are usually gondola-cars.

Drop-bottom car, brake for. Figs. 25, 310-19, 1459, 1731, etc. A brake specially arranged to have no parts under the center of the car to interfere with the drop-doors. See *Brake* and *Brake-gear*.

Drop-door. 61, figs. 298-315. A door at the bottom of a drop-bottom or hopper-bottom car for unloading it quickly by allowing the load to fall through. Drop-doors are usually, if not invariably, in pairs, and are supported by a *drop-door chain* wound upon a *winding-shaft*, which see. A *drop-door beam* extends across the car above the winding shaft to assist in supporting it and to stiffen the car. The subject of *drop-doors* has received a great deal of attention of inventors, and numerous designs and devices have been patented, yet the original drop-door with winding-shaft and chain is in very general use. Two other designs are illustrated—*King's door*, and the *Canda slide-door*—both of which possess novelty, and are in service on a considerable number of cars, especially the former.

Drop-door beam. See above.

Drop-door chain. 64, figs. 298-315. A chain attached to the *winding-shaft* and the *drop-doors*, which see. Also termed *hopper-chain*.

Drop-door hinge. 62, figs. 298-315. See above.

Drop-down frame (seat-cushions). Fig. 3906. One made so as to drop the slats supporting the seat-springs below the level of the seat rails so as to enable higher and easier springs to be used. The same thing is also effected by using curved *seat-slats*, as in figs. 4006-7.

Drop-forging. One made under the drop-hammer by the use of a die.

Drop-table (dining-car kitchens). A table hinged to the wall so as to drop against it out of the way when desired.

Drop-letter-box plate. Fig. 3820-2. A *letter-drop*, which see.

Drop-rack (Hartley chair). 4, figs. 3998-9. A rack by which the position of the back of the chair is regulated.

Drum. 1. "A cylinder over which a belt or band passes.

2. "A chamber of a cylindrical form used in heaters, stoves, and flues. It is hollow and thin, and generally forms a mere casing, but in some cases, as steam-drums, is adapted to stand considerable pressure."—*Knight*. See *Brake-shaft-drum*, *Circulating-drum*, or *Expansion-drum* (Baker-heater).

3. (Hoisting-gear.) 7, figs. 389-96; 41, figs. 401-4. The main cylinder upon which the hoisting-rope is rolled up. The *spur-wheel* is carried on the same shaft.

Drum-cover. 1. (Baker-heater.) Fig. 2933. A sheet-iron covering for the circulating-drum on the outside of the car.

Drums for direct storage (Consolidated car-heating). Figs. 2961-7. A pipe containing salt-water, or a solution of acetate of soda, placed within a larger pipe,

the steam being admitted to the space between the two pipes. The outside pipe is therefore heated with steam. When steam is shut off, the heat from the inner tube containing salt-water, or solution of acetate of soda, maintains the temperature in the outer pipe. The two pipes at one end connect into the same fitting through which access is had to the space within the inner tube as well as the space between the tubes, so that the inner tube may be charged with salt-water, or with solution of acetate of soda, after the drum is made up and placed in position in the car.

Drum systems of car-heating. This method of heating employs a hot-water circulation within the car, to which a "Baker" or other similar heater is attached. To provide a means for maintaining heat in the car when steam from the locomotive is used, a drum is employed to transfer the heat of the steam to the water of circulation. Simple forms of drums are shown in figs. 2961-7, 3039-42, 3051-5, which consist simply of a cylinder or pipe within another pipe of larger cross-section, provision being made for the unequal expansion of the pipes; and outlet and inlet orifices being provided for the circulation of the steam and water.

Another type is the *coil-drum* or *coil-jacket*, figs. 3043-5, which see, which generally consists of a large sized pipe or casting capped at both ends. In this drum is placed a coil of copper pipe, which coil is made a part of the hot-water circuit within the car. Steam from the locomotive is admitted to this drum around the copper coil, through which heat is imparted to the water of circulation. That part of the circuit above this drum becoming relatively lighter than the water of the circuit, a movement of the circulating medium is produced, creating a steady flow up through the coil. The amount of heat communicated to the circulating medium depends upon the surface of the coil and upon its conductive power to heat. A pressure of from 10 to 20 lbs. of steam is carried in the drum. See also *Double-coil systems*. *Gold's systems car-heating*. *Safety car-heating*.

Drummond fastening (English). Fig. 5313. As applied to railroad wheels, a mode of securing the tire to the wheel, which prevents their coming asunder should the tire break or become loose. The tire is turned to the dotted line on the left hand of the figure, and when hot is hammered into shape shown in full lines in section, securing the *retaining-ring* in position. See also *Tire-fastening*.

Drum-shaft (of a derrick or crane). Figs. 389-96. The shaft on which the winding-drum is carried.

Drum-support (Baker-heater). A bracket on the roof to hold the circulating-drum.

Dual-burner. Figs. 3367-8. A coal-oil lamp-burner with two wicks, each in a separate-tube, by which a double flame is obtained. The *Taber* burner has two wicks in a single tube.

Duck. A flax fabric, lighter and finer than canvas, for use in car upholstery. It is usually manufactured in rolls 18, 24, and 40 inches wide and about 40 yards long. *Roofing-duck* (used for street-car roofs) is manufactured of many different widths up to 12 feet, so as to entirely cover the roof when desired.

Dudgeon's hydraulic jack. Figs. 3745-6. See *Jacks*. A jack with a base and head, and two cylinders, one cylinder sliding within another. To the inner one (which is termed the ram) is attached the head having a socket to receive the lever which operates the force pump in the lower end of ram; the remaining space is the reservoir containing the liquid which when forced into the lower chamber causes the ram to rise, and to lower, when allowed to return through the lower valve and back passages which are operated by the same lever. These jacks are light, portable, and easy of application, worked by one man; who can lift 20 tons 1 foot in 3 minutes.

Dummy coupling-hook (M. C. B. Recommended Prac-

tice). Figs. 5579-80. In 1894 a Recommended Practice was adopted of enlarging the point of the hook on dummy couplers for air-hose, to prevent damage to gaskets by improper use of the dummy coupling-hook.

Dump-car. A term used to designate both *drop-bottom*, *side-dump*, and *tip-cars*, which see.

Dunham storm-proof car-door. Figs. 1807-16.

Duplex double-coil jet-system (Gold's car-heating systems). Figs. 3005, 3006-8. A system using two *double-coils* (which see) in a Baker-heater and also employing a jet in the circulating-pipes to promote the circulation. The duplex-double coils are plainly shown in fig. 3006, and the jet, *M*, fig. 3006, and in fig. 3008. In consequence of the jet an overflow pipe, *P*, is necessary to carry off the increase of water from the condensation of the steam blown into the circulating-pipes. The arrows and letters plainly show the circulation of the steam and hot water.

Duplex double-coil overflow system (Gold's car-heating system). Figs. 3002, 3004-5. A system of heating which employs two double-coil steam jackets in a Baker-heater, to the inner coils of which steam is admitted. Each of the coils is connected independently with the return pipes from one side of the car, making two complete circulations. It may be understood from the figure, the arrows and the lettered parts showing the circulation and names of parts.

Duplex ventilator. Fig. 4308. See *Ventilators*.

Duplicate elliptic-spring. Fig. 5232. A double elliptic spring, which see.

Dust-arrester (of Pintsch gas pressure-regulator). A cavity closed at each end by a perforated plate to prevent dust entering to clog the regulating-valve.

Dust-collar. 9, figs. 5146-9. A grooved wrought-iron ring sometimes but not generally placed on a car-axle between the hub of the wheel and the journal to receive and hold a dust-guard. It is a feature of the *Adams journal-box*.

Duster. See *Feather-duster*.

Dust-guard. 15, fig. 5133; fig. 5154; 10, figs. 5146-9.

A thin piece of wood, leather, felt, or vulcanized fiber, inserted in the *dust-guard chamber* at the back of a journal-box, and fitting closely around the *dust-guard bearing* of the axle. It is to exclude dust and prevent the escape of oil and waste. Sometimes called *axle-packing* or *box-packing*. See *American* and *Stier dust-guards*.

Dust-guard and check-valve (Frost system of car lighting). Figs. 3112-13. The air from the auxiliary reservoir, of the *air-brake service*, enters this valve from the direction indicated by the arrow and passes through the *valve-body*, 1, and *air-inlet-pipe*, 5, into the dust-cup, 2, where is deposited dirt which the air has carried along with it. After forcing its way through the *felt-dust-screen*, 6, the air reaches the chamber directly beneath the valve-disc, 9. If its pressure is sufficient, it raises the *valve-disc*, 9, against the resistance of the spiral *valve-spring*, 10, and, passing out beneath the *valve-disc*, takes its course through the chamber to the *air-tank*. When the pressure is reduced in the auxiliary reservoir, the pressure in the *air-tank* acts upon the *valve-disc*, forces it firmly against the seat, thus prevents the leakage of air from the tank.

Dust-guard bearing (of an axle). See above.

Dust-guard chamber (of a journal-box). 15, fig. 5133. See above.

Dust-guard spring-holder. Fig. 4533. See *Window dust-guard* or *deflector*.

Dust hand-hole (street-car). An opening in the *door-casing*, which see, under the seat, to give access to the space into which the door slides, for the purpose of removing dirt.

Dutchman. A block or wedge of wood driven into a crevice to hide the consequences of bad fitting in construction. A kind of *shim*.

E

Eames vacuum brake. Figs. 1661-87. A system of continuous brakes, invented by Fred. W. Eames, operated by exhausting the air by an *ejector*, which see, from behind flexible india-rubber *diaphragms* attached to each truck. These diaphragms are directly connected to the brake-levers, and the pressure of the air on the outside of the diaphragms is thus communicated to the brake-shoes. The rubber diaphragms cover the mouth of a large cast-iron *diaphragm-shell* or bowl.

This brake is in use on the New York Elevated roads, on which the number of stops is very great, and on several other lines. The advantage of the plan is its simplicity. The disadvantage, especially for high-speed trains, is that it does not act so quickly as the Westinghouse automatic.

Ear. A general name for projections to which handles or other exterior parts are attached, but more especially applicable to projections intended for movable attachments. See *Ear* to padlock; and *Ear-bail*, below.

Ear-bail (lanterns). Figs. 3353-62. An attachment formed of wire connected with the wire-guard, to which the bail is attached instead of to the body of the lantern.

Earthen-hoppers. Figs. 3865.

Eastlake style. A style of ornamentation consisting of lines intended to indicate structural features, or some idea appropriate to the construction. The expression is also loosely applied to any style of construction where the framing is exposed to view, and made ostentatiously strong. It had its origin in Charles L. Eastlake's book, "Hints on Household Taste." *Queen Anne* style is an entirely different thing, though the two are often improperly confused.

Eastman heater car. See *Heater car*.

Eaves fascia-board. 1. (Freight-cars.) 91, figs. 229-66, 355-72. A plain board connecting the sheathing with the roof.

2. (Passenger-cars.) 92, figs. 539-41; 93, figs. 542-69. A projecting board on the outside of the lower deck, immediately under the eaves, which comes below and under the *eaves-molding*.

Eaves-molding. 1. (Freight-cars.) 90, figs. 229-66, etc. A plain strip sometimes used outside an *eaves fascia-board*, which see.

2. (Passenger-cars.) 93, figs. 539-41, etc. An ornamental finish to the exterior angle of the lower deck, outside of and above the eaves fascia-board. A similar *deck eaves-molding* is used for the upper deck.

Eccentric-lever (Westinghouse driving-wheel brake). 13, fig. 1747. An arm consisting of an *eccentric-lever casting* and screw, or *eccentric-lever stud*, one end of which is attached to a brake-head and the other connected with the piston-rod by the *eccentric-lever links*. The end or head of the casting is made of a cam-shaped or eccentric form, and bears against another lever of the same kind, so that, when the two are forced downward, the brake-shoes are forced against the driving-wheels. The stud or screw is intended to either lengthen or shorten the lever so as to adjust the pressure of the brake-shoes against the wheels when the shoes become worn. Also called a *cam*.

Eccentric-lever casting. 15, fig. 1747. See above.

Eccentric-lever links. 28, fig. 1747. See above.

Eccentric-lever nut. 18, fig. 1747. A lock-nut which screws on an eccentric-lever stud. See above. Also called a *cam-nut*.

Eccentric-lever stud. 19, fig. 1747. See above.

Eccentric pivot-plate (for seat-arms). A *seat-arm pivot-plate*, made eccentric only to get room for screw-holes. The eccentricity has no functional purpose.

Edge-rolled spiral-spring. Fig. 5252. A spring formed by rolling a flat bar edgewise. See *Spiral-spring*.

Egg-shaped lamp-globe. Fig. 3432. See *Lamp-globe*.

Egg-shaped stove. A stove resembling an egg in form.

It is commonly known simply as a *cast-iron stove*, and is very largely used for cabooses, etc., where appearance is not important.

Eight-group spiral-spring. Figs. 5221-2. See *Spiral-spring*.

Eight-wheel car. The standard type of American rolling-stock, consisting of a car-body carried upon two *trucks* or *car-trucks* (both of which see) of four wheels each. A considerable number of four-wheeled coal-cars and a very few four-wheeled box-cars are in use. Sleeping, parlor, and dining cars are twelve-wheeled. Even sixteen-wheeled cars have been built, but *car* always means in America an eight-wheeled car unless otherwise specified.

Ejector. Figs. 1663-68. An appliance for operating a vacuum-brake by exhausting or "ejecting" air. It consists essentially of a pipe, 1, fig. 1664, placed in the center of a surrounding shell or casing, 2, with an annular opening, 3, between the pipe and the casing. When a current of steam is admitted at the lower end of 1, and escapes at the upper end, the air in the casing at 4 is drawn out through the annular opening by the current of the escaping steam. The space 4 is connected by a pipe 5 with the appliances on the cars for operating the brakes. Suitable valves are also used in connection with the ejector to shut off and admit steam and air. Ejectors are very noisy. In the ejector for Eames vacuum brake, a *muffler* is used to render noiseless the escaping steam. It consists simply of a box of small round balls, like shot, through which the steam must pass to escape.

Elastic fiber journal-packing. A compound, principally of cocoanut fiber mixed with jute, to serve as a substitute for waste. It is lighter, cheaper, and claimed to be more effective.

Elastic wheel. Any car-wheel in which some elastic material is interposed between the tire and the wheel-center or hub to resist the concussions. Different substances are used, such as paper, wood, india-rubber, oakum, etc. English passenger-wheels are made of teakwood (fig. 5320) to effect this purpose.

Elbow. Fig. 2947, etc. A short L-shaped cast-iron tube for uniting the ends of two pipes, generally at right angles to each other.

Elbow-rail (English). 108, fig. 501. In a carriage, a part of the body framing running horizontally along the sides at about the height of the elbow of a passenger in a sitting position.

Elbow-rest (English). See *Folding arm-rest*. *Side arm-rest*.

Elder brake. Fig. 1462. A brake for eight-wheeled cars, with a horizontal *center brake-lever* in the middle of the car connected to the brake-shaft, having a fixed fulcrum under the car-body and pulleys at each end, over which a chain passes. The *live lever* (which see) of each truck also has a pulley or *brake-lever sheave* at its end, over which the same chain runs to apply the brakes. In very limited use.

Electric-car. An *electric motor-car*.

Electric lighting. Various plans for the lighting of car by electricity have been tested with promising success, but none of them as yet has obtained general introduction. The system that has been longest in use and most satisfactory on the whole is that shown in fig. 149, where the plant, consisting of an engine and dynamo, installed in one end of the baggage-car, the steam being taken from the engine. This system has been in use for several years with the Pullman Palace Car Company, and on the Chicago, Milwaukee & St. Paul Ry. Numerous attempts have been made to connect the dynamo with the axle of cars, one of the latest being a method of attaching the dynamo directly to the axle. These systems are yet in the experimental stage and no illustrations of them are given, as it is impossible to say what prominence they may gain.

Electric motor-car. Figs. 5643-4, 5646-9, etc. A car which is propelled by an electric motor, which is carried on the axle and truck and is geared to the axle and wheels. Such cars are also described as *Trolley-car*, if they receive the current from a live wire through a trolley which is kept in contact with it; or as *Storage-battery cars* if they carry and derive the current for their propulsion from a storage battery.

An excursion in a *Trolley-car* is popularly known as a "trolley party," and special cars have been designed for such parties, as shown in fig. 5644.

Electrolier. Figs. 3381-2, 3305-7. A chandelier of electric lights.

Elliott car-coupler. Figs. 2125-40.

Elliptic seat-spring. See *Seat-spring*.

Elliptic spring. Figs. 5229-34. A spring of elliptical form made of two sets of parallel steel plates of constantly decreasing length. Such springs are generally used for bolster-springs for passenger-cars. Their use in freight service has been practically abandoned in favor of spiral springs. *Half-elliptic* springs, are for locomotive springs. In England they are almost the only bearing-spring used, and are also used as *draw and buffing-springs*, which see.

The *set*, 2, fig. 5230, of elliptic springs is the total amount of bend or compression of which the spring is capable. The *arch* differs from half the set by the amount of the thickness of the spring-band. The connection between the two halves of the elliptic spring at its extremities is termed the *scroll*. Elliptic springs in service are termed double or *duplicate*, triplets or *triplicate*, *quadruple*, *quintuple*, *sextuple*, etc., according to the number of springs used side by side and connected by a single eye-bolt so as to constitute practically one spring. In passenger-car service elliptic springs are usually triplicates, quadruples, or quintuples. The *length* of the spring is the distance from center to center of scrolls when unloaded; and the *height*, the height over all unloaded. See figs. 5230-1.

EE-lock (Freight-car doors). Q. & C. Co. Figs. 2747-9.

E-lock (Freight-car doors). Q. & C. Co. Fig. 2758.

Emergency candle-lamp. Fig. 3295. See *Pintsch-bracket candle-lamp*. *Candle-lamp*.

Emergency-valve (triple-valve). 10, figs. 1706-7. See *Triple-valve*.

Emergency-valve piston (triple-valve). 8, figs. 1706-7.

Emergency valve seat (triple-valve). 9, figs. 1706-7.

Emergency tool-box. T, fig. 540. See *Tool-case*.

Emigrant-car cook-stove. A form of car stove used only on emigrant-cars, designed for cooking or heating food as well as for warming the car.

Emigrant car-seat (for day-car.) Fig. 3995.—(For sleeping-car.) Figs. 2413-17.

Emigrant sleeping-car. Figs. 505-11. A cheaply finished car without springs or mattresses, but in other respects similar to ordinary sleepers, for the use of emigrants. Now used chiefly on the long runs west of Chicago, and to some extent used for ordinary travel, especially by parties of excursionists.

Enclosed step (street-car). A step which is covered or enclosed by a sheet-iron apron attached to a swinging-door to prevent persons from riding on the step.

End arch-rail (English). 99, figs. 501-4. American equivalent, *end-plate*. A piece of timber run across the upper portion of the end of the body, its upper side being cut to the curve of the roof which it supports.

End ascending-step (English). 174, figs. 501-4. See *ascending-rail*.

End belt-rail. 50, figs. 229-66. (Freight-car.) A belt running across the end of a car about midway between the sills and plate, and with the side belt-rail forming a continuous girth around the car except across the doors. It is usually the top of the inside lining and is framed into the posts and braces. See *End-girth*.

End belt-rail tie-rod. 51, figs. 229-66. A *tie-rod* parallel to and alongside of the *end belt-rail* to keep the posts drawn tight and close against the *end-belt-rail*.

End berth-rest, or single berth-rest (emigrant sleeping-berths). N, figs. 2414. So called in distinction from the regular (double) berth-rest used on the berth-posts in the body of the car.

End-board (English). 68, figs. 348-51. American equivalent, *end-plank*. A plank in the end of a "goods wagon" or gondola-car.

End-brace. 35, figs. 229-66, etc. See *Body-brace*.

End brace-pocket. 35', figs. 229-66, etc. See *Pocket*.

End brace-rod. 34', figs. 229-66, etc. See *Brace-rod*.

End-carline. A carline (which see) at the end of a car-body. See also *End-plate*. *Platform-roof end-carline*.

End chute-plank. R, figs. 325-7. The planking of an inclined floor of a car which discharges its load longitudinally from the end toward the middle of a car, or vice-versa.

End compression-beam (passenger-car framing). Shown in fig. 429. A timber directly above the sills over the body-bolster against which the *compression-beam brace* and the *end-counterbrace* abut. The *compression-beam* proper is situated at the middle of the car directly under the window-sills. The end compression-beam is sometimes omitted.

End-counterbrace (passenger-car framing). Shown in fig. 429. More commonly, simply *counterbrace*. A brace in the side of a car-body, between its ends and the body-bolster. See *Counterbrace*.

End-door (box-cars). Fig. 4. A door frequently applied to afford means for the insertion of long pieces of freight or lumber that cannot be entered by the main side-doors.

End-doors (passenger-car). Figs. 1783-8.

End-door locks. Fig. 2644, etc. See *Locks*.

End-door sash-bolt. Figs. 4465-9, etc. See *Sash-bolt*.

End-door sash-lift. Fig. 4470. See *Sash-lift*.

End dump-car. Figs. 29, 32-3, 343-4a. A car with an end-door through which the contents of the car may be discharged by tipping the car or by having the floor inclined.

End face-plate. (Janney coupler). 147, fig. 2301. The wrought-iron plate on the nosing of the Janney platform.

End-frame (of a car-body). The frame which forms the end of a car-body. It includes the posts, braces, end-rail, end-girth, etc.

End-girth. 50, figs. 229-66, etc. A girth in the end of a box-car. An *end belt-rail*.

End-girth tie-rod. 51, figs. 229-66. A rod extending across the end of a freight-car body along the end-girth, from one corner-post to the other. An *end-belt-rail tie-rod*.

End grab-iron. See *Grab-iron*.

End half-longitudinal (English). 6, figs. 348-51, 501-6. American equivalent, *intermediate-sill*. A part of the *underframing* extending from the *cross-bearer* to the *headstock*.

End-hook (bell-cord). Figs. 2466-7. A hook sometimes used on the ends of passenger-cars, high up under the platform roof, for fastening the end of the bell-cord to.

End lamp-iron (English). 185, figs. 501-6. American equivalent, *tail-light holder*. A wrought-iron holder secured to the solebar or the end of the body in order to carry one of the colored signal or "tail" lamps, denoting the last vehicle of the train. See also *Side lamp-iron*.

End-lining hinged-sash (street-cars). 192, figs. 5654-67.

End-lining panel. 196, figs. 5654-67.

End-muntin (English). See *End-stanchion*.

End-panel. 1. Figs. 441, 446, and 46, fig. 5656. A panel at the end and on the outside of a passenger or street car below the window. In street-cars distinguished as *lower* and *upper*, both under the window. In passenger-cars

- distinguished as *end window-panel*, alongside of the window, and *end-panel*, below it.
2. (English). 127, fig. 504. A panel in the outside end of the body of a carriage, extending from the arch-rail to the *bottom end-piece*.
- End-piece** (wooden truck-frame). 17, figs. 4806-4966. A transverse timber or bar of iron by which the ends of the two wheel-pieces of a truck-frame are connected together. A *crooked end-piece* is one cut away on top to clear the draw-gear. The *inside end-piece* is the one nearest the center of the car, in distinction from the *outside end-piece*. They are frequently designated as the *front* and *back* end-piece, as in figs. 4833-40.
- End-piece corner-plate** (passenger-trucks). 130, figs. 4842-4966. See *Truck-frame corner-plate*.
- End-piece plate**. Figs. 5022-3. A top-plate for the end-piece of a passenger-truck.
- End-pillar** (English). 97, figs. 501-4. An upright post in the end of the body.
- End-plank** (of a gondola-car). They are often hinged to the car-floor so as to drop down upon it as in figs. 302-4, when they are called *drop-ends*.
- End-plate**. 48, figs. 229-66, 278-86, etc. A timber across the end and top of car-body and which is fastened to the two side-plates. It is usually made of the proper form to serve as an end-carline.
- End-plate strengthening-angle**. H, figs. 514-18. An angle iron bolted or lag-screwed to the top of the end-plate between the side-plates to strengthen the end-plate and the connection between the sides.
- End-Play**. 1. (Of an axle.) The movement, or space left for movement, endwise.
2. (Of a truck-bolster.) Usually called *lateral-motion*. See *Swing-bolster*.
- End-post**. See *Vestibule end-post*.
- End-post knee-iron** (street-cars). 28a, figs. 5654-67. See *Knee-iron*.
- End-rafter**. A term erroneously applied to the *end-carlines*, which see.
- End-rail**. 1. See *Wainscot end-rail* (lower and upper).
2. (English.) 106, figs. 501-4. A part of the body framing running horizontally across the end of the vehicle. See *Side-rail*, X, figs. 325-7.
- End roof-panel**. The panel above the door and below the clear-story.
- End scroll-iron** (English). 89, figs. 501-4. A wrought-iron support for the *spring-link adjusting-screw*. The upper face is attached to the under side of the *solebar*, and the lower part is bored horizontally for the adjusting-screw. It is placed near the end of the vehicle, and hence differs somewhat in pattern from the ordinary *scroll-iron*.
- End-seat panel** (street-car). An inside panel at the end of a longitudinal or side seat.
- End-sill**. 2, figs. 229-66, etc., 435-73, etc. The main outside transverse timber of a car-body into which all the floor-timbers are framed. In passenger-cars it comes directly under the door, the *platform* (which see) with its various parts, being a separate construction. A *spring end-sill*, which see, is sometimes added outside of the end-sill proper as a substitute for a draft-spring. In England the end-sill is termed the *head-stock*. In iron frame cars a wooden end-sill is commonly used, and bolted to an *end-sill channel-bar* with which the iron sills are connected, and which is the true end-sill.
- End-sill brackets** (of iron-frame cars). L-shaped angle-plates used to connect the iron sills and the end-sill channel-bar. In bridge-building such plates are termed *brackets*. When of triangular section they are termed *gussets*.
- End-sill channel-bar**. See above.
- End sill and plate tie-rod**. S, figs. 514-18. A tie-rod joining the end-sill, 2, with the end-plate, J, fig. 514.
- End-sill corner-plate**. Should read *End-piece corner-plate*.
- End-sill fitch-planks**. D, figs. 529-30. The planks or sticks of timber which are placed on the sides or between the fitch-plates, and are part of a *composite end-sill*.
- End-sill fitch-plates**. A, figs. 529-30. The iron or steel plates sandwiched between the wood members of a *composite end-sill*.
- End-sill protection-plates**. Figs. 1265-6.
- End-sill stiffening-angle**. B, figs. 514-18. Pullman *anti-telescoping device*. A $\frac{3}{4}$ x 3 x 4 angle iron riveted or bolted to the *end-sill stiffening-plate* and to the end-sill on the inside. The inner *body-truss rods* pass through it, the end-sill and the *truss-rod washer-plate*.
- End-sill stiffening-plate**. A, figs. 514-18. Pullman *anti-telescoping device*. A $\frac{3}{4}$ -inch plate, 20 inches wide in the middle by 12 inches at the ends, bolted on the under side of the end-sill and to the under side of the center, intermediate, and side sills.
- End-stanchion, or end-muntin** (English). 65, figs. 348-51. An upright bar at the end of a wagon, stiffening the end against shocks in switching.
- End-step** (street-car). 73-5, figs. 5654-5.
- End-stop** (journal-box). Figs. 5133-48 and 5165-6. A brass block inserted upon the inside of the lid to take up the end-thrust of the axle. In the *Raoul journal-box* the end-stop is a part of or attached to the box-lid. In the *Adams, Bissel, and C., B. & Q.* boxes the end-thrust is taken up by a *stop-wedge* which is held in place by lugs. End-stops were at one time in considerable favor and in quite general use; subsequently their use became very limited, but to-day they are in increasing favor. They have been in constant use on the six-wheel trucks of parlor and sleeping cars for many years. See *Stop-journal bearing* and *Stop-key journal bearing*.
- End-timber**. See *Platform end-timber* or *buffer-beam*, also *End-sill*.
- End truss-plank**. See *Truss-plank*.
- End ventilator**. An aperture for the admission or escape of air at the end of a car, usually placed over the windows. See also *Deck end-ventilator* and the *end-ventilator* for fruit-car.
- End-ventilator-opener**. See *Deck sash-opener*.
- End ventilator top-rail**. 173, fig. 557.
- End wainscot-panel**. See *Wainscot-panel*.
- End window-panel**. A panel at the end and on the outside of a passenger-car *alongside* of the window, in distinction from the *end-panel* proper, which is below the window.
- Engine and air-pump complete** (Westinghouse brake). Figs. 1689, 1691-2. A machine attached to a locomotive for compressing air. It consists of a *steam* and an *air-cylinder*, the pistons in which are connected to the same piston-rod, so that the *air-piston* is worked directly by the *steam-piston*. Suitable valves are provided for admitting and exhausting the steam and air to and from the cylinders. See *Reversing-valve*, etc.
- Engineer's brake and equalizing discharge-valve** (Westinghouse brake). Figs. 1710-13. The valve now used instead of the old three-way cock, figs. 1708-9, for applying and releasing the brakes. A valve device located in the cab of the locomotive for applying and releasing the air-brakes. It is operated by the engineer through the medium of a projecting handle or lever. In the *release position* of the handle, the air from the main reservoir has direct access, through a large port, to the train-pipe. In the *running position* the air from the main reservoir has access to the train-pipe only through the feed-valve attachment which operates to limit the pressure in the train-pipe to 70 lbs. when it is 90 lbs. in the storage reservoir. In the position for *service application* of the brakes the air pressure is partially released from the chamber above a piston which is then forced upward by the train-pipe pressure below it and opens a

valve to the atmosphere through which the train-pipe air is discharged at such a rate that the emergency action of the triple-valves on the cars cannot take place. Any degree of reduction of train-pipe pressure may be effected in this way for graduated applications of the brakes. In the position for the *emergency application* of the brakes, a large direct port from the train-pipe to the atmosphere is opened, which causes the instantaneous application of the brakes throughout the train.

Engine-lamp. Fig. 3318.

English first-class carriage. Figs. 501-4. See *Carriage and First-class carriage*.

English wagon. Figs. 343-51. See *Wagon and Van*.

English wheels. Figs. 5320 and 5347. See *Steel-tired-wheel. Mansell wheel. Teakwood-center wheel*.

Equal-bar nest-spring. A nest-spring of any number of coils, each bar of which is, or is supposed to be, of the same total length, so that the resistance of each coil may be more nearly equal. The name means little. See *Spiral-spring*.

Equalizer. 1. A short term for an *equalizing bar*, which see.

2. (Janney coupler). 51, figs. 2442-2; 134, figs. 2301, etc. The bar connecting the two buffers and having a bearing against the *center-buffer spring*.

3. (Pullman vestibule). 27, figs. 2437-45. A bar in the hood of a platform which equalizes the pressure of the two upper face-plate springs and keeps the opposing face-plates together in contact, so as to maintain frictional contact and exclude dust and smoke.

Equalizer-block. See *Brake-equalizer block*.

Equalizer connecting-chain. 26, figs. 2437-45 (Pullman vestibules). Three links of a chain connecting the upper ends of the *vertical equalizing-levers* with the ends of the *horizontal equalizing-lever*.

Equalizer-guides (Janney-Miller coupler). Cast-iron chafing-plates bolted to the main knees of the Janney platform, above and below the equalizer.

Equalizer-spring. 79, figs. 4942-66, and figs. 5223-8. A spring which rests on an *equalizing-bar* and carries the weight of a car. Single or two-group spiral springs are generally used for this purpose. Rubber and volute springs are out of use.

Equalizer-spring cap. 72, figs. 4942-66. A casting on top of the spring, which bears against the under side of the wheel-piece and holds the spring in its place.

Equalizer-spring seat. 73, figs. 4942-66. A casting which sets on an *equalizing-bar* and on which the spring rests. See *Spring-plate*.

Equalizer-strap. See *Brake-equalizer strap*.

Equalizing-bar (passenger-car trucks). 71, figs. 4942-66; figs. 4889-90, 5064-6, etc. Commonly abbreviated into *equalizer*. A wrought-iron bar which bears on top of the journal-boxes and extends longitudinally from one to the other. *Equalizer-springs* rest on it between the two boxes. It is used to transfer part of the weight on one wheel to the other, and thus equalize it on both; hence its name. Equalizer-bars are sometimes used to connect the ends of semi-elliptic springs, as in the four-wheel caboose-car shown in fig. 51. The use of *equalizing-bar* on such caboose-cars has been abandoned generally, and the style shown in fig. 50 adopted.

Equalizing-bar pedestal (four-wheel caboose-cars). Fig. 51. A casting serving to give a fulcrum to the center of an *equalizing-lever*.

Equalizing-bar seat. The surface on top of a journal-box on which an equalizer rests.

Equalizing brake-lever. A *floating-lever*, which see. The *center brake-lever* is also, with little propriety, so called.

Equalizing-lever. An *equalizing-bar*, which see. A *floating-lever* is also called an *equalizing-lever*.

Equalizing reservoir. 10e, figs. 1699-1707, and fig. 1714. A reservoir placed on the side of the locomotive underneath the cab, the office of which is to increase the vol-

ume of the chamber above the piston in the *engineer's-brake and equalizing discharge-valve*.

Equalizing-valve (Westinghouse brake). A valve for use on long trains to equalize the pressure in the brake-pipe and prevent the inequality of pressure in the front portion of the pipe during the brief period in which the brakes are being applied by release of air from the brake-pipes, from tending to first apply and then immediately release the brakes on the forward cars, owing to the rush of air from the rear portion of the train.

"Erie" caboose-stove and details. Figs. 3061-72ab. A stove in use on the N. Y., L. E. & W. R. R. on caboose-cars.

Escutcheon. 1. Figs. 2621-7, etc. A plate or guard for a key-hole of a lock. Similar plates for the holes through which door-knob spindles pass are also called *escutcheons*, but more commonly *rose* or *rosette*. See *Seat-lock escutcheon*. An *escutcheon-plate* is often attached to an *escutcheon* to cover the key-hole.

2. (Yale lock.) A revolving post provided with holes to carry the pins which act as tumblers. When the key with corrugated edge is inserted, each of these tumblers is raised so that the joint comes exactly at the edge of the *escutcheon*, thus permitting revolution.

3. (Padlock.) Fig. 2765. More properly an *escutcheon-plate*. See above.

Escutcheon-plate. See *Escutcheon*.

Eubank car-door. A patent door said to be spark and storm proof. The door slides upon an overhead track, and is divided horizontally so that it may be pushed past the cleats between which it closes. To bend the door at the hinged division, an eccentric rod and lever is attached.

Eureka brake-slack adjuster. Figs. 1776-7. See *Brake-slack adjusters*.

"Eureka" spiral seat-spring. Fig. 4013. See *Seat-spring*.

Excelsior car-roof. Figs. 2380-88. See *Car-roof*.

Excelsior galvanized car-roof. Figs. 2385-91. See *Car-roof*.

Excelsior steam-trap, sediment well, gravity relief trap and special blow-off valve. (Gold's car-heating.) Fig. 3007. See *Thermostatic steam-trap, Sediment-well, Gravity relief-trap and Blow-off valve*.

Excursion-car. 1. Fig. 151. A light, open-sided car, with reversible seats running entirely across it, largely used for short-distance summer travel, to resorts near large cities.

2. Figs. 153-4. A car for excursionists or troops hastily built or converted, and whose service as an excursion-car is limited to the occasion for which it was constructed or rebuilt. Under such a head may be classed cars shown in figs. 153-4 and 497-500, which are ultimately and chiefly intended for freight service.

3. Figs. 119, 180-1, 193-202. A special form of *palace-car* kept for rent at fixed rates per day to parties or individuals. They are similar in arrangement to the ordinary forms of officers' or other private cars, except that they usually have a greater number of berths, commonly sixteen, and two or more staterooms in addition. They are provided with kitchen and other conveniences like a *hotel-car*, and are kept for lease by the leading sleeping-car companies. They vary in length from 59 to 69 feet in car-body.

Exhaust-pipe (Westinghouse pump). 7, figs. 1699-1707; 57, fig. 1689. A pipe through which the exhaust steam is conveyed from the steam-cylinder to the smokestack.

Exhaust-pipe (Eames ejector). 53, figs. 1663-4.

Exhaust-pipe union (Westinghouse air-pump, etc.). 15, fig. 1689.

Exhaust ventilator (for closet-hoppers). Figs. 3841-2. See *Bell's exhaust hopper-ventilator*.

Expander (Westinghouse brake). See *Piston-packing expander*.

Expanding collar (for lamp). Fig. 3405. One used to enable a larger-sized burner to be used. See *Collar*.

Expansion-drum (Baker-heater). Figs. 2893, 2902-3. A *circulating-drum*, which see.

Express car. Figs. 87, 139-41, 168-70, 267-73, 570-98. A car for carrying light packages of freight for express companies on passenger trains. Also see *Combination baggage-car*, figs. 599-604.

The express business was originated in 1839 by William F. Harnden, who traveled for some time as a messenger between New York and Boston; but it was not for a long time thereafter that it grew to sufficient dimensions to require separate cars. Alvin Adams, founder of the Adams Express Company, began business in 1840. At present complete trains of express-cars are occasionally required.

Express hand-car. A hand-car with large wheels to run at a high speed. Several different designs exist not called by this name, but accomplishing, or seeking to accomplish, the same end. See *Hand-car*.

Extension-reach (logging-cars). Fig. 36. The *reach* is a long bar connecting the two trucks. The extension-reach is adjustable.

Extension-reach end (logging-cars). A strap for the end of the extension-reach.

External cylinder-gage. A steel ring with a cylindrical hole which is very accurately made of a precise size, and used as a standard of measurement for the diameters of solid cylindrical objects.

External screw-gage. A steel ring with a very accurate screw-thread in the inside for testing screw-threads. See *Internal screw-gage*.

Eye. "A small hole or aperture."—*Webster*.

See <i>Body check-chain eye</i> .	<i>Lamp-case eye</i> .
<i>Berth-brace eye</i> .	<i>Brake-beam adjusting-hanger eye</i> .
<i>Bull's-eye</i> .	<i>Switching eye</i> .
<i>Chain-check eye</i> .	<i>Truck check-chain eye</i> .
<i>Coupling-pin-chain eye</i> .	

Eye-bolt. 1. "A bolt having an eye or loop at one end for the reception of a ring, hook, or rope, as may be required."—*Knight*. See *Bolt*; also

<i>Brake-beam eye-bolt</i> .	<i>Lock eye-bolt</i> .
<i>Brake safety-chain eye-bolt</i> .	<i>Lock-chain eye-bolt</i> .

2. For *Miller hook* (Janney-Miller coupler). The part by which the swivel connected to the uncoupling lever is secured to the Miller hook. It is a $\frac{3}{4}$ -inch bolt.

3. For *side-spring* (Janney-Miller coupler). The eye-bolt by which the side-spring stirrup is secured to the horn. It is a $\frac{3}{4}$ -inch bolt.

Eye-bolt link-hanger. A special form of *swing-hanger*, which see, having a very short link attached to an eye-bolt passing through the transoms.

Eye-head coupling-pin. So called in distinction from a *solid-head* or *bent-head coupling-pin*.

Eyelet. 1. Figs. 2852-4. "A short metallic tube, the ends of which are flanged over against the object through which it passes. Used as a bushing or reinforce for holes."—*Knight*. In metallic eyelets of the usual form, the two halves which when compressed together form the eyelet are known as *grommets*. See *Carpet-eyelets*.

2. (Window-shade.) 3, figs. 4560-1, 4552-4. A slot in the window-shade leather to fit over the sash-lift, to hold the shade fast.

Eyelet-nail. Fig. 2855. A wire nail with turned knob, for use with carpet-eyelets.

Eyelet-shackle car-seal. Figs. 3882, 3889. See *Car-seal*.

F

Face (of rim of car-wheel). The vertical surface of the outside of the rim.

Face-board circle (street-cars). 190, figs. 5654-67.

Face-plate. 1. A metal plate by which any object is covered, so as to protect it from wear or abrasion. A *journal-box lid* is sometimes called a face-plate.

See *Berth-latch face-plate*. *Drawbar face-plate*.
Buffer-block face-plate. *End face-plate*.

2. (Steel-tired wheels.) Figs. 5255-6, 5308-11. The plates connecting the tire and hub, and bolted to each. They are distinguished as *front* and *back face-plates*.

Face-plate. See *Vestibules*.

Face-plate buffer. 8, figs. 2425-46. A *buffer-plate* to which a *vestibule face-plate* is attached.

Face-plate buffing-stem (Pullman vestibule). See *Face-plate piston*.

Face-plate piston (vestibules). 24, figs. 2425-45. A face-plate buffing-stem corresponding to *side buffer-stem*, beneath the platform floor. The end is contained by a *Face-plate piston-guide*, 29.

Face-plate restraining-chain (Gould vestibule). 26, figs. 2431-6. A chain the two ends of which are fastened to the back face-plate, as in fig. 2432, and the loop working in a sheave on the front or diaphragm face-plate. It limits the longitudinal and lateral motion of the *front face-plate*.

Facing. "A covering in front for ornament."—*Webster*. See *Deck-sill facing*.

Faggoted axle. See *Axle*. *Car-axle*.

Fall (hoisting-tackle). That part of the rope to which power is applied.

Fall and tackle. Another name for *block and tackle*, which see.

Falling-door, or flap-door (English). 70, figs. 348-51. In a *gondola-car* (*open wagon*) a door opening downward and outward, the hinges being on the lower side. It is generally arranged as shown, but is also made to open up to the top of the side, or to extend the whole length and depth of the side.

Falling-door latch (English). 79, figs. 348-51. A latch which automatically secures the falling door when elevated into a closed position.

Fall-under, or turn-under (English). 116, fig. 503. The distance which the bottom of the body curves in from a vertical line let fall from the sides or ends.

Fare-box street car. A street-car in which the fare is deposited by the passengers in a box under the observation of the driver. They usually have an inclosed platform in front, and are entered only from the rear. They are turned around at the end of each trip, either on a turn-table or (rarely) on their own truck.

Fare-register (street-cars). 206, figs. 5654, etc. A mechanism with a clock face and index or with a numbering dial which shows the number of fares collected and registered. For every fare collected the conductor is expected to record it by pulling a cord or turning a rod connected with the register. The register is attached to a *fare-register block* which is fastened to the car frame.

Fare-wicket (street-cars). An opening in the door for collecting fare or making change.

Fare-wicket door-case. See above.

Fascia-board. See *Eaves fascia-board*. *Inside-cornice fascia-board*. *Inside-cornice sub-fascia-board*.

Fascia-molding (English). See *Wrought-molding*.

Fast berth-hinge. Fig. 4189. See *Berth-hinge*.

Fastener.

See <i>Berth safety-rope fastener</i> .	<i>Sash-fastener</i> .
<i>Lamp-fastener</i> .	<i>Tire-fastener</i> .
	<i>Window-fastener</i> .

Fast-joint butt-hinge. Figs. 2601, 2606-7. See *Hinge*. So called in distinction from a *loose-joint butt-hinge* or *loose-pin butt-hinge*.

Fast lamp-globe. One which cannot be detached. Also called a *plastered globe*. See *Lamp-globe*.

Faucet. Figs. 3485-94. A synonymous term with *cock*, which see for fuller definition.

Faucet-alcove. Figs. 3552-3. A *water-alcove*, which see.
Feed-door (Baker-heater). Figs. 2873, etc. A door for closing the aperture giving access to the fire-pot or (in base-burners) magazine. See also *Fire-door*.

Feeder-cup and collar (for lamps). Figs. 3394-5.

Feeder-screw and hoop (for lamps). Figs. 3409-10.

Feed-tube (student-lamp). **K**, fig. 3399. The tube connecting the reservoir with the burner. The standard by which the entire lamp is supported passes through it.

Feed-tube collar (student-lamp). **G**, fig. 3399.

Feed-valve. 1. (Westinghouse air-brake.) Fig. 1711. An auxiliary-valve attached to the *engineer's brake and equalizing discharge-valve*, and consisting of a *feed-valve body*, **62**, *cap-nut*, **65**, a *piston*, **74**, *piston-rod*, **66**, a *spring*, **64**, *piston-nut*, **73**, a *stud*, **59**, a *case-gasket*, **56**, a *friction-ring*, **67**, and other essential parts.

2. (Of engine signal-valve, Westinghouse train-signal apparatus.) **6**, fig. 690. The valve regulating the supply of air from the main reservoir.

Felt-edge (for car-seats). A device for building up the edges of car-seat cushions. It is simply a roll of felt stitched in such a manner as to fit over a cleat; and when tacked down it forms an even elastic face to the cushion.

Female center-plate. The body and truck center-plates are sometimes called male and female plates. See *Center-plate*.

Female-gage. An *external gage*, which see.

Fender. See *Door-fender* (street-cars.)

Fender-board. A board at the end of passenger-car steps to prevent mud and dirt from being thrown on them by the wheels. More commonly, *string-board*. The *splash-board*, if used, goes on the back side of the steps.

Fender-guard. **42**, figs. 5654-67. A *guard-fender*. See below.

Fender-rail (street-car bodies). **41**, figs. 5654-67. A longitudinal exterior rail, between the belt-rail and the sill, and to which an iron strip called a *fender-guard* is attached to protect the panels from contact with other vehicles.

Ferry push-car. A very long platform-car used for pushing or pulling other cars on or off a ferry-boat when the latter is approached by an incline too steep for locomotives, so that the latter can push or pull the cars without running on the incline.

Fiber-packing. See *Elastic-fiber journal-packing*. *Patent waste*.

Fillet. A small light molding, more generally termed *beads*. See *Molding*.

Filling-funnel (Baker-heater). Fig. 2914. A funnel attached to the combination cock for filling the circulating-drum with brine.

Filling-piece. **175-6**, fig. 557; **121**, figs. 551, 556, 560. Any piece of timber which has no other structural purpose than to close a gap.

Filling-board. **208**, **209**, fig., 560.

Filling-valve (Pintsch system). **65**, fig. 3162. This valve is a soft metallic seated valve of peculiar construction. Is handled with key No. 45 (fig. 3214) and is a *left-handed* valve. It is placed on each side of a car, bolted to iron bracket, **118-A**, fig. 3163, by bolts **171**, fig. 3188. The pipe connection ($\frac{1}{4}$ in.) is made to connection piece, **9**, fig. 3182, which is slipped through the bracket **118-A** from the outside and screwed to the pipe. The filling valve is then bolted back against this flange connection piece, a lead and rubber gasket forming the tight joint.

The valve has a sheet-iron cover **89**, fig. 3161, secured to it by four screws. It is shown at **F**, fig. 3160; fig. 3162.

Finger-guard. (Brake-beams.) Figs. 1630-2.

Finished upper-seat back-rail (Street-cars). **110**, fig. 5656. The topmost rail or molding of a longitudinal seat-back.

Finishing varnish (painting). An elastic (oily) varnish applied in two coats. The first is allowed at least 24 hours to dry. The second and fuller coat of the same varnish is then applied and allowed 24 hours to dry. A

first-class job can be turned out in 10 days. Additional time between coats will give additional safety. See *Painting*.

Fire-box or fire-pot (Baker-heater). Figs. 2888, 2909, 2926, etc. The inside cast-iron cylinder which contains the fire. It is cast in one piece and contains the coil. Also called *fire-chamber*, *fire-box*, *furnace*, and sometimes *cylinder*.

Fire-grate, and fire-grate support. See *Grate and grate support*.

Fire-extinguisher. Fig. 3704. See *Babcock fire-extinguisher*.

Fire-proof heaters (Baker's). 1. Single coil. Figs. 2865-2884. A Baker-heater having a single coil, 30 feet in length, fig. 2874 or a double coil, fig. 2894, in a flexible steel, jointless fire-proof safe, with no apertures large enough to permit the escape of live coals. This inner fire-pot or safe is enclosed in a flexible steel *outside casing*, with asbestos sheets between the safe and casing, and between the *ash-pit bottom* and sheet-iron bottom; a *safety-plate* covers the feed chute at the top, and a cinder-proof door effectually closes the ash-pit at the bottom. The *smoke-pipe* and *smoke-flue base* may be destroyed and leave the fire-pot practically fire-proof.

2. Two-coil. Figs. 2885-2900.

Fire-regulator and pressure-indicator. Fig. 2865-8. The device is attached to the *hot-water circulating-pipes* at a point a little above the coils, and is somewhat after the old "ball-and-lever safety valve," the ball or weight in this case being the draft-door. The *fire-regulator bowl* consists of two concave plates bolted together, with a corrugated-steel diaphragm and two copper duplicates, top and bottom, between (for preservation). On this set of diaphragms rests a piston connected with a lever, on one end of which hangs the counter-draft damper in the base of the smoke-flue. On the front end of this lever is the spiral adjusting spring, and the figures denoting the pressure within the heater. The "adjusting spring" is to be hooked into the hole at the figures denoting the pressure and consequent *temperature* desired.

First-class car. Figs. 89-96, 155-9, 163-4, 189, 419-467, 531-67. The ordinary American day coach used by the great bulk of short trip passengers. So called to distinguish it, on the one hand, from those of an inferior grade, as *emigrant* and (rarely) *second-class* cars, and on the other hand from *sleeping* and *parlor-cars* (which see), and in which an extra charge, in addition to the ordinary fare, is made, and which are the true American first-class cars.

First-class carriage (English). Figs. 501-4. Nearest American equivalent, *parlor* or *drawing-room car*. A coach for passengers paying the highest rate of fare. It is divided into four or more compartments, each about 7 feet cube, and seating six or eight passengers.

Fish van (English). A covered vehicle adapted to run on passenger trains, and fitted to carry fresh fish in crates or boxes. When without a roof it is termed a *fish truck*.

Fittings. Figs. 2454-4575. *Furnishings*, which see.

Five-group spiral-spring. Figs. 5195-6. See *Spiral-spring*.

Fixed brake-lever. **7**, figs. 1535-6. More commonly, *dead-lever*. A brake-lever, the upper end of which is fastened to a brake-lever stop or dead-lever guide.

Fixed or stationary freight-car lock. Figs. 2736-41. A lock which is attached to the side of a car. The bolt or hasp is fastened to the door.

Fixed hanger (bell-cord). Fig. 2514. See *Bell-cord hanger*.

Fixed ratchet (in Morgan's deck-sash pivot). Figs. 4385-8. The piece attached to the side of the window-frame with which the sash-ratchet engages, the latter being pressed against it by a spring.

Flag (for train-signals). The standard size of flags adopted by the American Railway Association is 16 x 16

- inches, and the colors indicate their purpose as follows: *Red* signifies *danger* and is a signal to *stop*; *green* signifies *caution* and is a signal to go *slowly*; *white* signifies *safety* and is a signal to go *on*; *blue* denotes that car inspectors are at work under or about the train or car, and that it cannot be moved or coupled to until the blue signal is removed by the car inspectors. In the nighttime lanterns with colored glass globes are used instead of flags and the colored lights have the same meaning as the colored flags.
- Flag-holder** (for corner-post of passenger-car). Figs. 3343-4. A cast or malleable iron receptacle for a signal-flag staff. It has a lug cast on it which engages into a *flag-holder plate* attached to the corner-post.
- Flag-holder plate.** See above.
- Flange.** 1. (Of bell-cord guides, etc., etc.) Figs. 2479 2481, 2503, 2522, etc. A projecting rim for attaching the part to any surface by wood screws.
2. (Of a car-wheel.) Fig. 5424. A projecting edge or rim on the periphery for keeping it on the rail. The inside edge of the flange which connects with the tread of the wheel is termed the *throat*, and the extreme outer point the *toe* of the flange. Worn flanges having flat vertical surfaces extending more than 1 inch from tread of wheel, or 1 inch thick or less, are a cause for rejection under the rules for interchange of traffic. See *Wheels*. The standard distances fixed by the Master Car-Builders' Association, from outside of flange to inside of tread in surface, is 4 feet 5½ ins., as shown in fig. 5421, with ¼-inch variation either way. See *Interchange Rules*. See *Flange gage*. See also *Wheel-center flange* in figs. 5266 and 5269.
- Flange brake-shoe.** Figs. 1644-5, etc. See *Ross brake-shoe*.
- Flange-collar** (of a passenger-car door lock). C, fig. 2630.
- Flange-fittings** (Pintsch system). Figs. 3166, 3169-78. Special fittings required for the Pintsch system are all flanged and made of brass, the flanges held together by screws. The joints are made tight by the use of special lead and rubber washers.
- Flange-gage, or distance-gage.** Fig. 5488. A gage for determining the correctness of the distance between inside and outside of flanges. The dimensions shown in the engravings are those adopted by the M. C. B. Association.
- Flanger.** See *Snow-plunger*.
- Flap-door** (English). See *Falling-door*.
- Flashing.** Figs. 2390-1. Plumbing. A lap-joint used in sheet-metal roofing, where the edges of the sheets meet on a projecting ridge. A strip of lead leading the drip of a wall into a gutter.—*Knighl*. Hence extended to mean any strip of sheet-metal of an L-section used to make a water-tight joint.
- Flat-bar spiral-spring.** Fig. 5244. One made by winding a flat bar flatwise, in distinction from *edge-rolled*, which is a similar bar wound edgewise, fig. 5252.
- Flat-car.** Figs. 16-19 and 287-97. A car, the body of which consists simply of a platform, which is not inclosed on the sides or top. If sides are added it becomes a *gondola-car*. See *Car* and *Freight-car*.
- Flat door-bolt.** Fig. 2547. See *Door-bolt*.
- Flat or oval coupling-pin.** Figs. 2286-7. See *Coupling-pin*.
- Fletcher journal-box lid.** Figs. 5152-3. A flat plate held down by a spring at the pivot. The drawings given are somewhat in error. There is a sleeve-washer which fits in over the pivot-bolt to afford a bearing for the nut, and no pin is used to hold the latter in place, as represented. Figs. 5167, 5169, 5172-5 are modified types of the *Fletcher-lid*.
- Flexible frame** (logging and other cheap cars). A frame so constructed that the natural spring of the wood may serve in part as an equivalent for metallic springs, the latter being dispensed with. Many narrow-gage freight cars use *spring end-sills*, which see, in a similar manner.
- Flexible-top seat-cushions.** Figs. 3929-38, etc. A seat-cushion, the top of which is in detached parts so that one part can yield without carrying down the other.
- Fitch-plates.** Figs. 899, 1428-30. An iron or steel plate sandwiched between pieces of wood and bolted together to give the member which they comprise greater strength. Also called *sandwich-plates*.
- Floating connecting-rod.** 1. (Hodge brake). 8, fig. 1463. A horizontal rod which connects the two floating-levers together.
2. (Westinghouse brake). 8, figs. 1693-4. A rod which connects a cylinder-lever with a floating-lever.
- Floating-lever.** 1. (Hodge brake). 7, fig. 1463; 12, figs. 1693-8. One of two horizontal brake-levers which are used under the center of a car-body. They are each connected at one end with one of the brake-levers on the truck, and at the other end with the brake-windlass. The centers of the floating-levers are connected together by a rod called a *floating connecting-rod*.
2. (Westinghouse freight-brake.) 7, figs. 1695-8. A lever, to the middle of which the *push-rod* is attached, each end being connected directly to the *live-lever* of each truck.
- Floating-lever bracket.** Figs. 1467-70. A bracket bolted to the underframe of a car to carry the floating lever of the Hodge brake-gear.
- Floating-lever guide.** 15a, figs. 1693-8.
- Floating-lever connecting-rod.** (Westinghouse freight brake-gear). 14, figs. 1695-8. More properly a *cylinder-lever tie-rod*, which see.
- Floor.** 1. "That part of a building or room on which we walk; the bottom or lower part consisting, in modern houses, of boards, planks, or pavement.
2. "A platform of boards or planks laid on timbers as in a bridge or car; any similar platform."—*Webster*.
3. 27, figs. 229-473, etc. The boards which cover the sills of a car. In passenger-cars the floor consists of two and sometimes three courses of boards, called respectively the *flooring*, *intermediate floor* and *deafening ceiling*, the latter being on the under side of the sills. An intermediate or *upper floor*, 28, more commonly called the *double-deck*, is used in stock cars for carrying sheep and hogs. Hopper-bottom cars have an *inclined floor* subdivided into inclined *end-floor* and *side-floor* when both are used, which is not usual. This floor is infrequently made of iron plates called *hopper-plates*.
- Floor-beam.** A *sill*, which see.
- Floor-frame.** The main frame of a car-body underneath the floor, including the sills, body-bolsters, needle-beams, etc. The *under-frame*.
- Floor-furnishings.** Figs. 2852-64.
- Flooring.** Tongued and grooved (which see) boards of which a passenger-car floor is made. The floor of freight cars is commonly two-inch *planking*.
- Floor-joist.** A *floor-timber*.
- Floor-mat.** Figs. 2856-7. A texture or structure of hemp, cocoa-fiber, rattan, india-rubber, wood, or other material laid on the floor of a car for passengers to clean their boots and shoes on. Mats are placed on the floors of street-cars to take up the dirt and dust. See *Cocoa-fiber*. *Wood floor-mat*. *Rubber floor-mat*. The latter is either *perforated* or *corrugated*.
- Floor-pipe** (for closet-hoppers.) Figs. 3838-9. A pipe passing through the floor of the car only, with which the hopper proper is connected.
- Floor-stop.** 1. (For door-holder.) Figs. 2803-4, 2809-10. A catch for a door-holder attached to the floor, in distinction from a *partition-stop* attached to the wall or partition. See *Door-holder*.
2. (Grain-door.) g, fig. 1869.
- Floor-strip.** 20, fig. 5656. The strips that make the grated floor frames of a street-car.
- Floor-timbers.** 1 3, 4, figs. 229-473, etc. The main timbers in the frame of a car-body underneath the floor, and on

which the latter rests. They are chiefly the *sills* (side, center, and intermediate) and the *end-sills*. They are a part of the underframe. See also *Diagonal floor-timber*. *Inclined floor-timber*. *Transverse floor-timber*.

Floor-timber braces. 7, figs. 436, 448, etc. Diagonal timbers let into the sills under the floor to stiffen the floor-frame laterally.

Floor-timber distance-block. A short transverse piece of timber placed between adjoining floor-timbers and sills to stiffen them, the whole being fastened together with bolts in connection with a *cross-frame tie-bolt*. In iron frame cars, *tie-plates* are riveted across the top of the sills to subserve the same purpose. They are little used to-day. See *Bridging*.

Flush-bolt. Figs. 2544-5. A bolt attached to a slide which is let into a door, sash, or window, so as to be flush with its surface. A *spring flush-bolt* is commonly called a *cupboard-catch*. Figs. 2548-9.

Flush-bolt keeper. Figs. 2549. A plate which is attached to a door, sash, or window frame, and has a suitable hole in which a flush-bolt engages. When for spring-bolts, as in the engraving, they are also called *strike-plates*.

Flush-catch. Figs. 2548-9.

Flush-handle. Figs. 2569, 2574, 2576-8, etc. A handle for a lock or latch which is placed in a recess, as of a door, sash, or berth, and which does not project beyond the surface of the object to which it is attached.

Flush sash-lift. Fig. 4512. A metal plate with a recess, to take hold of, which is let into a sash so as to be flush with its surface.

Fluted weather-boards. 52S, figs. 283-6. Sheathing that has one or several grooves cut out, longitudinally, and for the whole length of the piece. The object of such grooving is twofold: 1. To make the sheathing much lighter without weakening it in the same ratio; 2. In figs. 383-6, to secure a free circulation of air behind the sheathing. Fig. 285 shows the weather-boards in detail.

Fogg's upper-berth-hinge. Figs. 4186-7. See *Berth-hinge*.

Folding arm-rest, or elbow-rest (English). 198, figs. 501-4. A wooden support for the elbow, upholstered on both the upper and lower sides, and fitted with a spring-hinge, so that it can be turned up to lie flat against the back of the seat, in order to allow a passenger to lie down at full length on the seat.

Folding-curtain rod-bracket. Fig. 4194. See *Curtain-rod-bracket*.

Folding-laboratory. Fig. 3508-9. A device for the staterooms of sleeping, private, and business cars, which can be folded out of the way and out of sight.

Folding-platform tail-gate. Figs. 3805-6. A gate for the end door or face-plate door of a vestibule.

Folding-side gondola-car. A gondola-car, the sides of which are attached with hinges, so that they can be folded up or down. Rarely met with to-day, but folding-end gondolas are quite common.

Folding wash-stand (Pullman). Figs. 3529-32. A lavatory for the staterooms of compartment sleepers.

Follower. 1. A very common abbreviation for a *follower-plate*, which see.
2. (Janney and Janney-Miller coupler.) A drawbar follower-plate.
3. (Pistons, which see.) A common abbreviation for the *follower-plate*, which holds on the packing of a piston.

Follower-bolt. A *piston follower-bolt*. See *Piston*.

Follower-guide (Janney-Miller coupler). A *drawbar guide*, which see.

Follower-lug. A *drawbar stop*, which see.

Follower-plate. See *Buffer-spring follower-plate*. *Drawbar follower-plate*. *Piston follower-plate*. The word "plate" is frequently omitted from these names.

Foot-board. 1. (Freight-cars). See *Brake-step*.

2. (English.) (*Upper and lower*.) 172, figs. 501-4. American equivalent (street-cars), *longitudinal step*. Two continuous steps running along the sides of a *carriage* or *brake van*, the *upper* a short distance below the doors, and slightly above the level of highest station platform; the *lower* about 18 ins. from the rail level. They form steps and prevent any person falling between the train and the platform. American *excursion cars*, which see, fig. 151, have a single foot-board, often so called.

Foot-board bracket. See *Brake-step bracket*.

Foot-plate (Janney coupler). 169, fig. 2301. A cast-iron wearing-plate on the upper side of the passenger-platform end-rail. In platforms taking vestibules a *sliding foot-plate* is attached to the buffer-plate and works or slides back and forth in a *foot-plate housing*.

Foot-plate housing. 139, figs. 2301, etc. See above.

Foot-rail. 23, figs. 3917-23, 3976-83. A horizontal wooden bar underneath a car-seat for the passengers who occupy the next seat, to rest their feet on. These fixed foot-rails are often called *foot-rests*, but such use is confusing, since the term *foot-rest*, which see, is applied to many forms of adjustable foot-rests. 23, figs. 3971-3. See *Side foot-rest*.

Foot-rest. 1. 23, figs. 3971-3, and 29, figs. 3924, 3974-5. Any *movable* support for the feet of passengers, especially two horizontal wooden bars underneath a car-seat, and attached to two iron rockers called *foot-rest carriers*, pivoted in the center so that it can be adjusted to a comfortable position for the passenger occupying the next seat, or moved out of the way if desired. Another style is an *adjustable foot-rest*, figs. 3974-5, sliding in a grooved channel. A portable stuffed carpet foot-rest is usually termed an *ottoman* or *hassock*, fig. 3706.

2. (Hartley and Hitchcock chairs.) 2, figs. 3998-9. An extension of the chair, consisting of two leaves, front and back, carried within the *foot-rest frame* and supported from below by a *foot-rest carrier*. In the former, it is in the form of the arc of a circle, and its position is regulated by the *adjusting-lever*, 15. Some of the chairs also carry a *back foot-rest*, 5 and 6, for the benefit of the occupant of the chair in the rear.

3. (Scarritt-Forney seat.) An adjustable foot-rest or rail; consists of two *foot-rest arms* hinged to the *seat-stand* and carrying a *foot-rest stop* or *rail* which may be adjusted to any height, that the height of seat will permit, by a *foot-rest pawl* that engages in a *foot-rest ratchet* screwed to the floor.

Foot-rest carriers. See above.

Foot-rest rod-bracket. Figs. 3616-17.

Foreign car. Any car not belonging to the particular railroad on which it is running, including *line cars*, which see. By the established rules for interchange of traffic all such cars are, or are supposed to be, inspected before entering on the lines of a foreign corporation, and "if an accepted foreign car is injured upon a road it shall be repaired by and at the expense of the company in possession thereof as promptly as it repairs its own cars." The cost thereof is sometimes charged to the owner of the car and sometimes not, according to an elaborate system of rules adopted by the M. C. B. Association, revised annually. See *Interchange Rules*.

Forney seats. Figs. 3968-76. See *Scarritt-Forney seats*.

Fount. See *Lamp-fount*.

Fountain car-washer. Fig. 3702. A car-washer which has a stream of water passing through the brush at the will of the operator.

Four-arm lamps. Figs. 3240, 3273, 3336, etc. See *Pintsch lamps*. *Frost lamps*, and *Chandeliers*.

Four-place boudoir (Mann boudoir-car). Fig. 2418.

Four-way cock (Westinghouse brake). 13, figs. 1708-9. A tapered conical spindle, with two passages in it which form a faucet for opening and closing communication between the brake cylinder, reservoir, and brake pipe.

Four-wheel car. The original type of railway vehicle, still almost universal in England and on the Continent. There are a few four-wheeled coal-cars in existence still in this country, but a four-wheeled box-car is met but rarely and then only on the road to which it belongs. No new four-wheeled cars are being built for interchange of traffic; the tendency being to make short heavy trains in preference to long trains of equal weight. The truck of an ordinary American eight-wheel car is simply a four-wheel car carrying half the weight of the car-body as a dead load upon it.

Four-wheel trucks. Figs. 4576-4956.

Fox pressed-steel frame (for street-car trucks). Fig. 5669.

Fox solid-pressed-steel car-truck. Figs. 4578, 4753-85. A truck, the frame of which is wrought and hydraulic-forged of plate steel consisting of few pieces which are all riveted together. It is a pedestal truck with journal-

system of screw-threads, which see, is often called the Franklin Institute system because the former was first proposed in a report to, and was recommended by, the Franklin Institute.

Free air-space (refrigerator-car insulation). An air space which has free communication with the outside air so that the air it contains can circulate and be replaced by fresh air.

Freight barrow-truck. Figs. 5637, etc. More commonly a supply *freight-truck*, which see. See also *Barrow-truck*.

Freight-car. Figs. 1-48, 229-379, 570-1131. A general term used to designate all kinds of cars which carry goods, merchandise, produce, minerals, etc., to distinguish them from those which carry passengers. English term, *wagon*. Figs. 348-51.

The cost of various styles of freight-cars, as established by the rules for interchange of traffic, has varied in different years as follows:

	1894.	1887.	1886.	1885.	1884.	1883.	1882.	1881.	1880.	1879.
Eight-wheel box car, 36 ft. long or over.....	\$325
“ “ box car, 34-36 ft. long.....	300
“ “ box car, 32 to 35 or 34 ft.....	275	\$275	\$450	\$450	\$500	\$520	\$575	\$575	\$450	\$425
“ “ box car, 32 ft. or under.....	240	240	430	430	480	500	550	550
“ “ stock car, 34 ft. long or over.....	300
“ “ stock car, 32-34 ft. or over.....	275	275	450	450	500	520
“ “ stock car, 32 ft. or under.....	240	240	435	425	470	490	550	550	450
“ “ gondola car, 20-ton or over, drop-bottom.....	220	220	400	400	430	450	525	525	375
“ “ gondola coal-car, 20 tons or over, hopper bottom.....	240	240	425	450	505	525
“ “ gondola coal-car, 25 tons or over, hopper bottom.....	275	275	450
“ “ gondola coal-car, 15 tons or less.....	180	180	375
“ “ gondola coal-car, 15 tons or over, hopper bottom.....	200	200	400
“ “ gondola, 31 or 32 ft. or over.....	150	150	350	350	380	400
“ “ ordinary gondola, less than 31 or 32 ft.....	125	125	325	300	355	375	475	450
“ “ ordinary flat car, 31 or 32 ft. or over.....	125	125	300	300	340	360	460	460
“ “ ordinary flat car, under 31 or 32 ft. long.....	100	100	290	300	330	350	425	425	350
Four-wheel gondola car, with truck and drop bottom.....	300	300	300	305	305	325	350	350
“ “ box car.....	230	230	230	230	230	250	300	300	250
“ “ ordinary coal-car.....	200	200	200	205	205	225	250	250	225
One pair four-wheel trucks.....	200	200	200	200	222	230	275	275	225	210
“ “ with metal transoms.....	250	250

NOTE.—Between the years 1887 and 1894 there was no change in the prices of cars.

box springs, with transoms, but no bolster or spring plank. The details are fully shown.

Frame. 1. The outline or skeleton upon which a structure is built up. In a car the framing is usually supposed to mean the sideframe as distinguished from the *floor* or *underframe*, unless otherwise so expressed. The leading types of freight-car frame are shown in figs. 229-376, etc. See *Bastard Howe*, *Bastard Pratt*. The leading styles of passenger-car framing are shown in figs. 419-604, and, in perspective view, figs. 531-8. The framing of street-cars is shown in figs. 5654-67 with the dimension of parts and over all. A marked innovation in the framing of passenger-cars is the introduction of iron in combination with wood. This is shown in the so-called *composite framing* of figs. 428-34, 523-30, 574-83; in the “*anti-telescoping*” *end-framing* of Pullman's Palace Car Company, shown in figs. 512-22 and 456-60; in the use of plates with *bolsters*, *end-sills*, *draft-timbers* of figs. 448, 451. These with the Challender Truss, figs. 568-9, which is considerably older, show considerable progress toward an iron or steel car-frame. In freight-car framing the general use of *fitch-plates* or *sandwich plate* and structural shapes for bolsters, spring planks, etc., should be noted.

2. (Of a door, ventilator, window-sash, mirror, etc.) The rectangular or curved border surrounding or inclosing it.

See *Berth-spring frame.* *Lever frame.*
Continuous truck-frame. *Match-striker frame.*
Cushion-frame. *Mirror-frame.*
Door-frame. *Name-panel frame.*
End-frame. *Register frame.*
Five-door frame. *Signal-bell frame.*
Grate-frame.

Frame cross-bar (“walk-over” seat). 39, figs. 3917-18. A short bar between the connecting-rails.

Framed spring-plank. Figs. 4813-14, etc. A spring-plank composed of several different pieces framed together.

Franklin Institute system of screw-threads. The *Sellers*

For varieties of freight cars, see *Car*.

Freight-car lock. Figs. 2736-41, 2747-59. A lock for fastening the doors of freight cars. The usual freight-car lock is simply a *hasp*, *staple*, *pin* and *seal*, but *stationary* or *fixed freight-car locks* are in increasing use.

Freight-car trucks (diamond type, which see). Figs. 4576-7, 4580-4749. (miscellaneous types.) Figs. 4750-4803.

Freight-house truck. Figs. 5635-41. A *freight truck*, which see. See also *Barrow-truck*, *Wagon-truck*.

Freight-train brake. *Brake-gear*. Figs. 1458-1531. See *Westinghouse brake*.

Freight-truck. Figs. 5635-41. A two-wheeled vehicle, universally used about stations for loading and unloading freight. A *baggage-barrow* is much the same. Baggage-barrow and freight-trucks are both sometimes designated as freight or baggage *barrow-trucks*. See *Freight barrow-truck*, *Freight wagon-truck*, *Push baggage-car*.

Freight wagon-truck. Fig. 5637. A four-wheeled vehicle for moving freight by hand.

Fresnel lantern. Figs. 3440-1. A lamp inclosed in a cylindrical Fresnel lens, which see. They are more used in marine than in railroad service.

Fresnel lens. Figs. 3440-1. A lens formed of concentric rings of glass or other transparent substances, one or both sides of which are bounded by spherical surfaces. The object of making a lens in this form is to reduce its thickness in the centre, and thus lessen the liability of having flaws and impurities in the glass, and also to reduce the absorption and aberration of the rays which pass through it. Such lenses are also made of a hollow, cylindrical form, and used to inclose signal lamps. The outside of the glass is formed of successive rings, the external surfaces of which are bounded by spherical surfaces.

What is known to the trade as a *semaphore lens* is a Fresnel lens with the inner surface concave.

Friction-block. See *Swing-hanger friction-block* and *Friction plate*.

Friction-plate. 1. The body and truck *side-bearings*, which see, are sometimes called *friction-plates*. See

Chafing-plate. Drawbar friction-plate. 2. A plate screwed to the wall to protect the wood work from chafing by the seat back arms when the seat back is tilted.

Friction-roller. A wheel or pulley interposed between a sliding object and the surface on which it slides to diminish the friction. See *Car-door hanger. Sliding-door friction-roller.*

Frieze. That portion of a passenger or street car body on the outside, between the cornice or eaves of the roof and the tops of the windows. The *letter-board* occupies this space.

Frieze-ventilator. See *Ventilator.*

Frieze ventilator-plate. A perforated metal plate placed on the outside of a frieze-ventilator to exclude rain and cinders from the car.

Front. See *Ash-pit front. Alcove-front. Water-alcove front.*

Front cylinder-head. 1. (Air pump.) 6, fig. 1689. For convenience of designation, the end of the cylinder opposite to the piston-rod is called the *front* end, and that adjoining the piston-rod, the *back* end, as in locomotives.

2. (Westinghouse tender-brake.) 5, fig. 1726.

Front face-plate (steel-tired wheels). See *Face-plate.*

Front seat-bottom rail (street-cars). 103a, figs. 5656. See *Seat bottom-rail.*

Front seat-rail. 1. (Street-cars.) 103, figs. 5656-67; 97, figs. 5654-67.

2. (English.) 104, figs. 501-4.

Frost deck-lamp No. 2 (Frost system of gas lighting). Figs. 3138, 3139. The gas flows from the carburetor through the *gas-arm*, 29, and needle-valve, 30, to the *regenerative casting*, 1, and thence to the *burner*, 7, from which it issues by means of the horizontal holes. Air to supply the flame enters under the *cone-top*, 15, and a portion of it passes through ports in the *regenerative casting*, where it is brought to a high temperature, and thence down through the *perforated flame-plate*, 8, to the upper side of the flame. The remainder of the air required passes through a series of small holes near the outer edge of the *top-plate*, 2, and taking a downward course cools the *glass-globe*, 12, and supplies the under side of the flame. The products of combustion pass upward through openings in the *top-plate*, 2, and *regenerative casting*, 1, and escape by means of the *flue*, finally leaving the car through the *smoke-bell* (fig. 3132).

In order to light the lamp, it is necessary to drop the *glass-globe* which is held by a *globe-ring*, 4, hinged to the *top-plate*, and this gives easy access to the burner.

Deck lamp No. 3. Figs. 3133, 3136. The gas flows through the *needle-valve* and *gas-arm* to the *gas-body* and thence to the *burner*, 24, fig. 5139, from which it issues from the lower ends of the small tubes. The air required to supply the flame enters through the *injector*, 27, and the perforations in the *air-controller*, 26. A portion of this air passes between the burner and *porcelain-cylinder*, 25, and passing downward supplies the upper side of the flame, while the remainder entering through the perforations in the lower part of the *controller* supplies the under side of the flame. The products of combustion pass upward through the *gas-body*, 1, *flues*, 10, and *ejector*, 6, and escape from the car by means of the *smoke-bell* (fig. 3132).

In order to light the lamp, it is necessary to press in the *injector latch*, 28, and drop the *injector* one notch. A lighted match or taper can then be introduced between the injector and the globe and the gas lighted, after which the *injector* must be pushed up into its former position.

Frost dry-carburetor system of car-lighting. Figs. 3109-59. The light in this system is produced by burning at the lamps a gas generated in the carburetors, which are placed on top of the car. The gas is simply air carrying a certain amount of gasoline vapor. The air is taken from the air-brake service; the gasoline, absorbed

by wicking, is contained in the carburetors, and the object of the details of this system is to bring these two elements together and thus produce a gas. Figs. 3109-10 and figs. 3112-24 show how the supply of air is taken from the end of the auxiliary reservoir and enters the *air-tank* after passing through the combined *dust-guard and check-valve*. This valve frees from dirt the air which passes through it and acts as a check to retain the supply of air stored in the tank at such times as the pressure is withdrawn from the brake system. The *air-tank* also serves as a storage reservoir, and its capacity is such that, when charged to the pressure ordinarily carried in the air-brake system, the air contained therein will sustain the lights several hours after the car is detached from the train. A *tank-valve* placed at each end of the tank controls the retention of air. The air-pipe conducts the air to the saloon where the *air-gage* indicates the pressure in the air tank, and the *closet-valve* directly controls the supply of air to the carburetors. From the closet-valve the air passes through the *regulator*, where it is reduced in pressure to 1½ pounds, which pressure is practically constant on all parts of the system beyond this point. The course of the air next taken is through the mercurial-check-valve and the *roof pipe* to the *carburetors*. After entering the *carburetors*, the air moves slowly through a spiral passage, sixty feet in length, packed solidly with cotton wicking saturated with gasoline, and absorbs sufficient of the volatile oil to produce the desired gas which is consumed by the lamp directly beneath. This system is in general use on the Pennsylvania, Norfolk & Western, and several other prominent roads. The property and patent rights of the system having been recently acquired by a rival gas-lighting company, its future is uncertain. For lines which are isolated and have no plant for compressing gas, as is required for the *Pintsch system*, the *Frost system* will find favor.

Frost gas-lamps, bracket and vestibule (Frost System of Gas-Lighting). Figs. 3134, 3137, 3140. The burners used upon these lamps are strictly modified forms of the *Argand-burner* in common use. The air to supply the flame enters the lamp through the perforated *plate or gauze*, 3, near the top of the lamp and flowing downward between the *glass chimney* and the *globe*, passes through openings in the *burner*, 7, and *burner-gallery* and supplies both the center and the outside of the flame. The ring which holds the globe of the vestibule lamp is hinged to the lamp-body, and in order to reach the burner it is necessary to drop the globe and raise the chimney. To light the bracket lamp, a shutter may be opened in the metal bottom of the lamp and a taper or match introduced between the burner and its gallery, thus rendering it unnecessary to raise the chimney in order to light the lamp.

Fruit car. Figs. 5-7, 11-12, 257-62, etc. A car of special design for the carrying of fruit and other perishable products requiring ventilation. The ventilators are so arranged that they can be opened and closed while the car is in motion, so that there may be a constant stream of fresh air passing through the car. Ice is not used generally, but it is coming into use in cars carrying fruits from California to eastern markets.

Fulcrum. 1. "In mechanics, that by which a lever is sustained, or the point about which it moves."—*Webster.* See *Brake-lever fulcrum.*

2. (For propelling-lever of hand-car.) 32, figs. 5592-00.

Fulcrum-bolt (Janney platform). The bolt passing through a *fulcrum ferrule* in the knee-timber and forming the fulcrum upon which the *yoke-lever* works.

Fulcrum-ferrule (Janney platform). See above.

Fulcrum-hanger carriers. Figs. 5003-6. A cast bracket which is bolted to the iron transom of a six-wheel truck to carry the *Brake-lever hanger-bridge*, as shown in figs. 1540-2.

The *Brake-lever connection-rod*, 4, is sometimes called a *Brake-lever fulcrum*, hence the name.

Funnel. 1. "A vessel for conveying fluids into close vessels; a kind of inverted hollow cone with a pipe; a tunnel."—*Webster*. See *Filling-funnel*.

Furnishings. A term designating the smaller fixtures, hardware, etc., which are usually applied to cars after they shall have left the paint shop. The engravings are very nearly alphabetical in their arrangement and a complete list is given in the index to engravings, which see.

Furniture car. Figs. 4, 247-50. An extra-sized box car. The dimensions given in the engravings are not unusual. More particularly designed for carrying furniture and made extra large.

Furring. 59, figs. 435-73, etc. Pieces of wood placed in a wall or other position to nail something to, as a panel or molding. The term is also applied to angle blocks glued or nailed in the inside angle of wood work, where strength and stiffness are required. See *Blocking* and *Furring-brace blocks*. See *Panel-furring*.

Furring-blocks. 59b, fig. 538. See *Blocking* and above.

Furring-brace blocks. 205, fig. 560. Blocks of triangular cross section glued in the angles between the sheathing and furring to give it greater stiffness.

Fusee or fuse. A tube, casing, rope or ribbon filled or saturated with a slow burning composition, as nitre, sulphur, etc., and used primarily for firing blasts. They are also made to give warnings to approaching trains. They are carried on a train and dropped or placed upon the track at night to warn other trains following that a train has passed that point within a short time before. Trains meeting with a fusee burning on the track are required to stop and wait until it has burned out.

Fusee. The cone or conical part of a watch or clock, round which is wound the chain or cord. It is a very ancient mechanical contrivance, and is made of a cone form in order to equalize the power of the spring, the leverage of the cord increasing as the resistance of the spring increases and *vice versa*. A fusee is shown in fig. 4207. See *Berth-spring fusee*.

G

Gage. 1. (Of track.) The distance in the clear between the heads of the rails of a railroad; 4 ft. 8½ ins. is the *standard gage*; if greater than this by more than ½ inch, a *broad gage*, which see; if smaller, a *narrow gage*, which see. *Wide gage* usually means a minor and irregular or exceptional enlargement of a given fixed gage, in distinction from *tight gage*, a corresponding contraction.

2. A tool or instrument used as a standard of measurement of pressure or size.

See <i>Air-gage.</i>	<i>Screw pitch-gage.</i>
<i>Cylindrical-gage.</i>	<i>Screw-thread gage.</i>
<i>Pressure-gage.</i>	<i>Whitworth-gage,</i>
<i>Screw-gage.</i>	etc.

Gagger. A *chaplet*, which see.

Gain. "In architecture, a beveling shoulder, a lapping of timbers, or the cut that is made for receiving a timber."—*Webster*. In car work the term generally means a notching of one piece of timber into another. *Boxing* is almost a synonymous term. The timbers are *boxed out* in order to *gain* them into each other. A *mortise*, which see, is usually deeper and does not extend clear across the stick.

Galvanized iron. Sheet iron covered with sal-ammoniac, after first cleaning it in a bath of dilute acid, coated with zinc by immersing it in bath of the liquid metal. An amalgam of 11.5 zinc and 1 mercury is sometimes used. It is usually made in sheets about 2 feet wide by 6 to 9 feet long, and its thickness measured by its number, wire-gage (W. G.). See *Kalaminc iron*.

Ganet air-brake. A system of air-brakes for electric and cable cars, in which the air is compressed by a com-

pressor operated from the axle of the car by an eccentric. The apparatus includes (1) an air pump or compressor to furnish the compressed air; (2) an eccentric and connecting rod to work the piston of the air compressor; (3) a controlling valve by which the brakes are applied and released; (4) a jam cylinder or brake-cylinder to move the brake levers; (5) a main reservoir; and (6) an auxiliary reservoir.

Gardner's geared seat-arm. Fig. 3995. A device for giving a backward slope to car-seats with reversible backs by a rack and pinion movement in the seat-arm and seat-arm pivot. Several other devices for the same purpose exist. See engravings.

Garnish rail (English). 111, figs. 501-4. A horizontal piece of ornamental wood curved on the upper surface and placed on the inner side of the mouth of the slot into which the movable window falls. It carries the *glass string roller*, which see.

Gas-burner. Fig. 3209-11. "The jet-piece of a gas-lighting apparatus at which the gas issues and combustion takes place."—*Knight*. A system of gas burning has been in use on the Pennsylvania Railroad by compressing ordinary city gas. Another and more elaborate system is the *Pintsch*, which see, figs. 3160-3251.

Gas lamps. See *Frost-bracket, deck and vestibule lamps*; and *Pintsch lamps*.

Gasolier. A recent attempted addition to the English language signifying a chandelier burning gas. It is unauthorized by good usage.

Gas-pipe. See *Pipe*.

Gas-pipe fittings. Figs. 3161-98. See *Pipe-fittings*.

Gasket. "A strip of leather, tow, or textile fabric, to form a packing or calk a joint."—*Knight*. This term is also applied, probably with perfect correctness, to sheets of lead, copper, etc., used for the same purpose. The Westinghouse engine and air-pump gaskets, 36-41, figs. 1689, etc., are copper. A peculiar gasket or packing-ring of rubber faced with lead to prevent the gas injuring the rubber is used in all joints of the *Pintsch* gas apparatus, figs. 3218-21.

Gaskets take their name from the parts which they are used with.

Gate. 1. See *Platform-gate*.

2. (Of a casting-mold.) The opening through which the melted metal is poured. Also called *Ingate*.

Gates. (For open suburban cars.) Figs. 3801-3. Gates or bars at either end of the transverse seats of an open car, connected by a bar so that by one movement of a lever all the gates on one side of the car can be opened, facilitating the rapid unloading of a car. See *Platform-gate*.

Gauze. See *Wire-gauze*.

Gear. 1. Apparatus: In mechanics the term is used to designate a combination of appliances for effecting some result, as *valve-gear*. See *Brake-gear, Draw-gear, Swing-motion gear*.

2. Wheels are said to be *in gear* when they have cogs interlocking.

Geared seat-arm. Fig. 3995. See *Gardner's geared seat-arm*.

Gear-wheel. 7, fig. 207. Any cogged wheel is a gear-wheel, but the term is usually restricted to the larger one of two cog-wheels in gear, the lesser one being called the *pinion*. The *gear-wheel* is also called *spur-wheel*.

Gelatinized fiber. Another name for *vulcanized fibre*, which see.

"**Gem**" door-spring. Fig. 2817. See *Door-spring*.

General Electric Company's Electric Motor (For street cars). Fig. 5675.

Generator coils (Heaters, Baker's, Gold's, etc.). Figs. 2874, 2894, 2906-7, 2920, 3002-3, 3006. Wrought-iron pipe coiled into a variety of spiralic shapes as shown in the figures, and put into the fire-pot of a heater, to heat the

water they contain and create a circulation through the *hot-water pipes* of the car. Among the different types may be mentioned the *Expanding generator coil*, figs. 2894, 2906, in which the diameter of the pipe increases as the heated water ascends in it; the *Gold duplex-double coil*, figs. 3002, 3006, which has a steam-pipe inside of the hot-water coil, to be used when steam from the locomotive is used to heat the water instead of a fire in the heater.

Gib (for journal-bearings). A *journal-bearing key*, which see. This word should not be pronounced *jib*; the *g* has the hard sound.

Gib and key. A fastening to connect a bar and strap together by a slot common to both, in which a E-shaped *gib* with a beveled back is first inserted and then driven fast by a taper *key*.

Gibbs-Johnson Steam Coupler. Details of construction of this coupler, with its proper position on the car, are shown by figs. 3037-78, 3046-50. This coupler is of the same type as the Westinghouse air-brake coupling. It is automatic in action, and tight under pressure. The gasket, No. 666, can be renewed without removal of coupling. The blowing off of hose is prevented by the device shown on figs. 3049-50.

Gibson fastening (English). Figs. 5341 and 5337. One of the earliest applications of the principle of securing a tire to a wheel by means of clips instead of bolts, studs or rivets. The original Gibson fastening shown in fig. 5341 has been superseded by that shown in 5337, which is a very common fastening. Figs. 5274-9, 5292-99, 5322-4, are modified types of the Gibson fastening.

Gimlet-pointed screw. The common *wood-screw*, which see, of carpentry and joiner work, having its screw cut to a point like a gimlet, so that it can force its own way into wood.

Girder. "In architecture, the principal piece of timber in a floor. Its ends are usually framed into the summers, or breast-summers, and the joists are framed into it at one end. In buildings entirely of timber, the *girder* is fastened by tenons into the posts."—*Webster*.

"The term *girder* is restricted to beams subject to transverse strain, and exerting a vertical pressure merely on their points of support."—*Stoney*. The term is almost synonymous with *truss*. Thus, engineers speak of a "Howe *truss*," a "Pratt *truss*," a "Warren *girder*," and a "lattice *girder*." The distinction is that a *truss* consists of separate parts held together by pins, or even simply by pressure, which may be taken down and re-erected; whereas a *girder* is a single solid structure, either all one solid piece (*rolled girder*), or of plates riveted together (*plate girder*), or of combined plates and riveted lattice work (*lattice girder*).

Girt (snow-plow). 5, 6, figs. 410-3. A name for a small wooden girder, used in roof and bridge frames. Applied in snow-plows to cross-tie timbers, on top of the sills.

Girth, figs. 229-66. A *belt-rail*. A long horizontal piece of wood on the side of a box-car body fitted to the posts and braces so as to embrace them, placed about half-way between the floor and the roof. The *end-girth* is a similar stick across the end of the car. The inside lining reaches up to the girth.

Girth tie-rod. Fig. 51. Belt-rail tie-rod. A horizontal rod extending from the door to the corner-post along the girth of a freight-car and intended to tie the two posts together.

Gland, 28, fig. 1689, 97, figs. 1691-2. A cover of a stuffing-box, as for a piston-rod, etc. See *Piston-rod packing-gland*.

Glass. See *Window-glass*. *Cut-glass*. *Sand-blast*.

Glass-frame bottom sash-rail (English.) See *Door-light bottom sash-rail*.

Glass-frame stile (English). See *Door-light stile* and *quarter-light moulding*.

Glass seal (seal lock). Fig. 3897a.

Glass-string, or glass-strap (English). 204, fig. 501. A leather strap by which the window in the door of a carriage is raised or lowered. The strap is pierced with a number of holes which fit a small brass or ivory knob placed on the door immediately under the *glass-string roller*, which see.

Glass-string roller (English). 195, fig. 501. In a carriage, an ornamental roller attached to the upper edge of the *garnish-rail* in a door. The leather strap (*glass-string*) by which the window is raised and lowered passes over this roller.

Glass water-gage. A gage consisting essentially of a vertical glass tube connected at top and bottom with a boiler so as to make the height of water therein visible.

Globe (of Pintsch gas-burner). Fig. 3200. A globe of hemispherical form, admitting air only from the top. It is an almost universal type of car lamp-globe in Europe. A *glass-bowl*.

See *Adjustable globe*.
Fast lamp-globe.

Lamp-globe.
Loose-globe.

Globe-chimney. Figs. 3430-4. A *lamp-globe chimney*, which see.

Globe-holder. 7, figs. 3261-3317, for *lantern*, fig. 3353. Any contrivance for holding a globe on a lamp. Usually it consists of a metal ring, at the base of the globe, on which the latter rests, and to which it is fastened with springs, screws, or by the pressure of the globe-chimney on top when the latter is adjustable. See *Adjustable* and *Detachable globe-holder*.

"Globe" lamp-shade or lamp-globe. Fig. 3429. See *Lamp-shade*.

"Globe" ventilator. Figs. 4300-1, 4312-3. A ventilator of spherical form, with annular openings which produces an induced exhaust current in whatever direction a current of air strikes against it. They are made *erect* and *horizontal*.

Glue. A preparation from the hoofs, horns and hides of animals, washed in lime-water, boiled, skimmed, strained, evaporated, cooled in molds, cut into slices and dried upon nets. If good, it is a hard cake, of a dark but almost transparent color, free from black or cloudy spots and with little or no smell. The more transparent and amber colored the better. Inferior glue made from bones will almost entirely dissolve in cold water; other kinds are contaminated with lime. Glue is better for remelting. The strength of glue for common work is increased by adding a little common chalk.

Glue size. One pound of glue in a gallon of water. *Double size* has about twice this quantity of glue. *Patent size* is a kind of gelatine.

Gold's compression coupling. Fig. 3016. In the "Compression" Coupling, the seats are immovably in the head of each body and are held in position by thimbles, instead of being mounted on circular diaphragms.

In order to use the internal pressure of steam to force the seats together there is a diaphragm on the outer side of each coupling head, so situated that the internal pressure thrusts the diaphragms outwardly. To utilize this internal pressure on the diaphragms to bring the seats together a lever arm is made so that one end of the arm is the lug or tooth which engages with opposite coupling body, and the other end enters a recess and is held in place by a set screw. As the internal pressure of the steam is exerted on the diaphragms from the interior of heads, they are thrust outwardly and press the inside of the lever arm. The arms being pressed outwardly, will draw the seats to. This constitutes the "Compression" theory, from which the name. The movable arm is adjustable. The Compression Coupling interchanges with the Gibbs Steam Coupling.

Gold's interchangeable coupling. Fig. 3017. The coupling consists of two bodies, exactly alike, fitted with case-hardened, steel discs, or special composition discs. The joint is made by the faces of the discs being brought

together. In the arm of each coupling is an adjustable lug, which, sliding around an inclined plane at the back of each coupling body, tightens as it is allowed to drop, the principle being that of a gravity lock. A set screw and lock nut are applied to the arm for the purpose of taking up any wear. The couplings uncouple automatically when cars are drawn apart, the coupling being brought to a horizontal position again, and the lug dropping down the inclined plane. A chain prevents the coupling dropping onto the track.

Each body of the coupling is fitted with an *automatic relief-trap* so that when steam is shut off the traps discharge the water while hot without having to be uncoupled.

Gold's platform-gate. Figs. 3797-8. A gate extensively used on elevated and other rapid-transit roads. The two gates on one side, of two cars coupled together, can be opened simultaneously by one trainman. The details are shown in the figures.

Gold's systems of car-heating. Figs. 2996-3023. Several systems of car-heating designated as the *Double-coil hot water-circulating system*, the "Plain-pipe system" (see *Direct steam-heating system*), the "*Steam-heat storage system*" (see *Direct steam-storage systems*), the *Duplex double-coil overflow system*, the *Double-coil jet system*, and the *Duplex double-coil jet system with sediment-well and blow-off*.

Gold's universal straight-port steam coupling. Figs. 3013-15, 3021-2. A steam-hose coupling somewhat resembling the *Sewall coupling*.

The coupling is effected by locking arms or lugs, which project beyond the end of the body, and engage with the projecting rollers and stud on the opposite side during the act of coupling. To couple, the heads are brought together so that the locking projections on either side engage with one another; then the bodies are tilted downward, bringing the seats together.

To insure the bodies locking firmly together, a spindle or stud is cast on the side of each body, and a roller is placed over the stud, so that when lugs of coupling bodies engage with the rollers they turn on the studs and the friction is reduced to a minimum.

The seat is made of the Asbestos composition, formed externally as a segment of a sphere, and mounted in a tubular metal thimble or ring, which is made with two opposite guide fingers projecting inwardly and engage with the base of the socket in coupling head. This limits the movement of the seats.

This coupling interchanges with the *Sewall*.

Gondola-car. Figs. 21-26, 298-324. A flat-car inclosed with low *side-plank*, usually fixed, but sometimes hinged so that they can be let down, and in some cases removable. They are made with drop-bottoms and drop-ends, so that they may be used for lumber as well as coal. They are then made with *single drop-doors* as in figs. 22-3 and 302-4, or with *double drop-doors* as in figs. 21 and 298-301. When built for coal alone they are built with *hopper-bottoms* and inclined floors as in figs. 305-9. The hoppers built are *pyramidal* or *box hoppers*, a type of the former being shown in figs. 24-26 and 310-15, and of the latter in figs. 305-9. A *double* or *twin-hopper gondola* saves nearly as much shoveling as any of the coal-cars, and may also be used for lumber. They are in increasing favor and shown in figs. 26 and 310-20.

Gong. A *signal-bell*, which see.

Goods wagon (English). Figs. 348-5. American equivalent, *freight-car*. See *Wagon*.

Goose-neck (Eames coupling). 16, figs. 1677-9. A *brake-hose nipple* connecting the coupling-hose to the brake-pipe.

Gould buffer and continuous platform. Figs. 1380-1427, 2296-2300. The engravings show the application of the Gould buffer and platform arrangement to a Miller platform, which application is deemed the best. The fram-

ing is essentially the same as the *Miller*, except that the *platform truss-beam* is made longer so as to cross the *intermediate* and *platform sills*, the addition of two more *platform truss-rods* and the addition of two *buffing-sills* underneath the *intermediate-sills* and between the *platform truss-beam* and *body-bolster*. These additional parts greatly increase the buffing strength of the platform and greatly assist in preventing the platform from sagging under the increased load due to the vestibule.

The buffing arrangement comprises a *center* and two *side buffer-stems* connected by a short *buffer-plate*, or by a long vestibule *buffer-plate*. These *buffer-stems* pass through *guides* and *thimbles* and are backed up by *spiral buffer-springs*. The Gould coupler with its long shank is connected with the long *center buffer-spring* by a *pressure* or *push-bar* in such a manner that when the drawbar and coupler are pulled out the push-bar acts against the *buffer-spring* and tends to force out the *center buffer-stem* and the *buffer-plate*.

The coupler and shank being so long must have some lateral motion and a wide carry-iron is recommended with a Miller side-spring, as shown in the engraving, or with lateral springs, as shown in figs. 1302-4 and 2281. This buffer and platform accompanies and is a part of the Gould vestibule.

Gould car-coupler. Freight, figs. 2141-4; passenger, figs. 2246-51.

Gould pendulum vestibule. Figs. 2420-2, 2431-6. A vestibule designed to evade the original vestibule patents, the principles of which are described under *Vestibule*. It consists of a *face-plate* (1) with a *diaphragm* (2) and a *back face-plate* (4). The face-plate is made up of several pieces and consists of an *outer plate* (1), hinged, as shown, so as to permit lateral motion or vertical motion. It is kept forced out by the *back gravity-bar* (28a) by which it is supported. The *face-plate* is hinged and supported also by the *front face-plate gravity-bar* (41) and is prevented from frictional resistance against its opposite plate by *clips* or *lugs* (38) and (43), riveted to one face-plate and covering or engaging the opposing face-plate and called *face-plate guides*. Lateral motion is opposed by a system of levers and a *restraining-chain* (26), which latter limits the lateral swing of the *face-plate*, as well as its longitudinal motion. These are so arranged that the weight of the *face-plate* is utilized to keep it in position. The link motion gives all the lateral motion necessary to go around curves and to permit lateral oscillation.

The face-plate is kept crowded out by its own gravity supported upon the *back gravity bar* (28a) hinged at (35), a point several inches outside the gravity line of the face-plate. The buffer and platform are continuous, and have the usual spring pressures devised for the purpose. A *push-bar* connects the buffer spring to the drawbar, so that when the coupler is drawn out the face-plate is made to follow, and the springs of both the buffer stem and drawbar assist one another. The top of the face-plate is held from falling out too far by the *face-plate retaining-chain* (26) which passes through the *sheave* (37). This vestibule was first applied to cars in 1892, and is in exclusive use on the Vanderbilt systems of railroads.

Gould platform. See *Gould buffer and platform*.

Gould tender-hook. Figs. 2145-9.

Governor (Westinghouse brake). 3g, figs. 1699-1707. See *Pump governor*.

Grab-handle and bracket. 30, 31, figs. 5654-67.

Grab-irons. 60, figs. 229-66, etc. Also termed *corner handles* or *ladder-handles* and *hand-holds*. The handles attached to freight-cars for the use of trainmen in boarding the cars. They are often more definitely specified as *roof*, *side* or *end grab-iron*.

For Recommended Practice of M. C. B. Association with regard to *hand-holds* or *grab-irons*; see *Hand-holds*.

The grab-irons or hand-holds shown in figs. 5546-7 are in the positions recommended.

The term *handle*, though often used to designate these attachments, is not strictly appropriate to such a part, nor is it so widely in use as grab-iron. See note to *handle*. Similar parts on passenger-cars are called *hand-rails*, which see.

Graduated spring. Figs. 5218-20. A form of compound spring in which only a certain number of the individual spirals come into action with a light load and the others only under a heavy load. Another method of accomplishing the same end, graduating the resistance of the spring to the load placed upon it, is the use of the *keg-shaped* or *spool-shaped* spring, fig. 5242. Under a load the part of larger diameter closes first and that of smaller diameter is much stiffer. These springs are much used on horse-cars, but rarely for steam-cars. Graduated springs have formerly been constructed by combining rubber and spiral springs, but they are now out of use. Graduated springs have been superseded by single and double nest coil, of equal length, and few, if any, are being applied to new construction.

Graduating spring. 22, figs. 1706-7. (Triple-valve of Westinghouse brake.) A spiral spring which acts against a collar on the graduating-stem to hold the latter against the triple-valve piston when it is forced downward.

Graduating-stem (triple-valve of Westinghouse brake). 21, figs. 1706-7. A slender rod or pin which works in a hole drilled in the center of the triple-valve piston, and which, by the movement of the latter, opens and closes communication from the chambers above and below the piston.

Graduating-valve (of Westinghouse triple-valves). 7. Figs. 1706-7. See above and *Triple-valve*.

Graduating-valve (Consolidated car-heating). Fig. 2975. A valve constructed so as to open slowly and designed to give better regulation of the temperature of the car after a car is heated. This is accomplished by attaching a movable piston to the valve-stem, which has a loose fit in an inwardly projecting ledge cast with the valve-case. As the valve opens the piston exposes V-shaped notches above this ledge through which steam passes up under the valve-seat in its course to the heating apparatus opening the valve wider, exposing more of the V-shaped ports and increasing the flow of steam. When the valve is closed the steam is entirely shut off by means of the valve-disc and seat attached to the same stem.

Graham draft-rigging or gear. Figs. 1659-75. A draft-rigging that has been in much favor which employs a *tail-bolt*, instead of a *yoke-strap*. It has two check-castings which engage in the *draft-sills* and *draft-timbles*, and in these two *timbles* or draw-bar followers fit, through which the tail-bolt passes. These, with two *follower plate-straps*, 1 *carry-irons*, three *strap-plates*, the *chafing-plates* and filling pieces between center-sills, constitute the attachments.

Graham-Mitchell Draft-rigging. Figs. 1976-2006. This is a modified form of the *Graham draft-gear*, so that a yoke or strap-pocket can be used instead of a tail-bolt. The check-castings are essentially the same, except that they are cored out so that the yoke may pass through them. The *timbles* or *followers* are the same as are the other parts. A hole is cut through the floor so that the bolts of the yoke may be taken out.

Grain-car. A box car with tight inside *grain-doors*. Nearly all box cars are provided with them.

Grain-door. 62, figs. 254 and 1866-1935. A close-fitting movable door on the inside of a box car by which the lower part of the door-opening is closed, when the car is loaded with grain, to prevent the latter from leaking out. Such doors are usually made so that they can be thrown over on one side of the doorway, or suspended from the roof, and thus be out of the way when they are not used. A great variety of mechanical devices are used for accomplishing this purpose, of which the *Van Liew grain-door*, figs. 1866-69, *Chicago grain-door*, figs. 1870-5, *McGuire grain-door*, figs. 1876-95,

Decatur grain-door, figs. 1896-1926, *Chicago and Northwestern Ry. grain-door*, figs. 1927-8, *The Corrugated Steel grain-door*, figs. 1929-35, are shown with names of parts.

Grain-door flap. Fig. 619. The upper part of a grain-door. Hinged horizontally with the door proper.

Grain-door lock (Van Liew grain-door). 6, figs. 1866-9.

Grain-door rod. K, figs. 1876-95. An iron rod attached to the door-posts on the inside of a box car, to which a grain-door is fastened or hinged. The door and rod are generally arranged so that the former can be moved to one side and out of the way when the car is not loaded with grain. In other styles the door slides upon the rod to the roof and is there suspended.

Grate. (Baker heater.) Figs. 2881, 2893a, etc.

(Spear caboose stove.) 5, and 26, figs. 3075-3105.

(Erie caboose stove.) Figs. 3061-2.

A frame of iron bars for holding coals in a stove, fire-place, etc. It is usually capable of a sliding or rocking motion, or both, to clear away ashes and clinkers. See *Anti-clinker grate*. *Safety-grate*.

Grate-bar (for Erie caboose stove). Figs. 3067a-b. A cast-iron bar below the grate, and on which the latter rests.

Grated-door. Figs. 5, 11, 257-60. A door consisting of a wooden frame with iron or wooden bars, used on cars for carrying fruit, live stock, etc.

Grate-shaker (Baker-heater). Figs. 2880, 2893d, 2918. An iron bar which can be attached to a grate to move it in shaking the fire.

Grate support (Baker-heater). Figs. 2882, etc. A crow-foot shaped bracket, fastened to the sides of the ashpit to carry the *fire-grate*.

Grating.

See *Clinker grating.* *Ventilator grating* (fruit-car).
Ice-box grating (refrigerator-cars). *Window grating.*

Gravel-car. Figs. 28, 214, 328-31, 336-8, 339-42. A car for carrying gravel; usually either a *tip-car* or a *flat-car*, the latter most used. They are often fitted with a central rail, over which a *ballast plow*, drawn by the locomotive after detaching it from the cars, works to unload the cars. Sometimes a hoisting plant is mounted upon one of the cars, for moving the plow.

Gravity relief-trap (Gold's car-heating). Figs. 3007, 3019-22. An auxiliary trap, automatic in its action, which is closed by the escape of steam and held closed by the steam pressure. When the pressure is removed the weight of the valve stem tips the valve and allows the escape of the water of condensation. The pressure under which it closes is dependent on the weight of the valve stem.

Grease axle-box (English). 34, figs. 348-51, and 501-4. An axle-box which is lubricated from above by a grease composed of tallow, soda, and water, which is solid at ordinary temperatures and melts should the box get warm. This form is being superseded by the *oil axle-box*, which see.

Grease-box. A *journal-box*, which see.

Grease-chamber (English). 35, figs. 501-4. A cavity above the journal-bearing which contains the lubricating material in a *grease axle-box*, which see.

Grille (interior decoration). Figs. 3647-55. Generally a piece of wrought work in wood or metal for decoration. Used in the place of panels, over door ways and in bulkheads and sometimes employed as brackets as at G, figs. 2452-3a.

Grommet. Figs. 2853-4. "A ring formed with spliced rope (*Nautical*). The separate parts of any metallic eyelet are known as *grommets*. The two grommets, when compressed together (with a *setting-die*), form the *eyelet*.

Ground glass. Glass whose surface has been roughened by mechanical or chemical process so as to break up the light passing through it and destroy its transparency.

Several processes exist: by the wheel, sand blast, rotating with pebbles, or by fluoric acid. The sand-blast is at present most commonly used.

Group-spring. Figs. 5199-5213. A spiral car-spring formed of a number of separate springs, single or nested, united together by a common pair of *spring-plates*. It is called a *double*, or *two-group*, a *three-group*, *four-group spring*, etc., according to the number of separate springs.

Guard. 1. See

<i>Dash-guard.</i>	<i>Heat-guard.</i>
<i>Door-guard.</i>	<i>Lining-guard.</i>
<i>Draw-timber guard.</i>	<i>Mirror-guard.</i>
<i>Dust-guard.</i>	<i>Window-guard.</i>
<i>Fender-guard.</i>	

2. (English.) American equivalent, *conductor*. A railway official traveling with and having charge of a railway train. He unites the functions of the conductor, baggage-master, express agent, and brakeman, but seldom collects or nips tickets, and never issues them or receives fares. An *assistant guard* is sometimes, but not always, carried.

3. (For lanterns.) The exterior wire cover surrounding the *globe* and protecting it from accident. They are termed either *single*, *double*, or *triple guard*, according to the number of horizontal wires.

Guard-band (street-cars). See *Door-guard band*.

Guard-fender. See *Fender-guard*.

Guard lining-strips. 53S, fig. 281. Horizontal bars or strips which are placed in a car to keep freight from a door, ice-box, ventilator, etc. When placed vertically as they usually are they are termed *guard-posts*.

Guard-posts (fruit-car). A row of posts standing inside of the ventilators and serving as a fender for the load packed within so as to prevent obstruction to the ventilators.

Guardrail (street-car). 41, figs. 5654-67. See *Fender-rail*.

Guard-rail and frog-wing gage. Fig. 5484. The guard-rail and frog-wing gage shown were adopted as standard in 1894, to define the dimensions of track to which M. C. B. standard wheel and flange gages have been made to conform.

Guard's van (English). American equivalent, *caboose* or *baggage-car*. See *Brake-van*.

Gudgeon. The bearing portion of a shaft, especially an upright wooden shaft. A rude journal-bearing for slow motion. See *Screw-coupling nut and gudgeon*.

Guide. "That which leads or conducts."—*Webster*.

See <i>Bell-cord guide.</i>	<i>Drawbar guide.</i>
<i>Bell-strap guide.</i>	<i>Glass-plate guide.</i>
<i>Brake-lever guide.</i>	<i>Journal-box guide.</i>
<i>Brake-rod guide.</i>	<i>Stop-bar guide.</i>
<i>Dead-lever guide.</i>	<i>Strap-hanger guide.</i>

Guide-casting. 27, figs. 3968-73. A strip or plate of metal screwed to the wall or arm-rest of a seat for the striker arms to rub against to save the wood. Called also a *Friction-plate*, figs. 3967-76.

Guide-bar. 1. See *Truck-bolster guide-bar* or *column*, 37, figs. 4580-4739, and figs. 4698-0, 5184-5.

Guide-block. See *Truck-bolster guide-block*.

Guide-rail. A *door-track*, which see.

Gum-spring. A term used by Philadelphians to designate *india-rubber car-springs*, which see.

Gun-car or cannon-car. Figs. 4804-5. A specially heavy car for transporting ordnance, often having sixteen wheels.

Gunpowder-van (English). A covered vehicle adapted to run on freight trains, and specially fitted for the conveyance of explosives. The outside of the body is made of or covered with iron plates to guard against fire, and the inside is lined with sheet lead to prevent any sparks being caused by friction. The door-openings are lined with felt to secure a tight joint.

Gun-shaped lamp-chimney. Fig. 3421. See *Lamp-chimney*.

Gurring-piece (snowplow). 10, figs. 410-13. Probably from *gurr*, a fort, hence a piece built out to protect or fortify a structure. In a snowplow, timbers bolted to the posts to build out and give shape to the sides.

Guy. A rope used as a stay.

Guy-rings (of a derrick or crane). 20, figs. 392-3. Rings attached to the head-block at the top of the mast to which guy-ropes may be attached.

Guy-rope (for leaders of pile-driver car). 35, figs. 401-4.

H

Hale-and-Kilburn car-seats and upholstery. Figs. 3901-3947.

Hair. See *Curled-hair*.

Half-elliptic spring. See *Spring. Elliptic spring*.

Half-elliptic spring-bearing. A cast or wrought-iron plate.

Half-oval washer (Janney coupler). The washer of the catch-spring bolt.

Half-round bar spiral-spring. See *Spring. Spiral-spring*.

Hammer of a pile-driver car. 1, fig. 401-4. The heavy weight (4000 to 4500 lbs.) by which piles are driven. It falls between the *leaders* and is provided with a *hammer-eye* or *clevis* to which the shears of the *hoisting-rope* or *hammer-rope* are attached. In England called a *tup*, which also means a ram or male sheep.

Hammered car-axle. An axle made by forging under a hammer. Sometimes called *faggoted-axle*. Hammered axles are made either of slabs or bars of iron, which are piled together and then heated, welded and forged into the form of the axle by hammering, under a steam hammer. The slabs are made by piling small pieces of scrap-iron, which are then heated and welded together by forging, forming a *scrap axle*. The bars used for making such axles are sometimes made of rolled iron *muck-bars*, which see, and hence called a *muck-bar axle*.

Hammer-eye, or clevis (of a pile-driver car). 2, figs. 401-4. See *Hammer*.

Hammer-rope (for pile-driver car). 39, figs. 401-4. See *Hammer*.

Hammer-rope pulley (for pile-driver car). 40, figs. 401-4. A pulley sometimes attached to the floor of the *swing-platform* directly in front of the hoisting-gear.

Hammock (sleeping-car berth). 52, fig. 2411. A light small hammock of twine in which to put wearing apparel in a sleeping-car berth. One is furnished to each berth.

Hand-car. Figs. 5581-5634. A small and light car arranged with cranks or levers and gearing so that it can be propelled by hand by persons riding on the car. One of these cars is provided for each *section* of 3 to 6 miles of track. Originally the *crank hand-car*, fig. 5616, was most used, but the *lever hand-car*, figs. 5581, etc., has now almost wholly supplanted it, as being much less laborious. *Inspection hand-cars* are a special variety, either from their fitting up, as those in fig. 5586-7, or from their lightness, as the *three-wheel hand-car*, figs. 5605-11. Hand-cars for regular section service weigh from 450 to 600 lbs., generally about 500 lbs. *Telegraph hand-cars*, figs. 5611, 5615, are a lighter class for the use of telegraph linemen.

Hand-car lever or propelling lever. 19, figs. 5592-00.

Hand-car truss-rod. 26, figs. 5592-00. A transverse or longitudinal rod by which the floor-frame of a hand-car is trussed.

Hand-car wheel. Figs. 5620-34. A light wheel for hand-cars, with cast-iron rim and hub and wrought-iron spokes, or sometimes with a wooden center.

Hand derrick-car. Figs. 7780, 206, 392-3. See *Derrick-car*.

Hand-hold. Another term for *grab-iron*, which see. The M. C. B. Association recommends that on all freight-cars which are not equipped with ladders (such as flat-cars) two hand-holes should be attached to each end-sill.

Hand-holds on end-sills should have at least 2 inches clearance behind them, and all other hand-holds should have at least 2½ inches clearance behind them.

All hand-holds should be made of iron not less than ½-inch diameter; hand-holds on sides and ends of cars should be at least 2 feet long in the clear; those on end-sills to be made shorter only when it is impossible to use this length.

Hand-holds are sometimes distinguished by their location as *roof*, *ladder*, *end-sill*, etc., hand-holds.

Hand-hole. See *Dust hand-hole*. *Fare-wicket*.

Handle. "That part of anything by which it is held in the hand. A haft. As the handle of a knife or other instrument."—*Worcester*. They are designated by the name of the part or thing to which they are a handle, as *Ash-pit door-handle*, etc.

A *grab-iron* is often called a handle, and was so named in the last edition of this dictionary, but *grab-iron* and *hand-hold* are more common, and the part is not properly a *handle*, which means in general that part by which an object is held and moved about or controlled.

Handle spring (engineer's brake-valve). 39, figs. 1710-15. A spring carrying a dog to hold the handle in any desired position.

Hand-pole. (Street and suburban cars.) 185, figs. 5654-67. A pole carried on *Hand-pole brackets*, bolted to the *Deck-sill*, on which pole are hung *Hand-pole straps*, for people who are required to stand to cling to and avoid falling. See *Pole-straps*.

Hand-rail. 1. A bar or rail to take hold of with the hand; as the *body hand-rail* of passenger-car platforms, *door hand-rail*, *inside hand-rail*, and *step hand-rail* of street-cars, and *roof hand-rail* or *brake hand-rail* of box and stock cars, 190, figs. 229-31, all of which see.

2. (Tank cars.) 121, figs. 374-6. An iron pipe supported on *hand-rail posts* on the outside of the running board, for trainmen to hold on to in passing over cars.

Hand-rail bracket (postal cars). Figs. 3624-5. See also *Inside hand-rail bracket* (street-cars, etc.).

Hand-rail brace (freight-car roofs). 190, figs. 229-31. See *Roof hand-rail*.

Hand-rail post (tank car). 122, figs. 374-6.

Hand-wheel (for slewing gear of pile-driver car). 48, figs. 401-4. See *Slewing-gear*.

Hand-wrecking or derrick-car. Figs. 392-3. See *Wrecking-car*.

Hand-straps (street and suburban cars). Figs. 3630-3. Straps attached to the inside hand-rail for passengers to hold on by. Generally made in the form of a double loop.

Hand-wheel. A *brake-wheel*, which see.

Hanger. 1. "That by which a thing is suspended."—*Webster*.

2. "A means for supporting shafting of machinery."—*Knight*.

See <i>Bell-cord hanger.</i>	<i>Push-rod hanger.</i>
<i>Berth curtain-rod hanger</i>	<i>Rocker-bearing-timber hanger.</i>
<i>Brake-beam adjusting hanger.</i>	<i>Safety-hanger.</i>
<i>Brake-hanger.</i>	<i>Spring-hanger.</i>
<i>Door-hanger.</i>	<i>Step-hanger.</i>
<i>Link-hanger.</i>	<i>Strap-hanger.</i>
<i>Parallel brake-hanger.</i>	<i>Swing-hanger.</i>
	<i>Swing-link hanger.</i>
	<i>T-hanger.</i>

Hanger-link. A *swing-hanger*, which see.

Hanging-boards, or meat-timbers (refrigerator-car). Fig. 596. Transverse bars resting usually on *bogus plates*, to which the load of meat is suspended.

Hanging-door sheave. Figs. 2825-42. See *Car-door hanger*.

Hanrahan system of refrigeration. Figs. 10, 274-7.

Hartshorn shade-roller. Figs. 4564-6. See *Shade-roller*. An ingenious device to hold window-shades at any desired point by means of *centrifugal pawls* which fly out and do not check the revolution of the roller while in rapid motion, but engage with and hold it at any point

otherwise. The *McKay* shade-roller is somewhat similar, but uses a cam instead of a pawl.

Harvey steel car-truck. Figs. 4576-7. An all-steel car-truck made by the Harvey Steel-Car & Repair Works, of Harvey, Ill. The same company has designed and built box, gondola, stock, and other cars entirely of steel, but they have not as yet been received with much favor nor confidence. Specific faults or objectionable features are not pointed out, but there seems to be a sentiment or prejudice against the general adoption of steel for car construction. The extra first-cost doubtless has something to do with it.

Hasp (also sometimes termed shackle). Figs. 2741, 2743-4. The bar which fits over a *staple* and is fastened thereon by passing the *shackle* of a padlock through the staple, or by a pin. The other end of the hasp is attached by a pin or another staple to the door. See *Door-hasp*. *Head-board coupling-hasp*.

Hasp-staple. Fig. 2742.

Hard-hair. A quality of curled-hair which is very stiff or rigid. See *Curled-hair*.

Hart deck-sash pivot and ratchet-catch. Fig. 4391-3. A device for regulating the opening of deck-sashes, the special feature of which is the undulating rack, enabling the sash to be easily moved by the hands and yet holding it fixed when released in any one of several different positions.

Hartley parlor-car chair. Figs. 3998-9. One of the varieties of adjustable chairs for railroad use. In its complete form it has three separate adjustments of the foot-rest, the back, and the head-rest. A *rear foot-rest* is also sometimes attached for the benefit of the occupant of the chair in the rear. The adjustments are controlled by a *thumb-lever*, *chair-back latch*, and *adjusting-lever*.

Hatfield hanging-door sheave. Fig. 2829. See *Car-door hanger*.

Hat-hook. Figs. 3673-80, etc. A metal hook for hanging hats on.

Hat-post. Figs. 3666-72, etc. An upright metal pin for hanging hats on. These are used chiefly in sleeping and parlor cars, and they are invariably combined with a hook and technically called *Hat-post and hook*.

Hat-rack. A *basket-rack*, which see.

Hay-car. A box-car for carrying baled hay; usually made with larger bodies and doors than ordinary box freight cars.

Head.

See <i>Cylinder-head.</i>	<i>Draw-head.</i>
<i>Brake-head.</i>	<i>Drawbar head.</i>
<i>Buffer-head.</i>	<i>Piston-head.</i>
<i>Cross-head.</i>	<i>Tank-head.</i>
<i>Dome-head.</i>	

Head-block. 1. (Of a derrick or crane.) 20, figs. 392-3. The casting carried at the top of the *mast* to which the boom-shoe rods, tension-rods, and guy-rings, etc., are attached. It usually revolves upon a *head-block pin*.

2. (Of a switch.) The long timber to which the switch-stand or its equivalent is fastened, and on which the ends of the switch-rails bear.

Head-board. 9, figs. 2409-12. A light partition which separates one berth in a sleeping-car from that next to it. It is stowed away by day in the pocket between the upper berth, when closed up, and the roof. It is secured in place at the back and front by *head-board bolts* entering at the back into a *bushing*, fixed to the top of the stationary seat-back, and along the upper inside edge by a *head-board coupling*, entering into a *head-board coupling-keeper*. The head-board bolt for the front corner of the head-board is of peculiar construction designed to avoid all interruption of a flush surface by day, while still giving a secure attachment.

Head-board bolt. Figs. 4159-60, 4164, etc. 54, figs. 2409-12. See above.

Head-board-bolt bushing. Figs. 4170-1. See above.

Head-board catch. Fig. 4166.

Head-board coupling. Figs. 4157-8. A metal *hasp* and *keeper* by which a head-board is fastened to the side of the car.

The titles to figs. 417-3 are misplaced. Fig. 4157 should read "Head-board-coupling keeper," and fig. 4158 "Head-board-coupling hasp."

Head-board-coupling hasp. See above.

Head-board-coupling keeper. Fig. 4158. See above.

Head-board fastener. Figs. 4174-5, 4180.

Head-board lug. Fig. 4167. Serves same purpose as a *bushing*, which see.

Head-board pocket. 32, figs. 2409-12. A pocket which closes up flush with the head-board surface, but opens at night, by releasing a *head-board rack-catch* so as to afford a receptacle for clothing or parcels. This form of *head-board pocket* has been superseded by a pocket made by folding up the upholstered head-rest as shown in fig. 2412, 32.

Head-board-rack catch and keeper. Fig. 4165.

Head-casting (of a derrick or crane). A large casting placed at the upper end of the *boom* in certain forms of derricks.

Headlight burner. Figs. 3388-9. A burner of extra capacity for locomotive headlights.

Head-lining. A painted canvas or prepared lining with which the ceilings of passenger-cars are covered. The painting on head-linings is intended to be of an ornamental character. When of wood the head-lining is called *ceiling*. The duck for head-lining comes in any width up to 12 feet. Head-lining is sometimes cut up into panels, but a *paneled ceiling* is usually understood to be a wood ceiling, which is largely supplanting canvas head-linings.

Head-lining nail. A nail with a large button-shaped head especially made for fastening head-linings to the ceilings of cars.

Head-piece (street-cars). 148, figs. 5654-67. A *body end-plate*.

Head-rest. 1. (Hartley chair.) See *Head-rest carrier*.

2. 199, figs. 501-4; 32, figs. 2409-12. In a first-class carriage and sleeping-cars a fixed vertical projection from the back of the seat, thickly padded with horse-hair and covered with broadcloth or leather. It serves to support the side or back of the head of a passenger. That at the end of the seat is a head-rest, but it is also called a *seat-head end* or *end-head rest*, 14, figs. 2409-12.

Head-rest carrier (Hartley chair). 10, figs. 3998-9. Arms pivoted to the upper portion of the back frame and carrying the *head-rest*. Their position is regulated by a *thumb-lever* at the side of the chair.

Head-roll (of a seat). Figs. 3901, 3918, 3922, etc. A padded projection at the top of a seat or chair back, which is to support the head. It is cylindrical and extends full width of the seat.

Head-room (sleeping-car berths). E, D, fig. 2408.

Headstock (English). 2, figs. 348-51, 501-4. American equivalent, *end-sill*. The transverse end member of the *underframe*, which see. It is pierced transversely in the center for the drawgear, and the buffing-gear is carried near the ends.

Headstock and diagonal-knee (English). 83, fig. 501-4. A wrought-iron knee connecting the *headstock* to the *diagonal* and the *sole-bar*, and thus binding three of the four main members of the *underframe* together.

Headstock-cap (English). 13, figs. 501-4. A *cast-iron* cap fitting the end of the headstock in order to prevent its splitting, and to prevent any access of water to the end grain of the wood. A wrought-iron strap is sometimes used.

Heat and light tender. A special car coupled in a train carrying a steam generating plant by which the cars are heated, and an electric light plant for lighting the train.

Heater. 1. Figs. 2865-3060. Any apparatus for warming a car, room, or building by convection; that is, by convey-

ing hot water, steam, or warmed air into or through the apartments. The term generally refers to any arrangement for warming apartments other than stoves, which heat by direct radiation. There have been many varieties in use, but the one remaining and which has the field practically to itself is the Baker heater. There are numerous heating systems, but they, for the most part, use Baker heaters in connection with their apparatus. Nearly all the systems use heaters which circulate hot water. They are usually placed in a small closet called the *heater-room*, which see. In emigrant-cars *cook-stoves* are used for heating. The *ranges* of dining-cars, although used for cooking purposes only, are shown in connection with the heaters.

2. (For lamps or lanterns.) A metallic attachment passing around and above the flame (fig. 3397) or otherwise immediately adjacent to it, by which heat is conveyed to the oil in the reservoir below, to prevent freezing, or, in some cases, to assist combustion by heating or volatilizing the oil.

Heater-car. One constructed for the carrying of fruits, vegetables, and other perishable products in winter. They are heated by special forms of mineral oil lamps, the supply to which is automatically controlled by the expansion and contraction of metallic rods. They are principally in use for the transportation of potatoes and other vegetables.

Heater-room. 128, fig. 448. A small closet, cased with sheet metal interior *heat-guards*, to contain the heater and prevent all direct radiation. All heaters proper are placed in some equivalent for such rooms.

Heater-pipe casing. L, figs. 2996-3001; O, fig. 540. A wooden or iron shelf over a heater-pipe in a passenger-car to prevent the feet of passengers from coming in contact with the hot pipes. The casing also forms a foot-rest.

Heater-plate (of oil lamp). Fig. 3386. A device to conduct the heat of the flame downward so as to keep the oil from congealing. See also fig. 3397.

Heat-guard. A sheet-metal covering for the woodwork of a passenger-car, to protect it from the heat of a stove. It is nailed to the side and ends of the car, and sometimes surrounds the stove, as the conical Russia-iron heat-guard of the Baker heater.

Heating-burner (Minot). Fig. 3397. See *Heater-plate*.

Heel (of shackle of paddock). D, figs. 2771-2. The inner point of the *shackle*, which see.

Height of drawbar. See *Drawbar*.

Helper. A term used to designate either an assistant engine for trains, or a horse to help street-cars up grades.

Helper-ring (street-cars). An iron ring fastened to the platform end-timber to attach an extra horse to pull up steep grades.

"**Hercules**" bearing. One of the forms of so-called *Babbitt metal bearings*, which see.

Hewitt journal-box lid. Figs. 5170-1; and in fig. 4579. An invention, patented June 19, 1877, which consists in adding grooved lugs or ears on the outside edges of a journal-box, in which the lid slides, but is prevented from escaping, after the truck has been put together, by striking against the arch bars or wheel-piece of the truck. It has been very largely used. It has several features, by reason of which it is being abandoned. It is being superseded by the M. C. B. lid.

Hibbard spring. Fig. 5254. A spiral spring composed of several coils of steel of rectangular section. The coils are placed inside of each other and are made of different diameters and wound in opposite directions, or "right and left."

High-back seat. Figs. 92, 3911, 3919, 3952, 3968-72, etc. A class of seats lately introduced with extra high back and frequently a *head-roll* or *head-rest*.

High-sided wagon (English). A four-wheeled gondola car, with sides about 4 feet high. Resembles wagon

shown in figs. 348-51, except that the sides are higher. Used chiefly for bulky freight, wheat, potatoes, sacks and bales. See *Wagon*.

Hinge. Figs. 2586-2620. "A hook or joint on which a door, gate, etc., turns."—*Webster*. They are provided with a tube-like *knuckle* through which the *hinge-pin*, which see, passes.

See <i>Ball-bearing butt hinge.</i>	<i>Man-hole hinge.</i>
<i>Door-hinge.</i>	<i>Seat-hinge.</i>
<i>Double-acting hinge.</i>	<i>Sofa-hinge.</i>
<i>Drop-door hinge.</i>	<i>Stop-bar hinge.</i>

The common door-hinge is usually a *butt* or *butt-hinge*, the varieties of which are the *acorn-butt*, a large ornamental hinge, *Blake-butt*, which see, and the *hopper-butt*, so called from its pointed form. The *parliament hinge* is a sort of T-shaped butt-hinge to afford more room for screws. It is little used except for ornamental purposes. The *strap-hinge* is a common form of rough hinge for heavy doors, but it is sometimes made very elaborate and ornamental, figs. 2603-4. A T-hinge is a combination of the butt and strap-hinge, one-half being of each form. Butt-hinges are either *fast-joint*, *loose-joint* or *loose-pin*. A *double-acting* hinge is one which permits the door to swing either way. *Berth-hinges*, figs. 4183-93 are also loose or fast-joint. *Sofa-hinges*, figs. 4126-7, and *seat-hinges*, fig. 4111, are used in sleeping cars to connect the seat and seat-back.

Hinge-burner (mineral-oil lamp). Figs. 3373-4. A burner of which the chimney-seat is hinged to the lamp-top so as to give access to the wick. They are in decreasing use.

Hinged-sash bar (street cars). 193, figs. 5654-67.

Hinge-pin. Figs. 2588, 2599, etc. The pin passing through the knuckle of a hinge and holding the two parts together. A *loose-joint* butt-hinge has the pin fast in the lower half of the knuckle and projecting upward, so that the other half is held on only by gravity. The hinge-pin in the best hinges, screws into the knuckle.

Hinkley brake-slack adjuster. Figs. 1761-8. A device consisting of a screw working in a swiveled sleeve actuated by a ratchet-wheel and pawl. When the rod to which it is attached travels as it must when the brakes are applied the screw is turned so as to take up the slack and if it be more than a certain amount, the pawl engages in the next tooth when the rod returns in its movement to release the brakes.

Hinge-plate washer (English). 73, figs. 348-51. A long wrought-iron washer taking all the bolts securing the main part of the hinge to the door.

Hinson car-coupler. Figs. 2150-60.

Hitchcock chair. Figs. 3996-7. A revolving and reclining chair with leg and foot rests, somewhat after the style of the *Hartley* and *Horton* chairs.

Hitchcock combination hot-and-cold-water faucet. Fig. 3494.

Hix drop-lock. Freight-car doors. Figs. 2756-7.

Hodge brake. Figs. 1463, 1465, 1538, 1693-8. An arrangement invented by Nehemiah Hodge, patented 1849, for operating the brakes on each truck of a car simultaneously, and equalizing the pressure on all the wheels. The brake may have either one or two levers on each truck. Underneath the car-body are two levers called *Hodge* or *floating levers*, with movable fulcrums in their centers, which are connected together by a rod. One end of each of these levers is connected by a rod and chain to the brake-shaft, and the other end of the floating lever is connected by a rod with the long arm of a brake-lever on a truck.

Hodge lever. 12, fig. 1693-8. See above. The Hodge brake-gear is used altogether with the Westinghouse air brake apparatus.

Hodge lever-guide. See *Floating lever-guide*.

Hog-chain ("Shipbuilding.") A chain in the nature of a tension-rod passing from stem to stern of a vessel, and

over posts nearer amidships; designed to prevent the vessel from drooping at the ends."—*Knight*.

Hence applied to certain forms of trusses in car construction, as in the pile-driver car, 36, figs. 401-4, and in fig. 400. A hog-chain is an *inverted* truss-rod, and usually so called when applied in connection with and in similar form to a body truss-rod, as in fig. 512, and 220, fig. 505, the object of a truss-rod being to prevent a beam from sinking in the middle, and of a hog-chain to prevent sinking at the ends when supported at the middle. Also called an *overhang truss rod*.

Hog-chain queen-post. 221, fig. 505. See above.

The struts over which the *hog-chain* passes.

Hog-chain rod (of a passenger-car). 167, fig. 456. See above. More properly a *continuous counterbrace-rod* or an *overhang truss-rod*.

Hoisting-block (of a derrick or crane). 2, figs. 389-96.

The main block at the lower end of the *hoisting-chains* carrying the *sheave-hook*, or *hoisting-hook*, to which the load is attached.

Hoisting-block clevis. A clevis carried at the top of a hoisting-block to which the fixed end of the hoisting-chain is attached. In some cases, as in L, figs. 151-3, it is attached to a clevis at the upper end of the boom.

Hoisting-chain (of a derrick or crane). 5, figs. 389-96.

The chain attached to the hoisting-drum at one end and to the hoisting-block or boom-clevis at the other, by which the loads are raised.

Hoisting-chain sheave. 21, figs. 389-96. A pulley placed in some wrecking-cars at the foot of the mast, when the hoisting-gear is at some distance from it. The term is equally applicable to the *mast-sheave* and *boom-sheave* at the top of those parts of a derrick, but the latter are generally otherwise distinguished.

Hoisting-hook. See *Sheave-hook*. See also *Hoisting-block*.

Holder. "Something by which a thing is held."—*Webster*.

A great variety of parts which serve this purpose are so called, as *door-holder*, *lamp-holder*, etc., which take their names from the thing which they hold.

Hollow piston-rod. (Westinghouse freight and tender brakes.) A brake-cylinder piston-rod which is hollow to receive the *push-rod* or *push-bar*, which see.

Hollow spoke-wheel. Figs. 5332, 5351-2. See *Car-wheel* and *wheel*.

Hood. 1. See *Platform-hood*. *Ventilator-hood*. A *roof-apron* which is attached to both *platform-roofs* and *platform-hoods* is sometimes called a hood.

2. (Spear-heater.) Figs. 3058-60. More properly a *ventilator* or *wind-scoop*. A horizontal tube or covering on the outside of a car, and on top of the cold-air pipe, so as to give the latter a T-shape. The air is admitted to the pipe through the ends of the hood, which are covered with wire-netting to exclude cinders. It has a valve which is moved by the current of air so as to admit it whichever way the car runs.

3. (For urinal.) Figs. 3874-5. More properly *ventilator-cap*.

Hood-support (street-cars, etc.). 83, figs. 5654-6. A *platform end-post*.

Hook. See

<i>Bell-cord end-hook.</i>	<i>Draw-hook.</i>
<i>Berth-catch hook.</i>	<i>Hat-hook.</i>
<i>Berth-curtain hook.</i>	<i>Hat-post and hook.</i>
<i>Body check-chain hook.</i>	<i>Pouch-hook.</i>
<i>Check-chain hook.</i>	<i>Lamp-case hook.</i>
<i>Coat-and-hat hook.</i>	<i>Seat-hook.</i>
<i>Coat-hook.</i>	<i>Stake-hook.</i>
<i>Coupling-hook.</i>	<i>Table-hook.</i>
<i>Door-hook.</i>	<i>Table-leg hook.</i>
<i>Door-latch hook.</i>	<i>Truck check-chain hook.</i>
<i>Drawbar coupling-hook.</i>	<i>Window-curtain hook.</i>

Hooked brake-head. Fig. 1614-15.

Hoop (for oil-lamps). Figs. 3393. A ferrule with an interior thread into which the burner screws.

Hoopstick (English). See *Roofstick*.

- Hopkins' journal-bearing.** A *lead-lined journal bearings*, which see, which use a *thin* coating of lead inside an ordinary brass-bearing.
- Hopper.** 1. (Passenger-cars.) Figs. 3855-68. A *closet-hopper*, or *soil-hopper*.
2. (Freight-cars.) See *Hopper bottom-car*.
- Hopper-bottom car.** Fig. 24-26; also figs. 305-320, 324a. A car with an inclined bottom sloping from every side (or simply from the ends), to *drop-doors* in the center, so that the entire contents can be discharged. They are chiefly used for carrying coal, but sometimes other minerals. New hopper-bottom cars are chiefly eight-wheeled hopper-bottom cars, though many old four-wheeled hopper-bottom cars are still in service. *Hopper-bottom gondola-cars*, figs. 24-26, etc., have a similar bottom in their center, and those shown in figs. 305-9 are designed to completely discharge their contents without assistance. The four-wheeled hopper-bottom cars are being superseded by eight-wheeled gondola cars with single or twin hoppers. Hoppers are distinguished as *box-hoppers*, those whose sides slope from the ends only, and as *pyramidal*, or those whose sides slope from the sides and ends. A *hopper-bottom* car should be distinguished from a *drop-bottom*. The latter not being provided with a hopper. See *Gondola-car*.
- Hopper butt-hinge.** Figs. 2601, 2616. A hinge so named from its pointed form.
- Hopper carry-irons.** Figs. 1076-9. A *hopper-supporting strap*, which see.
- Hopper-chain.** See *Drop-door chain*.
- Hopper-plates.** The sheets of iron constituting the bottom of a hopper-bottom coal-car. When this part is of wood it is termed the *inclined floor*.
- Hopper siding.** 28, fig. 324a. The planking that forms the side of a *box-hopper*.
- Hopper stayrods.** 71, 71a, figs. 305-15. Inclined rods passing through the center sill and to the *hopper supporting-strap* at the hinged end of the doors to prevent the hopper from sagging in the middle.
- Hopper supporting-strap.** 72, 73, figs. 305-15. A heavy U-shaped iron strap bent to the shape of the hopper of a gondola car, and the ends bolted to the side sills. Its office is to support the hopper, and it is usually applied at the end of the inclined floor, and in the middle of the hopper at which point the doors are hinged.
- Hopper ventilator.** Figs. 3841-2. See *Bell's exhaust hopper ventilator*.
- Horizontal brake-shaft.** 95, figs. 232-43. A brake-shaft usually at the end of a car-body, whose position is horizontal instead of vertical, so that it can be applied from below. When used it is commonly in combination with a long brake-shaft of the ordinary kind at the other end of the car. It is for use in grain elevators, tunnels and in city yards, and chiefly on the Pennsylvania Railroad.
- Horizontal brake-shaft chain.** 104, figs. 232-43. A chain attached to a brake-rod at the end of a car and running over a pulley to a horizontal shaft on which it is wound.
- Horizontal equalizing-lever.** 27, figs. 2437-45. Pullman Vestibule. See *Equalizer*.
- Horizontal telegraph-cock, or faucet.** Fig. 3489-90. See *Faucet*.
- Horn.** (Janney coupler.) 49, fig. 2440. A part rigidly fastened to the coupler or drawbar, by means of which the coupler and buffer springs are connected. See *Pedestal-horn*.
- Horn-bolt.** (Janney coupler.) The bolt securing the horn in place.
- Hornplate** (English). The name given to the part of a locomotive or tender which on other railroad vehicles is termed *axle-guard* (American, *pedestal*), which see.
- Horse box** (English). A four-wheeled covered vehicle adapted to run on passenger trains. It is fitted with large side-doors and mangers, and is divided into three stalls by movable padded partitions. See also *Racehorse box*.
- Horse-car.** 1. Figs. 42-7. A box-car fitted up especially for carrying horses, by leaving certain slatted openings, etc. They are then classed under the general name of *box-stock* car. Some horse-cars are very elaborate.
2. Fig. 5652. *Street-cars*, which see, drawn by horses, are very frequently called horse-cars.
- Horse-hook, or towing-hook** (English). 81, figs. 348-51. Nearest American equivalent, *roping-staple*. An iron hook attached to the sole-bar and forming an attachment for a rope by which the vehicle can be drawn. Horses are largely used for switching in England.
- Horse shoe-seal.** Figs. 3890-a, 3877-8. A cast-in wire and lead seal.
- Hose.** Flexible tubing, made of leather, canvas, or india-rubber, for conveying water, air, or other fluids. It is sometimes *armored*, which see. See also *Brake-hose*. *Coupling-hose*. *Tender-hose*.
- Hose-couplings.** See *Brake-hose couplings*.
- Hose-clamp.** Fig. 1742. A clamp to bind the hose to the *hose-nipple* and *coupling*.
- Hose-nipple.** Fig. 1739. Its use is shown in figs. 1737-8.
- Hot-air box** (Spear-heaters). A box, called also the *running-pipe* or *hot-air pipe*, passing along the sides of the car under the seats with a register adjacent to each seat and connecting with the air space around the stove, so as to deliver hot air through the car. See *Ventilator*.
- Hotel-car.** A sleeping-car with a kitchen for cooking and arrangements for serving meals. *Dining-cars* have kitchens, etc., but no sleeping-berths. Hotel-cars have passed out of use, in favor of dining-cars, with sleeping cars attached.
- Hotel-car range.** See *Range*.
- Hot-water heater.** See *Baker-heaters*.
- Hot-water pipes.** P, figs. 2452-3a. Pipes running alongside of a car and under the seats, which contain hot water, and by which the car is heated. They are usually naked iron pipes, and the car is heated by convection as well as radiation. Between the seats the pipes on the side of the car have a *hot-water guard-rail* running along over and above them.
- House-car.** An occasional term for a *box-car*, which see.
- House of the drawbar.** Figs. 1936-2020, 2021. See *Drawbar*.
- Housing-box.** A *journal-box*, which see.
- Howard lock** (freight-car door). "Q. & C." Co. Figs. 2752-5.
- Howard's parlor-car water-closet.** Figs. 3838-40. A device, the essential feature of which is the connection between the seat-lid and the pan and service measure, by which no water is carried to the pan except on opening the lid. See *Parlor-car water-closet*.
- Howard safety berth-latch.** See *Safety berth-latch*. The *Dayton* is another kind. The two differ very slightly.
- Hub** (of a car-wheel). The central portion into which the axle is fitted. It is usually cylindrical in form, and projects beyond the disks or spokes of the wheel on each side. In England termed the *boss*.
- Hub-bolts** (steel-tired wheels, which see). Figs. 5308-13. Bolts fastening the *face-plates* to the *hub*.
- Hurricane-lamp** (another name for *tornado-lamps*, which see). Figs. 3261-2 are hurricane or tornado-lamps.
- Hutchins freight-car roof.** Fig. 2396. A form of roof consisting of two layers of boards, 6 inches wide and matched, and separated by a continuous sheet of Hutchins three-ply plastic roofing. See *Car-roof*.
- Hyatt-elastic roller-bearing.** Figs. 5682-3. A bearing the rollers of which are of flat bar steel wound spirally like a close spiral spring, which gives flexibility to the roller. By virtue of this flexibility it is claimed that they adapt themselves to inequalities of the axle and box-lining and do not jam and wedge. The rollers are said to yield and distribute the load over several of their

number, thus reducing the pressure upon the top roller. The rollers are kept parallel by a frame carrying parallel pins or rods on which the spiral-rollers revolve loosely. Wrought iron axles are fitted with a steel sleeve, and the cast boxes are lined with a steel bushing. The boxes have dust-guards and are made narrow enough to fit in existing car-trucks of steam and electric roads.

Hydraulic jack. Figs. 3728-52. A tool or machine in which the power is exerted by means of the pressure of some liquid acting against a piston or plunger, for raising heavy weights, like a car. The head and interior tube or ram, fig. 3734, forms a reservoir from which the fluid flows to the pump, and to which it is returned in lowering. From the pump it is forced, by the downward stroke of the piston, past the lower valve into the cylinder, and, this being closed at the bottom, the ram rises. The lever, which is made with a projection on one edge, slips into a socket at the side of the head. This socket passes through an arm on the interior of the head, and to this is fastened the piston of the pump. The claw attachment, figs. 3729, 3734, is a third tube, which screws into the head, below the ram-collar and outside of the cylinder, at the lower end of which is a claw projecting out at one side. They are rated so that one man can raise the weight for which they are designed. The speed of lifting is inversely proportionate to the amount lifted. Ten tons can be lifted one foot in about a minute and a half. See *Dudgeons hydraulic-jacks*, and *Watson and Stillmans hydraulic-jacks*.

Hydraulic-pressed car-candles. Candles made of paraffin by hydraulic pressure. See *Candles*.

Hydrostatic-buffer. A platform and buffing apparatus designed by Mr. A. G. Leonard and first applied to the Empire State Express between New York and Chicago. It consists of a buffer plate extending the full width of the *platform end-sills*, with *two side, two intermediate, and one center buffer stems*. These center stems are backed up by springs as is usual in other buffing apparatus, and in addition the center and side stems are enlarged at their ends and fitted so as to act as pistons in buffer-stem cylinders. The two side and center cylinders are filled with a liquid and they are connected with suitable piping. The drawbar has attached to it a pressure-bar which is also fitted to a cylinder which has pipe connection with the center and side buffer stems. The effect of this arrangement is to equalize the pressure upon the buffer-plate. If one side-buffer stem receives more than its proportion of the thrust, the fluid conveys the hydrostatic pressure to the other side and center, and tends to equalize it. When the drawbar is drawn out the *pressure-bar piston* forces the fluid from its cylinder into the *buffer stem cylinders* and forces out the *buffer-plate*, insuring contact at all times between the buffer-plates. Folding steps are required, since the buffing apparatus takes up the full width of the platform.

I-beam. A general term applied by makers to any form of rolled iron having an I cross-section. The top and bottom parts are termed the *flanges* and the middle the *web*. The usual dimensions are given by the total height from out to out, and vary from three to fifteen inches. When one of the flanges is simply a round bar it is termed a *deck-beam*. I-beams are used in car construction, with channel-bars and also for trucks. I-beams are used for *center and intermediate sills*, also for truck-bolsters, as in figs. 4576, 4644-66; channel-beams for side-sills, truck-transoms, figs. 4729, etc., for plating truck bolster, figs. 4738-9, and for spring-planks, 4580, 4644, 1748, etc.

Ice-car. A car for transporting ice, usually constructed with double roofs, floors and sides, filled in with sawdust or other non-conducting substance.

Ice-pan (refrigerator-cars). The receptacle for carrying ice, especially roof ice-pans, in distinction from *ice-racks* at the ends of the car.

Igniter, or signal-holder (for blue-light signals). A wooden handle having a piston in the end for igniting the blue-light by compression.

Inclined floor (coal-cars). 27h, figs. 305-9; 27a, figs. 310-15. Subdivided into *inclined end-floor* and *inclined side-floor*, the latter not always used.

Inclined floor cross-bar (hopper-bottom coal-car). Cross-bars passing from one sill to the other, in the modern cars usually of iron, supporting the inclined hopper-plates, or wood floor.

Inclined floor-timbers (coal-car). The wooden sills to which the inclined floor of a coal-car is nailed.

Inclined-plane car. A passenger street-car which is drawn by a wire rope on a steep inclined plane. The car is so arranged that the floor will be level when the wheels are on the incline, by making the wheels at one end larger than at the other, or by raising up one end of the car-body.

Inclined side-floor (coal-car). See *Inclined floor*.

India-rubber body-cushion, or Attock's body-block. (English.) 186, figs. 501-4. A piece of rubber about 6 in. by 3 in. by 1 in. thick, interposed between the body and the underframe, serving to deaden noise and vibration and permit a free circulation of air to the floor timbers.

India-rubber. A gum which exudes from a tropical tree growing in the East and West Indies, Mexico, South America, etc. It is prepared for use by *vulcanizing* with a greater or less proportion of sulphur, according to the stiffness required.

India-rubber car-spring. A spring consisting of a cylindrical block of india-rubber. Such springs have been used both for carrying the weight of cars and for buffer and draw-springs. Now rarely used in this country, but largely in Europe.

India-rubber floor-mat. Figs. 2856-7. See *Floor-mat*. They are either *perforated* or *corrugated*.

Ingate. "The aperture in a casting-mold at which the melted metal enters."—*Knight*. Often called a *gate*.

Injector. Figs. 4327-9a. A large hood or wind-scoop on the roof of the car to catch the air and force it through the various pipes into the car. Corresponding parts are called *hoods, jacks, ventilators, ventilator-jacks, wind scoops*, etc.

Inner centre-stem guide. Figs. 1424-5. 43, figs. 2296-2300. See *Buffer stem-guides*.

Inner-coil (graduated bolster-spring). See *Spiral spring*.

Inner draw-bar carry-iron (Miller coupler). 32, figs. 2290-2. A U-shaped strap of wrought-iron bolted to the suspender beam to support the drawbar coupling-hook.

Inner face-plate. Fig. 2432, and 4, fig. 2435. Also called a *back face-plate*. See *Gould vestibule*.

Inner hung-brake. Figs. 1530-1, 4580-2, 4644-8, etc. When the break-shoes and beams are *between* the wheels. Figs. 4740-2. When attached on the outside, it is an *outer hung-brake*.

Inner intermediate-sills. Figs. 229-66. Those two intermediate-sills next to the center-sills. See *Outer intermediate-sills*.

Inner lamp-ring (English). 168, fig. 501. An ornamental or wooden ring in the inner surface of the roof surrounding the aperture for the *roof-lamp*, which see.

Inner side-stem guide. Figs. 1416-18, 36-37, figs. 2296-2300. See *Buffer stem-guides*.

Inside body-corner knee (English). 76, figs. 348-51. American equivalent, *sill knee-iron* or *corner plate*, which latter is used outside instead of inside. A wrought-iron knee placed in a horizontal plane securing the end and side of the body together.

Inside-casing (Baker heater). Figs. 2901, 2916. Sheet-iron, or steel-plate, bent and riveted into the shape of a frustum of a cone which forms the top of the fire-pot.

Inside casing. (English.) 129, figs. 501-4. Boards in

the inside of the body attached to the framing of the sides and ends. Also called *inside-lining*.

Inside-cornice (passenger-car interiors). 94, figs. 435-73, 539-41. A molding which fills the angle where the roof joins the side of the car.

Inside-cornice fascia-board. 95, figs. 435-541. A projecting board which forms a molding or ornament under the *inside-cornice*. The *sub-fascia board* lies under it. The arrangement of these details, however, is frequently varied.

Inside-cornice sub-fascia board. 96, figs. 542-67. See above.

Inside end-piece (of truck-frame). Figs. 4836-40. The end-piece which is nearest to the center of the car. It is usually straight while the outer one is curved so as to make room for the draft-rigging.

Inside frieze-panel (street-cars). A panel on the inside over a window.

Inside hand-rail (street-cars). 185, figs. 5654-67. A rail, usually made of wood, attached to the rafters by metal brackets, and carrying leather straps in the form of loops for passengers to hold fast to.

Inside hand-rail bracket. 187, figs. 5654-67 and figs. 3626-70. See above.

Inside-lining. 1. 53, figs. 229-66, etc. The boarding which is nailed to the insides of the posts of freight, baggage and other cars. In box-cars it extends half way up only, to the *girth*. *Inside-lining* becomes sometimes *inside-sheathing* when it is carried up to the roof, and is the only sheathing for the car, the frame being left exposed.

2. (English.) See *Inside-casing*.

Inside-lining cap. A *girth* or *belt-rail*, which see. See also above.

Inside-lining stud. A stud extending from the side-sill to the girth to serve as a "nailer" for the inside-lining.

Inside-shell (Kirby's car-door lock). H, fig. 2628. A kind of escutcheon on the inside face of the door inclosing the *latch-pull* within it.

Inside spring-case. A shell cast on the spring-plates to keep the coils in place.

Inside wheel-piece plate. 12, figs. 4842-4966. See *Wheel-piece*.

Inside window-panel. 89, figs. 539-41, etc. A panel inside of a passenger-car between the windows.

Inside window-sill. 78, figs. 435-73, 539-41, etc. A horizontal piece of wood under the window on the inside.

Inside window-stop. A wooden strip attached to a window-post on the inside of a window-blind or an inner sash of a double window. It forms a groove in which the blind or window-sash slides. Also called *window-casing*. Sometimes the *window-molding* forms a stop on the inside.

Inspection-car. 1. A car used for inspecting track of a railroad. In inspecting the track it is pushed in front of a locomotive.

2. Figs. 5586-7, 5605-8, 5613-16, 5592-4. A hand-car used for very much the same purpose. *Three-wheeled hand-cars* are also used by roadmasters for inspection. See *Hand-car*.

3. Fig. 5612. A small car propelled by steam with seats for 4 to 6 persons.

Inspector's lantern. A general term, commonly meaning some form of bi-colored or tri-colored lantern, with colors changeable at will, usually by means of slides, but sometimes by other devices. See *Burrell signal-lantern*.

Instruction-car. Figs. 218-20. (Air-brake.) A car maintained by the Westinghouse Air-Brake Co. and by some railroads, to send out over the line in charge of experts, and with a full equipment of air-brake apparatus for the purpose of instructing employes required to operate or inspect air-brakes, as to their construction, operation and proper maintenance. The same end is accomplished by some roads by establishing instruction-shops or schools

at certain points along the road and requiring employes to attend the same.

Interchange of traffic (rules for). A code of rules adopted and amended from year to year, by an organization composed of master car-builders and others, who have held their meetings during the session of the Convention of the Master Car-Builders' Association. The rules of 1894 make the following provisions, viz.:

Code of Rules Governing the Condition of, and Repairs to, Freight-Cars for the Interchange of Traffic.

RULE 1. Each railway company shall give to foreign cars, while on its line, the same care as to oiling and packing that it gives to its own cars.

RULE 2. Cars must be delivered in good running order, and returned in as good general condition as when received.

RULE 3. Cars may be refused for any of the following defects:

- (a-r') Defects in wheels. See *Wheels*.
- (n-p) Defects in axles. See *Axles*.
- (s) Defects in brakes. See *Brake-gear*.
- (t) Defects in steps, etc. See *Steps, ladders, etc.*
- (u) Defects in drawbars and attachments. (M. C.-B. Automatic couplers.) See *Drawbars and attachments*.
- (v) Center sills or draft timbers spliced.
- (w) Intermediate or outside sill recently spliced in a manner not prescribed by the Rules.
- (x) Leaky roofs on merchandise or gran cars.
- (y-1) Cars with doors missing; or in condition which will improperly protect the lading, or with door shoes worn or loose so as to allow the door to swing outwardly.
- (y-2) Cars with four-hole center plates and long center pins through bolster, unless two of the bolts are effective.
- (y-3) Cars with four-hole center plates and short center pins which rest in upper plate, unless three of the bolts are effective.
- (y-4) Cars with two-hole center plates, unless both bolts are effective.
- (y-5) Cars with two-hole center plates if center plate is broken.
- (z) Special or general defects of bodies or trucks, which render cars unsafe to run.

RULE 4. A car with defects which do not render it unsafe to run nor unsafe to trainmen must be accepted, but in such cases the company to which the car is offered may require that a defect card shall be securely attached to the car with four tacks, preferably on the outside face of the intermediate-sill between the cross-tie timbers.

Duplicate cards shall be furnished for lost or illegible defect cards.

RULE 5. Defect cards shall be 3½ inches by 8 inches, and of the form shown below. They shall be printed on both sides and shall be filled in on both sides with ink or black indelible pencil. The card must plainly specify in full each item for which charges are authorized.

M. C.-B. DEFECT CARD.	
(Name of Road.)	
Car No.....	Date.....
Initial	Line
Will be received at any point on this company's line with the following defects.	
.....	
.....	
.....	
.....	
Inspector at.....	

Send bill on this card to

NOTE—Fill in defects on both sides with ink or black indelible pencil. Attach this card with four tacks on outside face of intermediate sill, between cross-tie timbers.

RULE 6. Any company finding a car with defect card attached may make the repairs noted by the card, provided such repairs are necessary for the safe running of the car, and render bill for same to the company attaching card,

stating upon the bill the date and place when the repairs were made; the card to accompany the bill as voucher for the work done, but no bill shall be rendered for repairs which have not been made.

Any company finding a car with defect card attached, may make such partial repairs as may be necessary for the safe running of the car. It shall strike the items repaired from the card by drawing two lines in ink through such items on both sides of the card, and replace the card upon the car. It shall notify the company which issued the original card of the items repaired, and the latter company shall issue a defect card covering the partial repairs made, that card to be used as a voucher and to accompany the bill for such partial repairs.

Defects for which owners are responsible:

RULE 7. Locks and grain doors in cars are at owner's risk.

RULE 8. Car owners shall be chargeable with the repairs of their own cars when such repairs are necessitated by:

(a) Roofs lost from cars on account of decayed condition or faulty construction, and owners notified before the repairs are made.

(b) Brake shoes worn out, no charge to be made for labor of renewing; no credit to be allowed for scrap.

(c) Journal bearings needing renewal, no charge to be made for labor of renewing, and an arbitrary scrap credit shall be allowed for one-half the weight of the bearing applied.

(d) Truck or body bolsters, truck transoms, spring planks, or truck springs broken or lost, or arch bars broken or cracked, providing the car was not derailed or wrecked.

(e) Wheels and axles worn out as provided in Rule 9.

(f) Oil box lids lost off when not caused by wreck or breakage due to rough usage.

(g) Brake beams, levers or attachments less than 2½ inches from rail.

(h) Center plate bolts broken or missing.

RULE 9. When wheels or axles are renewed, they shall be treated as follows:

Wheels shall be charged to the company owning the car, if the cause of removal is:

(a) Shelled-out spots. (d) Worn flange.

(b) Seams. (e) Tread worn hollow.

(c) Worn through chill. (f) Burst.

(g) Broken flange, if the breakage is caused by seams worn through chill or worn flange.

(h) Broken rim, if caused by rim being hollow.

(i) Cracked thread, if caused by being worn through chill.

(j) Cracked plate. (l) Broken in pieces.

(k) One or more cracked brackets. (m) Loose.

(n) Out of gage.

Wheels shall not be charged to the company owning the car, if the cause of removal is:

(a) Flat sliding. (b) Chipped flange.

(c) Broken flange, if the breakage is not caused by seams, worn through chill or worn flange.

(d) Broken or chipped rim, not caused by rim being hollow.

(e) Breakage of any kind caused by derailment.

Axles shall be charged to the company owning the car if the cause of removal is:

(a) Wheels having defects which are chargeable to the owners.

(b) Axles bent or broken, or with collars worn off under fair usage.

(c) Axles less than the prescribed limits.

Axles shall not be charged to the company owning the car if the cause of removal is:

(a) Wheels having defects for which the owner is not chargeable.

(b) Axles damaged by derailment or wreck.

(c) Cut journals.

RULE 10. In the case of cars belonging to private parties and corporations other than railway companies, or that are not cared for or controlled by a railroad company, the repairs or renewals of all parts that fail under fair usage, or on account of ordinary wear and tear, or bad or inferior design, may be made by railroad companies, and shall be paid for by the owners, except as already provided in Rule 8.

RULE 11. A car unsafe to load on account of general worn-out condition, due to age or decay, shall be reported to its owner, who must be advised of all existing defects. If the owner elects to have it sent home, he shall furnish two home cards, noting upon them existing defects and the route over which the car is to be returned to its owner. If the route coincides with that over which the car passed to the point where it became unserviceable, no liability shall be incurred as between the owner and the road handling the car, either for freight charges in handling the car or for car service during this movement.

Such cards shall be attached to each side of the body of the car. They shall be 3½ by 8 inches, and of the form shown below. They shall be printed on both sides, and shall be filled in on both sides with ink or black indelible pencil:

FROM	
.....	R. R.
TO	
.....	R. R.
VIA	
.....	
.....	
To be shopped for.....	
.....	
.....	
(Head of Car Department.)	

In case of private line cars, the cars shall be regularly billed home, and the owner notified.

RULE 12. Bills rendered for wheels and axles shall be in accordance with the following schedule of prices for material, with the proper debits and credits:

	NEW.	SECOND-HAND.	SCRAP.
One 36-inch wheel.....	\$10 00	\$7 00	\$4 50
One 33-inch wheel.....	8 50	6 00	4 00
One 30-inch wheel (or less).....	7 00	5 00	3 50
One axle, 60,000 lbs.....	10 00	6 00	4 00
One axle, 40,000 lbs. (or under).....	9 00	5 50	3 50

and with an additional charge of \$1.50 for all labor for each pair of wheels and axle removed from the the truck. If new wheels and axles are substituted for second-hand wheels and axles, proper charges and credits shall be allowed, although such substitution be made on account of only one loose or defective wheel or a defective axle, with the following exceptions: In case the owner of a car removes wheels on account of defective axle, the road responsible for damaging the axle shall not be charged for any difference in value between the wheels used and those removed. In case the owner of a car removes axle on account of defective wheels, the road responsible for damaging the wheels shall not be charged for any difference in value between axle used and that removed.

RULE 22. If the company on whose lines the car is destroyed elects to rebuild, either body or trucks, or both, the original plan of construction must be followed, and the original kind and qualities of materials used. The rebuilding must be completed within 60 days from the original date of damage or destruction. In such cases no allowance shall be made for betterments.

RULE 23. The settlement prices of new eight-wheel cars shall be as follows, with an addition of \$40 for each car equipped with air-brakes. The road destroying a car with air-brakes may elect to return the air-brake apparatus, including all attachments, complete and in good condition.

(See *Freight-car* for the prices of car for several years.)

NOTE.—The lengths of cars mentioned refer to the lengths over-all of the car-bodies, except in the case of flat-cars, in which case the lengths referred to are the lengths over end-sills.

When cars of 60,000 pounds capacity or over and so stenciled have trucks with journals 4 inches or over in diameter when new, \$25 per car shall be added to the figures as given above for the values of car-bodies.

Depreciation due to age shall be estimated at six per cent. per annum upon the yearly depreciated value of the bodies and trucks only; provided, however, that allowances for depreciation shall in no case exceed sixty per cent. of the value new. The amount, \$40, for air-brakes shall not be subject to any depreciation.

Refrigerator-cars, special stock-cars, and other freight-cars designed for special purposes, not specially referred to above, shall be settled for at the present cost price, as may be agreed to by the parties in interest, but the deduction for depreciation due to age shall be on the same basis as for regular freight equipment.

RULE 24. If only the body of a car is destroyed and the company destroying it elects to return the trucks, they shall be put in good order, or accompanied by a defect card and delivered free of freight or other charges to the nearest point on the line of the company operating the car, and the number, line, and class of car destroyed shall be stenciled or painted on each truck so returned.

FURNISHING MATERIAL AND BILLING WORK DONE.

RULE 25. Companies shall promptly furnish to each other upon requisition, and forward free over their own road, material for repairs of their cars injured upon foreign lines that cannot be procured in open market. Requisition for such material shall state that it is for repairs of cars, and shall give the number and lettering of such cars and pattern numbers of castings required when possible.

RULE 26. Bills for work done on defect cards or for material furnished on requisition shall be on the basis of the following charges and credits:

MATERIAL.	CHARGE.	CREDIT.
Cast Iron.....per lb.	\$.01 6-10	5/8c.
Malleable Iron.....	.03 1/2	1 1/2
Bolts, Nuts and forgings.....	.04	1
Steel Castings.....	.06	3/4
Spring Steel (not Springs).....	.05	3/4
Brass and Phos.-Bronze Journal Bearings.....	.13	9
Lumber: Yellow, White and Norway Pine, Poplar, Oak, Hickory and Elm.....per ft.	.03	
Labor.....per hr.	.20	
1 Box or Stock Car Side Door.....appld.	5.00	
1 Box Car Ventilated Side Door, Wooden Frame with Iron Rods.....	8.00	
1 Box or Stock Car Framed End Door.....	3.00	
1 Box or Stock Car Half Side Door.....	3.00	
Chain.....per lb.	.05	1
Air-Brake Hose and Coupling, complete.....appld.	2.00	
1 M. C.-B. Standard Journal Bearing for 4 1/4 inches by 8 inches, Journal to weigh 13 lbs.....	1.69	
1 M. C.-B. Standard Journal Bearing for 3 1/4 inches by 7 inches, Journal to weigh 10 lbs.....	1.30	

M. C.-B couplers or parts of same to be charged at current market prices, which are to be quoted by the secretary September 1 and March 1 of each year. Credits to be allowed at scrap rates as given in above list.

Manufactured articles not included in above list at current market prices without freight charges.

When M. C.-B. couplers are changed in Canada, on defect card acknowledging wrong material, the couplers may be charged at prices fixed in the Rules, plus the customs duty which must be paid on entering Canada.

No percentage to be added for either material or labor.

The following table shows the number of hours which may be charged for labor in doing the various items of work enumerated, which includes all work necessary to complete each item of repairs, except in so far as labor is already included in charges for materials:

	Refrigerator-Cars.		All other Cars.	
	Hrs.	Charge for Labor.	Hrs.	Charge for Labor.
1 side sill replaced.....	44	\$8.80	38	\$7.60
2 " sills.....	65	13.00	53	10.60
1 " sill and 1 inter. sill replaced.....	60	12.00	44	8.80
1 " " " 2 " sills ".....	70	14.00	50	10.00
1 " " " 3 " " ".....	80	16.00	56	11.20
1 " " " 4 " " ".....	90	18.00	62	12.40
2 " sills " 1 " sill ".....	81	16.20	58	11.60
2 " " " 2 " sills ".....	91	18.20	64	12.80
2 " " " 3 " " ".....	101	20.20	70	14.00
2 " " " 4 " " ".....	111	22.20	76	15.20
1 center sill replaced.....	44	8.80	38	7.60
2 " sills.....	65	13.00	53	10.60
1 side sill and 1 center sill replaced.....	65	13.00	53	10.60
1 " " " 2 " sills ".....	86	17.20	68	13.60
2 " sills " 1 " sill ".....	86	17.20	68	13.60
2 " " " 2 " sills ".....	107	21.40	83	16.60
1 intermediate sill replaced.....	40	8.00	29	5.80
2 " sills.....	56	11.20	35	7.00
3 " " ".....	66	13.20	41	8.20
4 " " ".....	76	15.20	47	9.40
1 inter. sill and 1 center sill replaced.....	60	12.00	44	8.80
1 " " " 2 " sills ".....	81	16.20	58	11.60
2 " sills " 1 " sill ".....	70	14.00	50	10.00
2 " " " 2 " sills ".....	80	16.00	64	12.80
3 " " " 1 " sill ".....	90	18.00	56	11.20
3 " " " 2 " sills ".....	101	20.20	70	14.00
4 " " " 1 " sill ".....	90	18.00	62	12.20
4 " " " 2 " sills ".....	111	22.20	76	15.20
1 side, 1 inter. and 1 center sill repl.....	81	16.20	58	11.60
2 " " " 1 " " ".....	102	20.40	74	14.80
1 " " " 2 " " ".....	91	18.20	64	12.80
1 " " " 3 " " ".....	112	22.40	80	16.00
1 " " " 4 " " ".....	101	20.20	70	14.00
2 " " " 1 " " ".....	122	24.40	86	17.20
1 " " " 2 " " ".....	111	22.20	76	15.20
2 " " " 3 " " ".....	132	26.40	92	18.40
1 " " " 4 " " ".....	102	20.40	74	14.80
2 " " " 1 " " ".....	123	24.60	89	17.80
1 " " " 2 " " ".....	112	22.40	80	16.00
1 " " " 3 " " ".....	122	24.40	86	17.20
1 " " " 4 " " ".....	132	26.40	92	18.20
2 " " " 1 " " ".....	133	26.60	95	19.00
2 " " " 2 " " ".....	143	28.60	101	20.20
2 " " " 3 " " ".....	153	30.60	107	21.40
1 side sill spliced.....	15	3.00	12	2.40
1 intermediate sill spliced.....	14	2.80	11	2.20
1 side plate, replaced.....	30	6.00	30	6.00
1 running board, replaced.....	6	1.20	6	1.20
1 end plate, replaced.....	14	2.80	14	2.80
1 " sill under siding, replaced.....	15	3.00	15	3.00
1 " " outside ".....	7	1.40	7	1.40
1 end sill under siding, replaced when one or more defective sills have been replaced.....	3	.60	3	.60
1 end sill outside siding, replaced when one or more defective sills have been replaced.....	2	.40	2	.40
1 end or corner post, replaced.....	5	1.00	3	.60
1 door or side ".....	5	1.00	3	.60
1 platform plank.....	1	.20	1	.20
1 plain metal or wood body bolster, rep.....	10	2.00	8	1.60
1 composite body bolster, replaced.....	12	2.40	10	2.00
1 plain metal or wood body bolster, replaced when one or more defective sills are replaced.....	2	.40	2	.40
1 composite bolster, replaced when one or more defective sills are replaced.....	4	.80	4	.80
1 cross-tie timber, replaced.....	3	.60	3	.60
1 cross-tie timber, replaced when one or more defective sills are repl.....	1	.20	1	.20
1 draft timber, replaced.....	6	1.20	6	1.20
1 draft timber, replaced when its center sill has been replaced.....	1	.20	1	.20
2 draft timbers on same end, replaced.....	10	2.00	10	2.00
1 carlin, replaced.....			2	.40
1 truck bolster, replaced.....	10	2.00	10	2.00
1 spring plank.....	10	2.00	10	2.00
1 truck bolster and 1 spring plank in same truck, replaced.....	12	2.40	12	2.40
1 brake beam, replaced.....	2	.40	2	.40
1 drawbar.....	2	.40	2	.40
1 M. C.-B. knuckle, replaced.....	1/2	.10	1/2	.10
Replacing center plates, 1 or 2 at one end.....	3	.60	3	.60
Replacing center plate bolts in part or all at one end.....	3	.60	3	.60
Replacing draft-timber bolts complete at one end of car.....	3	.60	3	.60
Replacing dead wood at one end of car.....	2	.40	2	.40

An additional charge of \$1 for 5 hours' labor shall be allowed in replacing intermediate or center sills on cars equipped with air-brakes.

MISCELLANEOUS.

RULE 27. In rendering bills, cars shall be treated as belonging to railway companies whose name or initials they bear, except in case of Line Cars, where the equipment list of the general officers of the Line designates a party to make settlement.

RULE 28. For the mutual advantage of railway companies interested, the settlement for a car owned or controlled by a railway company, when damaged or destroyed upon a private track, shall be assumed by the railway company delivering the car upon such track.

RULE 29. Any railway company may become a party to this Code of Rules by giving notice through one of its general officers to the Secretary of the Master Car-Builders' Association.

Any railway company which is a party to this Code of Rules shall be bound by same through its successive revisions, until one of its general officers files with the Secretary of the Master Car-Builders' Association its notification of withdrawal.

Acceptance or rejection of this Code of Rules must be as a whole; and no exception to an individual rule or rules shall be valid.

RULE 30. In order to settle disputes arising under the rules, and to facilitate the revision of the rules at the annual conventions of the association, an Arbitration Committee of five representative members shall be appointed annually by the Executive Committee; three members of this committee to constitute a quorum. The committee shall ask for suggestions of changes, amendments and additions to these rules prior to each annual convention, which it shall consider, and it shall report its recommendations to the succeeding annual convention.

In case of any dispute or question arising under the rules between the subscribers to said rules, the same may be submitted to this committee through the Secretary, who shall, before referring the case to the committee, notify both parties to the dispute to submit their reasons in support of their claims to the committee in order to enable it to decide intelligently. Should one of the parties refuse or fail to furnish the necessary information, the committee shall use its judgment as to whether, with the information furnished, it can properly give its opinion. The decisions of the committee shall be final and binding upon the parties concerned. This committee shall report its decisions to the association, and their report shall be incorporated in the annual report of proceedings of the association.

RULE 31. In the revision of these rules by the association a two-thirds vote shall be necessary for adoption.

Voting powers shall be the same as prescribed in the constitution of the Master Car-Builders' Association on matters pertaining to the adoption of standards and the expenditure of money.

RULE 32. This Code of Rules shall take effect September 1, 1894, and shall be introduced for discussion and revision at one session of the Master Car-Builders' Association Convention each year.

Interchange of Traffic. Rules governing the condition of, and repairs to, passenger-cars:

1. Each railway company shall give to foreign cars, while on its line, the same care and attention that it gives its own cars, except in case of cars on which work is done under special agreement existing between the company owning the cars and the road operating the same.

2. Cars must be delivered in good running order, and returned in as good general condition as when received.

3. The receiving road is authorized to make such alterations and repairs as are necessary for the safe movement of cars over its line, and must immediately notify the delivering road of all such alterations and repairs, upon receipt of which notification the delivering road shall furnish proper authority to render bill for such alterations and repairs.

4. Authority must be furnished for the replacement of wheels and axles if in the following condition:

WHEELS.

(a) Loose wheels.

(b) Variation from gage beyond the limits as prescribed in the Rules of Interchange for freight-cars.

WHEELS, CAST-IRON.

(a) Shelled out, with treads defective on account of circular pieces shelling out, leaving round, flat spots, deepest at the edges, with raised centers, if 1 1/4 inches or more in diameter.

(b) Tread worn hollow; if tread is worn sufficiently hollow to render flange or rim liable to breakage.

(c) Worn flange; flanges having flat, vertical surfaces, extending more than 3/8 inch from tread.

(d) Flat spots; if flat spots, caused by sliding, exceed 1 1/4 inches in length.

(e) Burst; if wheels are cracked from the wheel fit outward by pressure from the axle.

(f) Flanges, rim, tread, plate or brackets, either cracked, chipped or broken in any manner.

WHEELS, STEEL-TIRED.

(a) Loose, broken or cracked hubs, plates, bolts, retaining ring or tire.

To Company, Address, For Wheels and Axles put under		WHEELS OR AXLES APPLIED.						Total Net Charge.
		Shop Marks on Wheels and Axles.	New or Second Hand.	No. on Wheel or Axle.	Date Cast.	Maker.	Material. Net Charge.	
Date and Place.		WHEELS AND AXLES REMOVED.						Received payment, \$ Date, 189
		Initial, Kind and Number of Car.	Shop Marks on Wheels and Axles.	No. on Wheel or Axle.	Date Cast.	Maker.	Cause of Removal.	

(b) Worn flange or tire; with flanges less than $\frac{1}{4}$ inch thick, or having flat, vertical surfaces extending more than $\frac{1}{4}$ inch from tread, or with tire thinner than is shown in fig. 5489.

(c) Flat spots; if flat spots, caused by sliding, exceed $\frac{1}{4}$ inches in length.

AXLES.

Axles bent or broken, or having journals cut or less than $3\frac{1}{2}$ inches in diameter.

5. Brakes must be in perfect working order (adjustment based on seventy pounds as the initial pressure), with a piston travel of not less than 5 inches, nor more than 8 inches.

6. Bills for wheels and axles shall be of the accompanying form, and must make specific mention of each wheel and axle removed or applied:

	New	Second-hand.	Scrap.
1 36-inch Cast Wheel	\$11.00	\$8.00	\$5.00
1 33-inch Cast Wheel	9.00	6.50	4.50
1 axle, 60,000 lbs.	10.00	6.00	4.00
1 axle, 40,000 lbs.	9.00	5.50	3.50

7. Bills rendered for labor and material furnished shall be in accordance with the following prices, with the proper debits and credits:

	New.	Credit for Scrap.
Journal bearings	15 cents.	9 cents.
Malleable Iron	3½ "	½ "
Bolts, Nuts, Wrought Washers and all Wrought Iron except Axles	4 "	1 "
Castings	16-10 "	5½ "
Spring Steel (not Springs)	5 "	¾ "
Lumber: Oak, Pine, Poplar, Hickory and Elm	3 "	
Labor	25c. per hour.	

All steel castings and steel wheels of the different makes to be charged at current market prices.

Removing, turning and replacing a pair of steel-tired wheels, \$7.

Removing and replacing a pair of cast-iron wheels, \$2.

Loss of service metal from steel-tired wheels as a result of slid spots or other causes, to be charged at the rate of \$2 per $\frac{1}{16}$ inch thickness of tire.

Glass, paints and other materials to be charged at current market prices.

Interior screw-tube (of student-lamp). One of a pair of tubes having a screw on them in such manner as to raise or lower the wick by revolving the burner.

Intermediate floor (passenger-cars). 28, figs. 550-560. A floor consisting of boards placed between the sills and between the *deafening-ceiling*, or under floor, and the upper or main floor. Its purpose is to exclude noise and cold. The tendency is to use no other *deadenir g* material in car-floors.

Intermediate gear (of hoisting-gear). One or more shafts carrying additional gear-wheels to give more power and slower motion when the *shifting-pinion*, which see, is shifted into the gear-wheel.

Intermediate platform timbers. Figs. 1228-29.

Intermediate-seat cross-rail. 256, fig. 5662.

Intermediate sills. 3, figs. 229-567, etc. The two main longitudinal timbers underneath the floor between the side-sills and the center-sills.

Internal cylindrical gage. A very accurately made solid steel cylinder used as a standard of measurement of cylindrical holes.

Internal screw-gage. A solid steel cylinder with a screw-thread on it, for testing the diameter of female screws.

Internal tire-flange (steel-tired wheels). Figs. 5329-5266. A flange by which the tire is bolted to the wheel-center.

Inverted arch-bar (diamond-truck side frames). 15, figs. 4576-4805. A wrought-iron or steel bar which rests on top of the journal-boxes with the *arch-bar*, which see, on top of it. Also sometimes called the *middle* or *lower arch-bar*, as in logging cars. See *Center-bearing inverted arch-bar* (for six-wheel trucks), 67, figs. 4961-6.

Inverted body-queen-post. A post in the side of a car-body which supports the *inverted body-truss rod* or *overhang truss-rod*.

Inverted body-truss-rod. A truss-rod used as a *hog-chain*, which see, to prevent the ends of a car-body from sagging. It rests on two *queen-posts* on top of the sill, and is attached to the latter at each end, bearing against an *inverted truss-rod plate*. An *overhang truss-rod*.

Inverted truss-rod plate (street-cars). 25, fig. 1843. See above.

Iron. See

<i>Carry-iron.</i>	<i>Safety-beam iron.</i>
<i>Cricket-iron.</i>	<i>Step-iron.</i>
<i>Knee-iron.</i>	<i>Truck-frame knee-iron.</i>
<i>Pull-iron or switching iron or roping staple.</i>	<i>Truss-rod iron.</i>

Iron body-bolster. Figs. 1431-57. A body-bolster, which see, of iron, usually made in the form of a truss, consisting of two flat bars, the *body-bolster top-plate* and *body-bolster bottom-plate*. *Double-iron body-bolsters*, which see, are also used.

Iron car-seat. Figs. 3954-5. See *Car-seat*.

Iron truck. A car-truck of which the *side-frames* are made wholly of iron. See *diamond truck*, which is the principal type. These are often made of iron with wooden transoms and spring-planks, although iron transoms are now used in many cases. Figs. 4576-8, 4644-8, 4753-7, are illustrations of iron freight-car trucks, and figs. 4809-12 of passenger-car trucks, the latter being rarely of iron.

Italian hemp bell-cord. See *Bell-cord*.

Jack. See *Jack-screw*, also *hydraulic-jack*, figs. 3728-52; *lamp-jack* and *lever rack-jack*; *screw-jack*, figs. 3733, 3736-9, 3743-4; *smoke-jack*, or *stove-pipe jack*; *ventilator-jack*, etc.

Jackets for Steam-heating (Safety's). Figs. 3039-42, 3043-45, 3051-55. The figures show in detail the construction of the *single jackets*, *coil jackets* and *double jackets* respectively. The inner or the *water circulation pipes* are of brass or copper, and therefore most efficient conductors of heat. Leakage of steam from steam spaces past the water pipes is prevented by packed glands shown. Coil jackets are always furnished in pairs, *right* and *left*, as shown. See *Drums*.

Jack-screw. Figs. 3733, 3736-9, and 3743-4. 1. A tool or machine for lifting or raising heavy weights. It consists of one or more screws, turned by a lever and working in a case, which rests upon the floor or ground, as shown in the figure.

Jacks take various names from their forms, sizes and shapes, and are designated as *Bell-base*, *Broad-base*, *Claw*, and *Low*, and also from the uses for which they are designed, as *Journal-box jacks*, *Traversing-jacks*, *Track-jacks*, etc. See *Hydraulic jack*.

2. (For pile-driver car.) 21, figs. 401-4. A jack-screw working on a *jack-screw pin* attached to the body, for relieving the springs of the cars from action and making the platform a rigid body. Tongs or crabs attached to the track are used to prevent the car body from rising upward when on the jack-screws. Another device for this same purpose is a *bolster jack-screw*.

Jamb (of a door). 1, fig. 1788. The *door-post* on each side of the door proper. *Ash-pit jamb*, which see, is a similar use of the term.

Janney car-coupler. Figs. 2161-82, 2252-4. A drawbar arranged to couple cars automatically, invented and patented by E. H. Janney in 1870. The outer end of the drawbar is made of a forked or U-shape, and to one arm an L-shaped *knuckle* is pivoted. When the two drawbars come together, the two knuckles engage into each other. The axis of the drawbar therefore remains always fixed, and does not move sidewise to couple as in the Miller coupler.

In the passenger coupler, when the knuckles engage, the rear point of one or both of them is thrown back, and in its rearward motion it displaces a *catch*, which

snaps back over the point of hook and secures it in place. The motion of the catch is controlled by the *catch-spring*, which slides on the *catch-spring bolt*. The draw-bar is cast hollow to contain the knuckle, catch and attached parts.

The buffers are caused to act simultaneously with the draft-gear, so that the stronger the tension on the latter the stronger the compression on the buffers, by means of the *horn* and *yoke-lever*. The buffer comes forward whichever way you move the coupler. The manner in which this is effected is highly ingenious, and is described under Janney-Buhoup platform-equipment. The *main draft-spring* acts as a buffer-spring in compression. The *centre buffer-spring* acts as a buffer-spring in either compression or draft. Whether in buffing or in draft the faces of the buffers are always kept in contact; the buffers follow the movement of the coupler forward.

To uncouple, a *platform-lever* draws a *pull-rod* which operates a *catch-lever* and unlocks the knuckle, permitting the same to swing upon the knuckle-pin. A recent improvement is the *Janney-Buhoup*, which see.

A long list of parts, as follows, are sometimes named with and sometimes without the prefix *Janney*. The following is a substantially complete list of all parts of the Janney and Janney-Miller coupler, except those entitled *combination*, etc., which see.

Auxiliary draft-spring, Barrel of Janney-Miller coupler, Brake-shaft stand, Buffer (flat face), Buffer (round face), Buffer, guide, Buffer-washer, Catch, Catch-lever, Catch-spring, Catch-spring bolt, Center buffer-spring, Center-spring washer, Chafing-plate, Combination stop-brace, Combination yoke, Coupling-pin, Coupler-pin spring, Coupler-pin washer, Draft-bolt, Draft-iron, Draft-washer, End-face plate, Equalizer, Follower, Foot-plate, Fulcrum-bolt, Fulcrum-ferrule, Half-oval washer, Head (Janney-Miller coupler), Horn, Horn-bolt, Knee-strap, Knuckle, Knuckle-pin, Lever-guard, Long T-bolt, Main draft-spring, Passenger coupler, Platform lever, Platform lever jaw, Platform lever pin, Pull-rod, Pull-rod button, Pull-rod plate, Short T-bolt, Stirrup, Tail-pin, Thimble, Tie-bolt.

Janney-Buhoup platform equipment. Figs. 2301-50. A draft-gear of the Janney type now in quite general use, and which is replacing the other types of *Janney* draft-gear. Like the Janney equipment the coupler has a direct and a reverse connection with the buffers by which they are forced out whichever way the coupler is moved.

The direct connection by which the buffers are pulled out with the couplers is made by interlocking the *back-follower plate* with a *thrust-bottom*, 150, fig. 2301, which impinged against the *buffer-stem equalizing-bar*, 134, through the top of the *Yoke-lever*, 135, and the *U-bolt*, 144. Any outward movement of the coupler is given directly (after the lost motion has been taken up) to the *buffer-stem equalizer*, 134, and through the *buffer springs* to the *buffer-stems*, 133, and *buffer-plate*, 168. The movement of the *buffer-stem equalizer* is greater than that of the coupler in consequence of the greater leverage which it has over the *bottom thrust*, as shown in fig. 2350.

The reverse connection by which the buffers are thrust out when the coupler is forced in, is effected by the *yoke lever*, 135, the lower end of which is connected to the coupler by a *yoke connecting bolt*, 143, the upper end to the *buffer-stem equalizer* by a *U-bolt*, 144, and pivoted near the middle to the draft timbers by a *fulcrum-bolt*, 12. When the coupler is forced in, the movement is carried by the *yoke-connecting rod* to the lower end of the *yoke-lever* and the *yoke-lever* reverses the motion and conveys it to the *equalizer*, 133, and by the *buffer springs* to the *buffer-stems* and *buffer-plate*. The connection between the coupler and lower end of *yoke-lever* is such that it holds only when the coupler is thrust in: the bolt being loose to outward movements of coupler, as may be seen.

Janney freight-coupler. Figs. 2161-82. One of the M. C.-B. automatic couplers, with a gravity lock.

Janney-Miller coupler. A modification of the Janney

coupler so as to enable it to be rapidly changed into an equivalent of the Miller coupler, thus enabling cars provided with it to be run in connection with either Janney or Miller draw-gear. The principal changes to effect this end were as follows:

A joint was made in the barrel of the ordinary Janney coupler to provide for the removal of the head when it was desired to change to the Miller. There was added the part called the *center buffer-yoke* in order to provide a connection between the center buffer spring and center buffer when used as a Miller coupling, the same springs being used, whether in use as a Janney or as a Miller coupler.

A spiral spring called the *side-spring*, with its bracket and clevis, was added to give the necessary side resistance to the Miller hook. The platform lever was lengthened for the purpose of conforming to the difference in heights between the Janney catch-lever and the chain by means of which the Miller hook is moved in uncoupling, the same lever serving for either draw-gear. Followers and guides were provided and placed back of the center buffer-spring to form a better base for that spring when used in connection with the Miller buffer. The Miller stop was added to the Janney platform. After a little practice the change from the Miller to the Janney gear was made in from two to five minutes.

Since the general adoption of the M. C.-B. Coupler, this coupler and buffing apparatus has been changed, whenever opportunity has been afforded, to the *Janney-Buhoup*, figs. 2301-49, the *Janney*, the *Gould*, or other platform equipments. Before many years it will doubtless be obsolete, if indeed it may not be so called now.

Jaw. *Pedestal-jaw*, figs. 5480-3.

Jaw-bit. A bar extending across the mouth of a pedestal-jaw underneath a journal-box and bolted to the horns of the pedestal.

Jaw-bolt. 85, figs. 4740-1. A bolt with a U-shaped split head, perforated to carry a pin. Used largely as a *brake-lever fulcrum* on break beams.

Jaw-spring. A *journal spring*, which see.

Jib (of a derrick or crane). 2, figs. 389-96. More properly *boom*, which see.

Johnston-coupler. Figs. 2183-90.

Joint. See *Head-joint*. *Scarf-joint*. *Three-way joint*.

Joint-bolt. Fig. 3720; fig. 559, etc. A bolt used for fastening two timbers when the end of one joins the side of another. The *lug-bolt* is another form for the same purpose.

Joint-cover. See *Window-molding joint-cover*.

Joint-strip (of Winslow roof). 1, figs. 2357 and 2361. A strip of wood with rabbeted grooves for inserting the corrugated *roof-sheets*. A *cover-strip* is a U-shaped strip of metal for uniting flat roof-sheets.

Journal (M. C. B. standard). Figs. 5133, 5138, 5149, 5419-20. The part of an axle or shaft on which the *journal-bearing* rests. A *gudgeon* is a rough form of journal, usually of wood with an iron strap around it, as for the mast of a derrick or crane. The journals of bodies of irregular shape, like cannon or leaders of pile-driver cars, are more commonly designated *trunnions*, which see. For standard minimum dimensions for various roads, see *Interchange of Traffic*.

Journal-bearing. Figs. 5394-8, 5411-18. A block of metal, usually some kind of brass or bronze, which see, in contact with a journal, on which the load rests. In car construction the term when unqualified means a car-axle journal-bearing. A standard form has been adopted by the Master Car-Builders' Association, and is shown in the engravings, but its composition is not specified. The *Hopkins* or *lead-lined* journal-bearing is one coated on the inside with a thin sheet of lead to make it self-fitting on journal. *Babbitt-metal* in some of its many forms is used for car-journal bearings occasionally, and almost universally for the bearings of machinery. In order that

the journal-bearing may be more easily removable, and to distribute the load more equally, a *journal-bearing key*, also called a *wedge*, etc., is used to hold the journal-bearing in place. The term "wedge" is in very common use, perhaps more common than the name here given. To remove the brass a *journal-box jack*, figs. 3730-1, 3743-4, 3752, is used to take the load off the bearing by inserting it under the journal-box, when the wedge or key can be readily removed, and afterwards the bearing itself. See *Stop journal-bearing* and *stop-key journal-bearing*.

Journal-bearing and wedge-gage. Figs. 5556-71. In 1894 a Recommended Practice was adopted for gages for journal-bearings and wedges, to insure their proper interchangeability and freedom from binding when in place. The set comprises:

- Two bearing and wedge cross-section gages.
 - " " " " longitudinal-section gages.
 - " " flanged side-lug gages.
 - " " bore-gages.
 - One " thickness-gage, common to both sizes.
- See figures.

Journal-bearing key or wedge. M. C. B. standard, figs. 5389-5418. See above.

Journal-bearing stop-key. 27, figs. 5133, and figs. 5135-7. M. C. B. Figs. 5389-5418. A journal-bearing key with a projection to which a *stop-plate* is attached to restrain lateral play, so that a collar on the axle may be dispensed with.

Journal-box. Figs. 4970-3, 5133-66, 5377-87, etc. A cast-iron box or case which incloses the *journal* of a car-axle, the *journal-bearing* and *key*, and which holds the *packing* for lubricating the journal. Also called an *axle-box*, *car-box*, *grease-box*, *housing-box*, *oil-box*, and *pedestal-box*. English, usually *axle-box*.

The weight of the *Master Car-Builders' Standard journal-box* is 74 lbs. All car journal-boxes are *outside-bearing*. In certain larry or push-cars, and also in locomotive trucks, *inside-bearing journal-boxes* are used. To dispense with the need of a collar on the axle, various devices, like the Raoul journal-box, figs. 5165-6, as well as stop-key and stop-journal bearings, 5133-48, have been introduced, and they are in increasing favor.

Journal-box and details. (M. C. B. standards.) 5377-88. 1. Journals, 3 $\frac{1}{2}$ by 7 inches. The journal-box and details as shown were adopted as standards of the association, by letter ballot, in 1893, and revised in 1894.

The revision made in 1894 consisted in correcting the drawing at the top of the journal-box, and in leaving off the lugs at sides of arch bars. Also in changing the wedge and bearing so as to make the latter flat on top instead of curved, as theretofore, and in curving the top of the wedge, as in figs. 5389-5401, thus making this construction similar in general arrangement to the standard forms for the 4 $\frac{1}{2}$ by 8 inch journal box. Figs. 5406-18.

The figs. 5377-82 shows the standard journal-box of 1893 with the arch-bar lugs, and bearing curved instead of the *wedge*.

The width of the box over all where the lid fits should be 7 $\frac{1}{2}$ inches, in accordance with ballot of 1891, instead of 7 inches as shown, so as to take the same lid, figs. 5402-5, that the journal-box for the 4 $\frac{1}{2}$ x 8 in journal takes.

2. For journals, 4 $\frac{1}{2}$ by 8 inches, 5383-8. The journal-box and details as shown were adopted as standards of the association, by letter ballot, in 1893.

Journal-boxes. M. C. B. journal-boxes, figs. 5377-87; *Pullman*, figs. 4970-3; *Bissell*, figs. 5133-7; *C. B. & Q.*, figs. 5138-45; *Adams*, figs. 5146-51; *Schoen solid pressed steel*, figs. 5161-4; *Raoul*, figs. 5165-6.

Journal-box cover, or lid. Figs. 5167-75. M. C. B. Figs. 5402-5. A door or lid covering an aperture on the outside of a journal-box, by means of which oil and packing are supplied and journal-bearings are inserted or re-

moved. Such covers are made of cast-iron, malleable-iron, pressed-steel, and sometimes of wood. They are usually closed by a spring, as in figs. 5402-5, 5152-3, 5167-75, which see, and sometimes not, as in the *Hewitt lid*, figs. 5170-1.

Journal-box cover-bolt. A bolt used to fasten covers which have no hinge to the box. Two of these are usually employed to each cover. A *gasket* of canvas, rubber or leather is used to make a tight joint. Journal-box covers are, however, now almost invariably held on by hinges and springs or some arrangement of lugs or grooved joints.

Journal-box cover gasket. Nearly obsolete. See above.

Journal-box cover hinge-pin. Fig. 5405.

Journal-box cover spring. 1. Figs. 5383, 5167-9, 5172-5. A flat spring to hold the lid in place. Various journal-box lids are in use, as the *Hewitt*, which see, which dispense with a spring.

2. (For Fletcher journal-box lid, which see.) Figs. 5152-3. A spiral spring slipping over a sleeve which slips over the bolts. The drawing is not quite correct, as it does not show this sleeve and does show a pin not used. The spring is frequently made a part of the cover, as in figs. 5167-9.

Journal-box guides. Figs. 4753-6. Iron bars or blocks placed one on each side of the journal-boxes of some iron frame trucks in which *journal-springs* are used. These irons, while holding the box in place longitudinally and transversely, allow it to have a vertical motion between them. When a pair of these guides is cast in one piece it is called a *pedestal*, which see.

Journal-box jacks. Figs. 3731, 3743-4, 3752. A low jack specially designed to set under journal-boxes, take the weight off the journal, so that brasses can be removed as from a hot box.

Journal-box lid. Figs. 5167-75, 5152-3; M. C. B., figs. 5402-5. See also *Journal-box cover*.

Journal brass. A *journal-bearing*, which see.

Journal-packing. Waste, wool, or other fibrous material saturated with oil or grease, with which a journal-box is filled to lubricate the journal. Various forms of patent packing have also been introduced.

Journal-spring. Figs. 4766-7 and shown in 4578, 4753, etc. A spring supporting part of the weight of a car which is placed directly over the journal, and which usually rests on the journal-box under the truck-frame. Such springs are sometimes placed above the truck-frame and supported by straps, and the weight of the car is transmitted to the journal-box by a vertical pin or stirrup. *Equalizer-springs*, which see, accomplish the same end in six-wheel trucks as journal-springs, and more effectually.

Juergens spiral-elliptic seat-springs. Figs. 4001-2.

Jull centrifugal snow-excavator. Figs. 226-7. See *Snow-plow*.

Jute. A coarse fibre raised in India for making gunny-bags, matting, ropes, etc. It has been recently used for making journal-packing by a patented process.

K

"Kalamazoo" all-steel hand-car wheel. Figs. 5632-4. A double-plate wheel, the two concaved steel discs forming a substantial bracing for the outer and inner side of tire. The tire is pressed out of wrought steel, and is curved over on the inner edge so as to make the rail flange. The outer edge of tire is turned down to form a point of attaching the separated discs to the tire. The edges of the discs are separated by a felloe and the center by a cup-shaped casting. The hub is a malleable cast shell with a cup or flange on one end, and in connection therewith is another malleable iron flange which is pressed over the opposite end of the hub. Between these two flanges or caps and the cup-shaped casting the steel discs are placed, and securely riveted. A

malleable ring fits against the outer edge of the inner disc, and steel bolts secure this ring, the two discs and felloe between the discs, to the turned down edge of the tire.

"Kalamazoo" hand-car. Figs. 5581-2. A lever hand-car whose special features are the steel-wheels, roller-bearings, and framing details.

"Kalamazoo" inspection velocipede-cars. Figs. 5614-16.

"Kalamazoo" three-wheeled hand-car. Figs. 5609-11. A very light and easy-running inspection hand-car for the use of one or two men only.

Kalamined iron. Sheet-iron, coated with an alloy of zinc, lead, tin and nickel in the proportion of 29 lbs. of tin, 50 to 75 lbs. of zinc, 100 lbs. of lead, and three to six ounces of nickel. The alloy melts at a lower temperature than common zinc, and is claimed to give a more durable compound as well as a thinner and more adhesive coating. *Galvanized iron* is sheet-iron coated in the same way with pure zinc.

Keeper. "A ring, strap, pocket, or the like device for detaining an object; as

1. "A jamb nut.

2. "The box on a door-jamb into which the bolt of a lock protrudes when shot, as figs. 2541-2, 2645-2735. When the keeper is for a beveled *latch* bolt, which is moved by contact with it, it is more commonly called a *strike-plate*, as figs. 2638. They are also further designated by the name of the lock or latch which they accompany.

3. "The latch of a hook, which prevents its accidental disengagement."—*Knight*.

Keeper. 112, fig. 2161. (4), (Janney-freight coupler).

A bracket for the uncoupling rod; the one directly over the coupler.

Keg-shaped spiral-spring. Fig. 5242. A spiral-spring, the form of which resembles a keg or cask, patented by W. P. Hansell in 1876. Its object is to obtain a *graduated* spring, which see.

Keewanee break-beam. Figs. 1581-6. A steel break-beam of rectangular cross-section, and a bar for truss-rod, which is bent around the ends of the beam proper.

Key. 1. "In a *general sense*, a fastener; that which fastens; as a piece of wood in a frame of a building."—*Webster*. Hence a pin inserted in a hole in a bolt, and used to secure the bolt or its nut. A *split-key*, which see, is a special form.

2. Figs. 2716, 2720. "An instrument for opening or shutting a lock by pushing the bolt one way or the other."—*Webster*. See *Lock*. See *Bit*.

3. A block over the top of a journal-bearing, called in full *journal-bearing key*. Figs. 5389-93, etc., which see. This part is also very commonly called a "wedge."

4. A beveled bar used with a *gib* to form a *gib and key*, which see. See also *King-bolt key*.

5. (For coupling-valve of Westinghouse brake.) A kind of wrench having pins fitted into corresponding cavities.

6. (For lamps and valves of Pintsch gas apparatus.) Figs. 3214-15. A substitute for the ordinary cocks of gas fixtures to prevent unauthorized tampering.

Key-block. 186, figs. 229-66. See *packing-blocks*.

Key-bolt. Fig. 3714. A bolt slotted near the end to receive a key, which takes the place of a nut.

Key-hole escutcheons. See *Escutcheons*.

Key-hole plate. An *escutcheon* or *escutcheon-plate*, which see.

Key-pin (of a lock). The pivot on which the key turns when inserted in the lock.

Key-ring tire fastening Fig. 5342. A mode of securing the tire to the wheel, composed of two rings, one of U-section, and the other nearly rectangular. The former *ring* holds tire and wheel together, and the latter ring holds the former in place, filling up the groove in the

tire. When both rings are in place the outer tip of the groove in the tire is slightly hammered over, thus gripping the second or key-ring, and retaining it in place. See also *Tire fastening*.

Keystone car-seal. Figs. 3892-a.

Keystone palace horse-car. Figs. 43-4. See *Stock-car*.

Kimball's Turnbuckle. See *Turnbuckle*.

King-bolt, or center-pin. 18, figs. 229-66. 16, figs. 435-73. A large bolt which passes through the truck and body-bolsters and center-plates of a car-body and the center of a truck. It is accessible from the floor of the car by removing the *king-bolt plate*. The truck is supposed to swivel on the king-bolt, but in reality the two center-plates normally carry all the strain. In some wrecking-cars, fig. 392, the king-bolt is provided with *keys* to bind the truck to the car so that they cannot be separated from each other.

King-bolt key (wrecking cars). Fig. 392. See above. They are distinguished as the *upper* and *lower* key.

King-bolt plate. See above.

King-post (of a truss) A single post or distance-piece between a *truss-rod* and the *chord* of a truss or beam. If two such posts are used they are called *queen-posts*. In car construction king-posts are made in two ways; one adjustable, so that they may be lengthened or shortened, and the other without adjustment. Also see *Brake-beam king-post*. *Cross-frame king-post*. *Truck-bolster king-post*. *Truck-frame king-post*.

King's doors (Hopper-bottom coal-cars). Figs. 324a. A pair of doors which are inclined slightly from a vertical hinged at the top, and hung from two cross-tie-timber near the middle of the car and which are opened and closed by a toggle joint, moved by a lever in connection with a bell-crank. In order to raise the toggle joint high up the lever arm works upon the arc of a circle shown.

Kirby's car-door lock. Figs. 2628-9. A device to give a lock extra strength and durability and to dispense with the use of screws for fastening on the door-knobs.

Kirby's seat-lock. Fig. 4022.

Kirtley double-spoke wheel. A car wheel, the hub (boss), spokes and rim of which are composed wholly of wrought iron welded together, the tire being shrunk on and secured by *Mansell retaining-rings* or other devices.

Kitchen (dining car). Figs. 474-5. A large compartment at one end of the car provided with all the facilities of a well-organized kitchen. Officers' and other private cars are commonly provided with a kitchen smaller than in dining cars and usually at the extreme end.

Knee-timber (Janney platform). Fig. 2301. A deep *platform-sill*, cut away to embrace the end-sill.

Knee. 1. See *Platform-hood knee*.

2. (Snow-plow framing.) 23, figs. 410-3.

Knee-iron. An L-shaped or angle-iron casting or forging which is fastened to the corner where two timbers are joined to strengthen the joint. See *Sill knee-iron*. *Truck knee-iron*.

Knee-strap (Janney coupler). Fig. 2301. A wrought-iron facing to the knee-timbers, connecting the end-sill and the stirrup or drawbar carry-iron.

Knob. See *Berth safety-rope knob*. *Door-knob*. *Window-curtain knob*.

Knob-escutcheon. Figs. 2634-43. A *Door-latch rose*, which see.

Knob sash-lift. See *Sash-lift*

Knob-shank. Fig. 2632. A *doorlock spindle*, which see.

Knotted spiral seat-spring. Fig. 4010. One with the loose ends of the wire tied. See *Seat-spring*.

Knuckle. 1. (M. C.-B. couplers.) 2, figs. 2088-2144. The rotating coupling-hook by means of which coupling is effected when the knuckle is locked by the *catch* or *lock*. It must conform to certain contour lines adopted by the M. C.-B. Association in 1888 and shown in figs. 5499-5501.

2. (Of a hinge.) Figs. 2586-2600. The central tubular projections which carry the hinge-pin. The term is of wide and general application in mechanics to many similar parts.

Knuckle, automatic coupler, contour line and limit gages. Figs. 5499-5501. Standard contour line was announced by Executive Committee under instructions from the Master Car-Builders' Association April 8, 1888. Limit gages for preserving standard contour line were adopted in 1891.

These gages, properly proven by master gages, may be procured from Pratt & Whitney Company, of Hartford, Conn. A duplicate set of master gages is held in the office of the Secretary for reference when desired.

Knuckle-joint. "A joint in which a projection on each leg or leaf of a device is inserted between corresponding recesses in the other, the two being connected by a pin or pivot on which they mutually turn. The legs of dividers and the leaves of door-hinges are examples of true knuckle-joints. The term, however, has been somewhat commonly restricted to *compound* or *universal* joints designed to act in any direction."—*Knight*. Among the applications of this joint which have been made in car building are gas-pipe knuckle-jointed tubes to be used instead of rubber for brake-hose. They are not yet in general use.

Knuckle-pin (M. C. B. coupler). 3, figs. 2088-2144. The steel pin connecting the knuckle to the jaws of the coupler.

Krupp safety-lock (for steel-tired wheels). Figs. 3938.

Krupp steel-tired car-wheels. Figs. 5298-5305.

L

Label-holder (postal-car). Figs. 3828-31, 3837. Made both *single* and *double*. Sometimes combined with a drawer-pull.

Lace (English). See *Broad lace*. *Pasting lace*. *Scaming lace*.

Ladder. 1. 59, figs. 229-66. Bars of wood or iron attached to the side or end of a box-car so as to form steps by which persons may climb to and from the top of the car.

The individual bars, whether of wood or iron and whether round or square, are termed *ladder-rounds*. They are sometimes made with *ladder side-rails*, which see. The handles alongside of the ladder are termed *grab-irons*, or *hand holds*, or sometimes *corner-handles*; that placed on the roof near the ladder, the *roof grab-iron* or *ladder hand-hold*.

The M. C.-B. Association has recommended that "each box and stock-car should have two iron or wooden ladders not less than five steps to each ladder; the steps to be not less than 2½ inches from side or end of car; each ladder to have a handhold on the roof directly over top of ladder. When iron ladders are used and placed on ends of car, the bottom step to have a guard or projection to prevent men from slipping when swinging around the end of car to get on the step."

"When the ladder is placed on the ends of car, a handhold should be placed on opposite side of the end of car from the ladder, and when ladder is on sides of car, two such handles should be placed on each end of car about 24 inches above the bottom of the sill." See M. C.-B. Association Proceedings, 1879, 1893, and 1894.

2. (For pile-driver car.) 32 and 33, figs. 402. A means of approach to the upper end of the leaders. They usually swing on *ladder-trunnions* so as to be dropped on the roof of the cabin when the car is not in use. There is usually also a *cabin-ladder*, 8, against the side of the cabin or engine-house.

Ladder-handle. 60, figs. 229-66. A *roof grab-iron* or *hand-hold*, which see.

Ladder-rod. An iron *ladder-round*.

Ladder-round. 59, figs. 229-66, etc. See *Ladder*. The lower round of the ladder by recommendation of the

Master Car-Builders' Association should be a *bent ladder-round*, as figs. 246, 256, as a safeguard against the slipping of the foot in swinging around the corner of a car.

Ladder side-rails. The wooden vertical side pieces to which wooden or iron ladder-rounds are attached. This form of constructing the ladder is more common than ladder-rounds directly secured to the end of the car.

Lag-post. Figs. 1192-5, etc.

Lag-screw (English, coach-screw). Fig. 3711. An iron bolt with a square or hexagonal head and with a wood screw-thread cut on it, intended to screw into wood. Lag-screws are round under the head, so that they can be turned after they enter the wood.

Lambrequin (lam'-bré-kán). 28, fig. 4551. A cloth or drapery fastened over the upper part of a window. It covers the rod and rings or roller of the window curtains. The *lambrequin* has been replaced by *Valances*, which see. B, fig. 2452.

Laminated buffing-spring (English). A half-elliptic spring. See *Plate buffing and draft-spring*.

Lamp. Figs. 3133-40, 3235-3317. "A vessel for the combustion of fluid inflammable bodies for the purpose of producing light."—*Webster*. The chief forms of lamps now used are for burning gas and mineral oil or petroleum, though *candle lamps* are used in cases of emergency, as also *oil lamps* for lard oil, for panel lights, lanterns, etc. Car lamps are distinguished as *side-lamps* and *centre-lamps*, the latter now usually consisting of two or more distinct lamps, forming a *chandelier*. In England *roof-lamps*, inserted from the roof of the car, are exclusively used. Lamps are also distinguished as *adjustable globe*, *loose globe* and *plastered or fixed globe*, which see, the latter being a form in which the lamp is removed from below and the globe cannot be taken off. Many modern lamps are constructed upon the *tornado* or *hurricane* principle, which see, to avoid the effects of draft. *Postal-car lamps* or *chandeliers* are a special class, in which every means possible is used to obtain a powerful light. See also *acme-lamp*, *alcove-lamp*, *gas-lamps*, *signal-lamp*, *tail-lamp*, etc.

Lamp-alcove. A metal casing or lining for a recess in the side of a car to contain an *alcove-lamp*, which see.

Lamp-arms. 4, figs. 3261-2, 3310-17. Rods by which a lamp is attached to the ceiling of a car. Some lamp-arms have bracket-angles to support the shade and are then called *bracket-arms*.

Lamp bottom. 20, figs. 3261-3317. The lower portion of a lamp which is removable. Contains the wick, burner and oil. See *Candle-bottom*.

Lamp-bracket. See *Side-lamp bracket*.

Lamp-burner. Figs. 3363-99; 8, figs. 3261-3317. That portion of a lamp by which the opening on the top of the reservoir is closed, which holds the wick, and by which the latter is adjusted. A great variety of styles exist and are shown. See engravings. The *acme* and *dual burners*, which see, are favorites for car service where a brilliant light is wanted, but many forms are used. The name *burner* is also applied to the tips of a gas-light in the *Pintsch gas* system. See fig. 3211.

Lamp-burner (English). 165, fig. 501. The wick-holder in the *roof-lamp*, which see.

Lamp-canopy. Figs. 3438-53. A large and elaborate *smoke-bell*, which see.

Lamp-case (street-cars). 1. A box over the end windows in which a lamp is placed. It has a glazed door on the inside and usually colored glass on the outside as a signal to designate the line to which the car belongs. It is fastened by a *lamp-case hook* and *eye*.

2. (English.) 160, fig. 501. A cylindrical sheet of iron for the protection of the *roof-lamp*, which see.

Lamp-case base or packing (English). 167, fig. 501. A wooden packing-piece secured to the roof-boards, and presenting a level face for the *lamp-case*. See also *Roof-lamp*.

- Lamp-case chimney** (street-cars). A metal pipe through which the smoke and gases escape from a lamp-case, very similar to a *lamp-jack*, which see.
- Lamp-case door** (street-cars). See *Lamp-case*.
- Lamp-case door-holder**. A kind of hook attached to the roof.
- Lamp-case eye**. See *Lamp-case*.
- Lamp-case hook**. See *Lamp-case*.
- Lamp-chimney**. A glass tube which incloses the flame of a lamp, conducts away the smoke and gases and produces the necessary draft.
Figs. 3512-22 give what are known as the standard types, For the names of which see engravings.
- Lamp-chimney bracket**. A projecting metal arm attached to the side of a car and carrying a *chimney-holder* by which a lamp-chimney is held in place.
- Lamp-chimney holder**. Fig. 3436. See above.
- Lamp-chimney reflector**. Fig. 3290. Usually it has a hole in the center in which the chimney is inserted.
- Lamp-cover, or lamp-protector** (English). 161, fig. 501. American equivalent, *lamp-jack*. A sheet-iron cover hinged to the lamp-case and secured by a *spring-catch* to protect the lamp from rain, while it allows the smoke to escape. See also *Roof-lamp*.
- Lamp-cover spring-catch** (English). 164, figs. 501-3. See above.
- Lamp-fount**. 6, fig. 3261-3317. The receptacle for the oil burned in a lamp. Also called *lamp-reservoir*.
- Lamp-glass** (English). 166, fig. 501. In a carriage, a hemispherical glass globe of unusual thickness, which surrounds the burner of a *roof-lamp*, which see.
- Lamp-globe**. Figs. 3430-4, etc. A glass or porcelain case or vessel inclosing or surrounding the flame of a lamp or candle, and intended to protect the latter from wind. Lamp globes are approximately globular in form, in distinction from a *lamp-shade*, which flares at the bottom, but are often made of different shapes, as *round*, *pear-shaped*, *egg-shaped*, *melon-shaped*, *double-cone-shaped*, etc.
- Lamp-globe chimney**. Figs. 3259, 3308. A metal tube attached to the top of a lamp-globe for conducting away the smoke. A *shade-cup* is an equivalent device for a lamp-shade.
- Lamp-holder**. See *Side-lamp holder*.
- Lamp-hoop**. Figs. 3393. A ring with an interior screw-thread for attaching to cheap oil lamps to receive the burner.
- Lamp-iron** (English). American equivalent, *tail-light holder*, or signal-light holder. See *End lamp-iron* and *side lamp-iron*.
- Lamp-jack**. V, figs. 539-41. A cap or covering over a *lamp-vent* on the outside of a car to exclude rain and prevent downward currents of air. Also see *Lamp-case chimney*.
- Lamp-key** (Pintsch gas). Figs. 3214-15. A substitute for the ordinary cock of gas fixtures used to prevent unauthorized tampering with the burners.
- Lamp-plug** (English). 162, fig. 501. A cylindrical piece of wood secured to the lamp-case by a chain, and used to block up the lamp aperture in the roof when the lamp is not in its place. See *Roof-lamp*.
- Lamp-plug stand** (English). 163, fig. 501. A cast-iron stand on which the *lamp-plug* rests when the *roof-lamp* (which see) is in use. Its object is to prevent the lamp-plug bumping on the roof of the carriage when the train is moving.
- Lamp-reflector**. 14, figs. 3261-3317. See also *Alcove-lamp reflector*.
- Lamp-reservoir**. 6, figs. 3261-3317. The portion of a lamp which holds the oil. Also called *lamp-fount*.
- Lamp-ring**. 5, figs. 3261-3317. A metal ring at the base of a lamp, to which the lamp-bottom or reservoir and lamp-globe are attached. In center-lamps the ring is supported by the lamp-arms.
- Lamp-screw**. Figs. 3385-95. A more elaborate *lamp-hoop*, which see, with a flange.
- Lamp-shade**. 2, figs. 3261-3317. A conical shaped reflector placed over a lamp to reflect the light downward.
Figs. 3423-29 give what are known as standard forms, the dimensions of which in inches are as shown in the figures.
- Lamp-socket**. Figs. 3335, etc. A socket or dove-tail joint to which a lamp or flag is attached at the corner of a car. They are flat, inclined, angular or projecting, as may be desired.
- Lamp-stay**. 1, figs. 3261-3317. A horizontal bar, usually reaching from side to side of the clear-story, by which a car-lamp is steadied and also made more ornamental.
- Lamp-vent**. An opening in the roof through which the gases from a lamp escape.
- Lantern**. Figs. 3352-62. A portable lamp, the flame in which is protected from wind and rain by glass, usually in the form of a globe surrounded by wires called *guards*. According to the number of these wires the lantern is called *single*, *double* or *triple-guard*. The *conductor's lantern* is one with a large bail, so as to be carried on the arm, leaving both hands free. It is usually provided with a *reflector* above. *Inspector's lanterns* are generally arranged to give blue light. See *Lens*. *Signal-light*.
- Lantern and flag-holder**. A device for displaying signals on rear of trains. See *Flag-holder*. The novelty is the convenience of attachment for either a lamp or flag.
- Lappin brake-shoes**. Figs. 1633-9. A brake-shoe cast from a mixture of metals, which is a solid casting with alternate sections of hard-chilled and soft parts. The chilling of the harder sections is done in the usual manner by chilling blocks brought into contact with the molten metal. The process gives no sharply defined lines between the hard and soft sections, to make a cutting edge, as the chilled parts radiate into and mingle with the soft metal and thus disappear. The number and area of the soft sections can be increased or diminished by changing the number and size of the chilling-blocks in the mold, and the holding power of the shoe thus varied to suit the conditions of service.
- Lard-lamp screw**. Fig. 3387.
- Lard-oil ratchet-burner**. Fig. 3396.
- Large equalizing-guide** (Janney-Miller coupler). See *Equalizing-guide*. *Small equalizing-guide*.
- Large main-valve piston-head** (air-pump). 77, figs. 1691-2.
- Larry**. Figs. 5603-4. See *Lorry*.
- Latch**. Figs. 2548-78; 2637, 2644-2733. The primary sense of this word is—to catch, to close, stop, or make fast; hence, an attachment to a door, window, etc., to hold it open or shut, is called a latch. The ordinary distinction between a latch and a lock is that a lock is closed and opened with a separate key and usually has a square bolt, whereas a latch has no separate key and usually has a beveled bolt which snaps shut automatically by contact with the *keeper* or *strike-plate*. The most exact distinction between a latch and lock seems to be the form of the bolt and not the use or disuse of a key. See *Sash-lock*. Latches named from the use which they subserve are the following, which see:
- | | |
|----------------------------|---|
| <i>Berth-latch.</i> | <i>Saloon-latch.</i> |
| <i>Deck-sash latch.</i> | <i>Sliding door-latch</i> or <i>lift-latch.</i> |
| <i>Safety berth-latch.</i> | <i>latch.</i> |
| <i>Safety strap-latch.</i> | <i>Spring door-latch.</i> |
- A *sliding door-latch* or *lift-latch*, figs. 2558-78, has a beveled hook instead of a beveled bolt, but operates upon substantially the same principle. Nearly all forms of latches are *spring latches*. A *night-latch* is a large and carefully made form of an ordinary latch, which can be opened from the outside by a key. A *cupboard latch* is any form of small latch. A *rim-latch*, like a *rim-lock*,

- is one attached simply to the outside of the door in distinction from a *mortise* or *rubbed* latch (both rarely used), which is boxed into the door.
- Lateral motion.** A movement sidewise, more particularly meaning, as generally used, a side or *swing motion* of the bolster of a swing-motion truck, in distinction from the *end-play* of an axle under the journal. A *lateral-motion spring*, which is slipped over a *lateral-motion spring-pin*, is sometimes used to check the lateral movement of such spring bolsters, but this end is more commonly accomplished by splaying the swing-hangers outward.
- Lateral-motion spring.** 40, figs. 4806-4966. See above.
- Lateral-motion spring-pin.** 41, figs. 4806-4966. See above.
- Lateral-play.** Side motion of any part of a car or machinery; the space left to permit of such side-motion. See *Lateral-motion* (of a truck-bolster). *End-play* (of an axle).
- Lauder-monitor deck-sash opener.** Fig. 4335. See *Deck-sash opener*.
- Lavatory.** Figs. 3468-3572. A room provided with wash-bowl, towels, combs, brushes, etc., in which passengers may make their toilet. Parlor and sleeping-cars are provided with separate lavatories for men and women, which are separated from the *saloons*. The best and most modern coaches have a lavatory. See *Wash-room*. A *saloon* is sometimes termed a lavatory.
- Lavatory carriage** (English). A passenger vehicle in which two or more compartments have access to a small lavatory, urinal, etc. See also *Carriage*.
- Lead car-seal.** Figs. 3877-92a. Lead seals are either in the form of rivets or buttons. Both are in common use. See *Car-seal*.
- Leaders** (of pile-driver car, which see). 3, figs. 401-4. The long vertical timbers serving to guide the *hammer* (which see) in its fall. The leaders swing upon *leader trunnions* carried on the *leader-trunnion pedestal*. They are stiffened at some point midway of their length by *top-stringers* 6, *leader-braces* 7, and commonly by *pilasters* 5, at the outside, which latter serve to support the top-stringers. They are connected at the top by a *leader-cap* and at the bottom by a *leader cross-piece*, the latter attached at the side in such a manner as not to interfere with the fall of the hammer.
- Leader-brace** (pile-driver car). 7, fig. 403. See above.
- Leader-brace pocket** (pile-driver car). 17, figs. 1821-4. See above.
- Leader-cap** (pile-driver car). 9, fig. 403. A cross-piece connecting the two leaders at the top and carrying the *main-sheave* and *pile-hoisting sheave* of the hoisting-gear.
- Leader cross-piece.** 23, fig. 403. See *Leader*.
- Leader-stay.** 25, fig. 403. An oblique diagonal brace attached at the upper end to the *top-stringers* serving to stiffen the leaders.
- Leader-trunnion.** 15 and 51, figs. 401-4. See *Leader* and *trunnion*.
- Lead-lined journal-bearing.** A journal-bearing which has its inner surface covered with a *thin* layer of lead, so that it may fit itself to the journal as soon as subjected to wear. Such bearings were patented by Mr. D. A. Hopkins, and are often called *Hopkins journal-bearings*. A variety of other bearings are more or less similar, but a greater quantity of lead, or *babbitt-metal* is frequently used.
- Lead-rivet car-seal.** Figs. 3879-85, etc. See *Car-seal*.
- Lead seal.** Figs. 3877-92a. See *Car-seal*. *Lead car-seal*.
- Leaf spring** (for Miller coupling). 49, figs. 2290-92. Also called *coupling-spring*. The long spring pressing the *drawbar coupling-hooks* together in the act of coupling.
- Leakage-groove** (of Westinghouse brake-cylinder). A small passage past the brake-piston to prevent application of the brakes by trifling leakages of air.
- Leather.** See *Piston-packing leather*. *Packing-leather*. *Window-shade leather*. *Solid leather nails*.
- Leather bell-cord.** See *Bell-cord*.
- Leatheroid.** A substance somewhat resembling leather, and somewhat similar to *vulcanized fiber*, which see, in its general character and appearance. It is made by treating paper with sulphate of zinc.
- Leather-seat.** A *dust-guard bearing*, which see.
- Left-hand brace-pocket.** See *Pocket*. 40, fig. 356. If the brace were on the other side of the post and inclined the opposite way, the pocket would be right-hand.
- Left-hand seat.** A car-seat with a stationary back in such a position that the seat-end is on the left side of a person sitting on the seat.
- Left main-valve cylinder-head.** (Air-pump.) 85, figs. 1691-2.
- Left main-valve head-gasket.** (Air-pump.) 108, figs. 1691-2.
- Leg.** See *Seat-leg*.
- Leg-iron** (English). 173, figs. 501-4. See *Step-iron*.
- Leg-rest.** (Reclining seats.) 30, figs. 3924-5, 3974-5, 3996-9. A bracketted and adjustable shelf, which may be used on a chair or car-seat to support the limbs when the seat or chair is in a reclining position. It is adjusted by a *Leg-rest ratchet and leg-rest pivot-casting*, as in figs. 3924-5, or by a *Leg-rest slide*, fitting in a *Leg-rest socket-casting*, as in figs. 3974-5.
- Length** (of elliptic springs). The distance from center to center of *scrolls* when the spring is unloaded.
- Lens.** Figs. 3440-3. An optical instrument for conveying rays of light upon a fixed path or fixed point. Lenses for lanterns consist of three types, *Bull's eye*, a double-convex or plano-convex lens; *semaphore* (a mere modification of the Fresnel), figs. 3442-3, and the *Fresnel* proper, figs. 3440-1, the latter rarely used.
- Leonard hydrostatic-buffer.** Figs. 2351-4. See *Hydrostatic-buffer*.
- Letter-board** (passenger-car exteriors). 91, figs. 435-73, 539-69. A horizontal board under the cornice, extending the whole length, on which the name of the company to which the car belongs is usually painted. The letter-board occupies the *frieze* of the car, and is often so called.
- Letter-box plate.** See below.
- Letter-case label-holders.** Figs. 3815, 3836.
- Letter-drop** (postal-cars). Figs. 3820-2. A plate with a spring flap for receiving letters for the post. A *letter-box lid*.
- Lettering** (of freight-cars.) Figs. 5543-5. In 1893 the M. C. B. Association adopted a Recommended Practice for Marking Fast Freight Line-cars, as shown in figs. 5543-5. It was resolved:
- "1st. The half of side of car on which the doors do not slide to show the name of the 'Fast-freight line' spelled out in full and the car number in the Fast-freight line series immediately below it. In the same panel and within 2 ft. of the sill shall appear, in letters not over 4 in. high, the name of the railroad company owning or contributing the car, and between the same and the sill shall appear the light weight of the car, with such other information as it is found advisable to give in connection with same.
- "2d. Side doors to bear the initials of the road to which the car belongs, or the name of the line on which the car is used, together with the number of the car.
- "3d. The ends to show the initials of the 'Fast-freight line' with the car number in the fast-freight line series and the light weight just below them; no other marks will appear on ends of car.
- "4th. The half of sides of cars on which the doors do slide to be reserved for advertising symbols or trade-marks where used. The use of profuse lettering in this panel is to be discouraged, however, and it is recommended that only the simplest trade-marks or advertis-

ing signs should be used ; the capacity of the car to appear near the sill in this same panel."

Lever. "In mechanics, a bar of metal, wood, or other substance, turning on a support called a fulcrum."—*Webster.*

- | | |
|--------------------------------|---|
| See <i>Brake-lever.</i> | <i>Hand-car lever, or propelling-lever.</i> |
| <i>Brake equalizing-lever.</i> | <i>Live lever.</i> |
| <i>Center brake-lever,</i> | <i>Platform-lever.</i> |
| <i>Compression-lever.</i> | <i>Release-lever.</i> |
| <i>Cylinder-lever.</i> | <i>Roof-lever.</i> |
| <i>Dead-lever.</i> | <i>Thumb-lever.</i> |
| <i>Door-shaft lever.</i> | <i>Tripping-lever.</i> |
| <i>Eccentric-lever.</i> | <i>Uncoupling-lever.</i> |
| <i>Floating-lever.</i> | |

Lever-and-rack jack. Figs. 3740-1. See *Barrett's jack.*

Lever-bracket (air-brake). 4, fig. 1697.

Lever-faucet. Figs. 3489-90. A self-closing faucet shut by a spring and opened by the movement of a handle or lever. Also called *telegraph faucet.* They are called *vertical* or *horizontal* according to the direction of the pipe or opening into which they are fastened.

Lever-frame (hand-car). 17, 18, figs. 5592-0, 5590. A wooden frame shaped somewhat like a letter A, on top of a hand-car, which supports the lever-shaft and lever.

Lever-frame cap (hand-car). 18, figs. 5592-0. A short horizontal piece of timber to which the lever journal-bearings are fastened.

Lever-frame post (hand-car). 17, figs. 5592-00. See also *Lever-post.*

Lever-frame tie-rod (hand-car). 25, figs. 5592-00. A vertical rod by which the *lever frame-cap* is bolted to the floor-frame.

Lever-guard. A guide on the platform-rail for the platform uncoupling lever.

Lever-guide. See above and *Brake-lever guide.*

Lever hand-car. Figs. 5581-5600. The common style of hand-car, which see, worked by levers connected to cranks. These levers are usually placed horizontally, but sometimes they are vertical, as in figs. 5583-4. *Double-lever* hand-cars, to avoid danger of trouble with the dead center, have been in use. See *Hand-cars.*

Lever-handle (hand-car). 20, figs. 5592-00.

Lever-jaw (Janney platform). The cast-iron jaws upon which the *platform uncoupling-lever* has its fulcrum.

Lever-jaw pin (Janney-Miller coupler). A pin for the *lever-jaw.* See above.

Lever-shaft (hand-car). 21, figs. 5592-00. A short iron shaft to which the *propelling levers* are attached.

Lever-shaft bearings (hand-car). 22, figs. 5592-00.

Lid. See *Journal-box cover, Journal box-lid, Saloon seat-lid.*

Lift. A finger-hold attached to windows and window-blinds to take hold of in raising or lowering them. See *Sash-lift, Window-blind lift.*

Lift-latch, or sliding-door latch. Figs. 2558-78. A lock, the latch of which is lifted by turning the knob instead of drawing it backward.

Lift-latch lock. Fig. 2560, etc. "A lock in which the latch is pivoted and lifted free of the keeper, passing through a notch in the box instead of being simply retracted."—*Knight.*

Lignomur. A decorative head-lining made from straw-board or paper, with figures stamped or embossed upon it. The figures are usually light colored, while the background is darker. It is glued to a thin narrow matched ceiling or may be applied directly to an old veneered ceiling.

Limit gage. Figs. 5490-1. A term applied to many forms of gages which are used for determining whether pieces do not exceed or fall below a certain specified range of dimension. In 1893 limit gage, and diameters for round iron were adopted as a Recommended Practice; these had formerly been standard of the Association. Limit-gages, such as shown herewith for 1 $\frac{1}{4}$ -inch iron, are recommended for use in procuring round iron to take the

Seller's standard screw threads; round iron used to be of such size as will enter the large or + end of the gage intended for that size, in any way, and also of such size as will not enter the small or — end in any way.

The limiting diameters for certain nominal sizes of iron, together with the maximum variation allowable by such use of these gages, are given in the following table :

Sizes of Limit Gages for Round Iron.

Nominal diameter of iron. Inches.	Large size. + end. Inches.	Small size. — end. Inches.	Total variation. Inches.
$\frac{1}{4}$	2550	2450	.010
$\frac{3}{8}$	3180	3070	.011
$\frac{1}{2}$	3810	3690	.012
$\frac{3}{4}$	4440	4310	.013
$\frac{1}{2}$	5070	4930	.014
$\frac{3}{4}$	5700	5550	.015
$\frac{1}{2}$	6330	6170	.016
$\frac{3}{4}$	7585	7415	.017
$\frac{1}{2}$	8840	8660	.018
1.....	1,0095	9905	.019
1 $\frac{1}{4}$	1,1350	1,1150	.020
1 $\frac{1}{2}$	1,2605	1,2395	.021

Lincrusta-Walton. A decorative material for walls and ceilings, having something of the appearance and toughness of leather. It is made from the residuum of boiled linseed oil mixed with sawdust. Designs of any form are pressed upon it and it is furnished in a great variety of colors. It is attached to walls, generally with paste or glue, like wall-paper, but is water-proof and very flexible.

Line-car. Figs. 2, 9, 14. A short term to designate cars belonging to the various *fast-freight lines* which run over several roads between the leading shipping points east and west. The number of these lines is large, and at the present time they are nearly all owned by associations of the roads themselves and not by private individuals. Their object is to make it possible to issue through bills of lading and to avoid breaking bulk, as well as to obtain greater dispatch.

At the 17th M. C. B. Convention, Chicago, 1883, the following resolutions were adopted :

"Whereas, It is a common practice to store line cars on side tracks during summer months or dull times away from home, after they have been in severe service; and,

"Whereas, Many of the cars after being so stored are found to be more or less out of proper condition, so that they need more or less repairs, and when put into service cause much detention to traffic and many transfers;

"Be it resolved, therefore, That it is the sense of this meeting that all line cars owned by foreign companies should be returned to their owners instead of being stored on foreign tracks, and that a competent man should be detailed to inspect the stored cars and to arrange to have the necessary repairs made during the time such cars are out of service."

For standard lettering of line cars, figs. 5543-5, see *Lettering.*

Linen-closet lock. Figs. 2647-8.

Liner-blocks (Janney freight-coupler). 202, figs. 2161-82. Blocks of cast or malleable iron bolted to the top and bottom of the tail end of the coupler or drawbar.

Lining. See *End-lining, Head-lining, Inside-lining, Feed-door lining.* Inner, outer and intermediate linings of refrigerator cars are those linings or partitions intermediate between the *inside lining* and the sheathing, which usually consists of $\frac{1}{4}$ or $\frac{3}{8}$ stuff, whose purpose is to make dead air spaces for insulating the contents of the car.

Lining-strips. Wooden or metal strips put on the inside of freight or baggage-cars to protect the inside of the car from being injured by freight or baggage. Lining strips serve very much the same purpose as inside-lining.

Lining studs. 54, figs. 278-86. Vertical studs placed between the posts and over or under the braces, and to which the lining is nailed.

Link. 1. "A short connecting piece, of circular or other equivalent shape; as one of the oval rings or divisions of a chain."—*Knicht*.

2. (Coupling-links.) 2. Figs. 2073-4. A short bar with an eye at each end for connecting two things together or for supporting one from another. When used alone the term in railroad service always means a *coupling-link*, which see. See also *Brake-block suspending-link*. *Eccentric-lever link*. *Hanger-link*.

Link-and-pin coupler. An old type of drawbar by which cars were connected together by a *link* and a *pin*. There were a great variety of shapes and devices, but they are rapidly going into the scrap pile and being replaced by the M. C. B automatic coupler.

Link-hanger. 46, fig. 4745a. A *swing-hanger*, which see, in the form of a link.

Link-hanger eye-bolt. 47, fig. 4745a. A bolt passing through the transoms from which a very short *swing-hanger* is suspended.

Link-pin. A *coupling-pin*, which see. 3, fig. 2073.

Linoleum. A form of floor covering manufactured from linseed oil, prepared by a special process, mixed with ground cork and backed with canvas. Another floor covering of substantially the same nature as linoleum is known as *corticine*.

Lintel. 90 and 99, figs. 539-67. The horizontal part of a door or window-frame above the sash. See *Deck-sash lintel*.

Lip. See *Retaining-lip* (steel-tired wheels).

Lip lamp-chimney. Figs. 3414-15, 3419-21. One with an indented ring near the bottom, for use with screw lamp-burners.

Live-lever. 92, figs. 4580-2. The one of a pair of brake-levers to which the brake-power is first applied is sometimes given this title, the other lever being termed the *dead-lever*. 92a.

Loading poles, logs and bark on cars. Figs. 5573-6. In 1893 a Recommended Practice was adopted for loading logs and poles on cars and for racking cars for loading bark, as shown on Sheet B. The lines across the stakes indicate ties across the car.

Lock. 1. Figs. 2554-78, 2644-2772. "Anything that fastens—particularly an instrument having one or more bolts moved by a key, used for fastening doors, drawers, etc."— *Worcester*. Accordingly, in this dictionary, locks which have a bevelled bolt, especially if they do not require a key to move them, are termed *latches*, and those with a square-ended bolt, *locks*. See *Sash-lock* and *latch*. According to their purpose locks are divided into *berth-locks*, *door-locks*, *freight-car locks*, *grain-door locks*, *seal-locks*, *sliding-door* or *lift-latch locks*, etc. According to their manner of application, they are distinguished as *mortise locks*, inserted entirely within the door; *rabbeled locks*, visible on the exterior of the door, but boxed more or less into it; and *rim-locks*, entirely exterior to the door. A *dead-lock* is one which has no springs within it, but is moved entirely by key; in distinction from a *spring door-lock* or *night-latch*, which is moved by a key from without, but has a beveled bolt so that it snaps shut automatically. A *padlock* is one used with a staple and hasp, and which is not otherwise permanently attached to the opening which it fastens. The *Yale lock*, which see, is a special form largely used. Freight-car locks are usually *seal locks*. See *Car seal*. See also *Private lock* (English).

2. (Of an M. C. B. Automatic Coupler.) The catch which drops in front of the *knuckle-horn* and holds it shut, thus locking the couplers together.

Lock-case. 8, figs. 2766-7. The outside or covering part of a lock, more especially a padlock.

Lock-chain. Figs. 2766-7. A chain by which a padlock is fastened to a car.

Locker. A small compartment or closet for storage. A *closet* is usually the same height as the room and a

locker is of less height. Lockers are frequently attached under cars, as in figs. 105, 110, 118, etc. In street-car see 105, fig. 5654.

Locking-bar and plate. Figs. 1812-13, 1827-9. *American flush car-door*.

Lock-keeper. Figs. 2541, 2578, and 2644-2735. The box on a door-jamb into which the bolt of a lock protrudes when shut. See *Keeper*.

Lock-nut. The outer one of a pair of nuts on one bolt, which, by screwing up separately to a tight bearing, locks the inner one.

Lock-seal. Fig. 3897. A piece of glass, lead or paper, which forms a seal for a lock, so that the latter cannot be opened without its being known. See *Car-seal*.

Locomotive crane. Figs. 209-11, 389-91. A self-propelling car, with a steam crane, mounted upon it, which crane has three independent motions, viz.: that of hoisting, slewing or rotating and raising of the boom. They are not often made of more than 15 or 20 tons capacity.

Lodging-car. A passenger or box-car fitted up with sleeping accommodations for men at work on the line of a road. More commonly called *boarding-car*.

Logging-cars. Figs. 34-6, 352-4. A special variety of light and strong cars used for getting out lumber, running usually on cheap *logging railroads*, of which a great number now exist.

Long brake-rod (Stevens brake.) 12, fig. 1461. A rod which connects two levers, one on each truck, together.

Long brake-shaft. 94, figs. 229-66. One which extends up above the top of a car so that brakes can be applied by a person on the roof.

Long center-buffing-spring. Fig. 1402. See *Buffer-spring*.

Long flat-car. Fig. 19. A flat-car of extra length for long timbers, piling, etc. A barrel-car is an example, shown racked in fig. 15.

Long gondola-car. Figs. 26, 310-20. See *Gondola-car*.

Longitudinal rising-timber. 110, figs. 328-31. See *Rising-timber*.

Longitudinal-seat (street and suburban cars). Figs. 99, 3945-47, 5654-6. A seat which extends lengthwise of a car.

Longitudinal-step. 1. Figs. 151, 5647-9, 75, fig. 5659. A board which extends along the side of an open car, or a car with doors on the side, used as a step in getting on or off the car or for passing from one end of the car to the other.

2. (English.) See *Foot-board*.

Longitudinal-step bracket. A bracket to carry a *longitudinal-step*. See above.

Longitudinal tie-rod (English). 9, figs. 349 and 502. Corresponds in part to an American *truss-rod*. A long bolt binding the timbers of the *underframe* together longitudinally. It is generally horizontal, and if inclined slopes downward to the ends of the vehicle to prevent them sagging or drooping. In English eight-wheeled vehicles *truss-rods* are used, but in four-wheeled vehicles the ends are more likely to sag than the center.

Long seat-end. Fig. 3995. A vertical frame of wood or (usually) iron which combines a *seat-end* and *seat-stand* together, supports the end of the car-seat and also forms the arm or seat-end. A *short seat-end* is a seat-end proper, which is supported on a separate stand.

Long T-bolt (Janney equipment). A bolt by which the *combination-yoke* acts against the *center buffer-spring*.

Lookout (freight caboose). Figs. 5054, 380-8. A small cupola or upper deck in the roof to afford opportunity for the display of signal-lights and to enable train hands to keep a better lookout on the train. They are in very general use.

Loose berth-hinge. Figs. 4183-6. A berth-hinge the two parts of which are detachable. It enters into a *loose berth-hinge bushing*, fig. 4187 or *Plates* 4183 and 4185. See *Berth-hinge*.

Loose-globe. See *Lamp-globe*.

Loose-globe lamp. A lamp or lantern in which the globe is attached to the frame by springs, screws or catches, so that it can be easily removed.

Loose-joint butt-hinge. Figs. 2591-2. A *butt-hinge*, which see, permitting the door to be lifted off its hinges when desired.

Loose-pin butt-hinge. Fig. 2598. A *butt-hinge*, which see, having a removable *hinge-pin*.

Loose-wheel. A term applied to various devices for enabling the two car-wheels on the same axle to revolve independently of each other. Many of these devices have been patented, but none of them are in general use. Experiment seems to indicate that the advantages are more theoretical than practical. See especially a series of tests by Reuben Wells in the transactions of the Master Car-Builders' Association, 1870.

Lorry, or larry. Figs. 5583, 5589, 5603-4. *Push-cars* used in construction for moving rails, ties, etc. Often made with only a half bearing for the journals so that the frame can be removed from the wheels at any time.

Lower-air-cylinder gasket (air pump). 39, fig. 1689; 104, figs. 1691-2.

Lower arch-bar. The *inverted arch-bar*. See *Arch-bar*.

Lower-berth (sleeping cars). 1, figs. 2409-12. The bed nearest the floor made up by pulling out the seats and dropping down the seat-backs. The mattress for it is carried by day in the pocket formed by the upper berth. In the Mann boudoir cars, figs. 2418, the lower-berth intact forms a sofa by day, the sofa-back forming the upper berth. See *Berth*.

Lower-berth curtains. (Mann boudoir cars.) 13, figs. 2418. Lower-berth curtains are also used in the Pullman and Wagner sleeping-cars, being hung upon a cord stretched across the edge of the bunk. See *Berth-curtain*.

Lower-berth stop-bar. 49, fig. 2409. See *Stop-bar*.

Lower bolster-plate. 12b, figs. 435-73. Should read *Body-bolster bottom-plate*. See *Body-bolster*.

Lower brake-rod. 97, figs. 4740, 4806-4966. A rod which connects the two break-beams or levers of *outer-hung* brakes. When two levers are used the rod is attached to each lever. It is sometimes supported in case of accident by a *lower brake-rod carrier*. With *inner-hung* brakes the substitute for the lower brake-rod becomes a part in compression and is called the *brake-lever coupling-bar*. 93, fig. 4581.

Lower brake-shaft bearing. 97, figs. 229-66. An eye or support for a vertical brake-shaft, near the lower end. The support at the lower end is called the *brake-shaft step*. The lower bearing is above the step.

Lower-cap (plain triple valve for Westinghouse brake). 3, figs. 1708-9. (Of reducing-valve. Westinghouse train signal apparatus.) 3, fig. 2406.

Lower-chord (of a truss). The lower outside member. In the side trussing of a freight or passenger car the *side-sill* is the *lower-chord*.

(The distinction between a lower chord and a truss-rod is not very clear. A *chord* is usually so called only in a truss having both vertical and inclined members. A mere *trussed-beam* is not a truss in modern technical usage.)

Lower corner-plate. 57, figs. 229-66. See *Corner-plate*. A *push-block*, or push-pole corner-iron, is usually the lower corner-plate. 191, figs. 229-66.

Lower or bottom cylinder-head (Westinghouse driving-wheel brake-cylinder). 4, figs. 1748.

Lower-deck. 102, figs. 539-41. The main roof of a passenger-car on each side of the *clear-story* or *upper-deck*.

Lower discharge-valve (air-pump air-brake). 32, figs. 1689. A *puppet-valve*, which see, at the bottom of the air-pump through which the air below the piston escapes.

Lower door-hinge (English). 180, fig. 501. See *Door-hinge*. This hinge is made with a longer butt than the others, to allow for the curvature or *fall-under* of the door.

Lower door-panel. 10, figs. 1783-93.

Lower door-sash. 13, fig. 1788. The lower section of a door-sash, which is made in two parts. This is commonly movable, the other fixed.

Lower end-panel (street cars). 46, figs. 5654-67.

Lower foot-board (English). 171, figs. 501-4. American equivalent, *platform-step*. A board running nearly the whole length of the carriage, and situated about 20 in. from the ground.

Lower-head (air pump). 64, figs. 1691-2. The *air-cylinder head*, which see.

Lower outside-panel (street cars). 46, figs. 5654-67. It is usually made concave.

Lower receiving valve (air pump). 33, fig. 1689.

Lower seat-back rail (street cars). 111, figs. 5654-67. Also called a *seat-back bottom-rail*. See *Upper seat-back rail*.

Lower side-bearing (logging cars). Figs. 352-4. The *truck side-bearing*.

Lower steam-valve (Westinghouse air-pump). 7, Figs. 1689. See *Main steam-valve*.

Lower swing-hanger pivot. 48, figs. 4580-4805. A bar by which a *spring-plank* is attached to the lower end of a *swing-hanger*, which see.

Lower valve-chamber cap (air-pump). 34, fig. 1689.

Lower wainscot-rail (passenger-car interiors). 74, figs. 435-72, 539-41. A longitudinal rail immediately above the truss-plank. The *upper wainscot-rail* comes directly below the window.

Lower window-blind. 140, figs. 539-41. The lower section of a window-blind which is made in two parts, as is usually the case.

Lower window-blind lift. Figs. 4435-7, and 4445-7. The lifts for lower blinds differ from those for a single blind in having a lug which engages with the upper blind when the lower one is raised up halfway, and thus the upper one is raised with the lower one. See *Window-blind lift*.

Low-sided wagon (English). A freight-car with sides and ends about 9 in. high. It has generally no doors and is used chiefly for conveying pig-iron and similar loads. See *High-sided wagon*. *Medium-sided wagon*.

Low truck. Trucks constructed so as to bring the floor nearer to the rails; mainly used in construction service. They are commonly constructed so as to bring the floor about 3 ft. 2 to 6 in. from the rail instead of about 4 ft.

Lubricator. Fig. 1757. An instrument used for applying a lubricant. Also called *oiler*. See *Automatic lubricator*.

Lug. 1. A projecting stud or ear to afford a bearing or point of attachment. See *follower-plate lug*.
2. (Bolster-springs.) Figs. 5201-22. Projecting points upon the *spring-plates* to enter the timber.
3. (Head-board.) Fig. 4167.

Lug-bolt. Fig. 3712. A *strap-bolt*, which see, with a lug turned up at one end to enter a mortise in the timber and in part relieve the attaching bolts from strain.

Lumber. Timber of all kinds sawed into merchantable form, but more particularly such as is not sawed into boards. The term, however, is often used in the broad sense.

Lumber-car. Figs. 19, 294-7. 1. A car of extra length, sometimes 40 ft. long, more particularly intended for carrying long timbers. Box and stock-cars frequently have end-doors to facilitate the loading of lumber. Gondola-cars, with flat bottoms and drop doors, are largely used for lumber.

Lumber lorry. See *Lorry-car*.

M

McElroy Commingler System. (Consolidated Car-heating Co.) This system depends upon the direct action of the steam upon the water of circulation, caused by the steam

discharging within the body of the water itself. The contact of the steam and water takes place within the pear-shaped body of the commingler, a sectional view of which is shown in Fig. 2970. The flow of steam is broken into small jets within a body of quartz pebbles, to destroy the noise and to silently force the water through the commingler. The steam jets give a forced as well as a gravity circulation, which feature of forced circulation enables the commingler to move the water through large circuits. The heating system is kept constantly filled from the condensation which takes place within the commingler, and the water in the expansion-drum kept level with the top of the overflow-pipe. It is claimed that five lbs. steam-pressure in the train-pipe at the car is sufficient to heat a car in the coldest weather.

McElroy commingler storage-system (Consolidated Car-heating). Fig. 2973. A system of heating in which a small commingler is placed under the center of the car and so arranged that when the car is not in use there is no water in the system. In heating up a car the heating is accomplished by forcing live steam into the pipes and the water of condensation that collects is circulated by the commingler through the pipes, thus automatically operating as a hot water circulating system whose temperature may be run high or low, depending upon the amount of inflowing steam. On laying off a car a valve is turned and the water of circulation allowed to drain to the ground.

McElroy steam hose-coupler (Consolidated Car-heating). Figs. 2985-9. A steam hose-coupling used for connecting train-pipes between the cars. Its important feature is in presenting a straight-port and having a construction in which gaskets do not rotate on each other in the act of coupling or uncoupling. Its construction is shown in the figures.

McGuire grain-door. Fig. 1876-95. A grain-door fastened to a *grain-door rod* by a U-strap or *arm* and hung to the carlines when not in use by an *Overhead door catch*. The door post is protected by a *Door-post angle-iron*. The door is held in place by a *door-keeper*, **G**, and a *Button head*, **L**, and the corners are shod with a *shoe*, **N**.

McKay's curtain brackets. Figs. 4567, 4574-5. A form of bracket for holding the various forms of spring roller curtains, one bracket having a rectangular hole and the other a circular. A variety of patterns are made besides those shown. The McKay and Hartshorn *shade roller* accomplish the same end in much the same way, but the McKay works with a cam, while the Hartshorn works with a pawl. See *Shade-roller*.

McKee-Fuller Company's steel-tired car-wheels. Figs. 5306-7a.

Machine-bolt. Figs. 3708-9. A bolt with a metal thread cut on it, and with a square or hexagonal head, especially if turned or finished. The word *bolt*, unqualified, usually means a machine-bolt.

Magazine (base burning stoves). A general term for a receptacle for coal before it reaches the fire-pot proper, usually situated directly above the latter.

Magnetic curtain-holder. A device for holding a window-shade fixed in any position, while still leaving it easily movable. It consists simply of a bar magnet running across the lower edge of the shade, bearing against two fixed bars of soft iron, one on each side of the window, to which the magnets attach themselves.

Mail-car. A car for carrying mails. More properly a *postal-car*. Figs. 142-8, 599-615. Mail-cars are sometimes defined as those used only for carrying mail-bags and not for distributing mail-matter, but the distinction is not always observed. Distributing mail-cars are, however, always called *postal-cars*, which see. See also *Combination baggage-car*.

Mail-car lamp. Figs. 3266, 3273, 3289-90. See *Postal-car lamp*.

Mail-catcher or collector. Figs. 142, 3819. **13**, fig. 600.

A contrivance consisting of a bent iron bar, attached to the door of a postal car for taking up or "catching" mail-bags while the train is in motion. The English system of collecting mail-bags is different from the American, and relies upon the use of nets. The leather bag is fastened by a spring to an iron bar in the car and when the exchanging station is near the bar is turned out, the bag hanging suspended. At the same time, the catching apparatus, consisting of a net attached to a bar, is put out. The bag from the car is caught in a net attached to a stationary post and the bag for the car caught in the car net in a similar manner. The American plan has been copied in Australia and India.

Mail-catcher socket or mail-collector socket. **14**, figs. 599-604. The brackets or sockets on either side of the postal-door which hold the collector.

Mail-van (English). A vehicle adapted to run on passenger trains and fitted with apparatus for sorting and conveying letters, and generally with apparatus for taking up and dropping mail-bags while the train is at full speed. A mail-van in which letters can be posted and letters are postmarked is termed a *traveling post-office*. When fitted only for conveying mail-bags and not for sorting, it is termed *mail-van tender*. Every projecting piece of either wood or metal is carefully padded to prevent injury to the post-office officials in collisions, etc.

Main-carline (freight-cars). **82**, figs. 229-66. A carline stronger than the ordinary carlines, so as to support the roof and tie the two *plates* together.

Main-cock (Pintsch gas-lighting). Figs. 3169, 3234. A cock usually placed in the saloon for the control of the low-pressure supply. It regulates all the burners at once, in addition to which there are separate cocks to each. **25**, **25b**, **25c** fig. 3169, are respectively for $\frac{1}{4}$ in., $\frac{3}{8}$ in. and $\frac{1}{2}$ in. pipe, and are used in all classes of cars according to size of main low-pressure pipe required. **25c** ($\frac{1}{2}$ in.), is in most general use. This cock is handled with *key* **46**, fig. 3215.

Main-cock. (Pintsch system.) **22**, fig. 3234. A $\frac{1}{4}$ in. tee-handle cock for postal or express cars.

Main-cock covers (Pintsch system). No. 135, 135C, fig. 3170. For main cocks, No. 25, 25B, 25C, fig. 3169. They are of cast-iron, with hinged lid to fit over key-shaft of cock. Are to be screwed to side of car or to bulk-head.

Main draft-spring (Janney). So called in distinction from the *auxiliary draft-spring*. The *center buffer-spring* lies above both.

Main-pipe (air-brake). **16**, figs. 1693-8. The *brake-pipe*.

Main piston-valve (air-pump). **76**, figs. 1691-2.

Main-rafter. A *main-carline*, which see.

Main-reservoir (air-brake). **1**, figs. 1699-1707. A cylindrical boiler-plate tank, carried on the locomotive, under the foot-board, to hold a supply of compressed air. So called in distinction from the *auxiliary reservoirs* under each car.

Main-sheave (pile-driver car). **10**, figs. 403-4. The sheave at the top of the leaders over which the *hoisting-rope* passes.

Main slide-valve (air-pump). **83**, figs. 1691-2.

Main steam casting (consolidated car-heating). Fig. 2972. A casting connected into the train pipe and provided with side ports, not connected to the train pipe ports, but connected to a drip port through which water drops to the ground. The return pipe from the heating apparatus is connected into these side ports from one or from both sides of the car. The pipe leading to the casting is heated by the train pipe and the casting prevents the drip from freezing.

Main steam-valves (Westinghouse air-pump). **7**, fig. 1689. Two piston valves admitting and exhausting

- steam above and below the main piston. The upper is of larger diameter than the lower, both being rigidly connected by a rod, so that the pressure of steam (always between them) keeps them in the highest position, admitting steam above the main piston and exhausting from beneath it. At the end of the stroke they are moved downward by steam being admitted above the *reversing piston* by the *reversing valve*, 16, which see. They are usually called simply *main-valves*.
- Main-valve, upper and lower.** (Westinghouse air-pump, etc.) 7, fig. 1689. The *main steam-valves*, which see.
- Main-valve bush, upper and lower** (air-pump). 25, 26, fig. 1689.
- Main-valve packing-rings, upper and lower** (air-pump). 8, 9, fig. 1689.
- Main-valve stem** (air pump). 81, figs. 1691-2.
- Main-valve stop** (air-pump). 50, fig. 1689.
- Male center-plate.** The body and truck center-plates are sometimes called male and female. See *Center-plate*.
- Malleable iron.** Castings whose brittleness has been removed by packing them in powdered hematite (peroxide of iron) in tight fire-brick cases and subjecting them to a continued red heat for about a week. They are then allowed to cool slowly. The oxygen of the hematite combines with and removes a part of the carbon of the iron, making the castings almost as tough as wrought iron, but they are ordinarily not truly malleable, or capable of being rolled or forged. Malleable iron is much used for pipe fittings and similar small castings, and even for brake-shoes.
- Mammoth lamp-chimney.** Fig. 3417. See *Lamp-chimney*.
- Mandrel.** 1. (For lathes.) A shaft serving as a temporary axis for objects to be turned.
2. (Foundry.) A plug around which a body of metal is cast.
- Mandrel-pin, or cross-bar** (swing link-hanger). 44, figs. 4580-4805 and 4806-4966. The bar which supports the spring-plank. See *Swing-hanger*.
- Manhattan center-draft drawbar.** Figs. 2288-9a. See *Center-draft drawbar*.
- Man-hole.** 110, figs. 373-9. An opening in a boiler or tank through which a man can creep to the inside. The tanks for tank-cars always have man-holes on top.
- Man-hole cover.** 111, figs. 373-6. A plate or lid to close a man-hole.
- Man-hole cover chain.** A chain with which a man-hole cover is fastened to a tank to prevent it from falling off the tank when the man-hole is opened.
- Man-hole hinge.** 113, figs. 373-6. A hinge by which a man-hole cover is attached to man-hole ring.
- Man-hole ring.** A metal ring riveted around a man-hole, and which forms a seat for the cover.
- Mann "boudoir" sleeping-cars.** Figs. 205, 2418. A style of sleeper the distinguishing feature of which is the subdivision of the car into small state-rooms or "boudoir" running transversely of the car, and all opening into a common *corridor* at one side of the car. These cars were for a time the only sleeping cars in Europe, and were introduced in this country in about 1883, the first cars having been run between Boston and New York. There are only a few in service now in this country and no more are being built. They are being replaced by *Compartment-sleepers*, as shown in figs. 123, 176 and 187. The roof of figs. 95 and 96 are like those of the original *Mann boudoir-car*.
- Mansfield deck-sash opener.** Figs. 1625-6. One of the numerous styles of deck-sash openers, the peculiarity in which consists in the manner of connecting each end of each deck-sash to an opener in such manner that either the front end or the back end of the window may be thrown open, producing draft either into or out of the car at discretion.
- Mansell retaining ring.** Figs. 5261, 5339-40, 5347. A mode of connecting steel tires to the wheel-centers by a ring of an approximate L or U cross-section, which secures the tire to the wheel, so that every part of the tire is securely held, into however many pieces it may be ruptured. This ring is almost universally used in English passenger service. Various applications of the ring are shown in the figures.
- Mansell wheel** (English). Figs. 5320, 5347. A railroad wheel in which the hub is composed of two wrought or cast-iron rings bolted together, and gripping the ends of contiguous tapered teak blocks which serve as spokes, and are secured to the tire by two rings fitting into grooves in the tire, and bolted to the teak blocks. This wheel is almost universally used in English passenger service.
- Marden's brake-beam.** Fig. 1600. A brake-beam, brake-head and clamp, patented by A. H. Marden, of Charlestown, Mass. The beam is a steel deck-beam. The malleable iron head is adapted to several forms of shoes, and is fastened to the beam by a slot in the lower edge of the T-flange. The brake-beam, with its attachments complete, weighs 87 pounds.
- Marking** (cars). In 1893 a Recommended Practice was adopted as follows: That all railroad companies having the same initials as other railroad companies should stencil the name of the road in full on some part of the car where it may be readily seen. See *Lettering*.
- Marshaling** (English). American equivalent, *switching* or *drilling*. Arranging the cars of a freight train in proper station order.
- Mast.** 1. (Of a derrick or crane.) 4, fig. 392. The main upright member against which the boom abuts.
2. (Of brake-gear.) A *brake-shaft*, which see.
- M. C. B. Reports.**—In 1893 a standard size of 6 inches by 9 inches was adopted for M. C. B. reports.
In 1894 a standard size for Pamphlets, Catalogues, Specifications and publications of that nature were adopted, as follows:
- For postal-card circulars, 3½ inches by 6¼ inches.
- For pamphlets and trade catalogues $\left\{ \begin{array}{l} 3\frac{1}{2} \text{ in. by } 6 \text{ in.} \\ 6 \text{ in. by } 9 \text{ in.} \\ 9 \text{ in. by } 12 \text{ in.} \end{array} \right.$
- For specifications and letter paper, 8½ inches by 10½ inches. In connection with these standards it was decided that a standard practice should be to have the proper standard dimensions, and the word "standard" printed on the upper left-hand corner of title-page or cover whenever practicable.
- Master car-builders' standards and Recommended Practice.** A variety of standard details for cars, or recommendations in respect to them, which have been adopted and promulgated by the Master Car-Builders' Association, and are separately described in this volume. By a letter-ballot, cast in 1893, the standards of the Association prevailing at that date were modified—
- First.*—By abolishing certain standards because they had either become obsolete or nearly so, or because they were simply forms of gages for shop use to produce certain other standard forms, and it was believed that such gages were not essential as standards of the Association, and it had been ascertained that they were not generally used.
- The old standards thus abolished were:
- Wheel-diameter testing-gage.
 - Wheel-flange and journal gage.
 - Wheel-bore testing-gage.
 - Wheel-boring, use of six dogs.
 - Journal-length and diameter-gage.
 - Journal-shoulder and centering-gage.
 - Journal-distance gage.
 - Guard-rail gage. (Made standard again in 1894.)
 - Attachments and dimensions of drawbars.
 - Train-pipe fitting for steam heat.

Second.—By ordering that the three items formerly printed at the end of the standards, namely :

Storage of line-cars on foreign roads,
Dictionary of terms,
Entertainments,

be printed with the proceedings as heretofore, but not among the standards.

Third.—By dividing the remaining standards into :

(a) Standards of the Association.

(b) Recommended Practice, as follows :

a. Standards :

Air-brakes, general arrangement and details. Figs. 5433-4, etc.

Automatic-coupler. Figs. 5499-5505.

Axles. Figs. 5419-21.

Brake-beam data. Fig. 5432.

Brake-gear, for freight-cars. Figs. 5433-41.

Brake-gear, foundation. Figs. 5442-83.

Brakehead, shoe and key. Figs. 5425-31.

Bolts-and-nuts, dimensions for. Figs. 5490-8.

Check gage for mounting wheels. Fig. 5486.

Drawbar, height of

Flange-distance gage (inside to inside). Figs. 5421, 5486.

Guard-rail and frog-wing gage. Figs. 5484-5.

Journal-bearings and key. Figs. 5389-5418.

Journal-box and details. Figs. 5377-88,

Journal-box lid. Figs. 5402-5.

Knuckle, contour line of and gages. Figs. 5499-5501.

M. C.-B. Reports, Proceedings, etc.

Pedestal. Figs. 5480-83.

Screw-threads. Fig. 5498.

Wedge, journal-box. Figs. 5389-5418.

Wheel and track, terms and gaging points. Fig. 5485.

Wheel-circumference measure. Figs. 5422-4.

Wheel distance gages, between flanges. Figs. 5421, 5486.

Wheel-flange (max. and min. thickness). Figs. 5488-9.

Wheel-tread and flange. Fig. 5487.

Recommended Practice :

Air-brake cut-out and defect card. Figs. 5577-8.

Air-brake repair-card. Figs. 5577-8.

Brake-shaft and brake-step. Figs. 5546-7.

Buffer-blocks. Figs. 5548-51.

Check-chains.

Draft-springs, capacity of.

Drawbar attachments and dimensions. Figs. 5507-37.

Dummy coupling-hook. Figs. 5579-80.

Interchange of Traffic, rules for.

Journal-bearing and wedge-gage. Figs. 5556-71.

Ladder and grab-iron attachment. Figs. 5546-7.

Lettering for line cars. Figs. 5543-5.

Limit gages for round-iron. Figs. 5490-1.

Line-cars, storage of.

Loading bark, poles, etc. Figs. 5572-6.

Marking of cars.

Rules of Interchange.

Running-boards. Figs. 5546-7.

Safety-chains, freight-cars. Figs. 5552-5.

Safety-chains, platform. Fig. 5539.

Steel-tire, minimum thickness. Fig. 5489.

These Standards and this Recommended Practice are given under their respective heads in these pages as modified by letter ballot on these or other subjects, and revised by the ballot of 1894.

New drawings of the Standards and Recommended Practice have been made on sheets of uniform size, and lithographed and printed on transparent paper so that blue prints may be taken from them ; such sheets are for sale by the Secretary of the M. C. B. Association in connection with pamphlets containing explanatory text as given in the Proceedings. See *Standards. Recommended Practice.*

Master-key. " A key which commands many locks of a certain set, the keys of which are not interchangeable

among themselves. While neither one of a series of keys may suffice to open any lock, besides the one for which it is constructed, a master-key is one which may operate any one of the set."—*Knight.*

Mast-pocket (wrecking-car). A heavy casting under the car supported by a *derrick truss-rod* serving as a socket for supporting the mast of a derrick to hold it upright. Another method of supporting the mast is by a large *base-plate*, bolted to the floor of the car.

Mast-sheave or pulley (of a derrick or crane). 21, figs. 392-3. A sheave or pulley-wheel placed at the top of the mast.

Mat. Figs. 2856-7. See *Floor-mat.*

Match-box holder. Fig. 4280. (Which is shown *bottom-end-up*).

Match-lighter. Figs. 4284-5. A *match-striker*, which see.

Match-safe. Fig. 4281.

Match-striker. Fig. 4284-5. A metal plate with a rough surface.

Match-striker frame. A metal frame for holding a piece of sand or emery-paper.

Matting. See *Cocoa matting.*

Mattress (sleeping-cars). Figs. 2408-12. **D, E,** fig. 2418. In ordinary sleeping-cars both mattresses are stowed away by day above the upper berth. In the boudoir-cars they go in boxes under the seats.

Mattress-box (Mann boudoir cars). **J,** figs. 2418. See above.

Meat timbers (refrigerator-car). The vertical and horizontal timbers inside the refrigerating chamber on which the meat is suspended. They are usually independent of the framework of the car and fastened to it with coach-screws.

Medium-sided wagon (English). Figs. 348-51. American equivalent, *four-wheeled gondola-car.* A vehicle for freight service, with sides and ends about thirty inches high, and no roof. The doors are generally arranged as shown, but often extend the whole depth, and sometimes the whole length and depth of the side. About half of all the freight-cars in England are of this variety, a *tarpaulin*, which see, being used to protect the freight from the weather.

Meehan brake-shoe. Fig. 1648. The Meehan brake-shoe is solely for use upon steel-tired and cast-iron wheels. It is a cast shoe with crucible steel slugs cast in it so that they bear upon the surface. The steel slugs are in the flange and on the outside edge of the wearing surface of the shoe, thereby wearing the wheel-tread with the hard steel slugs where the rail does not come in contact with the wheel. The principle has proven to be very advantageous. See *Ross-Meehan brake-shoe.* Figs. 1646-54.

Meehan-Shepard brake-shoe. Fig. 1659. A shoe used entirely on bald or blind-tire wheels. Lips are cast on the side of the shoe, as shown in section Fig. 1653, lapping over the outside of the wheel and holding the shoe in place. Steel slugs are inserted in the shoe each side of the center. This shoe has the Ross feature when it is used, namely, the hollowed center. The Fig. 1659 is not strictly a Meehan-Shepard brake-shoe, for it has not the lips on either side to lap over the edge of the wheel.

Melon-shaped lamp-globe. Fig. 3431. See *Lamp-globe.*

Meneeley roller-bearings. Figs. 5680-1. A roller-bearing which consists of a cast-iron housing, lined with plate steel, inside of which and surrounding the journal are three sets of weldless steel-tubes or cylindrical rollers. The rollers of each set are of equal length, and are placed in a ring about the journal, forming three independent rings or groups of roller-bearings. The middle set is then revolved until the axis of each roller is midway between the axes of the inner and outer sets of rollers, the axes of the latter being in a straight line. Cold-rolled steel rods, called separators, are then passed

through the hollow rollers, coupling the middle ring of rollers to the outside rings each to each, which insures their keeping in line and working together. See figures 5680-1. A malleable-iron cap or lid with a brass-bearing abuts against the end of the axle to take up the end thrust.

They are in use on electric-motor cars and increasing in favor. A train has been equipped with them on the Delaware & Hudson Canal Company and favorable results obtained. One car has been in service for some time on the Boston & Albany Railroad. See *Roller-bearings*.

Mercurial check-valve. (Frost system of gas lighting.) Figs. 3119-3120. The *bowl*, 1, of this valve is filled with mercury up to the height of the *set-screw*, 5, in the side. The air from the regulator enters the valve at the bottom and flows through the inverted U *air-pipe*, 4, issuing from the bottom end of this pipe, which is one inch below the surface of the mercury, rises up through the mercury into the chamber of the valve and thence to the *carburetors* by means of the *roof-pipe*. If, at any time, the pressure is withdrawn from the inlet end of this valve while there is pressure remaining in the carburetors, this remaining pressure acts upon the surface of the mercury in the valve and forces the mercury up into the U *air-pipe* to a height corresponding to the pressure. It is, however, impossible for the mercury to be forced to such a height that it flows over and down into the regulator for the reason that before sufficient pressure could be accumulated to act thus upon the mercury, the pressure is relieved by means of the *Mercurial safety-valve*. See below.

Mercurial safety-valve. (Frost system of gas lighting.) Fig. 3124. This *valve* is filled with mercury up to the *set-screw*, 8, in the side of the chamber and is connected by means of a pipe leading to the pressure chamber with the *roof-pipe* at some convenient point. It will then be seen that whatever pressure is in the carburetors and roof-pipe will be transmitted to the surface of the mercury in the *pressure-chamber*, 1, of this valve. The distance from the *set-screw* in the side of the chamber to the top of the *return-bend* is ten inches. Therefore, as the pressure in the *carburetors* increases, the surface of the mercury in the pressure chamber of this valve will be depressed until the pressure reaches five pounds, at which time the mercury will be blown out of the relief pipe, thus freeing the gas, which will find its way past the *deflector*, 10, and out through the cap to the atmosphere. The *deflector* catches the mercury, and, as soon as the pressure has been reduced below five pounds, the mercury flows back into the lower part of the *valve* and stops the further escape of gas.

Metal screw-thread. A form of screw-thread used when both the male and female screws are made of metal. Metal threads are made of the same size as the spaces between them, whereas the spaces between wood screw-threads are made wider than the projections. See figs. 5492-3. See also *Sellers system of screw-threads*.

Metal-seal. Figs. 3387-92. See *Car-seal*.

Mica chimney. (Pintsch system.) 109, fig. 3199. A chimney for use on all center lamps, being placed immediately above the ring reflector, allowing a portion of the light to be directed towards the roof of the car. See figs. 3238-39, 3242, and *Pintsch lamps*.

Micrometer gage. A general term for any form of gage giving very minute and exact measurements. There are several varieties; the most common is one with an accurate screw-thread and an index to give the number of revolutions and fractions thereof.

Middle corner-plate. 56, figs. 229-66. See *Corner-plate*.

Middle door-panel. 11, figs. 1788, etc. See *Door-panel*.

Middle door-rail. 148, figs. 435-73; 6, fig. 1788. A horizontal bar intermediate between the top and bottom rails. See *Door-frame*.

Middle longitudinal. (English.) 5, figs. 348-51, 501-4. American equivalent, *intermediate sill*. A part of the *underframing* supporting the body or floor, and in many cases transmitting the buffing and the draft strains.

Middle of axle. The portion of a car-axle between the two sloping *necks* which come next to the *wheel-seat*. See *Axle*, *Car-axle*.

Middle safety-beam (six-wheel trucks). 52, figs. 4957-66. A beam attached to the two transoms to hold the center axle in case of breakage.

Middle-transoms (six-wheel trucks). 21, fig. 4957-66. The two cross-pieces nearest the center in distinction from the two outside transoms. They are sometimes made of iron to allow the two swinging *spring-beams* to be connected to each other by the *bolster-bridge*.

Milk-car. Figs. 267-73. A car for carrying milk in cans, usually built with platforms similar to baggage cars, and equipped with passenger-car trucks. They are usually provided with tight-doors, ice racks or boxes, and insulation.

Miller coupler-buffer and platform. Figs. 2290-5. An arrangement for coupling cars automatically. It operates in coupling by the beveled faces of the *hooks* pushing each other to one side, compressing the center buffers at the same time, until they snap past and engage with each other, in which position they are held by a *leaf-spring* or *coupling-spring*, sometimes also called side-spring. On sharp curves the hooks sometimes disengage from each other, and the fact that this is unusual with the Janney couplers (which see) is one of the advantages claimed for it. The Miller coupler has been in extended use on American passenger-cars, but is now giving way to the M. C. B. form, which is a modified form of the Janney. The patents on the device have expired. A *Janney-Miller coupler*, which see, has been introduced by the manufacturers of the Janney coupler, in order to enable the latter to be used with rolling stock equipped with the Miller. The platform is arranged so that the line of draft and the compressive strains on the car are in a direct line with the sills.

Miller buffer. See *Janney-Miller coupler*.

Miller buffer-guide. See *Janney-Miller coupler*.

Miller buffer-yoke. See *Janney-Miller coupler*.

Miller combination-hook. See *Janney-Miller coupler*. The hook used to convert the Janney coupler to the Miller.

Miller stop. See *Janney-Miller coupler*.

Miller stop-bolt. See *Janney-Miller coupler*.

Mine-and-tunnel velocipedes. Figs. 5617-19. A light *Velocipede-car*, usually with four wheels, made specially for underground service.

Mine-car. Figs. 29-33 and 343-7. A small car for carrying minerals in mines, usually four-wheeled, and provided with a dumping device by which the load may be quickly and completely discharged.

Mineral wool. A substance having much the appearance which its name implies, manufactured from the slag of iron furnaces by throwing against it while in the molten state a strong blast of air. It is used for *deadening* in passenger-cars and also largely as a non-conductor for coating steam-pipes and boilers.

Minot heating-burner. Fig. 3397. See *Heating-burner*.

Mirror (for wash-rooms of sleeping-cars). 7, fig. 3468. A looking-glass.

Mirror-frame. Figs. 3653, 3657-8. A frame for a looking-glass.

Mirror-frame spring. A *Mirror-sash holder*.

Mirror-guard (wash-rooms, etc., of sleeping-cars). A fender of various forms to protect mirrors. Usually nickel-plated bars across the face, and a tray for towels or brush and comb at the bottom of the mirror.

Mirror-panel. (Mann boudoir cars.) 3, fig. 2418. A panel above the central window of four-place boudoirs, filled by a mirror.

Mirror-sash. A frame of a mirror which covers a *lamp-alcove* in the side of a car. It slides up and down like a window-sash.

Miscellaneous furnishings. Figs. 3578-3770.

Miscellaneous types freight-car trucks. Figs. 4747-60.
See *Diamond truck*.

Moehring argand burner. Fig. 3371. See *Argand burner*.
Mold. See *Chill-mold*.

Molding. 1. "A mode of ornamentation by grooved or swelling bands or forms, following the line of the object."—*Knight*. Small moldings are often termed *beads*, and also *fillets*. A *cove* molding is one of concave section. There are a great variety of other special technical terms for different forms of moldings. Moldings are either straight or *waved*, which see.

See also *Deck eaves-molding*. *Window cove-molding*.
Eaves-molding. *Window-molding*.
Platform hood-molding. *Widow-sill molding*.

2. (For car-seats.) Figs. 4023-8. Also called *Seat-back bands* or *seat-molding*. A metal band to finish the edge of the seat-back. Plush or leather-covered strips are also used.

Molding-joint cover. A piece of wood or metal in some ornamental form for covering the joints of two pieces of molding. See *Window-molding joint cover*.

"**Monarch**" burner. Fig. 3376. A double-spring burner.

Monitor deck-sash pivot and ratchet catch. Figs. 4397-8. A device for regulating the opening of deck-sashes by means of a small fixed *ratchet-plate* in which a *ratchet-bolt* engages, holding the sash fixed in any one of four different positions. See *Deck-sash pivot*.

Monitor-top. A *clear story*, or *upper deck*, which see.

Moore car-door. Figs. 1863-5. A box-car door, which by the bevel-shape of the shoe and hanger is wedged against the car side by its own weight. By a system of levers the door may be lifted and its weight thrown on to sheaves when it can be moved.

Moore ventilator. Fig. 4307. See *Ventilators*.

Morgan's automatic deck-sash pivot. Figs. 4385-8. A device for regulating the openings of deck-sashes, the essential feature of which is the use of a double circular undulating ratchet, one attached to the sash and the other to a fixed part of the car, the two ratchets being pressed together by springs so as to admit of easy motion of the sash by hand at the same time that it is held in any position when released.

Morris journal-box lids. Figs. 5167-9.

Mortise-lock. Figs. 2650, 2706. "A lock adapted to be inserted into a mortise in the edge of a door, so as only to expose the selvage or edge-plate."—*Knight*. See *Lock*.

Mould. See *Mold*.

Movable foot-rest (car-seats). 29, figs. 3924, and 23, figs. 3971-3. More properly, simply *foot-rest*, which see; in distinction from fixed *foot-rails* under the seats.

Muck-bar. "Bar-iron which has passed once through the rolls. It is usually cut into lengths, piled, and re-rolled."—*Knight*. Certain grades of iron axles are made directly from muck-bars and contain no scrap. See *Axle*.

Muffler (Eames vacuum brake). A device to render noiseless the emission of steam at the ejector when brakes are applied. It is simply a lot of beads or shot, through the interstices of which the steam forces its way.

Muley-axle. Figs. 5133, 5138 and 5146. An axle without collars. It is in much more favor than formerly and promises to be more generally adopted.

Mullion. A slender bar between panes of glass or panel work. See *Door-mullion*. 2, figs. 1783-93. *Window-blind mullion*. *Window-mullion*.

Multiple-circuit drum system. (Consolidated Car Heating Co.) Figs. 2961-8. A system of car heating by circulating hot water heated by steam from the locomotive by means of a *Drum*, 36, fig. 2363, placed longitudinally beneath the floor of the car, as shown. The piping in

the car is connected from this drum in a number of circuits so that there is a quick flow of water through the different circuits and all parts of the apparatus is run at practically the same temperature. Its time of circulation is about one-sixth of the time of circulation of a heater in which piping is arranged in series.

The advantages claimed for multiple circuits, are: 1, a low pressure of steam; 2, no limit, practically, to amount of heating surface, that can be supplied; 3, a more uniform heat is supplied to all parts of car; 4, short circuit of hot water circulation.

The circulating system, as shown, is also connected with a *Fire-proof heater*, which may be used when steam is not available, and in those States where the law permits a stove or heater.

Muntin. A corruption of the word *mullion*, chiefly used in England. See *End-stanchion* or *muntin*.

N

Nail. "A small pointed piece of metal, usually with a head, to be driven into a board or other piece of timber, and serving to fasten it to other timber."—*Webster*.

The common nails of commerce are divided into *cut* nails, and *clinch* nails, and *wire* nails, which see. They are distinguished in size by the number of pennies, as 10*d.*, 20*d.*, etc., nails. Other varieties, which see, are eyelet-nails, fig. 2855, head-lining nails and solid-leather nails. See also *Panel-pin* (English).

Name-panel. A panel, usually of elliptical form, on the outside of a passenger-car body below the windows, on which the name or number of the car is painted. They are no longer seen, having been replaced by a scroll or decorated ellipse, as in figs. 115, 123, 129, 135.

Name-plate. See *Door name-plate* and *Notice-plates*.

Narrow gage. The distance in the clear between the heads of the rails of a railroad when less than 4 ft. 8½ in. See *Gage*. What may be called the standard narrow-gage is 3 ft. In India and elsewhere the *meter gage*, 3 ft. 3¾ in., is the standard narrow gage. Less frequently 3 ft. 6 in. is used. The narrow gage at the present time is confined to short isolated lumber and coal roads and in mountainous districts.

Narrow-tread wheel. A wheel with the ordinary width of tread, which is usually about 4 in. See *Wheel*. *Car-wheel*.

National hollow brake-beam. Figs. 1546-60. A brake-beam consisting of a hollow tube 2-2½ ins. diameter, trussed by a rod passing through cast end pieces and over a *king-post*, through which the *brake-lever* passes.

Neck door-bolt. Figs. 2539, 2543. See *Door-bolt*.

Neck of axle. The sloping portion of a car-axle just inside of the hub of the wheel.

Needle-beam. "(Civil engineering.) A transverse floor-beam of a bridge, resting on the chord or girders, according to the construction of the bridge."—*Knight*. The term seems, however, to be more particularly used in bridge construction, as applying to the cross-pieces of queen-post trusses, supporting the floor and themselves supported by the truss. Hence (*car-building*), 22, figs. 229-66; 26, figs. 435-73. The *cross-frame tie-timber*, a transverse timber bolted to the under side of the longitudinal sills and floor timbers of a car-body between the bolsters, and to which the body king or queen-posts, or truss-blocks, are attached when truss-rods are used under a car-body.

The terms *cross-frame tie-timber*, *body-transom cross-bearer* and *needle-beam* are all more or less used, but *cross-frame tie-timber* is in most general use, and seems more precisely descriptive of its character than any other.

Needle-beam truss, or cross-frame truss. Fig 536, which see for names of parts.

Neponset red-rope car-roof. Figs. 2393-4. A car roofing, the lining of which is a tough manilla paper, made from so-called "manilla red-rope" and treated and prepared. See *Car-roof*.

- Nest-spring.** Figs. 5249-51, etc. A spiral spring with one or more coils of springs inside of it. See *Spiral spring*.
- Netting.** Figs. 3756-8. See *Basket-rack netting*.
- New York air-brake.** Figs. 1750-60. Air-brake apparatus made at the Eames Vacuum-Brake Company's works and sold by the New York Air-Brake Company. The devices sold are as identical with the Westinghouse equipment as the law will allow. Infringement cases have been brought and the matter is still in litigation. The apparatus was calculated to work in the same train with Westinghouse equipment, and to that end nearly all the parts are the same as those made by the Westinghouse Air-Brake Company. The parts which differ from the Westinghouse are shown in figs. 1750-4 and 1758-60. And of these few, fig. 1751, the *Quick-action triple-valve*, is a subject of litigation. The *Plain triple-valve*, *Duplex air-pump*, *Engineers' brake-valve* and *Drain-cup and Air-strainer*, with the names of parts, are shown in the illustrations referred to.
- Night-latch.** Figs. 2714-25. A spring door-lock which requires a key to be opened from the outside, but which can be opened from the inside without one. A *Spring door-lock*. See *Latch*.
- Nine-group spiral spring.** See *Spiral spring*.
- Nipple.** 1. In mechanics "a small rounded perforated protuberance, as the nipple of a gun."—*Knight*. It is often used, however, in a more general sense.
2. (Pipe fittings.) Figs. 2952-2954. A short wrought-iron pipe with a screw-thread cut on each end, used for connecting couplings, tees, etc., together or with some other object, as a tank or heater. See *Auxiliary-reservoir nipple*, *Brake-hose nipple*, *Solid nipple seat-arm*.
- No-chimney lamp-burners.** Figs. 3378-82. A style of burner so formed as to produce a sufficiently intense draft to avoid the production of smoke without the use of a chimney.
- Norton door-check.** Fig. 2818. See *Door-check*.
- Nosing.** 1. (Of a lock.) A *keeper*, which see.
2. (Of steps.) Figs. 3790-2. The part of a tread-board which projects beyond the *riser*, hence the metallic moldings used to protect that part of the tread-board. The *nosings* should be distinguished from the *step facings*, figs. 3788-9.
- Notice-plate.** Figs. 2773-93, and in place, 3, fig. 1788. Varieties are the *platform notice-plate*, *saloon notice-plate*, etc. See *Name-plate*.
- Nozzle.** See *Tank-nozzle*.
- Number.** Fig. 4228-32. See *Berth-number*.
- Number-panel.** See *Name-panel*. Now rarely used on modern cars. The number is simply painted on between horizontal bars.
- Nut** (standard sizes for). Fig. 5498. "A small block of metal or wood containing a concave or female screw."—*Webster*. Nuts take their name from the bolts, rods or other parts to which they are attached. They are usually either square or hexagonal. A *spanner nut*, which see, is one with eight or more sides. They are usually more truly *couplings* than nuts, properly so called, which screw on to a bolt or rod.
-
- Oblique closet-hopper.** Fig. 3867. See *closet-hopper*.
- Observation-end of a car.** Figs. 121-2, etc. A car, one end of which is fitted with an extended platform, and large windows, from both of which passengers may get a good view of the country and especially of the track and structures. They are coupled at the end of the train and the observation-end is a feature of many officers-cars.
- Odometer velocipede-car.** Figs. 5605-6. A car with a sprocket-wheel and chain connecting one of the wheels with a series of dials which indicate the number of revolutions the wheel has made and the distance traveled.
- Officers'-car.** Figs. 118, 119, 120, 494-6. A car for the private use of the higher officers, directors, etc., of railroads in traveling over their lines. They are usually provided with kitchens. They are sometimes very elaborate and costly—sometimes merely business cars. A *pay-car*, figs. 487-93, is a special variety, found on nearly all roads from 300 to 600 miles long.
- Offset butt-hinge.** Fig. 2607.
- Oil axle-box** (English). A *journal-box* in which oil is used instead of *grease* as a lubricant. The oil is fed to the under side of the journal by means of a worsted pad held lightly against the journal by spiral steel springs. See *Axle-box cover*, and *Greass axle-box*.
- Oil-box.** A *journal-box*, which see.
- Oil-car.** A car made especially for the transportation of mineral oil. Some oil-cars are built for carrying barrels of refined oil. Crude oil and refined oil are usually carried in *tank-cars*, which see, figs. 48-9, and 373-6; or in combination box and tank cars.
- Oil-cellar.** A cavity in the lower part of some exceptional forms of journal-boxes for collecting the oil and dirt which runs off the axle at the dust-guard. The oil-cellar is *below* the space occupied by the axle-packing.
- Oil-cup.** (Air-cylinder of Westinghouse pump.) A small metal pump attached to an air-pump to hold oil for lubricating an air-piston.
- Oil-lamp.** A cheap metal lamp for burning lard or whale oil. A lamp for mineral oil is an oil-lamp, but generally not so termed.
- Oil-screws.** Figs. 3385-6. Fittings for *oil-lamps*, which see.
- Oil-tube** (of student-lamp). **F**, figs. 3398-9. The vertical tube in which the wick lies. The horizontal-bar is the *feed-tube*.
- O. K. (air) brake slack-adjuster.** Fig. 1770. A device consisting of a rack and lever-pawl, by which the length of the *cylinder piston-rod* is adjusted so as to take up the slack of the brake-gear. See *brake-slack adjusters*.
- O. K. Gardner sash-balance.** Fig. 4512. A sash-balance which is placed in the roof near the eaves of the lower deck, as shown in fig. 447, **102a**, and in fig. 491.
- Opalescent-Wart dome.** (Pintsch gas lighting.) **101**. Fig. 3201. May be used on any center-lamp, as may also opal-dome, **104**, fig. 3208.
- Opal-globe.** (Pintsch gas lighting.) **102**. Fig. 3216. It is for use on bracket-lamps of all descriptions.
- One-horse street-car.** Also called *bob-tail street-car*. See *street-car*.
- Open-door stop.** **71**, figs. 229-66. A block of iron or wood fastened to the side of a freight-car to prevent a sliding-door from sliding too far when opened.
- Opener.** See *Deck-sash opener*, *Ventilator-opener*.
- Open excursion car.** Fig. 151. An open car with curtained sides for short suburban runs to summer resorts.
- Open link for Miller hook.** See *Janney-Miller coupler*.
- Open plate-wheel** (street-cars). Figs. 5362-3. A light cast-iron *single plate* wheel, with openings cast in the plate between the ribs. See *Wheel*, *Car-wheel*.
- Open return-bend** (pipe fittings). Fig. 2946. A short cast or malleable iron U-shaped tube for uniting two parallel pipes. It differs from a *close return-bend*, fig. 2945, in having the arms separated from each other.
- Open wagon** (English). Figs. 348-51. American equivalent, *four-wheeled gondola-car*. A vehicle with sides and ends from 6 in. to 5 ft. high, and having no roof suitable for the conveyance of freight. A *tarpaulin*, which see, is used to protect the freight from the weather. See also *Wagon*.
- Ore-car.** Figs. 20, 27, 325-7, and 332-5. A car made especially for carrying iron or other ores. Ordinary gondola-cars, which are sometimes lined with sheet iron, and drop-bottom and tip-cars are also used for this purpose.
- Ormolu.** Literally, *ground gold*, a style of bronzing metallic surfaces.

Ormolu-hook (postal cars). Fig. 3814. A kind of pouch-hook.

Ornamental-carlines. 4, figs. 2452-3a. Also in figs. 103, 107, 111-2, 116-7, 122, 126, 130, 133. A recent innovation of breaking up the interior of a car into section by very heavy, prominent and highly decorated compound carlines.

Ottoman. Fig. 3706. A carpet-covered movable cushion serving as a foot-rest.

Outer-center-stem-guides. Fig. 1407-9. 22, figs. 2296-2300. See *Buffer stem-guides*.

Outer-cone (graduated bolster-spring). See *Spring. Spiral spring*.

Outer double floor, or floor underlining (English). 143, figs. 501-4. American equivalent, *deafening-ceiling*. In a carriage, planking attached to the under side of the framing and floor of the body. The space between it and the true floor is generally filled with sawdust.

Outer-hung brake. Figs. 1528-9, 4740-6. Brake-shoes and beams attached to the outside of the wheels of a truck or four-wheeled car. They are usually hung from the car-body, but sometimes the truck-frame is extended and brakes are hung from it. When hung between the wheels it is an *inner-hung* brake. Outer-hung brakes were formerly the favorites. The more common practice now is inner-hung brakes.

Outer intermediate-sill. Figs. 229-66. A term applied to the two intermediate-sills next to the side-sills, to distinguish them from the two intermediate-sills adjacent to the center-sills, which are the *inner intermediate-sills*.

Outer side-stem guides. Figs. 1404-6. 23, figs. 2296-2300. See *Buffer stem-guides*.

Outside body-truss-rod. When two or more truss-rods are used under each side of a car-body, those farthest from the center are called *outside body-truss-rods*, in distinction from the *inside truss-rods*.

Outside-casing. (Heaters.) Figs. 2908-2924. An outside shell made of Russia-iron or *sheet steel* and bent and riveted into the form of a cylinder or a frustum of a cone.

Outside corner-plate (English). 77, figs. 348-51. A plate placed outside of the body, securing the side and ends together; made, as shown, a continuous plate, or in several knees, each $2\frac{1}{2}$ in. deep.

Outside cornice (English). See *Side gutter*.

Outside cylinder (of student lamp). B, fig. 3399. The sheet surrounding the reservoir.

Outside end-piece (of wooden truck-frame). Figs. 4833-5. The cross-piece next to the end of the car, in distinction from the *inside end-piece*.

Outside end-sill. Figs. 2, 232-43. A type of box-car framing in which the end-sill projects outside the sheathing, forming a narrow platform at the ends of the car. It is not the general practice, but is peculiar to the Pennsylvania Railroad and a few other lines.

Outside-panel. 67, figs. 435-73; 43, figs. 5654-67. A panel in the outside of a passenger or street-car under the windows. Those between the windows are called *outside window-panels*. Above the windows comes the *freize* or *letter-board*. Street cars have *lower*, 44, outside-panels, below the outside panels proper. In standard car construction outside paneling between and below the windows has been superseded by sheathing.

Outside-sills. The *side-sills*. See *Sills*.

Outside transoms (six-wheeled trucks). 22, figs. 4957-66. The two transoms farthest from the center of the truck, in distinction from the *middle transoms*.

Outside wheel-bars (iron six-wheel truck). An iron substitute for wooden wheel-pieces.

Outside wheel-piece plate. 11, figs. 4842-4966. An iron plate fastened to the outside of a wheel-piece to strengthen it. There are two when any are used, *outside* and *inside*. They are usual on six-wheel trucks and frequently met on late construction of four-wheeled trucks.

Outside window-panel. 68, figs. 438. See *Outside panel*.

Outside window-sill. 77, figs. 435-73, 539-41. A horizontal piece of wood or iron under a window on the outside of a car and on which the sash rests.

Outside window-stop. 84, figs. 435-73. A wooden strip attached to a window-post on the outside of a sash to hold the latter in its place. Often called a *bead*, which see.

Oval coupling-pin. Figs. 2284-7. A *flat coupling-pin*. See *Coupling-pin*.

Overhang (of a roof). The projection beyond the sides.

Overhang (of a car-body). That part of a car-body between the body bolster and end, and which is not supported by the *body truss-rod*.

Overhang brace-rod (passenger-car framing). 167, and 220, figs. 437, 456, 512. A *truss-rod* extending over the *side-sills* and between the sheathing and wainscoting. Its office is to sustain and stiffen that part of the underframe which overhangs at the ends and outside the bolsters. It may pass from end to end of the side-sills, as in fig. 437, or equal distances on both sides of the bolster, as in fig. 456. Usually it passes from the end of the side-sill diagonally up to the belt rail and over a *queen-post* called the *overhang brace-rod strut*, and then along close under the belt rail to the other end of the car and down to the end of the side-sill. Frequently they extend diagonally down on both sides of the *overhang brace-rod strut* (which then becomes a *king-post*), and diagonally through the sill. The overhang brace-rod strut stands upon the sill directly over the body bolster. It is sometimes called an *inverted truss rod*, a *continuous body brace-rod*, *body chain-rod*, and a *hog chain-rod*.

Overhang brace rod-strut. 221, figs. 437, 456, 512. A vertical cast or wrought-iron strut seated upon the side-sill directly over the body bolster and acting as a *king-post* or *queen-post* for the overhang brace-rod. (See *Overhang brace-rod*.)

Overhang truss. Shown in fig. 512. An inverted truss, forged or cast, the office of which is to support and stiffen the overhang ends of a passenger-car underframe. It is used only in very long and heavy cars and is intended as an auxiliary to the overhang truss-rod. Its use is confined to palace and sleeping cars.

Overhead equalizer spring (Pullman vestibule). 23, figs. 2437-45. A *Face-plate buffer-spring* is a more appropriate term, as it corresponds to the *side-stem buffer-spring* of a platform equipment. It affords the spring pressure on the *face-plate stem*, which is attached near the top of the *face-plate* and keeps it forced out.

Over-hung door. A sliding-door which is hung from or supported on a rail above the door. If the door is supported by a rail below it is called an *under-hung door*. Over-hung doors are almost universal for freight-cars. See *Door-hanger. Car-door hanger*.

P

Package-rack (drawing-room cars). Figs. 3753-70. A small rack analogous to the basket-racks of ordinary passenger-cars and the only substitute therefor used in drawing-room cars.

Packing. *Journal-packing*, which see.

Packing-blocks. 186, figs. 229-66. Rectangular blocks gained into the center-sills and *draft-timbers*, and serving the purpose of connecting them firmly together longitudinally. The term is borrowed from bridge work, in which the form of packing-block shown is very common. They are called *key-blocks*.

Packing-expander (Westinghouse brake). 12, fig. 1689. A spring wire ring for spreading out the leather-packing of the piston so as to make it fit air-tight. See *Piston packing-expander*.

Packing-gland. See *Piston-rod*.

Packing-leather. 1. (Of journal-boxes.) Figs. 5155, 5159. A *dust-guard* is sometimes called packing-leather.

2. (Westinghouse brake.) A ring of leather used in connection with *brake cylinder pistons* to make an air-tight joint. When so used it is always accompanied with a *packing-leather expander*. A packing-leather for a piston-rod is called a *cup-leather*, and is compressed by a *piston-spring*. See *Piston packing-leather*. *Piston-rod packing-leather*.

Packing-nut. (Westinghouse brake.) See *Piston-rod packing-nut*.

Packing-nut wrench. (Westinghouse brake.) See *Wrench*.

Packing-ring. 1. (Westinghouse brake.) 12, 13, figs. 1689, etc. See *Piston packing-ring*.

2. (Hose-coupling.) An india-rubber ring in a coupling-case, which makes a tight joint between the two parts of the coupling.

Packing-spring (for piston-rod of Westinghouse driving-wheel brake-cylinder). A spiral spring clutching the *piston-rod cup-leather*, and pressing it air-tight against the piston.

Padlock. Figs. 2760-72. A loose lock having a semi-circular *shackle* jointed at one end so that it can be opened, the other end of the link being locked when desired by the entrance of the *sliding-bolt* into it. Such locks are used to secure a *hasp* or the like on a *staple* or similar device by passing the link through the staple. A *spring padlock* is one which snaps shut and locks by pressure only. A *dead padlock* has no springs.

Padlock-hasp (car-door fastener). See above.

Paige steel-tired wheel. Figs. 5308-11. A type of steel-tired wheel, the hub and skeleton (*wheel-center*) being in one piece, and the tire secured thereto by *front* and *back face-plates*, *hub-bolts* and *tire-bolts*. It has no retaining ring, although the company does make a wheel whose tire is fastened by retaining rings. Figs. 5312-13.

Painting (of passenger-cars) consists usually of the *priming*, *rough-stuff* or *scraping-filling coats*, *color coats* and *varnishing*, all of which see. The care and expense devoted to the process and the order and number of the various coats are often varied, but the following is among the most approved processes, and the order of the coats and time required for each coat to dry are about as follows :

	Hours.
Priming (which see) with drier.....	24
Scraping filling coat (2 coats).....	48
Color coats (which see) (3 coats).....	72
Color and varnish.....	24
Striping.....	24
Finishing varnish (which see) (2 coats).....	48
Total.....10 days or hours.....	210

A process known as "Murphy's A, B, C system is also used. A, being a liquid used for priming or first coat on new wood; B, a liquid heavier in body than A, which is used for the second and third coat. C is a still heavier liquid, applied over B, and when thoroughly dry and hard is rubbed down to a smooth surface with water and block pumice stone, leaving the surface ready for the *Color coat*.

Other systems are the "lead and oil" and the "M, J, S." The former being a very old method and the latter a very simple method, consisting simply of a priming or filling coat, followed by a surface coat that is rubbed down with pumice stone or sand paper, preparatory to the *Color coat*.

Pair of trucks. A pair of trucks means two truck-frames, each with two or more pairs of wheels, etc., complete for an entire car, and does not mean *one* truck-frame with wheels and axles for one end of a car only.

Pair of wheels. This term is used to designate two car-wheels fitted on one axle, *including* the axle.

Palace-car. An extravagant term used to designate sleeping, drawing-room, parlor and chair-cars (which see), which are fitted up with more than the ordinary amount of ornament and elaborate finish and furniture.

Palace stock-car. An extravagant general term applied to cars designed for carrying stock with less injury and greater comfort than the common stock-car. Cars built after the plans of so-called *palace stock-cars* are in general use, and are shown in figs. 39-47 and 359-72. They are provided with apparatus for feeding and watering, and those for very valuable stock have separate stalls partitioned off.

Pan. 1. (Refrigerator cars.) I, fig. 284. The *ice-pan*.

2. (Howard's parlor-car water-closet.) Figs. 3838-9. The basin forming the bottom of the bowl, so constructed that it is only brought into position and filled with water on raising the lid.

Pancoast-patent ventilators. Figs. 4319-24. See *Ventilators*.

Panel decorations. Figs. 3660-3.

Panel. 1. A board inserted in the space left between the *stiles* and *rails* of a frame or between moldings. Sometimes metal plates are used for this purpose. *Door-panels*, figs. 1783-93, in passenger-cars are usually only the *middle* and *lower* or *twin door-panels*. The upper door-panel is usually of glass. *Window-panels* come between the windows and are distinguished as *outside* and *inside*. *Wainscot-panels* come below the windows, between the upper and lower wainscot-rails. Other interior panels are *deck-side panels* and *end-panels*, the latter sometimes called *ventilator-panel*, and the *end-roof panel* over the door. The exterior panels are the *end-panel* below the windows and the *end-window panel* alongside of the window. A *name-panel* is now quite obsolete. In street cars additional panels to those above named are an *upper-end panel*, which also sometimes occurs in passenger-cars, a *lower outside-panel* or concave below the outside panels proper; *inside frieze-panels*, *end-seat panels* and *door-case seat-panels* and *top-panels*.

2. (Of a truss.) The space between two vertical posts or braces and the two chords of a truss.

3. (English.) In a carriage, the outside sheathing of the body. Teak and mahogany are generally used for this purpose in England, and sheet-iron on the Continent of Europe. See *Bottom door-panel*. *End-panel*. *Quarter-light panel*

Panel ceiling. Properly any form of ceiling divided up into panels, but in popular custom used as synonymous with *wood ceiling*, which is always divided into panels, in distinction from a *head-lining* of canvas, lignomur, etc.

Panel-furring. 59, figs. 435-73 and 59, 59b-e, figs. 536-8. Horizontal bars or strips of wood between the posts of a passenger-car, and to which the outside panels are nailed. When a strip is made continuous and extends from one end of the car to the other, and is notched into the posts, it is called a *panel-rail*. *Window-panel furring* is included in the general term, and is that coming between the window-posts.

Panel-lamp. An *alcove-lamp*, which see.

Panel-pin (English). A small headless nail of copper, brass or iron, used to secure the outside sheathing (*panel*) of a passenger car to the framing of the body.

Panel-rail. 66, figs. 531-8. See *Panel-furring* or *Sheathing-furring*.

Panel-strip. 69, figs. 435-73. A narrow piece of wood or metal with which the joint between two panels, or a panel and a post, on the outside of a car, is covered.

Panel-washer. 53, fig. 5654. The washers of the transverse floor-timber tie-rod of a street-car.

Pantasote. A substitute for leather and in extensive use for upholstering and decorating cars and steam-ships. The material was first made by R. P. Bradley, a chemist, and the ingredients are a secret. That it contains rubber or any animal substance is denied. It is made by sheeting two or more pieces of cloth or canvas together, with the warp running in different directions to give

- strength. The sheet making the leather side is passed between heavy rollers many times, and each time it receives a very thin coat of pantasote material, and this is kept up until the cloth or canvas is literally saturated and coated. The color is added to the pantasote material and is incorporated into the fabric. It is very like leather and is not readily distinguished from it.
- Paper-case casting.** Fig. 3832. A cast-side or bracket-frame for a paper-case in *Postal-car*.
- Paper-holders.** Figs. 3850-1 (which take rolls of closet paper.) See *Paper-hook*.
- Paper-hook** (for saloons). Figs. 3852-3. A hook for carrying closet paper in sheets. A carrier for perforated continuous-roll paper is in larger and increasing use. Figs. 3850-1.
- Paper seal-holder.** Fig. 3897. A style of seal-holder (of which several patterns exist), in which a sheet of paper or printed label is used to protect the lock against unauthorized opening. The paper is usually protected by glass.
- Paper wheel.** More properly, *Allen paper-wheel*. Figs. 5255-6. A car-wheel with a steel tire and a center formed of compressed paper held between two plate-iron face-plates. It is in general use. The compressed paper can be turned and polished like wood.
- Parallel brake-hanger.** 122, figs. 4580-4966. See *Brake-beam adjusting-hanger*.
- Parallel brake-hanger carrier.** See *Brake-beam adjusting-hanger carrier*.
- Parallel brake-hanger eye.** See *Brake-beam adjusting-hanger clip or eye*.
- Parallel-rod** (walk-over seat). 36, figs. 3117-18. A rod which carries two gear-wheels, one at each end, and which insures the *Seat-back arms* remaining parallel. If one *seat-back arm* be moved the arm at the other must move the same amount. The parallel-rod also carries two *seat-tilting levers* which tilt the *seat-rocker* or *tilting-casting*, thus tilting the cushion.
- Parcel-net** (English). 194, figs. 501-4. American equivalent, *basket-rack*. In a carriage, a netting placed transversely above the seats for the purpose of carrying light baggage, parcels, etc. The front edge is attached to a wooden bar called the *parcel-net rod*, which is supported by a *bracket*.
- Parcel-net bracket** (English). 193, figs. 501-4. See above.
- Parcel-net rod** (English). 192, figs. 501-4. See above.
- Parcel-rack.** See *Basket-rack*.
- Parcel-van** (English). American equivalent, *express-car*. A closed vehicle adapted to run on passenger trains and to carry parcels and packages, rather than passengers' baggage. Such business in England is done by the railway companies themselves, and not by separate corporations.
- Parliament-hinge.** Fig. 2590. See *Hinge*.
- Parlor-car.** Figs. 111-17, 162, 178, 190, 512-30. See *Drawing-room car*. The names *parlor-car*, *drawing-room car* and *chair-car* are all used somewhat indiscriminately, but *chair-car* ordinarily refers to a parlor-car with adjustable or reclining chairs, for riding in which no extra fare is charged. Parlor and drawing-room cars are usually run by separate companies. See *Bay-window parlor-car*, figs. 547-9.
- Parlor-car chairs.** Figs. 3926-7, 3977-9, 3988-92. The most common type of chair for parlor-cars is a simple arm-chair revolving on a *pivot* which enters a fixed *pedestal*. The *Hartley* and *Hitchcock* chairs, figs. 3996-9, which see, have for some reason been mainly confined to a class of parlor-cars run without extra charge as ordinary first-class passenger coaches. See above.
- Parlor-car water-closet** (Howard's, which see). Figs. 3838-9.
- Parting-bead, or parting-strip.** A long thin piece of wood which acts as a distance-piece between two objects, as a window and a window-blind. See *Sash parting-strip*.
- Parting-rail** (of door-frame, which see). 7, fig. 1788. A vertical rail between the bottom and middle or middle and top rails of a door or partition, dividing a panel into *twin-panels*.
- Partition** (English). 130, figs. 501-4, etc. A vertical division dividing the interior of the body into separate compartments, generally extending completely across the vehicle from side to side, and from floor to roof, but occasionally made to extend only some four or five feet from the floor, leaving a clear space between the top and the roof. This practice is, however, going out of favor.
- Partition-stop** (for door-holder). Figs. 2803-6. So called in distinction from a *floor-stop*, with which a *door-holder* engages.
- Partition-wall** (Mann boudoir-cars). 16, fig. 2418. The wall between the separate boudoirs.
- Passenger car or coach.** Figs. 89-100, 419-467, 539-41, 531-567. Literally, a car used for carrying passengers, but in popular practice restricted to ordinary vehicles for day travel in distinction from *sleeping-cars*, and sometimes in distinction from the more luxurious *parlor-cars*, *drawing-room cars* or *chair-cars* (which see), as well. Passenger-cars are also very commonly termed *day-coaches* or "first-class" coaches. *Second-class* coaches are very rarely run, although there are large numbers of *emigrant-cars*. A *smoking-car* is usually attached to all trains, and holders of second-class tickets or tickets bought at reduced rates are often required to ride in the *smoking-car*. See *Car. Coach*.
- Passenger-car truck.** Figs. 4806-4966. A truck for carrying a passenger-car body. Such trucks are usually wooden frame and have two sets of springs, *bolster springs* under the truck-bolster between the two truck-frames and *equalizer springs* attached to the outside truck-frames. They always have swing-bolsters. The wooden truck-frames are usually reinforced with iron plates, especially for six-wheel trucks, which latter are almost always used for sleeping and parlor cars. Other passenger-cars usually have four-wheel trucks. See *Truck. Car-truck*.
- Passenger couplers.** Figs. 2244-2354, showing the *Drexel*, *Gould*, *Janney*, *Miller*, *Standard*, *Thurmond-McKeen*, *Trojan* and *Vandorsten*. The coupler heads are all forms of the M. C. B. Automatic Coupler, excepting the Miller. The differences being devices to unlock the knuckle and the manner of attaching the couplers to cars. A marked difference is in the length of the shank, which varies from 67 inches in the Drexel to 32½ inches in the Janney. *Center draft draw-bars* (the *Barnes* and the *Manhattan*) are shown in figs. 2282-9. See *Automatic car-coupler*.
- Pasting-lace** (English). Figs. 501-4. An ornamental woolen fabric, made in bands about ¼-inch wide, and used to finish and cover the seams and joints in upholstery against the woodwork of a carriage round the *quarter-lights* and *front seat-rail*, and to form borders to the *broad lace* above the *back squabs*. It is fastened by tacks driven in the tape edge, the main part being then turned over to hide the tacks, and pasted in position. See also *Seaming lace*.
- Patent overflow** (for wash-basins). Fig. 3869. A tube formed in the basin itself for connecting the upper waste holes with the regular waste pipe from the bottom of the basin, so that but one pipe connection need to be made.
- Patent waste.** A preparation of cotton-seed hulls used for journal packing. See *Elastic fiber*.
- Pawl.** 1. (For brake ratchet-wheel.) 103, figs. 229-66. "A pivoted bar adapted to fall into the notches or teeth of a wheel as it rotates in one direction, and to restrain it from back motion. Used in windlasses, capstans and similar machinery."—*Knight*.
- In most of the English dictionaries *ratchet* is given as another name for pawl, but this is believed to be incorrect, according to present practice. See *Ratchet-wheel*.
2. (For ratchet-wheel of winding-shaft.) See above, and 67, figs. 305-315.

Pear-shaped lamp-globe. Fig. 3433. See *Lamp-globe*.

Peckham car-trucks. (Street-car.) Figs. 5670. Other types not shown are built.

Pedal alarm-gong. (Street-cars.) 199, fig. 5655. A large bell sounded by striking a stem, connected by a lever with the clapper, to warn teams and persons of the car's approach.

Pedestal. 1. 5, figs. 4806-496, 4967-9. M. C. B. standard, figs. 5480-3. A casting of somewhat the form of an inverted letter η bolted to the *wheel-piece* of a truck frame, to hold the journal-box in its place, while permitting a vertical movement. The two projections of a pedestal are called *pedestal-horns*, and the space between them a *jaw*, which is closed at the bottom by a *jaw-bit*, which see. In Great Britain, pedestals are called *axle-guards* on cars and *horn-plates* on locomotives, and are there made of wrought iron. The M. C. B. pedestal, shown in Figs. 5480-3, was recommended in 1874, and again approved as standard in 1881, and approved by the Master Mechanics' Association, in the same year. Again adopted as standard in 1893. Weight, 141 pounds.

2. A casting serving as a fulcrum. See *Equalizing-bar pedestal* (caboose-cars, etc.). *Leader trunnion pedestal* (pile-driver cars).

3. (Hartley and other revolving chairs.) 12, figs. 3998-9, 4109. The stand by which the chair is supported consists of three portions, *base*, *column* and *seat-frame*.

Pedestal-box. A *journal-box*, which see. Figs. 4758-60, 5133-66.

Pedestal-brace. 8, figs. 4806-4966. A diagonal bar or rod staying the lower end of a pedestal longitudinally. It is often combined into one piece with a *pedestal tie-bar* to form a *pedestal brace-tie-bar*.

Pedestal brace tie-bar. 8', figs. 4806-4966. A *pedestal-brace* and a *pedestal tie-bar* combined in one piece. See above.

Pedestal-horns. See *Pedestal*.

Pedestal-jaw. It is closed at the bottom by a *jaw-bit*. See *Pedestal*.

Pedestal-spring. A *journal-spring*, which see.

Pedestal stay-rod. 7, figs. 4806-4966. A transverse rod connecting the pedestal tie-bars on each side of a truck so as to prevent them from spreading apart.

Pedestal tie-bar. 3, figs. 4806-4966. An iron bar or rod bolted to the bottom of two or more pedestals on the same side of a truck or car, thus holding or tying them together. The pedestal tie-bar is to get a low truck. Sometimes it is given a half-turn for additional stiffness. It is also sometimes combined with a *pedestal-brace* to form a *pedestal brace-tie-bar*, which see.

Pedestal-timber. 1. (Four-wheel cabooses, etc.) 169, figs. 385-88. A longitudinal timber sometimes used on four-wheeled cars, which is placed under the floor or alongside the sill and to which the pedestals are bolted.

2. 10, figs. 4806-4966. A term sometimes used to designate the *wheel-piece* of trucks, which see.

"**Penfold**" **card-rack** (freight-cars). A rack for carrying *destination cards*, which see.

Pennsylvania hand-car. Figs. 5595-7, gives details and dimensions.

Perch. Another name for the draw-timbers of a tip-car, on which the floor is not directly built. The name comes from the *perch* of wagons connecting the front and hind running-gear. See *Car perch*.

Perfection car-seal or shackle. Figs. 3888-a.

Perforated-rubber floor-mat. Fig. 2857. Another style is the *corrugated-rubber floor-mat*.

Perforated smoke-pipe casing. Fig. 3085. An outside pipe which incloses the smoke-pipe of a stove, perforated with holes through which the air circulates, and thus comes in contact with the pipe. The casing also protects the wood-work of the car from radiated heat.

Perforated veneer. Figs. 3993-4. A form of seat-covering

which consists of three and sometimes four layers of wood veneering, glued together and perforated with holes for ornament and ventilation. It is in very general use for the seats of second-class and smoking-cars.

Philadelphia water-closet. Fig. 3870.

Phosphor-bronze. "A term applied to an alloy of bronze or brass (which see), or to a triple alloy of copper, tin and zinc, which has been given special purity and excellence by skilful fluxing with phosphorus. It is supposed that the presence of phosphorus gives the tin a crystalline character which enables it to alloy more completely and strongly with the copper. Whether for this reason or not, the phosphor-bronzes, when skillfully made, are greatly superior to unphosphorated alloys."—*Thurston*.

Piece.

See *Center-piece*.

Distance-piece.

End-piece.

Wheel-piece.

Pilaster. 1. (Architecture.) "A square pier, like a flat column built against a wall, and having cap and base."—*Knight*.

2. (Car construction.) Any stick or timber fastened against another piece to serve merely as the supporting block or a cross-piece, as *pilaster* (pile-driver car). 5, fig. 403.

Pilaster-pocket (pile-driver car). 16, fig. 403.

Pile-driver car. Figs. 221, 397-404. A class of cars, one of which at least is kept upon most large railways, the details of which vary, but which are similar to one of the two types shown. The essential features of a pile-driver car are the *swinging-platform*, or *upper-platform*, 27, figs. 401-4, carrying the *cabin* and frame-work upon which the *leaders* and *hoisting-engine* and the accompanying gear are carried. The swinging-platform is to enable piles to be driven at a considerable distance from the rails on either side. To enable the cabin to beswung through a wider arc, adjustable *wings*, 20, are fixed to the side of the car, which are removed when not required for use by the *crane*, 34. The leaders are usually long enough to take a 35 to 40 ft. pile and swing upon *leader-trunnions*, 15, so that the leaders may be dropped back upon the roof of the cabin for transportation over the road. The *hammers* weigh from 4,000 to 4,500 lbs.

Pile-hoisting sheave (pile-driver car). 11, fig. 401-4. A wheel placed at the side of the main sheave for use in hoisting piles. It projects a little further forward than the other, so as to swing the pile more easily clear of the leaders.

Pillar. 1. "A kind of irregular column.

2. "A supporter; that which sustains or upholds; that on which some superstructure rests."—*Webster*. See *Transom-pillar*.

Pillar crane. Fig. 392-3. A style of crane (used on wrecking-cars), having the mast supported from below, either by a *mast-pocket* or a *base-plate*. See *Derrick*.

Pillar-supported center-lamp. Figs. 3235, 3237-8, 3252-7.

Pillow-box (Mann boudoir-cars). G, fig. 2418. (Sleeping-cars.) 19, fig. 2412.

Pin. "A peg or bolt of wood or metal having many uses."—*Knight*. In railroad service the word, when used alone, commonly means a *coupling-pin*.

See also *Brake-block pin*.

Center-pin.

Door-pin.

Head-block pin.

Hanger-pin.

Journal-box-cover hinge-pin.

Lateral-motion spring-pin.

Platform-lever pin.

Push-bar pin.

Pinion. 1. The smaller cog-wheel of two wheels in gear. See *Shifting-pinion*.

2. (Hand-car.) 4, figs. 5592-5600. A small gear-wheel attached to the axle of the car, into which the larger wheel on the *crank-shaft* gears.

3. Pinion is sometimes incorrectly used in the sense of a small *pivot-pin* or journal.

Pintle. "A pivot-pin, such as that of a hinge. The king-bolt of a wagon."—*Knight*. See *Brake-lever pintle* (hand-car).

Pintsch gas-burner. 222, fig. 3211. Used on all Pintsch lamps other than the bracket lamps. It consists of a small lava tip of the "fish-tail" type, held in a special brass pillar. Its consumption is about $\frac{3}{4}$ cubic ft. per hour. A larger burner of the same type, 223, is usually employed on bracket lamps. Its consumption is about 1 cubic foot per hour.

Pintsch gas-lamp. Figs. 3235-43, and 3250-1. A lamp for burning gas, the essential features of which are the closed globe at the bottom, the white porcelain reflector, 113, above the flames near the top of the globe, and the peculiar method of supplying air.

Various forms of *center-lamps* are made, all on the regenerative principle, the inlet air being highly heated before reaching the flames, thereby producing extreme whiteness and steadiness of light.

Some of these lamps are supported by four ornamental arms, figs. 3236, etc., one of which forms the *gas-way*; others are supported by central columns of graceful design, figs. 3235-3237. In all, the interior of the lamp is so constructed that a portion of the light is reflected outward and upward toward the roof of the car, illuminating the same.

In all *standard center-lamps*, figs. 3238, 3240, 3242, air is admitted to the lamp immediately above the upper dome, 101, or 104, fig. 3242. Passing thence through the orifices in chimney, 313, it comes in contact with the sheet-iron flues, 312, and in its downward passage becomes highly heated. It then issues into the space within the dome, 101, between the *dome* and the *mica-chimney*, 109, fig. 3199, and continuing its course is by the *diaphragm*, 315, deflected and constrained to pass close to the *mica-chimney*, where it is still further heated. It now passes outward between *diaphragm*, 315, and the ring reflector, 110, fig. 3207, and through the orifices near the outer rim of this reflector into the bowl and to the flames. In its tortuous course the effect of drafts against the lamp is entirely nullified.

The products of combustion escape directly through the annular space between *mica-chimney*, 109, and the *cup-reflector*, 111, fig. 3206. Thence by flues, 312, out through the crown at the top of the lamp, in the case of the four arm lamps, and through the flues, 333, and of the center suspension lamps, fig. 3233, through 336.

In *vestibule-lamps*, two or four flame, figs. 3239-41, air is admitted to the annular space between the parts of ventilating chimney, 324, through the shielded opening above the roof, immediately below the ventilator. Becoming heated in its downward passage, it passes through the diaphragm, 323, and through the orifices in the body, 320, to the flames, as shown by the arrows. The products of combustion escape through the flues, 321, and the chimney, 324, to the outside air. Any excess of air, over and above what is required for proper combustion of the gas, will also be carried off by the ventilating chimney, which the air reaches from the space above the body by means of the passage around the outside of the chimney, 321.

Bracket-lights, *wall lamps* for express cars, and *vestibule-lamps*, figs. 3228, 3239, 3241, 3246 and 3247, are supplied in various designs and forms.

The burner is of the "fish-tail" type, and from one to six are used in each lamp or light, four being the number generally adopted. See *Pintsch burners*. Consumption of gas is at the rate of about $\frac{3}{4}$ cubic feet per hour for each burner enclosed in a lamp, or 1 cubic foot per hour for single open burners.

Pintsch gas-lamps. (Method of securing and connecting.)

Four-arm lamps. Figs. 3236, 3240. The arms are secured by means of *nipples*, 26, passing through the roof; a water-tight joint around the nipples on the roof being made by bedding the cap on the nipple, with a *nut*, 27, and the *iron-washer*, 28, are then put

on and forced down until the excess putty is forced out and the arm drawn firmly up to its place. The *gas-arm-nipple* is then supplied with the *reducing-ell*, 28, the three *blank-arms* with *caps*, 29. The *ell*, 28, is then connected by the $\frac{1}{2}$ -in. pipe to the *flange-tee*, 16c, on the roof line. The roof around the *smoke-bell* is protected with a tin thimble, large enough to give a $\frac{1}{2}$ -in. air-space around the smoke-bell flue. The upper end of this thimble is made of proper size to receive the *ventilator*, 204.

Center suspension-lamps (fig. 3238) are supported by means of the *gas-way pipe*, 329, which passes through a *roof-casting*, 337, being secured above the roof-casting by a locknut, 56, and the reducing elbow, 28A. The *roof-casting* is set in putty and screwed to the roof, the *ventilator*, 204, fitting down closely over the upper part of the casting.

Pintsch pillar. 230, fig. 3213. Used on bracket lamps below the burner, 222, fig. 3211. Where no globe holder is used, mill check, 231, fig. 3223, is placed immediately below the pillar, 230.

Pintsch system of gas-lighting. Figs. 3160-3251. A system of car-lighting which burns gas taken from a storage tank, where it is carried under a pressure of 150 lbs., or less, per square inch. The system is well and favorably known. It is applied to over 6,500 cars in this country, 700 of which are street-cars. The gas is an oil-gas, made from crude petroleum or similar oils, and is able to withstand a high degree of compression without undue loss of luminosity. The pressure of 150 lbs. of the receiver-tank is automatically reduced by the Pintsch regulator (fig. 3168) to a uniform pressure at the burners of about $\frac{1}{2}$ oz., regardless of the pressure in the gas-receiver. Works for the supply of the gas are now established in all the large cities. The supply carried on a car varies with the service, but is, in general, calculated to supply the car for from two to four nights.

The arrangement of the apparatus is shown in fig. 3160. The *receiver* or *gas-holder*, A, suspended beneath the car-floor, is connected by a system of extra heavy $\frac{1}{2}$ -in. pipes, with soldered joints and special fittings, to the *regulator*, R. The charging of the *receiver* is effected (from either side of the car) by means of hose, connecting the charging lines from the gas station with the *filling-valves*, F (fig. 3162). The gage, G, communicating with the high-pressure pipes connecting the various parts of the apparatus below the car, serves the double purpose of registering the amount of pressure in the receiver at any time and of showing the amount of gas consumed in lighting the car for any given period.

From the *regulator*, R, the gas (with its pressure reduced to about $\frac{1}{2}$ oz. per sq. in.) passes upwards through the car toward the roof. At some convenient point, as in a saloon or locker, a *main cock* (No. 25c, fig. 3169) is placed as shown, whereby the flow of gas to the lamps is controlled.

A $\frac{1}{2}$ -inch pipe is run along the roof, with $\frac{1}{4}$ -inch branches to each lamp or bracket. These *branches* are made by means of special *flanged-tees* (No. 16c, fig. 3177). Where $\frac{1}{4}$ -inch connections are necessary passing downward from the $\frac{1}{2}$ -inch low-pressure line on the roof to brackets or vestibule-lamps, the flanged elbow or *angle fitting* (No. 17A, fig. 3176) is used.

For lamps and methods of suspending and connecting them see *Pintsch gas-lamps* and figs. 3238-40.

Pintsch washers. Figs. 3218-21, etc. These washers are of lead and rubber, in three sizes, and are always used in pairs. The rubber is always placed first on the fitting, the lead outside with the collar inwards. When pressure is brought upon the washer, the lead collar protects the inner edge of the rubber, and the body of the lead washer protects the outside surface of the rubber, and the rib protects the outer edge of rubber. The rubber is entirely enclosed in metal, and protected from the action of the gas, which would otherwise destroy it. The

scored surfaces of the flanges entering into the soft lead make a perfectly tight joint. These washers are used on all classes of flanged fittings, whether high or low pressure.

Pipe. "A tube for conveyance of water, air, or other fluids."—*Knight*. The wrought-iron pipes used for conveying gas, steam, etc., and commonly called *gas-pipe*, is usually meant by compound words beginning with pipe, as below.

- | | |
|--|---------------------------------------|
| See <i>Brake-cylinder pipe.</i> | <i>Running-pipe.</i> |
| <i>Brake-pipe.</i> | <i>Signal-pipe.</i> |
| <i>Cold-air pipe.</i> | <i>Smoke-pipe.</i> |
| <i>Conductors' valve discharge-pipe.</i> | <i>Steam-pipe.</i> |
| <i>Conductors'-valve pipe.</i> | <i>Store-pipe.</i> |
| <i>Deflector-pipe.</i> | <i>Supply-pipe.</i> |
| <i>Discharge-pipe.</i> | <i>Triple-valve branch-pipe.</i> |
| <i>Exhaust-pipe.</i> | <i>Waste-pipe.</i> |
| <i>Guard-pipe.</i> | <i>Water drip-pipe.</i> |
| <i>Hot-air pipe.</i> | <i>Urinal drip-pipe.</i> |
| <i>Injector-pipe.</i> | <i>Urinal ventilating-pipe, etc..</i> |

Pipe-bushing. Fig. 2955. See *Bushing*.

Pipe-clip or strap. Figs. 2935-6. See *Clip*.

Pipe-coupling. Figs. 2941-2. A short cast-iron tube with a thread cut on the inside at each end, which is screwed on the ends of two pipes and used for uniting them together, or uniting one pipe with another object, as a cock or valve. In some couplings the thread at one end is right-hand and the other left-hand, but generally they are both right-hand threads. Also see *Reducing pipe-coupling*.

Pipe-fittings. Figs. 2928-56, etc. The connections for systems of wrought-iron gas, water, and steam-pipes. The more usual pipe-fittings are *bushings, elbows, tees, return-bends* (close or open), *reducers, couplings, nipples, plugs, clips*, etc., which see in Dictionary.

Pipe-reducer. See above. *Bushings, tees* and *conplings* may be and are all so made as to serve as reducers.

Pipe-screw threads. Screw-threads used for connecting wrought-iron pipes together. Such screws are cut "tapered"; that is, the end of the pipe, or the inside of the coupling where the thread is cut, forms part of a cone, so that in screwing up the pipe a tight joint can be made. Pipe-threads are of a V-shape, sharp at the top and bottom, and their sides stand at an angle of 60° to each other. The following is the number of threads per inch for pipes of different sizes. The size is given by the inside diameter, but the actual bore of the smaller sizes is considerably larger than the nominal. The exterior diameter of ordinary gas-pipe is from .27 to .37 inches greater than the inside diameter.

AMERICAN STANDARD SYSTEM OF PIPE THREADS.

Size of pipe.	Outside diam. Ins.	Inside diam. Ins.	Inside diam. Extra strong. Ins.	Inside diam. Double extra strong. Ins.	Threads per inch.	Whitworth's thread.
1/8 in.	.405	.27	.205		27	28
1/4 "	.54	.364	.294		18	19
3/8 "	.675	.494	.421		18	19
1/2 "	.84	.623	.542	.244	14	14
3/4 "	1.05	.824	.736	.422	14	14
1 "	1.315	1.048	.915	.587	11 1/2	11
1 1/4 "	1.65	1.38	1.272	.884	11 1/2	11
1 1/2 "	1.9	1.611	1.494	1.088	11 1/2	11
2 "	2.375	2.067	1.933	1.491	11 1/2	11
2 1/2 "	2.875	2.468	2.315	1.755	8	
3 "	3.5	3.067	2.892	2.284	8	
3 1/2 "	4.	3.448	3.358	2.716	8	
4 "	4.5	4.026	3.818	3.136	8	
4 1/2 "	5.	4.508			8	
5 "	5.563	5.045			8	
6 "	6.625	6.065			8	
7 "	7.625	7.023			8	
8 "	8.625	7.982			8	
9 "	9.688	9.001			8	
10 "	10.075	10.019			8	

(The European standard is the *Whitworth* pipe-thread, which is quite different.)

Taper of Thread 1/4 in. per foot.

Pipe-clip, or strap. Figs. 2935-6. An iron band for fastening a pipe against or to some other object. They are usually single, but sometimes double, for two or more pipes. See *Clip*.

Pipe-support (Baker heater). Figs. 2937-38. A cast-iron stand screwed to the floor, with a receptacle at the top to receive and hold a pipe.

Pipe turnbuckle. See *Turnbuckle*.

Piping (Baker's plan). For heating passenger-cars. Fig. 2957.

Piston. A metal disk with packing, etc., made to fit air-tight and work back and forth in a cylinder. Those shown in this volume are chiefly in connection with *air-brakes*, figs. 1688-1760, to which more detailed reference seems unnecessary. The piston consists of a *piston-head* attached to a *piston-rod*. The *piston follower* or *follower-plate* lies at the back of the piston-head, inclosing between them the *piston packing-rings*, or (in the Westinghouse air-brake cylinders), the *piston packing-leather*, which latter is provided with a *packing-leather expander*. The follower-plate is secured to the piston with *follower-bolts*. All these parts are essentially the same in all the various cylinders shown, and for distinctness should be designated with the name of the cylinder within which they work. The *reversing-piston*, which see, of the Westinghouse 8-in. air-pump, shifts the main steam-valves which admit steam to the cylinder. See also *Triple-valve piston*, etc., of Westinghouse apparatus.

Piston-packing expander (Westinghouse brake). See below.

Piston packing-leather (Westinghouse brake). 12, Fig. 1689, a circular ring of leather used as a substitute for *piston packing-rings*, which see, pressed into the cylinder so as to have an L-section, which is attached to and surround the piston and bears against the inside surface of the cylinder, being pressed against it by a round steel rod called the *piston-packing expander*.

Piston packing-ring. 12-13, fig. 1689. A circular metal ring of rectangular section which is placed in grooves in the edge of a piston-head to make it work air-tight in its cylinder. The rings are turned slightly larger than the cylinder and cut in two diagonally at one point, so that when compressed they will tend to spring open.

Piston-rod cross-head (brake-cylinder). 3, figs. 1693-8.

Piston-rod cup-leather (Westinghouse driving-wheel brake). A circular ring of leather similar to the *piston packing-leather*, which see, used to pack the piston-rod instead of the ordinary gland and stuffing-box of steam machinery.

Piston-rod nut (air-pump). 58, fig. 1689; 68, figs. 1691-2. A screw-nut on the lower end of the piston-rod, which holds the piston on the rod.

Piston-rod packing-gland (air-pump.) 28, Fig. 1689. A metal ring which encircles the piston-rod, and which is forced into the stuffing-box and against the packing, which is then compressed by the *packing-nut* 27. More commonly called a *Stuffing-box gland*.

Piston-rod packing-nut. 1. (air-pump.) 27, figs. 1689, etc. See above. Called *Stuffing-box nut*.

2. A nut which is used for holding the piston-rod cup-leather in its place, which thus makes an air-tight joint in which the piston-rod works.

Piston-rod packing-spring (driving-wheel brake cylinder). A spiral spring serving to compress the *piston-rod cup-leather*.

Piston stuffing-box (air-pump). 56, fig. 1689; 95, figs. 1691-2.

Piston-travel indicator. Figs. 1778-82. A graduated scale abutting against the piston of a *brake-cylinder* and passing through the end of the cylinder so that it can be seen. It shows the maximum movement of the piston since it was last adjusted.

Pit. See *Ash-pit*.

Pitch. 1. (Of a screw.) The advance made by the thread

in one complete revolution, usually expressed by the number of threads in a given space, as (in U. S. and England) an inch. See figs. 5492-8.

(Of a roof.) The ratio of the rise of a roof to the horizontal distance covered.

Pitch-chain. 43 and 44, figs. 401-4. One composed of alternate single and double metallic plates bolted and riveted together sidewise, usually intended to work in the teeth of wheels, shaped so as to accurately engage with the chain. Such chains are sometimes used for *berth-chains*. Figs. 4199, 4208.

Pitch-gear (for pile-driver car). 45, fig. 401-4. See *Pitch-chain* and *driving-chain*.

Pitching-roof. A roof formed of one or more inclined plane surfaces. When the pitch becomes steep, the term is used to distinguish a roof formed of plane surfaces from one formed of curved or arched surfaces.

Pivot. 1. "A pin or short shaft on which anything turns."—*Webster*. *Seat-arm* pivots are inaccurately called *rivets*.

See <i>Deck-sash pivot</i> .	<i>Rocker-pivot</i> .
<i>Lower swing-hanger pivot</i> .	<i>Seat-arm pivot</i> .
<i>Monitor deck-sash pivot</i> .	<i>Upper-berth-rest pivot</i> .
<i>Ratchet-pivot</i> .	<i>Ventilator-pivot</i> .
	<i>Upper swing-hanger pivot</i> .

2. (Of car-door fastener.) The pin on which the hasp turns.

3. (Monitor deck-sash pivot.) E, fig. 4397. Also in figs. 4391-3. The pin held in place by a spring upon which the deck-sash turns.

4. (Of rack-tumbler spring padlock.) 6, fig. 2766. More properly the *key-pin*.

Pivot-bearing. 49, figs. 4806-4966. See *Swing-hanger pivot-bearing* (passenger-car trucks).

Pivoted seat-arm (Cobb's, which see). Fig. 4093. A seat-arm which is attached to the seat-back by a loose pivot, instead of by a rigid connection, enabling the seat-back to be thrown higher without increasing its total width.

Pivoted-seat or seat-cushion. 8, figs. 2452-3a. A seat commonly called an "opera-seat," with the cushion pivoted so as it may be raised to permit easy access. Used in *dining-cars*.

Pivoted seat-back arm. Figs. 4092-3.

Pivot-plate. See *Seat-arm pivot-plate*. *Window pivot-plate*. *Ventilator pivot-plate*.

Pivot spring (Monitor deck-sash pivot). H, fig. 4398. The spring retaining the pivot in its proper place after the sash has been placed in position.

Planished iron. One of the attempted substitutes for *Russia iron*. One of many processes consists of the formation of an oxidized surface on each sheet over and above the surface secured in ordinary working. The oxidized surface is then reconverted into metallic iron, which will enter readily into combination with an oxidizing agent applied throughout. The surface thus given to the sheet is fixed by planishing or hammering until the desired polish is secured. The recent imitations of *Russia iron* have been very successful, but nothing yet made out of *Russia* is quite as good as the original.

Plank. "A broad piece of sawed timber, differing from a board only in being thicker. In America, broad pieces of sawed timber, which are not more than an inch or an inch and a quarter thick are called *boards*; like pieces from an inch and a half to three or four inches thick are called *planks*."—*Webster*.

See *Spring-plank*. *Truss-plank*.

Plank car-roof. More commonly *single-board* roof, which see. See also *Car-roof*.

Planted molding, or bead molding (English). 121, figs. 501-4. American equivalent, *panel-strip molding*, *panel-molding*. In a *panel-strip molding* a small molding which is worked out of the solid material of the *panel*, which see.

Plastered lamp. A lamp with a fixed globe which is fastened to a lamp-frame with plaster of Paris.

Plate. 1. A piece of metal flat or extended in breadth.

See <i>Base-plate</i> .	<i>King-bolt plate</i> .
<i>Berth-rest plate</i> .	<i>Letter-box plate</i> .
<i>Berth-latch face-plate</i> .	<i>Match-plate</i> .
<i>Body-bolster truss-plate</i> .	<i>Mirror-plate</i> .
<i>Bolster-plate</i> .	<i>Name-plate</i> .
<i>Bottom stove-plate</i> .	<i>Notice-plate</i> .
<i>Buffer-block face-plate</i> .	<i>Outside top-plate</i> .
<i>Buffer-plate</i> (Miller).	<i>Outside wheel-piece plate</i> .
<i>Center-plate</i> .	<i>Piston follower-plate</i> .
<i>Chafing-plate</i> .	<i>Pivot-plate</i> .
<i>Chair-arm plate</i> .	<i>Reversing valve-plate</i> .
<i>Corner-plate</i> .	<i>Sash-lock plate</i> .
<i>Coupling-pin plate</i> (Miller).	<i>Seat-arm pivot-plate</i> .
<i>Cover-plate</i> .	<i>Seat-lock plate</i> .
<i>Dead-plate</i> .	<i>Sliding-door-latch plate</i> .
<i>Deck-sash pivot-plate</i> .	<i>Slanting table-leg plate</i> .
<i>Door-button plate</i> .	<i>Stop-plate</i> .
<i>Door-hook plate</i> .	<i>Strike-plate</i> .
<i>Door-sash plate</i> .	<i>Suspending-plate</i> .
<i>Drawbar face-plate</i> .	<i>Table-hook plate</i> .
<i>Drawbar follower-plate</i> .	<i>Table-leg-hook plate</i> .
<i>Drawbar friction plate</i> (street-cars).	<i>Threshold-plate</i> .
<i>Draw-hook plate</i> .	<i>Transom chafing-plate</i> .
<i>Drop letter-box plate</i> .	<i>Truck-bolster chafing-plate</i> .
<i>Face-plate</i> .	<i>Uncoupling-lever plate</i> .
<i>Flag-holder plate</i> .	<i>Uncoupling-lever trunnion-plate</i> .
<i>Follower-plate</i> .	<i>Upper berth-rest plate</i> .
<i>Friction-plate</i> .	<i>Ventilator pivot-plate</i> .
<i>Frieze ventilator-plate</i> .	<i>Vestibule face-plate</i> .
<i>Hopper-plate</i> .	<i>Wheel-piece plate</i> .
<i>Inscription-plate</i> .	<i>Winding-shaft plate</i> .
<i>Inside top-plate</i> .	
<i>Inverted truss-rod plate</i> (street-cars).	

2. (Architecture.) "A piece of timber which supports the ends of the rafters."—*Webster*.

3. (Car-building.) 46, figs. 229-66; 93, figs. 435-73, 539-67. A horizontal piece of timber on top of the posts of a car-body supporting the roof-carlines or rafters. Also sometimes called *side-plate* in distinction from an *end-plate*, which see, which is a similar stick across the end of the car. A *deck-plate* is used to cap the deck-posts of an upper-deck. Main carlines, which see, are sometimes called *tie-plates*. In refrigerator-cars *bogus-plates* (which see) are used.

In figs. 332-5, the term *plate* is misapplied to a *Body side-rail*. See *side-rail*.

4. (Of a cast car-wheel.) Figs. 5348-63. The central portion connecting the hub and tread, sometimes *single-plate*, sometimes *double-plate*. The plate is stiffened by *brackets*. See *Car-wheel* and *face-plate* (steel-tired wheel). Figs. 5259-60 is strictly a *double-plate wheel*, but the term is also commonly applied to the Washburn type of wheels, figs. 5268, 5322, 5349. See *Washburn wheel*.

Plate, or laminated buffing and draw-spring (English). 51, figs. 348-51. A large *half-elliptic* spring which spans the distance between the two *buffer-rods* and takes the buffing strains. It is also connected in the center to the *drawbar* and takes the draft strain.

Plate-facing. 94b, fig. 542. An inside cornice *fascia-board*.

Plate-rod (freight cars). 47, figs. 229-66. A horizontal metal rod which passes through two plates to tie them together.

Plate-washer. Fig. 3716. Usually a wrought-iron *cut washer*, in distinction from a *cast washer*, but also used to designate many forms of large washers or plates serving as double or triple washers. See *Washer*.

Plate-wheel. Figs. 5355-63. A car-wheel of which the center portion is formed of a disk or plate instead of spokes. Varieties are the *single*, *double*, *open* and *combination* plate-wheel. See *Wheel* and *car-wheel*.

Platform (passenger and caboose-cars). 1. 34, figs. 435-73, and *vestibules*, figs. 2419-50. A floor at the end of a car, supported by projecting timbers below the car-body to facilitate ingress and egress. On freight-cars they are

not common, except on cabooses, but narrow platforms are sometimes added for convenience of trainmen. See also *Gould, Janney and Miller platforms*, containing certain special modifications of the platform, which have greatly added to its strength and security.

2. (Pile-driver car.) 27, figs. 401-4. See *Swinging-platform*.

Platform-brace. Fig. 3776.

Platform-car. Figs. 16-19 and 287-97. A *flat-car*; which, if provided with sides, becomes a *gondola-car*.

Platform-chain. Fig. 3804. A chain connecting the inner platform railings, posts and rails, closing the passage way between the platforms of two cars coupled together. It is used only on rear end of last car, and front end of first car when the first car is a passenger-car.

Platform cross-timber. J, fig. 529-30. Also shown in figs. 2296-2300. Correspond to a *platform truss-beam* of the Miller platform and answers the same purpose, viz.: to strengthen the platform and keep it from sagging.

Platform draft-knee. 71, figs. 5654-6. A draft-timber of a street-car.

Platform end hand-rails, panels and brackets. Figs. 3776-9.

Platform end-post, or corner-post. 83, figs. 5654-6. A hollow iron post standing upon the *Platform end-sill* and helping to support the *Platform-hood*.

Platform end-timber, or buffer-beam. 38, figs. 435-73. A cross-timber at the outer end of a car platform. A *Platform end-sill*.

Platform foot-plate. See *Foot-plate*.

Platform floor. 34, figs. 435-73.

Platform-furnishings. Figs. 3771-3813.

Platform-gate. Figs. 3794-3806. A gate used to close the entrance to a platform, in general use only for private cars, suburban cars or street-cars.

Platform-gate panel. Fig. 3775.

Platform-hood. 107, figs. 435-73, and 539-41; and 60, figs. 5654-67. A cover or canopy attached to the end of a car-body, covering the platform. They are made of either wood or sheet-iron. When it consists of an extension of the main roof of a car it is called a *platform-roof*; but when it is a separate part, and fastened to the car-body, as is usually the case on street-cars, it is called a *platform-hood*. A *roof-apron* is a vertical finish of sheet-iron to either a platform-hood or platform-roof.

Platform-hood bow. 108, figs. 435-73, and 62, figs. 5654-67. A bent wooden or iron bow which forms the outer edge of a platform-hood, to which the platform-hood carlines are fastened.

Platform-hood bracket. 65, figs. 5654-67. A bracket or *knee-iron* to connect the *hood* to the *corner-post*.

Platform-hood carlines. 64, figs. 5654-67. Transverse timbers which support the roof of a wooden platform-hood.

Platform-hood ceiling. See *Platform-hood side-piece*.

Platform-hood knee. 64a, figs. 5654-67. An L-shaped piece of wrought-iron by which a platform-hood is fastened to the car-body.

Platform-hood molding (street-cars). 61, figs. 5654-67. A small wooden molding to cover the nails with which the roofing canvas is fastened around the edge. It corresponds with a roof-molding.

Platform-hood post. 109, figs. 435-73, and 83, figs. 5654-67. An upright iron bar or rod attached either to the platform or platform railing, to support a platform-hood. Now rarely used.

Platform-hood side-piece. The end-piece to which the ceiling is attached.

Platform-hood shoulder-carline. 64a, fig. 5663. A hood-carline that lies adjacent to and against the end-plate in a street-car.

Platform-knee, or platform timber (street-cars). 69, figs. 5654-67. A longitudinal piece bolted to the under-

frame and extending out under the platform to support it. Corresponds to the *platform sill* of a *coa ch*.

Platform-lever (Janney and Janney-Miller coupler). 152x, fig. 441. A lever corresponding to the Miller *uncoupling lever*, actuating the *pull-rod* which operates the *catch-lever*.

Platform-lever jaw (Janney-Miller coupler). The fulcrum for the platform-lever.

Platform-lever-pin (Janney coupler). The pin on which the platform-lever pivots.

Platform-plate, or buffer. A steel angle plate bolted to the buffer-stems and overlapping the platform end-sill. When in contact with the like plate of another car, it makes a continuous floor between them. Being pivoted at the platform end-sill, it adjusts itself to all curves of the road. The platform plate also acts as a *buffer*, and is sometimes so called. See *Vestibule*.

Platform-post. 39, figs. 435-67. See below.

Platform-rail. 41, figs. 435-67, 539-41; 84, figs. 5654-67. A wrought-iron bar fastened to the tops of the *platform-posts*, forming a railing on the end of a car-platform. On steam cars an opening is left in the middle of the railing to allow persons to pass from one car to another. The railing is therefore made in two parts, and two platform rails are used. On street cars no such passageway is left, and the rail is in one piece. The outside ends of the platform rails of steam cars are usually carried down to the end-timber, so as to form the *outside post*. On street-cars the outside end is attached to an ordinary post.

Platform-railing. Figs. 3771, etc. An inclosure consisting of iron posts and rails on the end of a platform of a car to prevent persons from falling off. See above.

Platform railing-chain. 42, figs. 444, 3804. A chain connecting the two sections of the platform-rails of a passenger-car. Commonly used in service on the rear platform of the rear car only.

Platform-roof. 103, figs. 435-73. That portion of a car-roof which projects over the platform. See *Platform-hood*.

Platform-roof carline. 104, figs. 435-73, 539-41. See *Carline*.

Platform-roof end-carline. 105, figs. 435-73, 539-41. See *Carline*.

Platform safety-gate. 77, fig. 5654. A gate to close the entrance on one side of a street-car, to prevent passengers from getting on or off on the side of the double track. See also *Platform-gate*.

Platform short-sills. 37, figs. 435-73, 539-41. Short longitudinal pieces of timber, *not* extending under the car proper, which are framed into and bolted to the end-sills and platform end-timbers of a passenger or street-car to sustain the floor of the platform. The longer timbers which extend under the body of the car proper are called *platform-sills*.

Platform-sills. 35, figs. 435-541 and 69, figs. 5654-67. Pieces of timber attached to the bottom of a car-frame at each end outside of the draw-timber, and projecting beyond the end of the car to support the platform. They extend usually from the platform end-timbers to the bolster, or, in street-cars, to one of the transverse floor-timbers. See above.

Platform steps. 45, figs. 435-541 and 74, figs. 5654-8. The stairs at each corner of a passenger or street car which afford the means of ingress and egress. Forms of steps have been introduced, but are not in general use, which are folding or extensible, being dropped down into position when the car is stationary, and removed or elevated when the train starts. In modern passenger-cars the platform-steps consist of usually three and sometimes four separate steps below the platform. The steps being of wood are often called *box-steps*. On street-cars, one step only is used, and it is commonly made of plate-iron. See *Vestibuled platforms*, figs. 2419-50.

Platform step-rod. 76, fig. 5656.

Platform sub-sill (street-cars). 72, fig. 5654. A sub-end-sill, to which the platform is hung; it makes part of the riser of the step from the platform into the car.

Platform tail-lamp. Fig. 3330-2.

Platform tie-rods. 162, figs. 463; 193, fig. 571. Horizontal rods which pass through the *platform end-timber* and end-sill or body-bolster, for the purpose of holding them and the other portions of the frame of the car securely together.

Platform-timber. See *Platform-sill*.

Platform-timber band (street-cars). 87, fig. 5654. A band made of plate-iron, which covers and embraces the outer end of a platform end-timber. Called also a *Buffer-band*.

Platform-timber, or platform-sill, clamp. 70, fig. 5664. A U-shaped iron clamp or bolt, with which a platform-sill is fastened to the end-sill of a street car.

Platform trap-door. 1. (Shown in fig. 2438.) A door which covers the space occupied by the steps, and thus extends the platform out to the side of the car. It is used on officers' or other private cars, and invariably with the Pullman extended vestibule.

2. A door used in cabooses to serve the purpose of a water-closet.

Platform-truss. Fig. 1451. A truss transverse to the car-body and under the end-sill, to help support the draft-timbers and platform-sills. It is not frequent.

Platform truss-beam (Miller platform). 22, figs. 2290-2. A short transverse piece of timber attached to the outer ends of the draw-timbers inside the platform end-timber, which forms the bearing of the *platform truss-rods*.

Platform truss-rod (Miller platform). 23, figs. 2290-2. A rod fastened at one end to the body-bolster or center-sills, which then passes through or over the end-sill and from there downward to the platform truss-beam. Its use is to support the platform and prevent it from sagging.

Play. See *End-play*. *Lateral motion*.

Plow. See *Snow-plow*.

Plow suspension-beam (snow-plow and flanger). 202, figs. 414-18. A heavy timber, one end of which is strapped rigidly to one end of a *flat-car*, while the other end sustains the plow, hung over the other end of the *flat-car*. The beam is swung in a stirrup near the end to which the plow is attached, and this stirrup may be raised and lowered, by compressed air, which lifts the beam and plow at the will of the locomotive engineer who is pushing the plow.

Plug (pipe-fittings). Fig. 2934. A short solid, metal cylinder, with a screw on the outside and a square or hexagonal end to take hold of with a wrench, screwed into the end of a pipe or hole in a plate, to close the opening. See also *Basin plug*. *Four-way-cock plug*.

Plumbago. Graphite; one of the forms of pure carbon from which pencils, etc., are manufactured. When pulverized, plumbago is an excellent lubricant, especially under heavy loads, and *plumbago oils*, prepared so as to hold the plumbago in permanent suspension, are among the most efficient of all lubricants.

Plush. "A species of shaggy cloth or stuff with a velvet nap on one side, composed regularly of a woof, of a single thread and a double warp; the one, wool of two threads twisted, the other of goat's or camel's hair. But some plushes are made wholly of worsted, others wholly of hair."—*Webster*. Plush is used in car-building chiefly as a covering for upholstered seats, for which it is almost invariably used.

Pocket. 1. (Sleeping-cars.) 32, figs. 2409-12. A receptacle for the clothing and small baggage of occupants of sleeping-berths. They are known as the *head-board pocket*. It is shown in fig. 2412.

a receptacle to hold anything in its place. The main pockets of a car are the *body-post*, *corner-post* and *right* and *left hand body-brace pockets*, figs. 703-10, which are castings fastened to the upper side of the sill and the under side of the plate, to serve instead of mortises to receive the posts and braces. Brace-pockets are distinguished as *right* or *left hand*, according to the inclination of their top to a person standing facing the car. *Double-brace pockets*, figs. 696-8, to receive two braces inclining in opposite directions, are also made, often with a receptacle in the middle for a post. A *post-pocket* is a receptacle for the *posts*, door-post or *corner-post*, figs. 711-13. A *stake-pocket*, figs. 914-15, of a flat or gondola car should be distinguished from a post-pocket, it being bolted to the outside on the side of the side-sill. Similar uses of the term are *leader-brace pocket*, *pilaster-pocket* and *mast-pocket*, for pile-driver and derrick-cars. See also *Drawbar-spring pocket*. *Draft-timber pocket*.

Pocket-hinge. Fig. 2608. See *hinge*.

Pocket-strap or yoke (draw-bar attachment). 5, figs. 2293-5. The U-shaped strap or yoke that incloses the draft spring and follower-plates.

Pole or hand-straps. Figs. 3630-3. Straps to which people who are required to stand may cling and keep from falling as the car starts and stops. See *Hand pole*.

Pole or hand-strap brackets. Figs. 3626-9. For street cars from which the *straps* are suspended. (See above.)

Poling-car. See *Push-pole car*.

Pooley car-coupler. Figs. 2191-98a.

Pope gas-light system. A system of gas lighting used in England and recently introduced into this country by the Consolidated Car-heating Company.

Pop safety-valve. A valve set with a spring so as to open suddenly with a wide opening at a fixed pressure; hence the name.

Port. An opening in a valve for the passage of steam. See *Steam-port*.

Portland Company's snow-plow. Figs. 410-13. A push-plow that has done good service in New England and Canada. The frauing, which is unusually heavy and compact, is shown in the engravings.

Post (of a truss) (for pile-driver car). 26, figs. 401-4. A piece of timber or metal set upright and intended to support something else, as the *posts* of a house; the *posts* of a door; the *posts* of a gate; the *posts* of a fence; the *posts* of a bridge.

See *Body-post*. *Platform-hood post*.

Body queen-post. *Platform-post*

Break-beam king-post. *Queen-post*.

Corner-post. *Sub-post*.

Deck-post. *Truck-bolster king-post*.

Door-post. *Truck-frame king-post*.

Hand-rail post. *Truck-frame queen-post*.

Hat-post. *Window-post*.

Lever-frame post.

Postal-car. Figs. 142-8, 599-615. A car for carrying mail matter, and fitted up with boxes and other conveniences for assorting and distributing it. Nearly all mail matter is now assorted *en route*.

A distinction has been attempted between *mail cars*, used solely for carrying mails and distributing *postal cars*, but the distinction is not well observed, and so-called mail cars, except as compartments in combination baggage cars on minor lines, are little used. The word *mail* is invariably used in speaking of a combination *Baggage and mail-car*.

The railway post-office is an English invention, separate postal cars having been used as early as 1837. The present American postal-car service was introduced by George B. Armstrong in 1864, and the first postal cars were run between Chicago and Clinton, Ia., and at about the same time between Washington and New York. Postal cars are owned by the railway companies, but when in use are under the exclusive control of the post-office authorities. They are usually built after plans and specifications approved by the Superintendent of Railway Mail Service, in whose district they are to run. See also *Mail van* (English).

- Postal-car chandelier.** Figs. 3266, 3273, 3288-90. See *Chandelier*. A variety of postal-car lamps and chandeliers have been introduced with the object of giving a brilliant light when and as desired. Pintsch gas lamps and oil lamps with the *acme-burner* are in special favor.
- Postal-car furnishings.** Figs. 3814-36.
- Postal-car lamp-chimneys.** Figs. 3412-13. See *Lamp-chimneys*.
- Postal-car side-lamp.** Figs. 3288-90. See *Postal-car chandelier*.
- Post-bracket (open street-car).** 65a, fig. 5959. The cast-brackets between the posts and plate on the side.
- Post cross-bar (open street-car).** 251, figs. 5659, 5662. A bar or plank connecting the posts at the ends of a transverse seat. They are under the seat.
- Postal-lamp.** See *Postal-car-lamp*.
- Post-molding.** 26, fig. 5654.
- Post-office car.** See *Postal car*.
- Post parting-strip.** 24, fig. 5656. See *Sash parting-strip*.
- Post-pocket.** An iron casting which is attached to the top of the sill of a car to receive and hold a post in distinction from a *stake-pocket* which is bolted to the outside of side-sill. Such pockets are more commonly used with stock-cars. See *Pocket*.
- Post refrigerator car.** One of the class of cars using salt and ice for refrigeration.
- Pot.** See *Fire-pot*.
- Potter drawbar.** A form of *link-and-pin drawbar* with a pair of ears on each side. To one pair of these a link is attached permanently, to the other pair a pin, so that it can be raised and lowered, but not removed. To the center an ordinary link can be coupled. The drawbar was named after the inventor.
- Pouch-hook (postal-cars).** Figs. 3814, 3833-6. Hooks used for suspending mail-bags while assorting the mails. They are usually strung loosely upon a rod, and are distinguished as *square-eye* or *round-eye*, according to the section of the rod. Some forms are permanently attached to the side of the car. See *Ormolu hook*, a term which should designate simply color and finish, but appears to be used to designate a difference of form.
- Pouch-rack.** 5, figs. 599-604. A rack built of standards and horizontal rods to which the pouch-hooks are attached and which support the pouches or bags while mail is being distributed into them.
- Poultry-car.** Fig. 8. A car specially designed to carry live poultry. The car shown is provided with arrangements for feeding, watering, and by removing intermediate floors may be arranged to carry geese and turkeys instead of chickens.
- Press.** See *Seal-press*.
- Pressure-bar.** (Gould buffing apparatus.) 40, figs. 2297-9. A stiff iron bar of a cross-shaped (+) cross-section, which connects the drawbar to the *buffer-spring*, so that the draft-spring re-enforces the buffing-spring and the buffing-spring takes up part of the pull on the drawbar, thus relieving the draft-spring. The pressure-bar also forces out the buffer-stem and plate when the drawbar is pulled out, thus maintaining a continuous platform between the cars.
- Pressure-bar cylinder and piston.** (Leonard hydrostatic buffer.) F, J, figs. 2351-4. A cylinder which receives the pressure-bar piston which is a part of the pressure-bar turned to fit the cylinder. See *Hydrostatic buffer*.
- Pressure-gage (Pintsch gas-lighting).** Fig. 3164. A gage usually placed in the saloon. It registers atmospheres and not pounds, for convenience in computing the volume of gas in the tank.
- Pressure-regulator (Gold's car-heating).** Fig. 3012. A valve designed to regulate the delivery-pressure of steam, etc. It depends entirely upon the elasticity of springs, the pressure of which can be gaged or regulated by screw-studs that bear upon one end of the springs. In the Gold pressure-regulator there is a spring on each side of the valve.
- Pressure-regulator.** (Pintsch gas-lighting apparatus.) R, fig. 3160 and fig. 3168. The valve by which the pressure of the compressed gas is reduced for consumption. The pressure-regulator is one complete fixture, adjusted by the maker. Names of the principal interior parts are *diaphragm*, *diaphragm connecting-rod*, *diaphragm-lever*, *regulating-valve*, and *dust-arrester*. See *Pintsch system of gas-lighting and regulator*.
- Pressure-retaining valve (Westinghouse brake).** A valve for use on long and steep gradients, provided with a weighted valve connected with the discharge port of the triple valve. It is controlled by a small handle, which, if turned in one direction, permits the air to escape freely, and, if in the other, forces it to pass under the weighted valve. In descending long gradients the weighted valve retains a pressure of 15 lbs., which keeps the train under control when the brakes are released to recharge the reservoirs. On slight grades or on a level the cock is turned to permit the air to escape freely without raising the valve. This valve does away with the necessity of using "straight-air" (which see) on such grades.
- Profile carline.** 100, figs. 435-73. A carline, which see, extending from one plate to the other, bent to conform to the shape of the clear-story. They are, of necessity, always *compound carlines*, which see, shown in section in figs. 1248-9.
- Priming (painting).** The first coat in car-painting. Usually a pure thin oil put on hot, at about 150° F. or less. A thin *drier*, which see, of red lead or borate of manganese, is used with it. The next coat is the scraping filling-coat or *rough stuff*, which see. See also *Painting*.
- Private car.** Figs. 119-22, 180-1, 194-202. Either an *officers' car* or *excursion car*, which see.
- Private lock (English).** 182, fig. 501. A door-lock universal in passenger service, which can only be operated by a tapered rectangular hardened steel key, which is carried by all passenger trainmen, and most habitual travelers. One key will open any "private lock."
- Propelling-lever, or hand-car lever (lever hand-car).** 19, figs. 5592-00. The main lever to which power is applied.
- Propelling-lever brace-rods (lever hand-car).** 25, figs. 5599.
- Protection cap.** A *lamp-jack*.
- "Protection" cuspidor.** Figs. 2863-4. One with a large mat fastened to it to prevent overturning. See *Cuspidor*.
- Pull.** "A catch or lip upon a drawer, door or window, by which it is pulled open."—*Knight*.
- | | |
|------------------------|---------------------------|
| See <i>Door-pull.</i> | <i>Seat-pull.</i> |
| <i>Drawer-pull.</i> | <i>Sliding-door pull.</i> |
| <i>Deck-sash pull.</i> | <i>Window-blind pull.</i> |
- See, in engravings, *Furnishings, door, postal car and window*.
- Pulley.** "A wheel with a grooved, flat or slightly convex rim, adapted to receive a cord or band which runs over it. Its function is to transmit power or change the direction of motion."—*Knight*. A *sheave* is a pulley-wheel in a block, but *sheave* and *pulley* are used as almost synonymous terms. See *Sheave*.
- | | |
|-----------------------------------|-------------------------------|
| See also <i>Bell-cord pulley.</i> | <i>Pile-hoisting sheave.</i> |
| <i>Berth-chain pulley.</i> | <i>Side-pulley.</i> |
| <i>Chain-pulley.</i> | <i>Window-curtain pulley.</i> |
| <i>Hammer-rope pulley.</i> | |
- Pull-hook or deck-sash opener.** Fig. 4376-80. A shaft with a small hook on the top for opening deck-sashes. Also called *ventilator-staff*.
- Pull-iron.** 58, figs. 229-66. A roping-staple. A U-bolt passing through the side-sill for the purpose of attaching ropes in switching. A *push-pole corner-iron*, 191, is a lower corner-plate with a socket cast or forged thereon,

and in which the end of a pole is inserted for pushing instead of pulling the car.

Pullman car. A name strictly applicable only to cars operated by the Pullman's Palace Car Company, but in common usage not unfrequently applied to "palace" sleeping, parlor or drawing-room car built after the same designs as those adopted by Pullman's Company, the Pullman cars having been the first of this class introduced on a large scale and in modern style of finish, and being much more in use than any other class of parlor or palace cars. Included among Pullman cars are sleeping-cars, parlor or drawing-room cars, dining-cars and combination-cars, which see. Late designs differ from the earlier designs in the use of a "buffet," etc., and in being finished in much lighter-colored woods than the former dark styles prevalent. The latest pattern of passenger-cars built by Pullman's Company are shown in the following illustrations:

Dining-cars, figs. 107, 109-10.

Parlor-cars, figs. 115-17.

Private-car, figs. 121-2.

Sleeping-cars, figs. 123-26, 129-31.

Smoking-car, etc., figs. 133-4.

The most marked changes shown in these figs. are the arched deck-ceiling, the half-round or oval deck-windows and the elaborate decorations. The plans of Pullman cars are shown in figs. 182-197. *Framing*, figs. 512-22, 531-8; *Sleeping-car berth*, figs. 2409-12; *Vestibules*, figs. 2424-5, 2437-50; *Truck*, figs. 4963-6.

Pullman extended-vestibule. Figs. 2424, 2437-41. A vestibule which incloses and utilizes the whole of the platform of a car. It is provided with equalizing devices above and below and employs the same frictional resistance to prevent lateral oscillation as the earlier type. The improvements are chiefly confined to the platform inclosure. Windows are introduced at the end of the car in this construction which permits of better ventilation. The platform may be utilized, the steps being covered with trap doors so that the entire area of the platform is available. A single door (7) may be used at the sides and avoid the double folding doors of the other pattern.

Pullman passenger-car trucks. Figs. 4963-6. Nearly, if not all, Pullman cars are equipped with six-wheeled trucks, similar to the illustration, which is the latest standard at this writing, 1894.

Pullman sliding-door (street-car). Fig. 5665.

Pullman system of water pressure. Figs. 3534-48. This system of water supply under air-pressure replaces the old method of using pumps for raising water for wash purposes in sleeping cars. The system consists of forcing water into the wash-bowls by air-pressure taken from the brake system as applied to cars. When the auxiliary air-brake reservoir is filled with air to a pressure of 60 lbs., an *Air-governor*, **Q**, admits air through a *Drip-cup* into an *Air-tank*, 36 inches long by 22 inches in diameter. This is a storage tank for use when cars are disconnected from the locomotive. The pressure carried is about 75 lbs. From this tank the air passes through a *reducing-valve*, **R**, (set for 22 lbs. pressure), into the water-tank. At the end and center of the tank is a special *three-way valve*, **P**. This valve performs the triple service of admitting water and air, and also allowing the air to escape when the tank is filled with water. The valve, **P**, is operated from inside the car by a stem, marked **W**, to which is attached a pinion and gear. The air before passing into the water-tank passes through a *Check-valve*, which is to prevent the water in the tank from backing into the air-pipes; the water being forced out of the tank passes through a strainer or screen, **T**. This screen is closed by the valve, **Z**, which when operated by the stem, **W**, allows the water to pass through the screen in such a manner that the water passing through the strainer is led by pipes to

the different wash-stands and closets. One pipe passes to the heater and the water goes through a check-valve, **I**, and a shut-off valve, **H**, when it enters the copper coil which encircles the fire magazine. The hot water passes by gravity to a tank marked **N**, which has a connecting pipe back to the coil. Through these pipes there is a constant circulation from the heater which keeps the water hot. A connection is made from the top of this tank to the various washstands and bath-tub where hot water is required. At each end of the car a fire hose is placed which can be used at a moment's notice, under the tank pressure. At the top of tank **N** is a safety-valve marked **M**. The water-tank is insulated to prevent the water freezing in cold weather. This insulating box contains about 20 ft. of heater pipe which is connected with the heating pipes of the car.

Pullman-vestibules. Figs. 2424, 2437-48. To the Pullman company belongs the credit for having introduced and perfected the vestibule. There are two types, the original which encloses the platform exclusive of the steps; and the *Pullman improved extended-vestibule*, which encloses the platform steps, to the full width of the car. The peculiarities of the Pullman-vestibules is explained under *Vestibules*, which see. The frictional resistance of the Diaphragm face-plates to oscillation under opposing spring pressure is accomplished by an ingenious mechanism shown in the figures. The *plate equalizer*, shown in figs. 2437-45, is intended to keep the upper part of the face-plate thrust out and adjusted to its companion plate. It is shown in the hood and plan and the parts are numbered from 23 to 29 inclusive. The two sides are equalized at the top by the face-plate equalizing lever (27), and at the bottom by a platform-equalizer (51). Another adjustment of the vestibule face-plate is the Buhoup vestibule equalizer-kicker, a mechanism forming a part of the Pullman vestibule. It is shown in figs. 2442, and in more detail in fig. 2440, and the parts are numbered 45 to 52. The object of this device is to have the bottom of the vestibule plate follow the movements of the draft rigging, and by a system of levers it is so arranged that whether the drawbar be in tension or compression the bottom of the face-plate and buffers are forced out, in the former case to prevent any opening between the two opposing face-plates, and in the latter case to aid in resisting the buffing effect caused by sudden stops or collisions. When there is a pull on the coupler (45), the spring (46) is compressed; the drawbar-horn (49) is forced against the combination yoke (48), which impinges against the buffer stem (52) and spring (50); when the coupler is under compression the spring (46) is compressed and the bolt below the bar is forced against the yoke (48) and forces out the buffer stem (52) as before. So that in case of collision the shock is met by the combined resistance of the drawbar and buffer-springs, and in tension the buffer and face-plates follow up any movements of the drawbar, thus insuring frictional contact and resistance at all times between the face-plates of the cars coupled together.

Pull-ring. Figs. 4342-50. A metal ring with a screw attached by which it is fastened to any object, as a sash, drawer, etc., to take hold of in opening it. Chiefly used for *deck-sashes*.

Pull-rod (Janney coupler). 141, fig. 2301. The rod connecting the uncoupling-lever with the catch-lever, also called an *uncoupling-rod*.

2. (English brake-gear.) Any rod transmitting tension when the brake is applied.

Pull-rod button (Janney coupler). The "T" button upon the end of the *pull-rod*.

Pull-rod carry-iron. 146, fig. 2301. A carry-iron for an *uncoupling-rod*.

Pull-rod plate (Janney coupler). A small chafing-plate on the Janney *platform knee-timber* through which the pull-rod passes. A pull-rod carry-iron.

Pull-up brake. Fig. 16.

Pump. 1. (Westinghouse brake.) Figs. 1691-2. An *air-pump*, which see.

2. (Wash-rooms.) Figs. 3481-2, and 9, fig. 3468. A *basin-pump*, which see.

Pump drain-cock (Westinghouse brake). 105, figs. 1691-2.

Pump-governor (Westinghouse brake). Figs. 1716, 1755. An attachment designed to automatically cut off the supply of steam to the pump when the air-pressure in the main reservoir exceeds a certain limit, usually about 90 lbs. The governor not only prevents the carrying of excessive air-pressure, but also causes the accumulation of a supply of air in the main reservoir while the brakes are applied, which insures the release of the brakes, without delay. It also obviates the unnecessary working of the pump, when the desired air-pressure has been obtained.

Punch. See *Bell-punch*.

Purlin. 83, figs. 229-66, etc., 205, figs. 97-101. A longitudinal piece of timber over the rafters, extending from one end of the car-roof to the other, to which the roof-boards are fastened. Sometimes called a *roof-strip*, but the latter more correctly applies to strips sometimes used above the purlins, as **E**, fig. 2381.

Push baggage-car. A light *lorry-car* used at station for moving baggage or freight from one train to another.

Push-bar. Figs. 1397-8; 40, figs. 2297-9. (Gould coupler, etc.) A *pressure-bar*.

Push-bar (Westinghouse brake). 3, figs. 1726, 1728-9, etc. Usually called *push-rod*. A compression-bar which butts up against the piston of a brake-cylinder, being guided by a *Hollow piston-rod*, which see, in such manner as to transmit the pressure of the piston when the air-brake is used, but to simply move away from the piston, without moving the latter, when brakes are applied by hand.

Push-block. 191, fig. 229-66, etc. See *Push-pole corner-plate*.

Push-car, or lorry-car. Figs. 5583, 5589, 5601-3. A four-wheeled car, also called *lorry-car*, used to carry materials and tools, moved or pushed by hand. Also see *Ferry push-car*.

Push-down (H. & K. reclining car-seat). Figs. 3922-5. A thumb-latch, which, when pushed down, permits the seat-back to be tilted to a reclining position.

Push-pole. A pole or wrought-iron tube, which is used as a strut to span diagonally the distance between the corners of a locomotive and a car, standing on two parallel tracks, and which is used to push such car without switching the locomotive on to the same track as the car occupies.

Push-pole car. A flat car with a push-pole attached to the side-sill so that it can be used in "poling" cars. The pole of former days has become a wrought-iron tube, and one end is pivoted to the side-sill of the car. A post and lever is attached to the pivoted end so it can be swung out over the side track by the operator who stands upon the *Push-pole car*. See *Push-pole*.

Push-pole corner-plate or iron. 191, figs. 229-66. A plate for inserting poles or bars in switching to enable the car to be moved from the side by an engine on a parallel track. It is usually a cavity cast upon the lower corner-plate, and not a separate attachment. A *Roping staple*, which see, serves the same purpose for the use of a rope.

Push-rod (Westinghouse freight and tender brakes). See *Push-bar*.

Push-rod (Westinghouse freight-brake). The rod which butts against the brake-cylinder piston and transmits its thrust.

Putty. A mixture of linseed oil with whiting, which latter is chalk finely pulverized. Water is sometimes added in adulteration, causing the putty to stick to the fingers,

and making it hard and brittle when dry. *Panel-putty*, used for filling nail holes in car work, is an extra quality made from whiting, white lead in oil, japan or varnish, and a small quantity of turpentine. The whiting is used merely to prevent the white lead from sticking to the fingers, and no more than necessary for this purpose is required. This putty forms a hard cement which does not shrink. When dry it can be rubbed down with pumice-stone or dusted with sand-paper. *Glycerine putty* is made of good thick glycerine and white lead or litharge. It hardens in 15 to 45 minutes, and stands water and acids.

Pyramidal hopper bottom. Figs. 310-15. See *Box hopper-bottom*.

Q

"Q & C" brake-slack adjusters. 1. Figs. 1771-4. An adjuster by which the slack is taken up by washers or small plates, which drop into the space left by any lost motion in the rod.

2. Fig. 1775. A combination of a ratchet and pawl, which ratchet wheel is also a gear wheel, which engages in a pinion, that is the female screw sleeve of the *cylinder-lever connecting-rod*. See *Brake-slack adjusters*.

Quadrant. A piece of metal curved in the form of the arc of a circle. See *Sector*. See also *Deck-sash quadrant*, figs. 4389-90. *Lever-quadrant* (Eames ejector). Fig. 1668.

Quadruple coil nest-spring. Fig. 5254. A rarely used *spiral-spring*.

Quadruplet (of elliptic springs, which see). Figs. 4947-8. Four springs side by side acting as one.

Quarter-light, or side-light (English). 137, figs. 501-4. American equivalent, *window*. In a carriage, the window in the body as distinguished from the windows in the doors. The quarter-lights, in English practice, are always fixed, but on the continent of Europe they are invariably made to fall or open, and this is also the case with the vehicles made in England and exported to warm climates.

Quarter-light molding, or glass-frame stile (English). 142, fig. 501. The upright member of the fixed window framing. The glass is very generally fitted direct to the body, a strip of rubber being interposed, and the molding screwed on outside, keeping the whole in position.

Quarter-light panel (English). 126, fig. 501. A panel on the outside of the body, placed above the window. Other exterior panels are *quarter-panel*, *waist-panel*, and *bottom side-panel*. Interior panels are the *partition panel*, *inside top-light panel* and *roof panels*.

Quarter-light pillar (English). 110, figs. 501-4. A part of the body framing of a carriage. A vertical post forming one side of the window aperture.

Quartette (elliptic spring). Also called *quadruplets*, which see.

Queen-post (of a truss). One of a pair of vertical posts against which the *truss-rod* bears. When one post only is used, it is called a *king-post*, which see. Such posts are used for the *body truss-rods* under car-bodies and occasionally trucks. See *Body queen-post*. *Inverted body queen-post*. *Truck-frame queen-post*.

Queen-post stay. A bar attached to a queen-post to stay it laterally. See *Body queen-post stay*.

Quick-acting passenger triple-valve (Westinghouse air-brake). Fig. 1706. See *Triple-valve*.

Quintuplet (of elliptic springs, which see). Five springs side by side, acting as one. 30, figs. 4942-3.

R.

Rabbet. "A rectangular groove made longitudinally along the edge of one piece to receive the edge of another. It is common in paneling, and in door-frames for the door to shut into."—*Knight*. *Rabbet* is a corruption of the word *rebate*.

Rabbeted-lock. "A kind of lock whose face-plate is sunk within a rabbet cut in the edge of a door."—*Knighl*. See *Lock*.

Race-horse box (English). American equivalent, *horse-car*. A four-wheeled covered vehicle adapted to run on passenger trains and to carry valuable and excitable horses. The mangers, stalls, etc., are carefully padded, and a compartment provided for the jockey, who can reach the horse's head. See also *Horse-box*.

Rack. 1. "A frame for receiving various articles."—*Webster*. See *Basket-rack*. *Bible-rack*. *Brush and comb rack*. *Card-rack*. *Head-board rack*. *Towel-rack*.

2. "In *machinery*, a rectilinear sliding-piece, with teeth cut on its edge for working with a wheel."—*Brande*. A *ratchet*, which see. See also *Beveled-rack*. *Sash-lock rack*. *Slewing-gear rack*.

Rack-catch (for head-board). A small "cupboard catch" to hold the head-board pocket closed.

Radiating draft-bar (street-cars). 88, fig. 5654-6. A draw-bar pivoted so that it may be swung oblique to the car length over a draw-bar sector. A *center-draft draw-bar* is an example of a radiating draft-bar.

Radiator. 1. Baker and other steam and hot-water heaters. Fig. 2943-4; shown in *plan*, fig. 2997. A piece of iron pipe bent into a U-shape under the seats of a car, through which the hot water or steam circulates.

Radiator-stand (Baker and other heaters). Figs. 2937-8. A support for a *radiator*.

Rafter. A timber to support the roof of a car, which extends *part way* across the top, either from the plate to the ridge of the roof, or to the base of the deck-side only, as 101, figs. 435-73, etc., and figs. 1215-6. When such timbers extend all the way across they are called *carlines*. See *Main-rafter*.

Rail. "The horizontal part in any piece of framing or paneling."—*Webster*.

See <i>Belt-rail</i> .	<i>Hand-rail</i> .
<i>Bottom-rail</i> .	<i>Lower seat-back rail</i> .
<i>Deck bottom-rail</i> .	<i>Middle door-rail</i> .
<i>Door-case intermediate rail</i> .	<i>Panel-rail</i> .
<i>Door-case top-rail</i> .	<i>Parting-rail</i> .
<i>Door rail</i> .	<i>Platform-rail</i> .
<i>End-rail</i> .	<i>Sash-rail</i> .
<i>Fender-rail</i> .	<i>Seat-back rail</i> .
<i>Top end-rail</i> .	<i>Seat-bottom rail</i> .
<i>Top side-rail</i> .	<i>Seat-rail</i> .
<i>Upper belt-rail</i> .	<i>Wainscot-rail</i> .
<i>Guide-rail</i> .	<i>Window-blind rail</i> .

Railing. "A series of rails; a fence."—*Webster*. See *Platform-railing*. *Step-railing* (street-cars).

Railing-chain. See *Platform railing-chain*.

Railroad-car. See *Car*.

Railroad-lantern. Figs. 3352-62. A lantern used in large numbers by trainmen and other employes of railroads. A variety of patterns exist and are shown.

Railroad-padlocks. Figs. 2760-72. See *Padlock*.

Rail roof-molding (street-car). 160, fig. 5656, a roof *deck-sill molding*. Its use is to make a tight joint between the roof boards and *deck-sill*, or upper-deck bottom rail.

Raised-roof. An upper-deck or *clear-story*, which see.

Ranges and cook-stoves. Figs. 3106-8, and also 3061-3105. A *range* is a fixed and more elaborate cook-stove attached to the wall, and, in houses, usually built in with brick so as to need no stove-pipe to connect with the chimney.

Racoul journal-box. Figs. 5165-6. A journal-box with a U-shaped bar called the *yoke* or *bail* attached to the box so as to embrace and hold the lid, which latter carries an *end-stop* so as to dispense with a collar on the axle. In much favor for narrow-gage cars, such as plantation, mine, and logging-cars. In very limited use on

ing or (more commonly) restraining motion. See *Brake ratchet-wheel*. *Winding-shaft ratchet-wheel*. An *undulating ratchet* is one having no sharp edges, so that the ratchet-catch will slide over them without removal on the application of force, as in deck-sash pivots, figs. 4391-2.

See *Bottom-ratchet*. *Uncoupling-lever ratchet*. See also *deck-sash pivot*, figs. 4385-8, 4391-3, 4397-8, for various forms of ratchets and attached parts used in connection therewith.

In most of the English dictionaries the term ratchet is defined not only as the serrated edge, but also as the dog or pawl which engages therewith. This definition however, is believed to be an error, which has been copied from one dictionary to another, and which does not correspond with practice in mechanical work, at least as respects American practice, which latter seems to confine the use of the term *ratchet* to the serrated edge only and does not designate the *pawl* also as a ratchet.

Ratchet-burner (for lard oil). Fig. 3396. One in which the wick is moved up and down by a pointed wheel engaging in it, like mineral oil burners.

Ratchet-wheel. See *Brake ratchet-wheel*. *Winding-shaft ratchet-wheel*.

Rattan car-seat. Figs. 3943-6, 3968-9, 3980-3. See *Car-seat*.

Rattan-seating (canvas-lined). Fig. 3942. See *Canvas-lined*.

Rave. 15A, figs. 5595-7. A vertical side-piece to the frame of a wagon-body or other vehicle. The term is applied to such parts on hand-cars (the raves being also called *seat-risers*), but not to other railroad cars, although literally applicable, for instance, to the sides of a gondola-car.

Reach. See *Extension-reach*.

Rear foot-rest (Hartley reclining-chair). Figs. 3993-9. A foot-rest for the benefit of the occupant of the chair in the rear. See *Foot-rest*.

Rebate. "In architecture, a groove or channel sunk on the edge of a piece of timber."—*Webster*. Usually written *rabbet*, which see.

Receiving-valves (*upper and lower*), (air-pump). 31 and 33, figs. 1689. Puppert valves, which see, at the top and bottom of the air-pump cylinder, to admit the air.

Receiver (Pintsch system). Figs. 3160, 3165. A cylindrical steel tank, with rivetted and soldered seams, adapted to receive and retain gas at high pressures. The sizes vary in diameter from 16½ ins. to 20½ ins., and in length from 6 ft. 1 in. to 9 ft. 6 ins. According to requirements, cars are equipped with from one to four receivers, connected by ¼ in. high pressure piping, etc. See *Pintsch gas apparatus*. Each receiver is fitted with a special valve, 53b, (figs. 3166). See *Holder fittings*.

Receiver filling-valve (Pintsch gas-lighting). F, fig. 3160; figs. 3161-2. A valve of peculiar construction for the admission of the compressed gas to the receiver, so that it can be transmitted to the regulator for consumption.

Receiver-valve (Pintsch gas-lighting). B, fig. 812; fig. 817. The cock attached to the recipient to connect it with the filling-valve or the regulator, as desired.

Reclining-chair. Figs. 3996-9. A chair, the back of which can be inclined to almost any angle, and which is provided with leg and foot rests. The Horton is another design.

Reclining car-seat. Figs. 3922-5, 3974-6. A car-seat, the back and cushion of which can be tilted into a comfortable reclining position, and which, together with a leg and foot rest, make a seat in which people try to sleep. They are always divided by a division-arm and intended for two persons.

Recommended Practice. Figs. 5490-1, and figs 5507-5580. "Those forms, parts, constructions, units, measurements or systems which are conducive of sound construction, good practice, and safe operation, but which do not affect either interchangeability of parts or interchangeability of cars as a whole." See *Master Car Builders' Standards*.

light and some of the same, for produc-

- Recording-bell** (street-cars). A bell attached to a bell-punch or other instrument on which the conductor records the fares collected, to indicate that fact to the passengers.
- Reducer** (pipe fittings, which see). Fig. 2942. A means of decreasing the diameter of the pipe used. They are either *bushings*, *couplings* or T's, which see.
- Reducing collar** (for lamps). Fig. 2403; 24, fig. 2388. See *Collar*.
- Reducing pipe-coupling**. Figs 2942, etc. See *Reducer*.
- Reducing tee** or T (pipe-fittings, which see). See also *Reducer* and T.
- Reducing-valve** (Westinghouse train signal apparatus). Figs. 2405-6. A valve for reducing the pressure of air admitted to the train signal-pipes below that maintained in the brake-pipes and main reservoir. In the train-signal apparatus a very low pressure, not usually exceeding two atmospheres, is used.
- Reflector**. 1. (Lamps.) 14, figs. 3261-3317. "A polished surface for reflecting light."—*Webster*. *Lamp-chimney Reflector*, 15, figs. 3261-3317.
2. (Lanterns). Figs. 3552-62. *Reflector and chimney-holder combined* (for lamp), fig. 3436.
- Reflectors** (Pintsch system):
- 80 (fig. 3232); for use only on bracket-lamps in postal or express-cars. Enamelled iron, white under surface. Has a sheet iron flue, as shown.
- 110 (fig. 3207); reflector for all center lamps. Enamelled iron, white surface.
- 111 (fig. 3206); cup-reflector for all center lamp. Enamelled iron or solid porcelain. 111A, as desired. In the latter case is known as No. 111A.
- 112 (fig. 3203); reflector for four-flame vestibule-lamp. 195 (fig. 3241) Enamelled iron, white surface.
- 113 (fig. 3204); reflector for two-flame vestibule-lamp. 194 (fig. 3239); Enamelled iron, white surface.
- 114 (fig. 3205); reflector for wall-lamp. 205 (fig. 3247); Enamelled iron, white surface.
- 115 (fig. 3243); reflector for mail-cars. Fits any center lamp. Enamelled iron, white under surface.
- Refrigerator** (of a refrigerator-car). Figs. 274-86. The chamber, constituting the main body of the car, in which the paying load is placed.
- Refrigerator-car**. Figs. 9-14, 274-86. A car for carrying perishable articles, especially meat, constructed with compartments in which ice is carried, and with double floor, sides and roof, to keep the ice from melting. A great variety of types have been designed, but they can all be reduced to four general classes, viz.: Those which use ice and salt, or ice only, for refrigerating, and those which carry ice overhead in *ice-pans* or in the ends of the cars in *ice-racks* or *tubes*. The most important difference of all in refrigerator-cars, the difference in the character of the circulation and dryness of air, is not touched by the classification, nor can it be gone into. The temperature aimed at is about 40° F. or 8° above freezing. Many of the older cars were mere air-tight boxes, without any circulation whatever, with the effect that an unnecessarily low temperature was required in one part of the car to keep all cool enough. The principal difference in the external appearance of refrigerator-cars, as may be seen, is their greater height and width. Refrigerator-cars using salt use from 1 to 2 bushels for each 100 lbs. of ice.
- Of the Refrigerator-cars now in service, the following deserve to be mentioned:
- The Ayer; the Canda, figs. 12, 283-6; the Chase, fig. 14; the Hanrahan, figs. 10, 274-7; the Tiffany; the Wickes, fig. 13.
- Refrigerator-door hinge**. Fig. 2613.
- Refrigerator express-car**. Figs. 168-70, and 596-7. A car that does not differ from a regular baggage and express car, except that about one-third of it is partitioned off, insulated and iced to maintain a low temperature and in which to carry perishable goods.
- Register**. R, figs. 4327-9a. An aperture for the passage of air, provided with suitable valves, doors and sliding or revolving plates, by which the aperture is opened or closed. See *Feed-door register*. *Frieze-ventilator register*. *Ventilating register*.
- Register-face**. A grating with which the opening of a register is covered. It is usually of some ornamental pattern.
- Regulating**. An unusual term for *switching*, or the act of moving cars from one track to another in making up or separating trains. Also called *drilling*, or, in England, *marshaling*, or, less correctly, *shunting*.
- Regulating-nut-spring**, etc. (Pump governor.) 65 and 66, fig. 1716.
- Regulating-valve** (Pintsch gas pressure-regulator). See *Pressure-regulator*.
- Regulator** (Frost-system of gas-lighting). Figs. 3117-3118. Air from the tank enters the *regulator* at the inlet, as indicated by the arrow, and, the *valve* being held away from its valve seat by the action of the *graduating-spring*, 6, upon the *diaphragm*, 7, to which the *valve* is connected, passes between the *valve* and its *seat* into the chamber back of the *diaphragm* and thence through the *roof-pipe* to the *carburetors*. As the pressure in the *carburetors* rises, it sets back into the chamber of the *regulator*, and, acting against the *diaphragm*, overcomes the resistance of the *graduating spring*, 6, and displaces the *diaphragm* from its normal position. The *diaphragm* thus displaced carries the *valve* toward its seat, and in this manner gradually closes the air port until the pressure in the *carburetors* has reached 1½ lbs. per square inch, at which pressure the *valve* is seated and prevents the further flow of air. As soon as the pressure in the *carburetors* falls below 1½ lbs., the resistance of the *graduating-spring*, being greater than that of the air pressure upon the *diaphragm*, forces the *valve* off from its *seat* and allows sufficient air to pass to keep the pressure up to that for which the *regulator* is adjusted.
- Regulator** (Pintsch system of gas-lighting). 244, fig. 3168. An automatic regulator which receives the gas from the *receiver* at its inlet at any pressure from 1 to 300 lbs. and automatically reduces it to an outlet pressure of ½ oz. It is screwed to a board, having a recess 12¼ in. diameter and ¾ in. deep to receive the upper surface of the regulator, this board being held against the under side of the car floor by straps and suitable lag screws. The regulator is sealed and is guaranteed by the makers for 5 years, if returned intact and seal unbroken.
- Regulator**. See *Heat and draft-regulator*. Fig. 2867. *Pressure-regulator*.
- Regulator-straps** (Pintsch system). 243, fig. 3227-a. An iron strap used to secure the *regulator* to under side of car. One is passed across each end of the board carrying the *regulator*, and is lag-screwed to the board and to the car sills.
- Release-cock** (Westinghouse brake). Fig. 326; 18, figs. 1693-8, and figs. 1733. More properly an *auxiliary reservoir bleeding-valve*. A cock attached to the *auxiliary-reservoir* for permitting the compressed air to escape therefrom, when the locomotive is detached or when the apparatus is out of order, so as to release or "bleed" the brakes.
- Release-spring**. 1. (Passenger-car trucks.) 91, figs. 4806-4966. A spring attached to the *end-piece* of a truck for the purpose of throwing the brakes out of contact with the wheels. The name is also applied to any spring used to throw the brakes off from the wheels.
2. (Westinghouse brake.) 12, fig. 1727. A spiral spring which acts so as to move the brake-piston inward and thus release the brakes from the wheels after the compressed air is allowed to escape from the cylinders. It was formerly carried outside the brake-cylinder by a *release-spring bracket*, etc., but is now placed inside the cylinder.
- Reservoir**. 1. (Air-brake apparatus.) The *main reservoir*, figs. 1732, 1690 and 1, figs. 1699-1707, goes under the locomotive, and the *auxiliary reservoir*, figs. 1734-6, under the tender and each car. In the latest and most approved designs the driver brake also is operated from

a separate triple-valve and auxiliary reservoir is combined with the triple-valve and brake-cylinder placed on the engine. In the Westinghouse freight-brake, figs. 1728-9, the auxiliary reservoir is connected with the brake-cylinder and triple-valve.

2. See *Lamp-reservoir*, or *lamp-fount*.

3. (Pintsch gas-lighting apparatus.) See *Receiver*.

4. (Student lamp.) **6**, figs. 3399. The removable cylinder carried within the shell called the *outside-cylinder*.

Reservoir drain-cock (Westinghouse brake). **18**, figs. 1693-8 and 1733. A cock for emptying the reservoir of any water condensed from the air. Also used as a *release-cock*, or *cylinder release-cock*, which see, for letting off or "bleeding" the brake.

Reservoir drip-chamber (student lamp). **C**, fig. 3399. A cavity in the outside cylinder below the reservoir. Used only in the best lamps.

Reservoir pipe (for Westinghouse brake). **8**, figs. 1699-1707. Also called *air-pipe* and *discharge-pipe*. The pipe conveying the air from the air-pump to the reservoir.

Reservoir-union. Fig. 1721. See *Union*.

Rest. That which supports something or on which it rests.

See *Arm-rest*.
Berth-rest.
Foot-rest.
Grate-rest.
Side foot-rest.

Side-rest (tip-car).
Stake-rest.
Upper berth-rest.
Window-blind rest.
Window-sash rest (street cars).

Restaurant car. Fig. 104. A *cofe* or *lunch car*.

Retaining-ring (for wheel tires). Figs. 5255-68, 5374-81, 5292-99, 5323, 5337-47. A ring securing the tire to the wheel. See *Mansell retaining-ring*, and *tire-fastening*.

Return-bend (pipe-fittings). Figs. 2945-6. A short cast-iron U-shaped tube for uniting the ends of two wrought-iron pipes. They are called *close return-bends*, or *open return-bends*, according as the section of the pipe is kept a distinct circle at all points. The close return-bend has simply a partition dividing the two parts for a short distance.

Return heating system (one of the Safety's heating systems). Figs. 3028-30. In this arrangement of the *Standard system*, the method of application of jackets to the circulation piping is not materially changed, but, by means of a second drain pipe, the condensed steam, after performing its work, is returned to the locomotive instead of being discharged to the ground.

Special valves on the car, and a suction pump on the tender, are necessary adjuncts of this system. By means of the pump, a vacuum of 15 to 22 inches is constantly maintained on the second or return train pipe. The returned condensation being at a high temperature when reaching the tender tank, a saving of fuel is thereby effected. Lower steam pressures can be used with this system than with the others, the exhaust of the suction pump alone is sometimes sufficient to keep up the circulation.

Return tag. Fig. 3884. A tag attached to cars, usually by slipping it on to the shackle of the seal, and used as an evidence of the due arrival of the car or as a direction to what point the car itself is to be returned.

Reversible car-seat. Fig. 3993. A name sometimes applied to the common form of car-seat in which the back only reverses, but more properly applied to such a seat as the *Buntin reversible car-seat*, which see, in which the seat is moved and not the seat-back only, what was the seat becoming the seat-back, and *vice versa*.

Reversing-cylinder (Westinghouse 8-in. air-pump). **22**, fig. 1689. A small hollow metal cylinder in the steam

metal screw-plug screwed into the recess which receives the reversing-cylinder and holds the latter in its place.

Reversing-piston (8-in. air-pump). **23**, fig. 1689. A small piston placed above the steam-valves and which moves the latter downward. The excess of steam-pressure on the under side of the upper steam-valve, owing to its being larger than the lower one, moves them upward when the pressure on the reversing-piston is released by the movement of the *reversing-valve*, at the top of the stroke of the main steam-piston, which then strikes the *reversing-valve stem*, which see.

Reversing-piston packing-ring (8-in. air-pump). **24**, fig. 1689. See *Piston*.

Reversing-valve (8-in. air-pump). **16**, fig. 1689. A slide-valve working in a small cylinder in the steam-cylinder head, and thus controlling the admission and exhaust of steam to and from the *reversing-piston*. See *Reversing-valve stem*.

Reversing valve-bush, or bushing (Westinghouse 8-in. air-pump). **19**, fig. 1689. See *Bushing*.

Reversing-valve cap, or chamber-cap (Westinghouse 8-in. air-pump). **20**, fig. 1689. A screw-plug which holds the *reversing-valve bushing* in its place.

Reversing-valve plate (Westinghouse 8-in. air-pump). **18**, fig. 1689.

Reversing-valve stem (Westinghouse 8-in. air-pump). **17**, fig. 1689. A rod attached at the upper end to the reversing-valve. It extends downward into a hole bored into the piston-rod, and is moved by the piston at each end of its stroke. The admission and exhaust of steam above the reversing piston is changed at each end of the stroke of the main steam-piston, and by this means the main-valves are shifted and made to admit steam, alternately, above and below the steam-piston.

Revolving-chair. Figs. 3926-7, 3989-92, 3996-9, 4109. See *Parlor-car chair*. *Hartley chair*.

Rib (of a cast-iron wheel). A *bracket*. See *Wheel-rib*. *Car-wheel*.

Ridge. See *Roof-ridge*.

Ridge-clamp. Figs. 2355-67. The grooved stick on top of the boarding of a pitched roof directly over the ridge-pole. In the Winslow car-roof they are called simply *roof strips*, which see.

Ridge-pole. **84**, figs. 229-66, etc. A longitudinal timber in the center of a roof, supported by the carlines or rafters on which the roof-boards rest. In some cases the rafters are framed into the ridge-pole, and in some cases, as figs. 2370-4, the ridge-pole is grooved to receive the roof-sheets.

Ridge-timber. **110**, figs. 332-5. A timber which caps the intersection of two inclined floors meeting in the center of the car as in side-dump or ore-cars. If the inclined floors were the two sides of a gable-roof the *ridge-timber* would then become a *ridge-pole*.

Right and left of a seat is as for a person sitting in a seat; *of a stove or of the end of a car* is as for a person facing it; *of a brace* is one which leans to the right or left of a person standing facing the side of the car.

Right and left screw. A pair of screw-threads cut turning in opposite directions, so that a common nut or pipe-coupling tapped with similar threads will, according to the direction in which it is turned, draw the two rods nearer together or press them farther apart.

Right-and-left-screw turnbuckles. Figs. 3726, 3727a. See *Turnbuckle*. Other forms are *swivel turnbuckle*, fig. 3725, and *tube turnbuckle*, fig. 3727.

Right-hand brace-pocket. See *Right and left* and *Left-hand brace-pocket*.

Right-hand seat (of car-seats with a stationary back). See *Right and left*.

Right-hand seat-end. See above.

Rigid-bolster truck. Figs. 4576-4739, etc. A car-truck with a bolster which has no lateral or *swing motion*, which see. See also *Bolster* and *truck-bolster*.

Rigid caster (for tables). Fig. 4114. See *Caster*. A "rigid caster" is a mere socket and not properly a caster at all, except from being used in the same manner as a finish for legs of tables and chairs.

Rim. 1. (Of a car-wheel.) That portion of a car-wheel outside of the *plate*. The *face* of the rim is the outside vertical edge or face.

2. (Of a wrought-iron wheel.) The wrought-iron ring which is welded to the outer ends of the spokes and surrounded by the tire.

Rim-latch. Figs. 2558-9, 2570, 2731-3. A latch which is attached to the outside of a door and is not let into it.

Rim-lock. Figs. 2653-2703, etc. "A lock having an exterior metallic case which projects from the face of the door, differing thus from a mortise-lock."—*Knight*.

Ring. 1. See

<i>Ash-pit ring.</i>	<i>Packing-ring.</i>
<i>Casing-ring.</i>	<i>Pull-ring.</i>
<i>Grate-ring.</i>	<i>Rubber-packing ring.</i>
<i>Helper-ring.</i>	<i>Slewing-ring.</i>
<i>Inside-ring.</i>	<i>Stove-pipe ring.</i>
<i>Lamp-ring.</i>	<i>Top-ring.</i>
<i>Mansell retaining-ring.</i>	<i>Ventilator-ring.</i>
<i>Man-hole ring.</i>	<i>Window-curtain ring.</i>

2. (Baker-heater). Figs. 2869, 2893e, 2929b. A cast-iron ring attached to the *smoke-top* to stiffen it and hold the feed-door. Also an *ash-pit* ring.

Riser. 3, figs. 3525-7. A piece of marble or metal set on edge around about the wash-bowls to prevent water from running against the walls. See *Step-riser*. *Seat-riser*.

Rising-timber. 110, fig. 328-31. A timber placed upon another parallel or transverse timber to get greater height.

Rivet. "A pin of iron or other metal with a head drawn through a piece of timber or metal, and the point bent or spread and beat down fast to prevent it being drawn out, or a pin or bolt clinched at both ends."—*Webster*. See *Coupling-link rivet*. The *seat-arm pivot*, which see, figs. 4034-9, is usually in the trade termed a rivet, but incorrectly.

Rivet-fastening (English). Fig. 5344. As applied to railroad wheels, the oldest and most defective mode of securing the tire to the wheel. Little used. See *Tire-fastening*.

Rivet-seal. Figs. 3879. A seal with a lead rivet which is closed by a die. See *Car-seal*.

Roadmasters' hand-car. Figs. 5586-7.

Roberts, Throp & Company hand and velocipede cars. Figs. 5583-4, 5589-90.

Roberts' woven-wire car-seats and fabrics. Figs. 3952-67.

Robinson radial-truck (street-cars). Figs. 5671-3. A truck, so-called, which consists of three pairs of wheels, each pair carrying a frame. One pair of wheels is placed under each end of the car, and the third pair of wheels with the frame is in the middle of the car. The three truck-frames or so joined together that when on a curve the middle pair of wheels rotates the end-trucks about their center-pins and tend to keep the axles perpendicular to the track, as shown in the figures.

Rocker (tip-car). A crescent-shaped casting bolted to the *rocker-timbers* of the car-body on which the body rests and rolls when the body is tipped.

Rocker-bearing (tip-car). The iron-cap for the rocker-bearing *timber* to support the rocker.

Rocker-bearing timber (tip-car). A horizontal timber at the end of the car on which the *rocker-bearing* rests.

Rocker-bearing-timber hangers (tip-car). Vertical timbers or iron bars framed and bolted to the *end-piece*, to which the rocker-bearing timbers are fastened.

Rocker car-seat. Figs. 3917-20, 3922, 3970-1, 3982, etc. A seat having the bottom adjustable so as to give it an inclination towards the seat back in all cases, on which,

ever side the seat-back may be placed. All modern car-seats have mechanism by which this inclination is automatically given to the seat when the back is reversed or swung back. See *Rocker* and *car-seat*.

Rocker-casting. ("H. & K." reclining and "walk-over" seat.) Figs. 64-5. A casting forming a part of the cushion carrier or stand, which is moved back and forth by the *seat-back arms* and moves the cushion forward, as well as giving it some inclination toward the back.

Rocker side-bearing. See *Side-bearing*.

Rocker-timbers (tip-car). See *Rocker*.

Rocking-bar (heaters). Fig. 3067. A horizontal bar which supports the grate, and on which the latter is attached by a pivot in the center so that it can be turned horizontally and thus shake down the ashes.

Rocking-lever. J, fig. 324a. A hell-crank which operates the toggle-joint, to open and close *King's-door* for hopper-bottom cars.

Rock-plank. A *truss-plank*, which see.

Rock-shaft arm (Hartley chair, which see). 8, figs. 3998-9.

Rod. In car building this term generally means a slender bar of iron *with a nut on each end*, in distinction from a *bolt* which has a head on one end and a nut on the other. Very long bolts, however, are often called rods. Rods in general take their name from the parts with which they are connected or the use which they serve. Among the rods used in car framing are:

<i>Body-bolster truss-rod.</i>	<i>Draw-rod.</i>
<i>Body brace-rod (center and end).</i>	<i>End-girth tie-rod.</i>
<i>Body counterbrace-rod.</i>	<i>Girth tie-rod.</i>
<i>Body truss-rod.</i>	<i>Inverted body-truss-rod.</i>
<i>Brace straining-rod.</i>	<i>Overhang brace-rod.</i>
<i>Center draw-rod.</i>	<i>Plate-rod.</i>
<i>Cross-frame, or Needle-beam truss-rod.</i>	<i>Platform tie-rod.</i>
	<i>Platform truss-rod.</i>
	<i>Sill-and-plate rod.</i>
	<i>Sill tie-rod.</i>

Among the rods connected with brake-gear are:

<i>Brake-beam truss-rod.</i>	<i>Floating connecting-rod.</i>
<i>Brake-block tie-rod.</i>	<i>Long brake-rod.</i>
<i>Brake-shaft connecting-rod.</i>	<i>Lower brake-rod.</i>
<i>Cylinder-lever tie-rod.</i>	<i>Release-lever rod.</i>
	<i>Secondary brake-rod.</i>

Among the rods in trucks are:

<i>Pedestal stay-rod.</i>	<i>Truck-bolster truss-rod.</i>
<i>Safety-beam tie-rod.</i>	<i>Wheel-piece tie-rod.</i>
<i>Safety-beam truss-rod.</i>	<i>Wheel-piece truss-rod.</i>
<i>Transom truss-rod.</i>	

Among rods for interior fittings of cars are:

<i>Basket-rack rod.</i>	<i>Window-curtain rod.</i>
<i>Berth-curtain rod.</i>	<i>Window-shade rod.</i>
<i>Grain-door rod.</i>	

See also

<i>Candle-rod.</i>	<i>Piston-rod.</i>
<i>Hand-car truss-rod.</i>	<i>Tank-valve rod, etc.</i>
<i>Lever-frame truss-rod.</i>	

Rodgers ballast-car and distributing plow. Figs. 213-4.

A hopper-bottom car with bottom-doors by which crushed stone or gravel ballast can be distributed between the rails, and a flat-car with a plow attached beneath it, by which the ballast is levelled and plowed out over the ends of the ties and cleaned from the rails.

Rod-hanger (bell-cord). Figs. 2519-23, etc. See *Bell-cord hanger*.

Roe-ventilator. Fig. 4309. See *Ventilators*.

Roll (of upholstery). Figs. 3942. See *Felt-edge*.

Rolled-axle. An axle made of rolled iron. See *Axle*. *Car-axle*.

Roller. 1. "That which rolls; that which turns on its own axis, particularly a cylinder of wood, stone, metal, etc."—*Webster*.

See <i>Adjustable roller car-seat.</i>	<i>Side-bearing roller.</i>
<i>Friction-roller.</i>	<i>Sliding-door friction-roller.</i>

2. (Window-shades.) Fig. 4565. The cylinder on which the shade is rolled up, containing within it the springs which actuate it. See *Hartshorn and McKay shade-roller*.

3. (Of pile-driver car.) 19, figs. 404-1. The small wheels under the *swinging-platform* rolling upon the track attached to the floor of the car.

Roller-bearings. Figs. 5680-83. 1. Journal bearings in which the load is carried upon small cylindrical rollers inserted between the shaft or axle journal and the bushing or box which surrounds it. These cylinders roll between the journal and the box bearing, thus substituting rolling friction for rubbing friction.

There are numerous types, but the ones in most favor to-day are the *Meneely* and *Hjatt* (which see). The *Meneely* bearings have been in use for some years on steam roads under passenger-cars, and have given good satisfaction to the roads using them. Their use on steam roads is very limited, being confined to two roads; and to only a few cars. The sentiment prevailing seems to be that the saving effected on steam roads where stops are infrequent, does not warrant their adoption. In starting a single car the difference in initial horse-power required is, however, very great, and *roller-bearings* are in considerable favor on street and suburban cars making very frequent stops and starts. This field is promising for their general adoption.

2. For window shades. See *Hartshorn and McKay shade roller*. Figs. 4567-75.

Roller side-bearing. Fig. 4747. A side-bearing, with one or more rollers on which the car-body rests. See *Side-bearing*.

Roller-side bearing truck. Figs. 4747-50. A lateral motion diamond truck whose frame is very like a *swing-motion truck* (figs. 4740-6), with a rigid *spring plank*. Lateral motion is given to the truck bolster by placing it upon cylindrical rollers resting upon the spring-caps. The spring-cap and bolster bearing plate are concaved, so that the motion of the rollers is restrained and the truck bolster given stability. The rollers and their bearings are shown in figs. 4748-9.

Roller-thimble (Gould vestibule). 44, figs. 2431-6. The top of the *Front face-plate gravity-bar*, which is rounded to carry a roller wheel, to reduce the friction between the bar and *front face-plate*.

Roof. Figs. 2355-97. "The cover or upper part of a house or other building, consisting of rafters covered with boards, shingles, or tiles, with a side or sides sloping from the ridge for the purpose of carrying off the water that falls in rain or snow."—*Webster*. The roof of passenger-cars is in two parts, commonly called the *upper* and *lower deck*, which see. See *Car-roof*.

Also <i>Arched-roof.</i>	<i>Platform-roof.</i>
"A" <i>car-roof.</i>	<i>Pitching-roof.</i>
<i>Asphalt-roof.</i>	<i>Single board-roof.</i>
<i>Corrugated metal car-roof.</i>	<i>Winslow-roof.</i>
<i>Double-board roof.</i>	"X" <i>roof.</i>

Roof-apron. 106, fig. 435-73, etc. A vertical or inclined metal or wooden screen attached to the end of a passenger-car roof to prevent cinders, rain, or snow from being driven on to the platform and into the doorway.

Roof ascending-rail (English). 176, figs. 501-4. See *Ascending-rail*. *Roof-binder*, fig. 633.

Roof-boards. 1. 83, figs. 229-66. The boards which form a covering of a roof. They run longitudinally on passenger cars and usually transversely on freight-cars. See *Car-roof*.

2. (English.) 131, figs. 501-4. The planking forming the roof. It invariably runs longitudinally.

Roof brace (of a center lamp or chandelier). Figs. 3270, the lamp to the

Roof commode-handle (English). 176, figs. 501-4. See *Ascending rail*.

Roof corner-casting (passenger-cars). A cast-iron molding for the corners of platform-roofs. They are made rights and lefts, and are specified as for a person standing and facing the end of the car.

Roof cover-strip (single-board roofs). A metallic U-shaped strip used to cover the joints of the roof-sheets. See *Roof-strip*.

Roof grab-iron (box and stock cars). 60, fig. 229, etc. A *hand-hold*. An iron bar fastened to the roof to be grasped when ascending the ladder at the end of the car. Also called *ladder-handle*. See *Grab-iron*.

Roof hand-rail. 190, fig. 229, etc.; figs. 878-9, 5546-7. A hand-rail usually made of gas-pipe in front of the brake-wheel, designed to protect the brakeman when applying the brakes. It is stiffened by a *hand-rail brace*. The whole arrangement shown in these figures is designed to take the place of the *brake-step*, which has been disapproved of by vote of the M. C. B. Association. See *Brake-step*.

Roofing-canvas. A heavy duck for covering the outside of the roofs of cars, chiefly used on street cars.

In England it is universally used for all cars with roofs. It is bedded on fresh thick white lead or *smudge* (which see), and then receives several coats of the same paint.

Roofing-duck. The trade name for the cloth used for head linings, manufactured in any width up to 12 ft. It is lighter than roofing-canvas.

Roof-lamp (English). 160 to 168, figs. 501-4. A lamp used to illuminate the inside of a carriage or other covered vehicle. A circular hole, about 8 in. diameter, is cut through the roof, and the roof lamp placed in this aperture from the outside, the glass and burner when in position being a little below the inner surface of the roof, and entirely inaccessible from within. This form of lamp is wasteful of oil, yields a dim and uncertain light, is costly to handle and the glass is constantly broken. It is therefore being superseded in Germany and England by Pintsch's, Pope's, and similar methods of using compressed oil-gas.

See <i>Lamp-case.</i>	<i>Lamp-burner.</i>
<i>Lamp-cover.</i>	<i>Lamp-glass.</i>
<i>Lamp-plug.</i>	<i>Lamp-case base.</i>
<i>Lamp-plug stand.</i>	<i>Inner lamp-ring.</i>
<i>Lamp-cover spring-catch.</i>	

Roof-landing. 150, figs. 5654-6. A small platform built on the roof of a trolley-car on which inspectors step in climbing upon the roof to inspect the trolley. In freight-cars it is called a *roof step*.

Roof-light. A *deck-sash*, which see. See also *End roof-light* (street-cars).

Roof-panel (end). The panel over the door of passenger-cars.

Roof-ridge (freight-cars). The intersection of the two plane surfaces forming a pitching-roof.

Roof running-board. 87, figs. 229-66, etc. See *Running-board*.

Roof running-board bracket. 89, figs. 229-66, etc. See *Running-board bracket*.

Roof running-board extension. 88, figs. 229-66, etc. See *Running-board extension*.

Roof-sheets. Figs. 2355-97. Metallic sheets, sometimes corrugated and sometimes not, for covering freight-car roofs. Their joints are sometimes closed by a *roof cover-strip*, and sometimes the edges fit into grooves in wooden carlines or *joint-strips*. See *Car-roof*.

Roof-step (freight-car roofs). A horizontal board which extends sidewise from the running-board to near the side of the car above the ladder, its object being to give a secure foothold and protect the roof from wear. It is not much in use.

Roof-stick, or hoop-stick (English). 120, fig. 501. American equipment, *carline*. A piece of timber which

supports the planking of the roof, and is either bent or cut to the curve of the roof.

Roof-strap (street-cars). See *Diagonal roof-strap*.

Roof-strips. 1. Used quite frequently, but somewhat confusingly to designate a *purlin*, which see.

2. (Passenger-cars.) Narrow wooden strips attached as stiffeners to the under side of the carlines of the lower deck.

3. (Winslow and other car-roofs.) Figs. 2355-94. A longitudinal wooden strip on top of the metal roof-sheets to which the roof-boards are attached. The central roof-strip is called in other roofs a *ridge-clamp*. Sometimes at the ridge a single *ridge-clamp* is used.

Roof-ventilator. See *Ventilator*.

Rope. "A large string or line composed of several strands twisted together."—*Webster*. See *Berth safety-rope*. *Berth-spring rope*.

Roping-staple. 58, figs. 229-66. A U-bolt secured to the side-sill near the end of a car into which the hook of a switching rope may be caught, so that a switching locomotive may pull cars on side tracks while it is on the main track, or *vice-versa*.

Rose. Figs. 2640-1, 2671. See *Door-latch rose*. Sometimes called a *rosette*.

Ross flange brake-shoe. Figs. 1644-5, 1655, 1660. A brake-shoe with a hollow in the middle where most of the rolling wear comes upon the wheel, and with a lip projecting over the flange of the wheel. The brake-shoe is held in position laterally by the outside and inside *flange-lips*. The two side portions having a bearing upon the wheel are termed the flange and tread *bearing-blocks*. The shoe rests on the flange and on the outside of the tread of the wheel, as shown in the figures, the throat of the shoe being entirely open. This shoe keeps the flange and the outside of the tire worn down so that the driving-wheels or car-wheels do not have to be turned down so frequently as they would with ordinary shoes. It is used largely on steel-tired car-wheels. This shoe is in great favor, especially the combination Ross-Meehan shoe, which see. Figs. 1646-54.

Ross-Meehan brake-shoe. Figs. 1646-7, 1649-52. A combination of both the Ross and Meehan patents, using the Ross shape and the steel slugs of the *Meehan brake-shoe*, making a shoe that not only bears on the proper part of the wheel-tire, but also gives a shoe that will outlast several sets of ordinary cast-iron brake-shoes.

At the present time there are made about 450 tons of the Ross-Meehan shoes per month. Another important advantage is the additional mileage that is obtained from a tire before it has to be turned down, over the ordinary iron brake-shoe.

Rotary snow-shovel. Fig. 238. See *Snow-shovel*.

Rotary-valve (engineer's valve, etc.). 43, figs. 1710-15.

Rotary valve-key (engineer's valve, etc.). 41, figs. 1710-15.

Rotary valve-seat (engineer's valve, etc.). 33, figs. 1710-15.

Rough-stuff, or scraping filling-coat (painting). The next coat after the *priming*, which see. Its purpose is not to protect, but to level the surface of the wood. Therefore, none of it is left on the higher portions of the surface, but used merely to fill the hollows to a level with these. The surface is scraped to an even plane-level with the highest level of the bare wood. After 24 hours to dry, a second coat is put on, scraped down to the level of the highest portions of the bare wood. After a second 24 hours to dry, the car is sand-papered or rubbed down, pumice-stoned, and is ready for the *color-coats*, which see. See also *Painting*. A common material for this coat is 6 lbs. keg white lead, 7 lbs. whiting, mixed thick with coat-japan and ground in a paint-mill. This mixture is thinned with turpentine, so as to be thin enough

to work easily, and so thick as not to run. It is put on with a leveler or scraper, often made of an old saw-blade.

Round-bar spiral-spring. Figs. 5192-5228. A spiral spring made of one or more round bars of metal. See *Spiral-spring*. This form is the most common of all and the most efficient in theory for a given weight of metal,

Round-cornered car. A method of finishing the ends of passenger-cars by omitting the corner-posts and rounding them off to a very large radius. It is exceptional and quite out of use.

Round (of a ladder). 59, figs. 229, etc. The horizontal bars on which the foot rests. They are called rounds, whether of wood or iron, and whether round or square. See *Ladder-rounds*.

Round seat-stop. Figs. 4065-8. See *Seat-stop*.

Rubber gasket. See *Gasket*.

Rubber floor-mat. Figs. 2856-7. There are two leading styles, *corrugated rubber* and *perforated rubber*.

Rubber spring. A car-spring made of india-rubber. They are rarely used, it having been found difficult to secure uniform quality, and the cost of a really good quality being higher than steel spiral-springs of equal efficiency and durability. The same is true of the various rubber and steel compound springs. Rubber springs are in occasional use on platform safety chains for passenger equipment, figs. 5538-9, and in England they are used for draft and buffing.

Rubber-tread (for step). An india-rubber covering fastened to a step or *threshold-plate*, of a car to prevent persons from slipping when ascending or descending the steps.

Rules for Interchange. See *Interchange of Traffic*.

Runners (foundry). Apertures which connect the *ingate* of a mold for casting metals with spaces to be filled with molten metal.

Running-board. 1. 87, figs. 229-66, etc., and figs. 682, 895-6. A plane surface, made usually of boards, for train men to walk or run on. It is placed on the roof of box or stock cars and at the side of tank cars. Gondola and flat cars usually have none, but hopper-bottom cars sometimes have a running-board passing over the tops of the end-rails and drop-door beam. In 1888 the M. C. B. Association recommended "that the ends of the running-boards of box-cars be made to project over the ends of the cars, so that the minimum distance between the ends of those on adjoining cars will not be over 12 inches; and that the running boards be made not less than two feet wide, and made of three boards 7 by 1 inch. The projecting ends to be supported on two brackets, at each end of the car, made of $\frac{3}{4}$ by $1\frac{1}{2}$ inch iron, with a hard wood cleat 3 by 1 inch on upper ends, fastened with one $\frac{1}{2}$ inch bolt and nut in each bracket. The lower end of each bracket to be fastened to the end of the car with two $\frac{1}{2}$ inch bolts and nuts."

In 1893, pursuant to a recommendation of the Committee, this standard was revised with the idea of eliminating the dimension of detail parts and confining the recommendations of practice to a few general suggestions. The recommendation of the committee were followed and the following adopted as Recommended Practice, viz.: that "the ends of the running-boards of box cars be made to project over the ends of the cars, and be properly supported, so that the minimum distance between the ends of those on adjoining cars shall not be over 12 inches, and that the running-boards be made not less than two feet wide. See Proceedings, 1888, pages 24 and 123, and Proceedings, 1893.

Figs. 5546-7 shows the running-boards as recommended in 1888, and it conforms to the Recommended Practice of 1893.

2. (Tank-car.) 119, figs. 374-6. The only substitute for a car-floor.

Running board-blocking. 86a, figs. 278-86. Rectangular-shaped blocks, the acute angle of which is the same as the slope of the car-roof. Inserted under the running boards to level them up and to give them a bearing on the roof boards over the carlines.

Running-board bracket. 1. Figs. 895-6; 89, figs. 229-66, etc. See above.

2. (Tank-car.) Cast-iron knees attached to the main-sills of a tank car, and projecting outward to support the running-board.

Running-board extension. 88, figs. 229-66, etc. The part which extends beyond the end of the car-body so as to bring the ends of the running-boards on adjoining cars nearer together to facilitate the passage of trainmen from one car to another. See *Running-board*.

Russell snow-plows. Figs. 222-5, 408-9. A type of push plow built by the Ensign Manufacturing Company, whose special features are the heavy and compact framing, figs. 408-9; the use of a power-bar by which the push of the locomotive is transmitted to the forward end of the plow; and the use of an extra heavy truck, fig. 4579, with truck frames and journals inside the wheels as well as on the outside. The wing elevator plow, figs. 222, 225, has adjustable wings or projections on each side with inclined planes, operated from the interior of the plow to carry or throw the snow out of the cut, and to increase its width.

Russia iron. A form of sheet iron manufactured in Russia the exact process for making which has heretofore been kept secret, but which consists essentially in forming a chemical compound of iron upon its surface at the same time that it is highly polished, so that it is not likely to rust. Modern substitutes for this iron are also known as *planished iron*, which see.

S

Saddle. "A seat or pad to be placed on the back of an animal to support the rider or the load."—*Knight*. Hence, a block or plate which acts as a bearing or support for a rod, beam, etc., in construction, is called a saddle. See *Body truss-rod saddle*. *Spring-saddle*. *Truss-rod saddle*. *Bolster truss-rod saddle*.

Safety-beam (passenger-car trucks). 51, figs. 4842-4966. A longitudinal timber connecting the *end-piece* and *transom* above the axles and inside of each *wheel-piece*. Iron straps (*axle safety-bearings*) are attached to the beam and pass under the axles so as to hold them in position in case of a breakage of axles or wheels on either side. An additional *middle safety-beam* is used on six-wheel trucks, 52, fig. 4957-66.

Safety-beam block. 53, figs. 4842-4966. A block fastened to the under side of a safety-beam and to which a *safety-strap* is attached. It is put there to bring the safety-beam nearer to the axle, and is usually cut out so as to conform to the shape of the latter. In some trucks a sort of a queen-post truss is used as in fig. 4813.

Safety-beam iron. 60, figs. 4957-66. A wrought-iron bar or casting bolted to the transom (six-wheeled truck), by which the *middle safety-beam* is attached to the transoms.

Safety-beam tie-rod. 59, figs. 4942-66. A longitudinal rod alongside a safety-beam, tying the *end-piece* and *transom* together. A *safety-beam truss-rod* sometimes serves as a substitute and equivalent.

Safety-beam truss-rod. A long longitudinal rod parallel with a safety-beam, extending from one end-piece truck to the other, under the transoms, so as to support them, in addition to serving as a substitute for *safety-beam tie-rods*, which see. Not much in use to-day.

Safety-beam truss-rod bearings. Cast or wrought iron pieces attached to the transoms. See above. Not much

Safety-bearing thimbles. Fig. 4813. See *Axle safety-bearing thimbles*.

Safety berth-latch. A device by which it is made impossible for the berth to shut itself automatically in case of accidental overturning of the cars. These devices enable the *berth safety-rope*, which see, 26, figs. 2409-12, to be dispensed with. Several deaths have been caused by the upper berth closing up and locking a passenger within it in cases of overturning for lack of one or the other of these devices.

Safety Car-Heating and Lighting Co.'s (systems of steam-heating). Figs. 3023-55. (Standard systems.) The fundamental principle of these systems is the replacing of the heat of the Baker-Heater fire, by the heat of steam from the engine, applied by means of jackets on portions of the circulation piping, but in all cases leaving the Baker-Heater system in such condition that a fire or steam can be used, separately, or in conjunction, without its being necessary to alter or adjust any valves or other devices whatsoever. These systems are all *closed circulation*, the seal of the Baker-Heater being unbroken, and, therefore, no reduction of the water in the pipes, and danger of burning out of the coil. Salt water may be used and is recommended.

Details of the various applications to single and double circulation are given in figs. 3023, 3027, 3029, etc. The water circulation being heated at from three to six different points (instead of one point, as when fire is used in the Baker-Heater) it produces more rapid and more equable heating of the car. See *Coil-jacket system* and *Return-heating system*.

Safety-chain. 1. See *Brake safety-chain* (for brake-beams), 9, figs. 1528-9. *Safety coupling-chain* (for draw-gear), figs. 5538-9 and 5552-5.

2. (English.) 46, figs. 501-4. American equivalent *safety coupling-chain*. An additional coupling-chain provided at one end with a hook, and intended to hold the train together should the main coupling part. Two are secured at each end of the vehicle, one on each side of the main-coupling. Also called *side-chain*.

Safe y-chains, platform (M. C. B. Recommended Practice). Fig. 5539.

Safety-chains, freight-car (M. C. B. Recommended Practice, as to location of). Figs. 5552-5.

Safety-chain eye-bolt, or strap-bolt. 10, figs. 1528-9. See *Brake safety-chain eye-bolt*.

Safety coupling-chain (passenger-car platforms). 55, figs. 2435-45; figs. 5538-9. A chain attached to the platform end-timber and hooked to an eye in the platform of an adjoining car or tender so as to prevent the train from being separated in case the coupling should be detached. They are necessarily used in pairs, an eye and a chain with hook being attached to opposite sides of the same platform.

In 1893 a Recommended Practice was adopted for location and details of platform safety-chains for passenger-cars, as shown in figs. 5538-9.

In 1894 a Recommended Practice was adopted for safety-chains for freight-cars when such chains are used, which is shown in figs. 5552-5. The use of safety-chains on freight cars was not recommended, but when they are used on cars for special service their location is recommended as shown in figs. 5552-5.

Safety's direct steam system (The Safety's Regulating System, L. 188). Figs. 3031-4. By this system it is sought to control the temperature of car by variations of the *radiating surface*. The regulating cock, 775, is capable of adjustment so as to admit steam to one or both radiating pipes on either side of the car, thereby permitting the use of one to four pipes as radiators, according to the requirements of the weather. The condensation is discharged from each radiator pipe separately, through a slotted *angle drip-valve*, 603B. The slot prevents the valve ever being entirely shut off, and

is of sufficient area to drain the pipes, if steam is shut off and the trainmen neglect opening the drip-valve.

Direct steam system, L. 111. Fig. 3035-36:

This is simpler than the Regulating System, and depends for its efficiency upon the close regulation of steam supply possible with the special inlet valve, 603A. This valve has a Jenkins Seat, and is so constructed that the first full turn of the handwheel only opens the valve enough to give $\frac{1}{16}$ sq. in. area of the inlet port. It can be adjusted by the wheel so as to give any desired inlet area from that point to the full area of 1 inch pipe. By this means the flow of steam to the radiator pipes (and therefore the car temperature) can be closely regulated.

Safety-gate. See *Platform-gate*.

Safety-guard (for spring-plank). An iron strap attached to the truck transoms and passing under the spring-plank to hold up the latter in case of accidental breaking of the link-hangers. More properly *spring-plank safety-strap*, which see.

Safety-hanger. See above, also *Brake safety-chain Brake safety-strap. Safety-hanger* (for lower brake-rod).

Safety-hanger (for lower brake-rod). A metal loop or eye attached to a truck and through which the lower brake-rod passes. It is intended to prevent the brake-rod from falling on the track in case it or its connections should break. See note to fig. 1967.

Safety-hanger clip. Figs. 1616g, 1628-9. (National hollow brake-beam.)

Safety-latches. See *Safety berth-latch*.

Safety-plate. (Baker fire-proof heaters.) Figs. 2883, 2899.

An iron plate which covers the hole in the partition between the fire-pot and base of smoke-flue, marked 12, fig. 2866. Its office is to prevent the ignited coals from falling out if the heater be overturned. It is operated by a *safety-plate handle*, figs. 2883, 2899, the safety-plate sliding between *safety-plate guides*, fig. 2896. The *safety-plate* is held closed by a *safety-plate spring*, figs. 2884, 2891, bearing upon the *safety-plate handle*, as in figs. 2885 and 2886.

Safety-plate guide. See *Safety-plate*.

Safety-plate handle. See *Safety-plate*.

Safety-plate spring. See *Safety-plate*.

Safety-plate and gas-preventor. (Baker's perfected heater.) Fig. 2917. This is a cover for the fire-pot with an upturned flange, and is fitted to the top, fig. 2912. It has an upturned flange along its hinged axis, which deflects the cool air that enters when the door is opened, and prevents its mixing with the gases which escape from the fire-pot through the holes in the top, fig. 2912. The gases remaining hot pass up through the smoke-flue and do not escape into the car.

Safety-rod. (Postal-cars.) 12, figs. 599-604. A rod suspended from overhead, over the pouch-racks, within easy reach, to serve as a hand-hold or grab-iron in case of derailment, etc. Certain fittings, figs. 3816-18, are used to fasten it to the roof or sides of car; they are the *safety-rod brackets, bushings* and *T-joints*.

Safety-rope (for sleeping-car berths). 26, figs. 2409-12. More properly *berth safety-rope*, which see. See also *Safety berth-latch*.

Safety-strap. See *Axle safety-strap. Brake safety-strap. Spring-plank safety-strap*.

Safety-valve. 1. (Baker heater.) Fig. 2930-1. A valve formed of an India-rubber ball with which an opening on top of the *circulating-drum* is closed. When the pressure in the drum exceeds the elasticity of the rubber ball, the latter permits the steam or hot water to escape, and thus relieve the former. This *safety-valve* is little used now, it having been replaced by a *safety-vent* or *bushing*, fig. 2919a. The latter is simply a cast-iron cap, the top of which is cut out so that if the pressure in the pipes becomes too high, the top will blow out and relieve it. A new cap must be supplied whenever the

pressure exceeds the limit and the head of the *safety-vent* is blown out.

Safety-valve ball (Baker heater). See *Safety-valve*.

Safety-vent or *bushing*. Fig. 2919a. See *Safety-valve*.

Saloon. 1. "A lofty, spacious apartment."—*Worcester*.

2. The main room in a compartment car (rarely used).

3. One of the smaller subdivisions or state-rooms of a sleeping or parlor-car.

4. 130, figs. 439, 448, 488. A retiring room furnished with urinal and closet-hopper, or soil-hopper; and in the more luxurious cars with a water-closet. The saloon is commonly also provided with washing facilities. Other terms are *lavatory, closet, toilet*, etc.

Saloon carriage (English). Answers the same purpose as an *excursion-car*, or American *private-car*. A luxurious vehicle, one or more of which is kept for hire on most English railways, having one or more large compartments, about 15 ft. long, fitted with tables, sofas, etc., and termed *saloon*, is never used in England in the American sense (4) above. See also *Carriage*.

Saloon door-plate, or *notice-plate*. Figs. 2788-2802.

Saloon furnishings. Figs. 3838-76.

Saloon-handle. Figs. 3844-9. See *Urinal-handle*.

Saloon-hopper. Fig. 3855-69. See *Closet-hopper*. Also called *soil-hopper*.

Saloon hopper-ventilator (Bell's, which see). Figs. 3841-2.

Saloon-latch. Fig. 2704-5, 2731-3, etc. A latch for saloon doors, which consists of a spring-bolt, usually with a *stop* on the inside, which locks the bolt fast, or with a separate bolt for fastening the door from the inside. See below.

Saloon-lock. Figs. 2682-96. The same as a saloon-latch, with provision for locking the door from the outside.

Saloon latches without locking facilities are rarely used.

Saloon paper-hook. Figs. 3852-3. See *Paper-hook*.

Saloon-plate. See *Notice-plate*.

Saloon-roof. Fig. 3857. In some of the more modern cars the saloon is entirely roofed over so as to be distinct from the body of the car. Sometimes the partitions are carried up to the roof of the car.

Saloon-seat. 131, figs. 3854-9. The wooden seat over a closet-hopper.

Saloon side-light (Pintsch gas). Fig. 3246-7.

Saloon stop-latch. See *Saloon-latch*.

Saloon ventilating-jack. Figs. 4325, 4300-1. See *Ventilator*.

Sand-blast process. A process of cutting glass by blowing sand upon it with a strong blast of air. The glass is covered with paper or other elastic surface which it is found the sand does not cut at all while rapidly cutting away the glass itself. The process was invented by observing the action of sand blown by the wind upon the rocks in the western plains of the United States and is now largely used in place of *wheel-cutting*.

Sand-box (street-cars). 127, fig. 5655. A box placed under the seats containing grit for sanding the tracks. It is provided with a *spout* and *valve* operated by a *lever, connecting-rod* and *lever-holder*. See fig. 5656.

Sand-plank. 43, figs. 4580-4757. A common name for *spring-plank*.

Sandwich-plates. See *Flitch-plates; body-bolster flitch-plates*, etc.

Sash. The frame of a window or blind in which the glass or slats are set, but commonly used, especially in compound words, as a substitute for *window*, meaning the window and sash complete. The various members used in framing a sash are the same as a *door-frame*, which see.

See *Deck-sash.*

Door-case window-sash.

Door-light (English).

Door-sash.

Lower door-sash.

Mirror-sash.

Swinging-sash.

Upper door-sash.

Ventilator-sash.

Window-blind sash.

Window-sash.

Sash-balance. A spring or weight with or without a cord, so connected to a sash as to counterbalance its

weight, and make it easy to raise or lower. There are numerous devices of the kind, only two of which are illustrated—the *Caldwell* and the *O. K. Gardner*.

Sash bar-lift. Figs. 4518-26. A sash-lift having a projecting bar sufficiently large to be grasped by the entire hand. Chiefly used for heavy double windows, in parlor-cars, etc.

Sash-fastener. A *Sash-lock*, which see.

Sash-holder. See *Sash-lock*. *Spring sash-holder*.

Sash-lift. 21, fig. 2451; figs. 4491-4526. A metal finger-hold attached to the bottom-rail of a window-sash for raising and lowering it. They are sometimes let in *flush* and so called (fig. 4312), but usually attached on the outside. Sometimes, but rarely, the sash-lift is a mere *knob*, fig. 4470, and so called. A *window-blind lift*, figs. 4422-49, which see, is a somewhat similar device. See *Sash bar-lift*. *End door sash-lift*.

Sash-lock. 22, fig. 4465-90. A spring-bolt attached to a window-sash, or (rarely) a window-blind, provided with thumb-lever (sash-lock trigger), to withdraw the bolt with by one hand, while the sash is lifted by the other. Both hands must thus be used. To accomplish this end less awkwardly *Sash-balances*, figs. 4542-3, have been adopted. See also *Deck-sash latch*.

In the common form of sash-lock, fig. 4476-7, the *sash-lock bolt*, 1, is pressed outward by the *sash-lock spring*, 2, and moved inward when desired by the *sash-lock trigger*, 3. The bolt enters into a *sash-lock bushing*, figs. 4407-8, let into the parting-strip or other part of the window-casing. In place of the bushing, *sash-lock stops*, figs. 4455-64, or *sash-lock plates*, fastened upon the outside of the window-casing, or let in flush, are sometimes used, and occasionally a *sash-lock rack*, figs. 4453-4. A *sash-lock lower stop* is often added at the bottom to hold the sash shut and prevent it from being opened from the outside.

"A variety of terms are used to designate this part of a car. In most of the trade catalogues it is called a *sash-lock*, but Webster says the word *lock* is now appropriated to an instrument composed of a spring, wards and a bolt of iron or steel, used to fasten doors, chests and the like. *The bolt is moved by a key.* Knight says a *lock* is 'a device having a bolt moved by a key, and serving to secure a door, lid or other object.' The device used for fastening car-windows is therefore not properly a *lock*, because it has no key. Of the word *latch* Webster says: 'The primary sense of the root is, to catch, to close, stop, or make fast.' Therefore, *window-latch* was the term adopted to designate this device."

Sash-lock, however, seems to continue to be the established and almost universal designation, and there is room for question, as noted under *lock* and *latch*, which see, whether the true distinction between them is not rather that a *latch* has a beveled bolt and a *lock* a square bolt, instead of whether or not a key is used.

Sash-lock bolt. 1, figs. 4476-7 and 4475. See above.

Sash-lock bushing. Figs. 4407-8. See above.

Sash-lock lower stop. See above and *Sash-lock stop*.

Sash-lock plate. Fig. 4450-2. A *sash-lock stop*. See above.

Sash-lock rack. Fig. 4453-4.

Sash-lock spring. 2, fig. 4477. See *Sash-lock*.

Sash-lock stop. Figs. 4450-64. There are two kinds of stops, *upper stops* for holding the window open, and *lower stops* to hold it shut. *Sash-lock bushings, plates, or racks*, are substitutes and equivalents for sash-lock stops. See *Sash-lock*.

Sash-lock trigger. , fig. 4477. See *Sash-lock*.

Sash-opener. Figs. 4376-80, 4330-41. A contrivance, as a lever or rod, for opening a window, used chiefly for the *deck-sashes*, which are out of reach. See *Deck-sash opener*.

Sash parting-strip. A strip of wood attached to the window-post of a passenger-car which acts as a distance-piece between two sashes and against which the latter slide. Also called *bead* and *parting bead*, which see.

Sash-pivot. Figs. 4351-64. A metal pin or pivot attached to a sash on which the latter turns. The term almost always means a *deck-sash pivot*.

Sash-spring. Figs. 4403-5. The inter-car, between the

Sash-prop. A *window button*, which see.

Sash-pull. Figs. 4342-50. See *Deck-sash pull*.

Sash-pull hook. Figs. 4376-80. See *Pull-hook*.

Sash-rail. 12, fig. 2451. A horizontal bar in the outside frame of a window or blind. See *Window-blind rail*.

Sash-rest (street-cars). See *Window-sash rest*.

Sash-spring. Figs. 4403-5. A metal spring attached to the edge of the stile of a window or blind sash to prevent it from rattling. They are made of various forms. A *single window-sash spring* consists of a metal plate, like fig. 4405, attached to the sash at one end. A *double window-sash spring* is a metal plate fastened in its center to the sash. Another is of a spiral form, *spiral window-sash springs*, let into the sash.

"**Savage**" lamp-burner. Fig. 3379. One of the no-chimney burners.

Scantling (carpentry). "Lumber under 5 inches square used for studs, braces, ties, etc. It is expressed in terms of its transverse dimensions."—*Knight*. An upright scantling is termed a *stud*.

Scarf. "A joint uniting two pieces of timber endwise. The ends of each are beveled off and projections are sometimes made in the one corresponding to concavities in the other, or a corresponding concavity in each receives a jiggle" (or packing-block).—*Knight*. It is technically known as a *ship-splice*, prescribed by the rules for interchange of traffic for splicing any broken sills but the center sills. See *Interchange of Traffic* for the splice recommended for sills.

Scarritt-Forney seats. Figs. 3968-76. Seats made by the Scarritt Furniture Company under the Forney patents. The feature of the Forney-seat is the seat back arms and the tilting of the cushion and inclinations of the back given by these arms. This is fully shown in the figures. Another feature of these seats is the *adjustable foot-rest*, which permits luggage to be set under it out of the way as shown in fig. 3972.

Scheme-rod (postal-cars). A rod supported upon the *scheme-rod bracket*, and carrying the *scheme* or schedule of the proper distribution of mail matter for the various post-offices used in distributing mail.

Schoen's pressed steel. Body and truck-bolsters; Brake-beam, figs. 1575-80; Brake-Shoes, figs. 5185-6; Bolster-columns, figs. 5184-5; Center-plates, figs. 5176-82; Journal box, figs. 5161-4, 5183, etc.

The parts are made of a mild low carbon steel in dies, under hydraulic pressure. Many of them require a number of operations to produce the desired form. The advantages claimed over malleable iron are greatly increased tensile strength, and therefore lighter and better shapes. The tensile strength claimed for pressed steel is 60,000 to 65,000 lbs. per square inch.

Schroyer-Thompson piston-travel indicator. Figs. 1778-82. See *Piston-travel indicator*.

Scraper. See *Snow-scraper*.

Screen. 1. (For heater-room doors, wash-room panels, etc.) Fig. 3639. A perforated plate of sheet metal, usually *japanned*, which see, used as an ornamental finish.

2. (For hood of Spear-heaters). A perforated plate or wire netting, through which the air admitted is screened to exclude cinders.

Screen, deck-window. S, fig. 540-1. A wire netting extending the entire length of the clear-story outside the deck-sash to exclude cinders. It is usually a very fine wire netting, 64 meshes to the inch.

Screw. 1. "A cylinder surrounded by a spiral ridge or groove, every part of which forms an equal angle with the axis of the cylinder, so that if developed on a plane surface it would be an inclined plane. It is considered as one of the mechanical powers."—*Knight*. When used alone the term commonly means a *wood-screw*, having a slotted head and gimlet point, for driving in with a screw-driver. *Machine screws* are similar, except that

they have no gimlet point and have a metal screw-thread. They are used for uniting metallic parts. All ordinary forms of bolts have screw-threads cut on them, but are not commonly called screws. A special form of wood-screw is a *lag-screw*, fig. 3711, which is a large-sized screw with a head like a bolt, so that it may be inserted with a wrench instead of a screw-driver. See *Screw-thread*.

2. See *Oil-screw*.

Screw-burner. Figs. 3376-7, etc. A lamp-burner to which the chimney is fastened by a small screw passing over a lip or rim on the bottom of a chimney. It is the oldest form of burner, but now little used. See *Lamp-burner*.

Screw-coupling (English). 41 to 45, figs. 501-4. The means by which passenger train vehicles are coupled together. On the Continent it is used for both passenger and freight cars. It comprises a right and left handed screw provided with a hinged weighted handle, which always hangs downward, so that it has no tendency to unscrew and slacken the coupling, and two nuts with gudgeons taking in the eyes of U-shaped coupling links or shackles. The screw-coupling may be either loose, or one shackle may be attached to the drawbar.

Screw-coupling nut, and gudgeons (English). 44, figs. 501-4. See above.

Screw-coupling weighted lever (English). 45, figs. 501-4. See above.

Screw-gages. Instruments for measuring the diameter or size of screws. They are of two kinds: *external*, for measuring male screws, and *internal*, for measuring female screws. See also *Screw-pitch gauge*. *Screw-thread gauge*.

Screw-jack. Figs. 3733, 3736-9, 3743-4. A jack, the power of which depends upon a screw, turned by a lever. There are several such jacks in use, the *Bell-base*, *Ratchet screw-jack*, the *Differential screw-jack*, which has two screws, one working within the other, and the Chapman screw-jack, which has a capstans head, into which a bar may be inserted.

Screw-pitch gage. "A gage for determining the number of threads to the inch on screws and taps. It consists of a number of toothed plates turning on a common pivot, so that the serrated edge of each may be applied to the screw until one is found which corresponds therewith. The figures stamped on the plate indicate the number of threads to the inch."—*Knicht*. In the ordinary single thread screw the pitch is indicated by the number of threads to an inch.

Screw-thread. Figs. 5492-8. The groove, or the material between the grooves, which is cut on the outside surface of a cylinder to form a male screw, or on the inside surface of a cylindrical hole to form a nut or female screw. *Metal* screw-threads and *wood* screw-threads, which see, are of different form. *Pipe* screw-threads, which see, are usually V-shaped, but all other threads in common use for ordinary purposes are made by the *Whitworth* or *Sellers standard screw-threads*, which see, the former being the European and the latter the American standard.

At the M. C. B. Convention, 1882, it was "Resolved, That this Association deprecates the use of screws larger or smaller in diameter by a small fraction of an inch than the sizes specified for the Sellers or Franklin Institute system, and that all the members of the Association are urged to abandon entirely the use of over or under size screws."

The Sellers or Franklin Institute system of screw threads, bolt heads and nuts is the standard of the Association, and repeated action of the Association has deprecated the use of any other system, and encouraged the careful maintenance of these standards. See Proceedings 1872, page 18 and 21; Proceedings 1879, pages 82 and 83; Proceedings 1882, page 229.

A set of gauges for standard screw threads and a standard inch scale, 2 feet long, are held in the office of the Secretary for reference.

Mr. Sellers, who proposed this system of screw threads, de-

scribed it in an essay read before the Franklin Institute of Philadelphia, April 21, 1864, as follows:

"The proportions for the proposed thread and its comparative relation to the sharp and rounded threads will be readily understood from the diagrams, figs. 5492-7. The angle of the proposed thread is fixed at 60 degrees, the same as the sharp thread, it being more readily obtained than 55 degrees, and more in accordance with the general practice in this country. Divide the pitch, or which is the same thing, the side of the thread into eight equal parts, take off one part from the top and fill in one part in the bottom of the thread, then the flat top and bottom will equal one-eighth of the pitch; the wearing surface will be three-quarters of the pitch, and the diameter of screw at bottom of the thread will be expressed by the formula:

$$\text{Diameter, } \frac{1.299}{\text{Number of threads per inch.}}$$

The tables, figs. 5498, are reprinted from Mr. Sellers' essay; they give the proportions of his standard screw threads, nuts and bolt heads.

The *Sellers* or *Franklin Institute System* is also called the *United States standard system*.

Screw-thread gage. A steel plate with notches in the edge of the precise form of screw-threads, used for giving the proper form to the edges of screw-cutting tools. See *Sellers' screw-thread* and *Screw-threads*.

Screw-top (bell-cord hangers). 2505-7. A simple form of *bell-cord hanger bracket*, which see.

Scribing. The fitting of the edge of a piece of timber or metal to another more or less irregular surface. Scribing is usually done by marking a parallel line to the surface which it is designed to fit by a pair of compasses or with a *scribe-awl*.

Scroll-iron (English). 88, 90, fig. 501. A wrought-iron forging, carrying a vertical *spring-link adjusting-screw*. The form shown is a special pattern. The upper face is attached to the under side of the sole-bar, and the lower part is bored horizontally for the *adjusting-screw*. In general use on passenger service.

Scutcheon (of a lock). Fig. 2621-7. Properly, *escutcheon*, which see.

Seals. Figs. 3877-93. See *Car-seals*. See also *Glass-seal*, *Lead-seal*, *Lock-seal*, *Rivet-seal*.

Seal-holder. Figs. 2745-6, 3897. See *Paper-and-glass seal holder*.

Seal-lock (freight car). Figs. 3898-99a. A lock in which a seal made of glass, paper, or other material is inserted in the lock in such a manner as to cover the bolt or the key hole. The lock cannot be opened without breaking the seal. See *Car-seal*.

Seal-press. Fig. 3894-6. A pair of levers arranged like a pair of pincers, with two dies in which lead car-seals are compressed on the wire to which they are attached, leaving an impression on the lead so that if the seals are removed or defaced it can be known. Similar seal-presses are used for eyelet shackles.

Seal-wires. Fig. 3900. Several strands of fine wire twisted together like a rope, or single bars of twisted flat wire, by which leaden seals are attached to car-doors. There are various special forms, called *detective wires*, as figs. 3886-7a, to prevent stripping the seal.

Seal-wire opening (car-door fastener). A hole for inserting the shackle of a seal.

Seaming-lace (English). 205, figs. 501-4. An ornamental woolen fabric made in bands about $\frac{1}{4}$ inch wide, and used to cover the seams and joints in the upholstery of a carriage. It is sewn to any textile fabric and has two tape edges, and is wrapped round a piece of seaming-cord which is stitched inside. It differs from *pasting-lace*, which see.

Searle heater. A heater which relied upon the circulation of hot water through the car. The water was kept from freezing by the addition of salt. It had a strong general similarity to the old *Baker heater*. The especial features claimed for the heater were the arrangement of the *expansion-drum* and some similar minor details. It is quite out of use.

Seat. 1. "That on which one sits."—*Webster*.

2. Figs. 3901-4115. "The flat portion of a chair or sofa

to support the person."—*Knight*. See *Car-seat*, special forms, which also see, being—

<i>Bushnell's seats.</i>	<i>Reversible seat.</i>
<i>Cane seat.</i>	<i>Revolving chair.</i>
<i>Corner-seat.</i>	<i>Right and left hand seat.</i>
<i>Forney's seats.</i>	<i>Roberts' seats.</i>
<i>Hale and Kilburn seats.</i>	<i>Scarritt-Forney seats.</i>
<i>Hartley chair.</i>	<i>Scarritt seats.</i>
<i>Hitchcock chair.</i>	<i>Side-seat.</i>
<i>Longitudinal seat.</i>	<i>Slat-seat.</i>
<i>Parlor-car chairs.</i>	<i>Wakefield rattan-seats.</i>
<i>Perforated-veneer seat.</i>	<i>Wheeler seats, etc.</i>
<i>Rattan-seat.</i>	

See also *Saloon-seat*.

3. In *Mechanics*: "The part on which another thing rests, as a *valve-seat*."—*Knight*.

See <i>Axle-seat.</i>	<i>Rubber-seat.</i>
<i>Bolster-spring seat.</i>	<i>Side-seat.</i>
<i>Discharge-valve seat.</i>	<i>Slat-seat.</i>
<i>Equalizing-bar seat.</i>	<i>Spring-seat.</i>
<i>Equalizing-bar spring-seat.</i>	<i>Tank-valve seat.</i>
<i>Leather-seat.</i>	<i>Wheel-seat.</i>

4. (For hand-car.) 12, figs. 5995-7. A horizontal board placed lengthwise over the wheels above a *rave*, for the occupants to sit on.

Seat-arm. 9, figs. 3917-25, figs. 4099-4102. An arm by which the back of a seat is attached to the *seat-end* or to the side of the car. Such arms are usually attached by a *pivot*, so that the seat-back can be reversed. Sometimes called *striker-arm*, *seat-back arm* and also *seat-back reversing-arms*. Special forms of seat-arms are *Cobb's pivoted seat-arm*, fig. 4093, designed to enable the back to be raised higher; *Gardner's geared seat-arm*, fig. 3995, designed to change the slant of the seat when the back is reversed, and *Buntin's seat-arm*, fig. 3993, which unites the seat and seat-back in one piece. These are all old patterns. Later forms are the *Forney*, figs. 4099-4102, 3968, etc.; the *Swing-back*, figs. 3981-3, etc.; the *Hale & Kilburn*, figs. 3919-20; and the *Walk-over* (H. & K.'s), figs. 3917-18.

This term is also used to designate the portion of a seat-end (more properly called *seat-end arm*), which supports the arm of a person sitting in the seat, as 3, figs. 3917-25; and sometimes, incorrectly, to designate an *arm-cap*, figs. 4017-21, which see.

Seat-arm cap. A piece of metal shaped to the form of the seat-arm and screwed to the top to take the wear and as an ornament.

Seat-arm pivot. Figs. 4034-50. A metal pivot by which a *seat-arm* of a reversible seat is attached to a *seat-end* or the side of a car. In some cases, as figs. 4081-5, the pivot is made in one piece with the *seat-arm plate*, which is attached to the seat-end. The two combined then become a *seat-arm pivot-plate*, which see. A *seat-back arm pivot* or *swing-joint* is used in *Cobb's pivoted seat-arm*, fig. 4093. A seat-arm pivot is sometimes called in the trade a *seat-arm rivet*.

Seat-arm pivot-plate. Figs. 4077-86. See above.

NOTE.—Figs. 4069, 4077, 4080 and 4086 should be entitled in the engravings seat-arm plate instead of seat-arm pivot-plate, since they carry no pivots attached to them. Figs. 4081-4 is a true seat-arm pivot-plate.

Seat-arm plate. Figs. 4069, etc. A plate fastened to a seat-end with a hole in the center, which receives and holds a *seat-arm pivot*. In some cases the pivot is made in one piece with the plate. The part formed by combining the two is then called a *seat-arm pivot-plate*, which see, sometimes a *seat-arm pivot-plate* or *washer* and a bolt is used, fig. 4043, 4047-50. See also note to *seat-arm pivot-plate*.

Seat arm-rest bracket. Figs. 4014-16. A bracket to be screwed to the wall to carry a wood arm-rest.

Seat-arm rivet. See *Seat-arm pivot*.

Seat-arm rocker (*Cobb's pivoted seat-arm*). A bar resembling the rear portion of an ordinary seat-arm, which is attached to the seat-arm proper by a *swing-joint* or

A metal lug or sometimes to the

side of the car on which the *seat-arm* rests. Seat-stops are either attached to a long plate (*curved* or *straight seat-stop*), as in figs. 4051-9, etc., or as in *round seat-stops*, figs. 4063-9, etc., and have a flange entire surrounding them, by which they are attached to the seat-arm or side of the car. They are made in a variety of forms shown in figs. 4051-76. They are also called *seat-stops*.

Seat-arm thimbles. Figs. 4040-1.

Seat-arm washer. A small washer for the head of a screw by which a seat-arm is fastened to a seat-end. Now little used.

Seat-back. Figs. 4044-9. That part of an ordinary American car-seat which forms a support for the back. It has an arm called the *seat-back arm* attached to it, by which it is attached to the *seat-ends* with a *seat-arm pivot*, so that it can be swung over so as to face the other way. In some styles the seat-back arm is pivoted below the seat cushion and the seat-back swings over the cushion so that both sides are used alternately. See *Seat*. On some suburban cars, and usually on street-cars, *longitudinal* seats are used, with the backs against the side of the car. See *Slat seat-back*. *Flexible-top seat-back*. *Sectional seat-back*. The *Buntin seat*, which see, has the seat and seat-back in one.

Seat-back arm. A *seat-arm*, which see.

Seat-back-arm lock. See *Seat-lock*.

Seat-back-arm pivot. 1. Pivoted seat-arm. Figs. 4092-3. The *swing-joint* or *seat-back pivot* in the seat-arm.

2. A *Seat-arm pivot*, which see.

Seat-back band. Figs. 4023-8. A *seat-back molding*, which see.

Seat-back board (street cars). 109, figs. 5654-67. A board placed between the two *seat-back rails* of a longitudinal seat. Usually made in the form of a raised panel so as to make a comfortable rest for the back. A *seat-back*.

Seat-back bottom-rail. 111, figs. 5654-67. See *Back-seat bottom-rail*. Also called a Lower seat-back rail.

Seat-back corner (emigrant sleeping-cars). A brass corner-plate carrying a lug to guide the back when making up the seats into berths.

Seat-back corners. Figs. 4103-4. A metallic corner-piece to screw to the backs of seats and protect the upholstery from wear.

Seat-back curved-stop. Figs. 4053-7. A seat-back stop, which see, of a curved form, resembling somewhat a letter S.

Seat-back molding. Figs. 4023-8. A wood or (usually) metal band or molding fastened around the edge of a seat-back to give it a finish and protect it from wear.

Seat-back pivot (*Cobb's striker-arm*). The pin by which the seat-arm is pivoted to the back. See *Cobb's pivoted seat-arm*. It should not be confused with a *seat-arm pivot*, which see.

Seat-back rail (street-cars). 110-11, figs. 5654-67. Two narrow rails, *upper* and *lower*, which form the top and bottom of a longitudinal seat inclosing the *seat-back board* between them.

Seat-back reversing arms. 9, figs. 3967-76. A *seat-back arm* of a Scarritt-Forney seat.

Seat-back round-stop. Figs. 4065-8. A round *seat-stop*, which see.

Seat-back slats. Figs. 3982. Narrow strips of wood used to form a seat-back; used chiefly for seats which are not upholstered.

Seat-back spring. A weak spring placed in the upholstering in the back of a seat. Usually called simply *back-spring*.

Seat-back stop. See *Seat-stop*.

Seat-back top-rail. 112, fig. 5656.

Seat-bearing cross-bar. 100, fig. 5656. (Longitudinal seat of street-car.) The bearing bar transverse to the seat and resting upon the *seat-leg* and the *back-seat rail*.

Seat-board (English). 150, figs. 501-4. In a carriage, the support for the *seat sofa-springs*. These springs are

- tied down, and a piece of canvas is stretched tightly over them, the cushion resting on this canvas.
- Seat-bottom** (street-cars). 95, figs. 5654-7. The boards or floor in a seat-frame on which a cushion rests, or on which persons sit when no cushion is used. It is attached to the *back* and *front seat-bottom rails*.
- Seat-bottom rail**. See above.
- Seat-bottom cross-bar**. 101, fig. 5656. A filling piece shaped like the seat-bottom, to which the slats are screwed. It rests upon or over the *seat-bearing cross-bar*.
- Seat-bracket** (hand-car). 13, figs. 5595-7. A wrought-iron knee which supports the seat.
- Seat-bracket brace** (hand-car). 14, figs. 5595-7.
- Seat-cord** (Mann boudoir-car). 5, fig. 2418. A cord used to hold up the lower seat while removing the bedding for night use.
- Seat-cove**. 99, fig. 5656. The rail that takes the place of the back-seat bottom slat.
- Seat-cover** (street car). A piece of tapestry or seat covering with which the bare seat is often covered.
- Seat-cover guard-rail**. 103b, fig. 5667. A strip of wood tacked to the flap of the seat-cover to keep it straight.
- Seat-corner**. Fig. 4105. A metal corner plate to protect the wood corner from abrasion.
- Seat-cushion**. 1. Figs. 3917, 3929-38. A soft pad or pillow on which passengers sit. Two kinds of cushions are used on cars; a *squab-cushion*, which is a loose pad and is now little used, and *box-cushion*, which is a cushion built upon a *cushion-frame*, with springs, etc. See *Back-squab* (English).
- A great variety of forms of seat-cushions exist, the leading ones of which are shown. Special forms, separately defined, are, as respects material, *woven wire*, *rattan* or *cane*, *canvas-lined*; as respects mode of construction, *flexible-top*, *elliptic*, *broad-band elliptic*, *spiral-elliptic*, *Bushnell*, *spring-edge*, *sectional*, *drop-down frame*, etc., etc.
2. (English.) 196, figs. 501-4. American equivalent, squab cushion. In a first-class carriage, a flat, loose squab cushion, about four inches thick, covered with broadcloth on one side and leather on the other, and stuffed with curled horse hair. It is *reversible*, and often so called.
- Seat-division** (longitudinal seats). Shown in figs. 99 and 464-6. A bar of wood or metal to separate the space occupied by a passenger from that adjoining it.
- Seat-end**. 123, figs. 540-1; 3, figs. 3917-25, 4106. A frame of wood or metal at the end of a car-seat which supports the arm of the occupant and to which the seat-back arm is attached. Seat-ends are designated *long* or *short*, according to whether they extend entirely to the floor or are supported upon a *seat-stand*. They are also designated as *aisle seat-ends*, or *wall seat-ends*, and, for corner seats, as *left-hand* or *right-hand seat-ends*, which see.
- Seat-end arm**. 4, figs. 3917-25. The portion of a seat-end which supports the arm of a person sitting in the seat. An *arm-rest*.
- Seat-end panel-rib** (open street-car). 254, fig. 5659. A piece of furring to which the *seat-end panel* of an open car is fastened.
- Seat-end** (cross) rail. 6, figs. 3917-20; 255, fig. 5659. The end-rail between the posts of a *wood seat-end*.
- Seat-end rest**. 5, figs. 3917-25. The end-posts or upright members of a *wood seat-frame*.
- Seat-frame** (Hartley chair, which see). 12, figs. 3998-9. See *Pedestal*.
- Seat-front** (street-car). 102, figs. 5656. The rave or seat riser.
- Seat-front rail**. 103, fig. 5656. A rail fastened to the ends of the seat-bearing cross-bar and running along at the top of the *seat-front* and under the *front-seat rail*.
- Seat-front panel** (street-car). 104, fig. 5666. The panel beneath the seat, the same as a *rest-front*.
- Seat-hinge** (sleeping-cars). Figs. 4111, 4257. A strap-hinge used to connect a seat with the seat-back. See also *Sofa-hinge*.
- Seating**. Fig. 3942. See *Canvas-lined rattan-seating*. The *plush* which is commonly used to upholster car-seats is also sometimes called seating.
- Seat-joint bolt**. Fig. 4042. A bolt for fastening a *seat-rail* to *aisle seat-ends*. It is also used at the wall ends.
- Seat-leg** (longitudinal seats). 96, figs. 5654-67. A wooden post which supports a front seat-rail.
- Seat-leg plate**. A metal plate with which the front of a seat-end or leg is covered to protect it from injury.
- Seat-lever** (Howard's parlor-car water-closet). Figs. 3838-9. A lever projecting backward from the seat-lid, to which the *connecting-rod* is attached.
- Seat-lid** (Howard's parlor-car water-closet). Figs. 3838-9. A lid connected with the *pan* and *service-measure* by the *connecting-rod* in such a manner that on raising it the pan is brought up into position and about half a gallon of water is discharged from the service-measure.
- Seat-lock**. Figs. 4029-33. A lock for holding the back of a seat so that its position cannot be reversed. Such locks are attached either to the seat-end, seat-back arm, or seat-back stop. A form for iron seat-ends with a smaller escutcheon, not provided with screw-holes, is sometimes distinctively called a *barrel-lock*, although the term is almost equally applicable to any form of seat-lock. Seat-locks operate by pushing the key inward, turning it a little, and then pulling on the key.
- Seat-lock bolt**. Fig. 4029. The beveled bolt by which locking is effected.
- Seat-lock key**. A key for a seat-lock. Some work by pushing in and not turning; others, see *Seat-lock*.
- Seat-lock spring**. Fig. 4029. The spring which moves the bolt.
- Seat-pull** (sleeping-cars). Figs. 4041-2. A flush handle for pulling out the seat in making up the berth so as to drop the back and seat to the same level.
- Seat-rail**. 48, figs. 3920-3; 97, 98, figs. 5654-67. One of a pair of wooden rails, *front* and *back*, resting on and attached to the seat-end and to the side of the car, and which supports a cushion-frame or seat-bottom.
- Seat-rail bracket**. A support for a wooden seat-rail. In iron seat ends it is frequently cast upon it.
- Seat-rail knee** (English). 119, figs. 501-4. A piece of wood secured to the door pillar and supporting the seat-rail. It is generally slotted to receive a leather-strap, restraining the undue opening of the door.
- Seat-rail support** (English). 119, figs. 501-4. A piece of hard wood supporting the seat and securing it to the side of the body of a carriage. It is often pierced for a leather strap limiting the opening of the door.
- Seat-riser**. 1. (Street-cars.) 102, figs. 5654-67. A vertical board or front of a seat, extending from the seat-rail to the floor; seldom used with reversible seats. A seat front.
2. (Hand-car.) 15, figs. 5495-7. A *rave*, which see.
- Seat-slat**. A narrow strip of wood which forms part of a seat-bottom, or seat-back.
- Seat-spring**. Figs. 3904-7, 3929-38, 3948-51, 3956-67, 4000-13. A spiral or other metal spring used to give a seat elasticity. *Spiral* springs are the most common, the *elliptic* and *spiral-elliptic* having become nearly obsolete in new seats. A special form of seat-springs called *back-springs*, of little resistance, is used for seat-backs. English seat-springs, 203, fig. 501, are called *sofa-springs*, and the back springs *back-squab sofa-springs*.
- Seat-stand**. 124, figs. 540-1, 4107-9. A support, usually made of cast-iron, on which an *aisle seat-end* rests. Very commonly the seat-stand and seat-end are in one part, which is then called a *long-seat end*.
- Seat-stand tie-rod**. Figs. 3967-76. A rod connecting the aisle and wall seat stands of a Scarritt-Forney seat.

Seat-stop. See *seat-arm stop*.

Seat-tilting levers. 35, figs. 3917-18. See *Parallel-rod*.

Seat-webbing. Figs. 3935, etc. A form of coarse canvas used in upholstering car-seats.

Second catch (of car-door fastener). Fig. 2744. A double hook or eye placed in the hasp of a car-door lock in such manner that the door can, if desired, be locked, leaving a crack open for ventilation.

Secondary brake-rod. 1. (Hodge brake.) 6, fig. 1463. A rod which connects one end of a floating-lever with one of the brake-levers.

2. (Elder brake.) 6, fig. 1462. A rod which connects the center brake-lever, Elder brake, with one of the brake-levers on the truck. On a four-wheel car it is the rod which connects the center lever with one of the brake-beams.

Second-class car. A plainly-finished passenger-car for carrying passengers who pay a lower rate of fare than first-class passengers do. Such cars are rarely used, the smoking car usually serving this purpose for the small number of so-called second-class (in reality, third-class) passengers. See *Coach*. *First-class car*.

Second-class carriage (English). A vehicle adapted to carry passengers paying an intermediate rate of fare, the fittings being less expensive and comfortable than in the first-class. Each compartment measures about 6 feet in the length of the carriage and seats 10 passengers. It is rapidly going out of use, so much so that several of the English roads have discontinued the running of second-class-carriages. See also *Carriage*.

Section. 1. See *Sectional seat-cushion*.

2. (Of a sleeping car.) Figs. 2408-12. Two double berths, one above the other, making up into two seats facing each other by day. There are from 8 to 12 sections in a car, generally 10, besides the state-rooms. See figs. 177, 186.

Sectional seat-cushion. Figs. 3929-38, 3948-51, 4000-8. One with spiral springs separately attached to narrow slats so that the seat can be made up or repaired in sections.

Sector. In geometry: "A part of a circle included by an arc and the two radii drawn to its extremities."—*Davies*. Hence, any object whose shape is that of a part of a circle ought to be called a sector, but as a matter of fact it is generally called a *quadrant*. See *Deck-sash quadrant*. *Drawbar sector*.

S diment well (Gold's car-heating). Fig. 3007. See *Thermostatic steam-trap*, etc.

Self-acting ventilator. Figs. 4299-29a. An *automatic-ventilator*, which see.

Self-adjusting spring (brake) head. Figs. 1609-11, 1616a-f. A brake head which fits a *ratchet sleeve* and which contains a *spring pawl* with sharp projections which engages in the indentation of the ratchet sleeve and allows the head to adjust itself to the wheel, but which shortly beds itself and holds the head firmly in one position.

Self-closing faucet, or cock. Fig. 3492. A faucet having a horizontal bar-handle provided with a spring by which it is closed when released. *Telegraph-cocks*, which see, figs. 3489-90, and also *compression-cocks*, fig. 3485, are also self-closing, but not distinctively so-called.

Self-locking or spring padlock. Figs. 2768-70. One which snaps, locked by pressure only, without using a key, in distinction from a *dead padlock*.

Sellers system of screw threads. Figs. 5492-8. A system of screw threads designed by William Sellers, of Philadelphia. The following table gives the number of threads to the inch and the proportion of the threads of the Sellers system. See also fig. 5498.

The form of the threads is an essential part of the system and is shown in fig. 5497. The angle at which the threads stand to each other is 60 degrees, and the threads are made flat.

The form of the threads are determined by the

TABLE GIVING PROPORTIONS OF THE SELLERS SYSTEM OF SCREW THREADS.

Outside diameter of screw in inches.....	Number of threads per inch.....	Diameter of screw at the root of the thread in decimals of an inch.....	Width of top and bottom of thread in decimals of an inch.....	Outside diameter of screw in inches.....	Number of threads per inch.....	Diameter of screw at the root of the thread in decimals of an inch.....	Width of top and bottom of thread in decimals of an inch.....
1/4	20	.185	.0062	1	8	.837	.0156
5/16	18	.240	.0074	1 1/16	7	.940	.0178
3/8	16	.294	.0078	1 1/8	6	1.065	.0178
7/16	14	.344	.0089	1 1/4	5	1.160	.0208
1/2	13	.400	.0096	1 1/2	4 1/2	1.284	.0208
9/16	12	.454	.0104	1 3/8	4	1.389	.0227
5/8	11	.507	.0113	1 1/2	3 1/2	1.491	.0250
3/4	10	.560	.0125	1 3/4	3	1.616	.0250
7/8	9	.731	.0138	2	2 1/2	1.712	.0277

following rule given by Mr. Sellers: "Divide the pitch, or, what is the same thing, the sides of the thread, into eight equal parts; take off one part from the top and fill in one part in the bottom of the thread; then the flat top and bottom will equal one-eighth of the pitch, the wearing surface will be three-quarters of the pitch, and the diameter of screw at bottom of the thread will be expressed by the formula:

$$D = \frac{1.299}{N},$$

in which D = diameter of the screw and N = the number of threads per inch."

This system was recommended by a committee appointed by the Franklin Institute in 1864; was adopted as the standard by both the Army and Navy departments of the United States, and has been recommended by both the Master Car Builders' and the Master Mechanics' associations as the standard to be used in the construction of cars and locomotives. It is often called the *Franklin Institute standard* and also the *United States standard*; but, as it was designed by Mr. Sellers, it should be known as the *Sellers system*. See *Screw-thread*.

Semaphore lens. Figs. 3442-3. A trade name for a cheap modification of the Fresnel lens, the latter term being more generally restricted to those having the back a plane or nearly cylindrical surface.

Service-measure (Howard's parlor-car water-closet). Figs. 3838-9. An auxiliary tank holding about a half-gallon of water connected with the seat-lid and water-tank and discharging the water on raising the lid only.

Set (of elliptic springs). 2, fig. 5230. The amount of compression of which the spring is capable. The distance between the *spring-bands* when unloaded. The *arch* is half the set, plus the thickness of the spring-band.

Set of springs. All the springs for carrying the weight of one car, not including draw-springs. A *set of bolster-springs* consists of the springs which are placed between the truck-frames and carry the weight of the body only. A *set of equalizing-bar springs* means all the springs for a car on the equalizing-bars. A *set of wheel or journal springs* means all the springs which are placed directly over the journal-boxes of one car.

Set of wheels. This term means a number of wheels sufficient for one car. A *set of wheels and axles* means the requisite number of wheels fitted to axles complete for one car. A *pair of wheels* means two wheels already fitted to an axle, including the axle; but a *set of wheels* does not include the axles unless specified.

Set-screw, or stud-fastening (English). Figs. 5345-6. As applied to railroad wheels, a mode of securing the tire to the wheel which is becoming obsolete. A modification is the *set-screw fastening* (English), *plain-end*, fig. 5346. Though superior to the other, it is being superseded by better methods. See *Tire-fastening*.

Setting-die (for carpet eyelets). No illustration. A device, one form of which is very similar to fig. 2853-4, for forming eyelets by compressing the grommets together. Usually, however, with large eyelets, it is done with a hammer.

Seven-group spiral-spring. See *Spiral-spring*.

Sewell steam-coupling. Figs. 2990-5. This is a straight-port, abutting-face, and insulated steam-coupler. The cuts show its construction. The passage for steam is unobstructed. On the coupler-head are a tooth and space in such a position as to serve the double purpose of a guide for the interlocking devices when being coupled, and also to retain the coupler-heads in proper relation while uncoupling. The locking features are constructed upon epicycloidal curves, thereby drawing the gaskets together in a direct line after contact. The center line of pressure exactly coincides with the center line through the locking devices, and hence gravity tightens the gasket faces. The coupler is automatic in uncoupling in consequence of the curvature of the hose-nipple, the center line of draft being brought above the center line of pressure as soon as hose begins to approach a horizontal position. The gaskets are of rubber.

Sextuple (of elliptic springs). Six elliptic springs coupled together, side by side, to act as one.

Shackle. 1. (Of a padlock.) **A**, figs. 2771-2, etc. **A** U-shaped bar which is passed through the *staple* in front of the *hasp* by which the padlock is used to lock the object. The inner end **D** of the shackle is termed the *heel*, which is sometimes provided with the *shackle-spring* **G** and **I** to hold the shackle open or shut.

The shackle of cheap padlocks is attached to projecting *ears*, but in those of better quality the heel is entirely within the lock itself. The shackle is sometimes termed the *hasp*, but this usage is incorrect.

2. (Of car-seals.) Figs. 3877-89a. The wire or metal strip passing through the fastening to be sealed and closed together at the end. See *Car-seal*.

Shackle-bar. A *coupling-link*, which see.

Shackle-guard (of a padlock). A plate used in some padlocks lying immediately under the point of the shackle when locked in place, serving to exclude dirt and wet from the interior.

Shackle-lock (car-door fastener). A term used in distinction from the seal-lock.

Shackle-spring. **D** and **G**, figs. 2771-2. See *Shackle*.

Shackle-stop (Miller's padlock). **H**, figs. 2768-70. A stop to prevent the shackle escaping too far in unlocking.

Shade. See *Lamp-shade*, figs. 3423-5. *Window-shade*, figs. 4546-62.

Shade-cap (of a lamp). **33**, figs. 3261-3317. A vertical tube extending the shade upward and constituting in effect an extension of the chimney. A similar part for a lamp-globe is called a *globe-chimney*.

Shade-holders (Pintsch system). **80-A**, fig. 3231, is for postal-car shade. **80**, fig. 3232, only.

Holder **80-B**, fig. 3217, is for use with 4-in. globe **102**, fig. 3216, on any bracket-lamp. Contains a check-screw for adjustment of the flame.

Shade-ring. Figs. 3435-7. See *Adjustable shade-ring*. Also called *wire tripod*.

Shade-roller (for window shades). Fig. 4565. A device serving the purpose which its name implies, the only forms of which now in general use are the *automatic* forms, which hold the shade in any position when released by means of *centrifugal-pawls*, which see. The leading styles are the *Hartshorn* shade-roller and the *McKay* shade-roller, which see. The Hartshorn works with a pawl on the end, while the McKay has a cam. See *Burrows* and *Davis car-shades*.

Shaft. "That part of a machine to which motion is communicated by torsion."—*Webster*.

See *Brake-shaft*.
Crank-shaft.
Door-shaft.
Driving-shaft.

Drum-shaft.
Horizontal brake-shaft.
Lever-shaft (street-cars).
Winding-shaft.

Shaker. Fig. 2893d, etc. See *Grate-shaker*. *Shaker-handle*.

Shank (Kirby's car-door lock). **A**, fig. 2628. The spindle. See also *Buffer-shank*. *Grate-shank*. *Lock-shank*.

Shank. (of a coupler or drawbar). That part of a coupler or drawbar between the *draw-head* and tail-end. The body of the coupler. It may be round, square, and corrugated in different couplers.

Shank-facing (Kirby's car-door lock). **P**, fig. 2628.

Shear beams. (Snow-plow framing.) **13b**, **14**, **15**, figs. 410-3. The timbers forming the inclined plane and parting ridge of a plow. They are placed in positions so that they resemble the knives of a pair of shears, hence the name.

Shears (of a pile-driver car). Figs. 401-4. The tongs which grasp the *hammer*, which see.

Sheathing. **52**, figs. 229-66, etc.; **70a**, figs. 435-73. Boards which are tongued and grooved, and with which the sides of cars are covered. The sides of a gondola car are ordinarily termed *side-plank* and *end-plank*, and are much heavier than the sheathing of a box-car. *Inside lining*, which see, is in addition to the ordinary outside sheathing. Formerly passenger-cars were covered with panels, but it is now the universal practice to use sheathing.

Sheathing-furring. **59**, figs. 435-73. Pieces of wood nailed, screwed, or glued in a wall to nail the sheathing to, inserted where the distance between rails is so great as to require intermediate pieces to back up the sheathing. Corresponds to *panel-furring*, which see.

Sheathing rail. See *panel-furring*. A *sheathing-rail*, or *sheathing-furring* is the same as a *panel-rail* or a *panel-furring*, the paneling having been superseded by sheathing.

Sheathing-strips. **69**, figs. 435-73. It should read *panel strips*, which see.

Sheave. A wheel, roller, or pulley over which a cord or rope runs, or on which any object, as a door or window, rolls. *Sheave* is often used to designate a block or pulley, but more properly it designates simply the grooved wheel in the block. See *Pulley*.

See also *Bell-cord sheave*. *Main sheave*.
Brake-lever sheave. *Pile-hoisting sheave*.
Brake-shaft chain-sheave. *Sliding-door sheave*.
Center brake-lever sheave. *Strap-sheave*.
Door-sheave.

Sheave-hook (derrick-cars). **2**, 389-96. The hook carried at the lower end of a *hoisting-block* to which the load is attached.

Sheave-pin, or *pin*. The axle of a sheave. See *Pin*.

Sheet-iron. Iron rolled thin and, in car work, usually *galvanized*. Its thickness is given by its number of *wire gage*, which see. The standard sizes are 6 and 8 ft. long and 24, 26, 28, and 30 in. wide. It is, however, manufactured to order up to 10 ft. long and 44 in. wide. *Sheet steel*, galvanized or not, is now also largely manufactured.

Sheet-ring and staple (English). **80**, figs. 348-51. A small wrought-iron ring to which are tied the cords attached to the edges of the tarpaulin protecting the contents of an open wagon from the rain.

Sheffield hand-car. Figs. 5585-88, 5605-8, etc. A name applied to several varieties of hand-cars, taken from the name of the designer, but more particularly applied, *first*, to an ordinary section hand-car with wooden wheels, and, *secondly*, to a three-wheel hand-car for inspection purposes.

Sheffield all-steel car-wheel (hand-cars). Figs. 5623-5. A steel wheel made from a sheet of toughened homogeneous steel, which by a series of operations is brought to the shape shown. The center is dished and radially

corrugated, the flange returned upon itself, the hub a drop forging made from a single piece of steel, additional support being given by a separate wrought-steel flange upon the opposite side of the plate. The whole is firmly bound together by steel rivets.

Sheffield wooden hand-car wheel. Figs. 5629-31. A car wheel with wooden spokes and felloe and a steel hub and tire. The steel tire is made by special machinery, the hub is forged out of solid steel, and securely bolted to the web portion of wheel. An advantage claimed for this wheel over the steel wheel is that, without any extra labor, they are practically insulated when on their axle, the wood-center portion completely insulating them, for use on roads where the block signals are in operation.

Shelf. See *Spring-shelf* (street-car journal-boxes).

Shell. See *Berth-latch shell*.

Shelled-out (car-wheels). A term applied to wheels which become rough from circular pieces shelling out of the tread, leaving a rounded flat spot, deepest at the edge, with a raised center. The M. C. B. rules for *interchange of traffic*, which see, specify that no wheel shall be condemned for this fault unless the spots are over $2\frac{1}{2}$ in. in length, or are so numerous as to endanger the safety of the wheel.

Shifting-pinion (hoisting-gear). A pinion attached to the *crank-shaft* or *driving-shaft* of a hoisting-gear which is constructed to slide laterally a few inches so as to have a slow-motion or quick-motion gear according to the position of the shifting-pinion.

Shim. A thin piece of wood or metal used as a distance-block to save more careful fitting. In track-work, shims are very largely used in order to remedy the heaving of the rails from frost. Shimming has been used in fitting on car-wheels when the wheel-seat of the axle was a little too small, but the M. C. B. rules for interchange of traffic forbid this. See *Interchange of traffic* and *Wheels*.

Shimer journal-bearing. A bearing, the shell of which is made of bronze or brass, with filling of lead and alternate layers of sheet metal previously tinned over so that in the process of manufacture the lead filling unites with the sheet metal and forms a solid bearing.

Ship splice. One of the many forms of splicing or *scarfing* broken pieces of timber. It is that selected for splicing broken car-sills under the regulations for *interchange of traffic*, which see. See *Scarf*.

Shoe. A plate, block or piece of any material on or against which an object moves, usually to prevent the latter from being worn. See *Boom-shoe*. *Brake-shoe*. *Door-shoe*.

Short-sill, or short floor-timber. Fig. 5664. An auxiliary longitudinal timber used in a car-floor, but not extending its whole length.

The term *short floor-timber* is also applied with questionable propriety to short auxiliary cross-pieces used in freight-car floors as distance-blocks between the sills and *not* extending across the whole width of the floor. Corresponding timbers in passenger-cars are termed floor-timber distance-blocks. See also *Bridging*.

Short plate-rod. Horizontal bolts passing through the *plate-bolt strip* and the *plate*, serving to stiffen the latter horizontally. It is rarely used.

Short seat-end. Figs. 4106-8. A seat-end which does not extend below the seat or support it, but is supported upon a separate *seat-stand*. See *Seat-end*.

Shot (in chilled car-wheels). See *Cold-shot*.

Shovel. 1. (Steam shovel.) Figs. 208, 405-7. A car upon which is mounted a steam derrick-frame so adjusted and connected with proper mechanism that it will scoop up bucketfuls of dirt and gravel and deposit them in a car or other conveyor.

2. (Steam shovel.) See *Steam shovel*.

3. (Steam shovel.) See *Steam shovel*.

In this country usually called *switching*. *Marshaling* which see, has a nearly similar meaning. Sometimes the word *drilling* or *regulating* is used.

Shutter (for cabin of pile-driver car). 13, figs. 401-4. A wooden cover for a window, especially one having no sash.

Side. See *Deck-side*. *Ladder-side*. *Truck-side*.

Side arm-rest, or elbow rest (English). 201, figs. 501-4.

A wooden support for the elbow attached to the inner sides of a carriage beneath the windows, and padded with horsehair and covered with broadcloth or leather. See also *Folding arm-rest*. In American cars a *window-ledge* is made to serve the same purpose, but *arm-rests*, 2409, are general in sleeping-cars.

Side-bearings. Supports placed on each side of the center-pin of a car to prevent too much rolling or rocking motion of the car-body. Usually there is a plate of iron or steel attached to the body-bolster on each side of the center-pin, called a *body side-bearing*, 16, figs. 229-66, etc.; 14, figs. 435-73—and a corresponding plate, block or roller on the truck-bolster, called the *truck side-bearing*, which see, 61, figs. 4580-4757. They are also distinguished as *lower* and *upper* side-bearings. Generally there is a little space left between the bearings, so that the truck can turn freely on the center-plate, although in some cases the weight of the car-body rests on the side-bearings instead of the center-plates. Other types are the *King's yielding side-bearing*, fig. 5190-1, and the *Hubbard anti-friction side-bearing*. To obviate friction, *cup side-bearings* are so formed as to hold a lubricant. *Rocker side-bearings* and *roller side-bearings* are also used.

Side-bearing block. Figs. 4974-5. A filling casting bolted to the truck bolster and forming an abutment for the *Truck-side bearing-bar*.

Side-bearing bridge or arch-bar (six-wheeled truck). 62, figs. 4842-4966. An iron bar, truss, or wooden beam attached to the spring-beams to support the truck side bearing.

Side-bearing roller. Fig. 4747-9. See *Side-bearing*.

Side-bearing spring. 16, figs. 339-42. (Side-dump or tip-car.) Bearing springs upon which the body bears at the side to steady the box and to receive the shock when the body is returned to its normal position after dumping.

Side bearing-timbers. L, figs. 325-7. Longitudinal or transverse floor timbers framed or bolted to the *side-posts* of a coal or ore-car, which supports the upper ends of the inclined floor planking.

Side-board. 1. (Dining-cars.) Figs. 102-3, 474-8. An ornamental receptacle for dishes, etc., usually placed so as to face the central compartment of the car. See *Buffet-car*.

2. (English.) 67, fig. 348. American equivalent, *side-plank*. A planking constituting the sides of the car.

Side-body brace. 33, figs. 229-66, etc.; 51, figs. 435-73. Commonly, simply *body-brace* or *brace*, which see, except when the *end-braces* are to be distinguished from them.

Side body-brace rod. 34, figs. 229-66. 52, figs. 435-73. See above.

Side body-truss rods. 33, figs. 298-315. See *Side truss-rod* or *Side-trussing*.

Side buffer-spring. Fig. 1403. See *Buffer-spring*.

Side-buffer stem. Figs. 1395-6 and 2290-2301.

Side-casting. See *Drawbar side-casting*.

Side chute-plank. Q, figs. 325-7. The planking of an inclined floor which discharges its load *transversely* to the car, either toward or from the middle of the car.

Side deck-lamp. Figs. 3386, 3302. A bracket-lamp fastened above the windows and to the deck-sill, or to the lower *deck-ceiling* and the *deck-post*.

Side-doors. 1. (Baggage-car.) Figs. 1792-3.

2. (Side dump-cars) 123, figs. 332-5; 62, figs. 336-42.
- Side dump-car.** Figs. 27-30, 338-42. A car so constructed that its contents may be discharged to one side of the track through side doors, either by having the floor inclined or by tipping it sidewise. See *Dump-car* and *Tip-car*.
- Side foot-rest** (passenger-cars). L, figs. 2996-3001. A metal plate fastened to the truss-plank between the seats, for passengers to rest their feet on. Chiefly used over heater-pipes as a guard to prevent the feet of passengers from coming in contact with the hot pipes. Also called *shields*.
- Side-frame.** 1. (Of a car-body.) Figs. 435-73, 531-8, 542-70, etc. The frame which forms the whole side of a car-body. It includes the posts, braces, plate, rail, girth, etc. See *Framing*.
2. (Of a truck.) Figs. 4576-4757 and figs. 4587-90, 4649-52. See *Truck side-frame*. *Diamond-truck*.
- Side-gutter, or outside-cornice** (English). 132, figs. 501-4. A piece of wood secured on the outside of the vehicle at the angle of the roof to the sides. It is channeled on the top to catch the rain and to convey it to the ends of the vehicle, to prevent it running down the sides.
- Side-gutter moulding** (English). 133, figs. 501-4. A moulding which is attached to the outside of the side-gutter in order to hide the heads of the bolts by which it is secured.
- Side journal-spring** (street-cars). One of a pair of spiral or rubber springs which rest on ledges on each side of a journal-box, as in figs. 5642, 5645, etc.
- Side-lamp.** 1. Figs. 3288-3304. A lamp attached to the side of a passenger-car. In distinction from a *center-lamp*, which hangs from the roof; they are usually made with brackets by which they can be conveniently fastened.
2. (English.) American equivalent, *side tail-light*. A colored signal lamp carried at the side of the last vehicle of a train. Two red *side-lamps* and one red *tail-lamp* are generally carried, arranged in the form of a triangle.
- Side-lamp braces.** 18, fig. 3302. Diagonal bars attached to a side-lamp and to the side of a car to steady the lamp.
- Side-lamp bracket.** 17, figs. 3288-3304. See *Side-lamp*.
- Side-lamp holder.** Fig. 3287. A metal ring or bowl-shaped receptacle usually attached to a bracket to hold a lamp.
- Side-lamp iron** (English). 184, figs. 501-4. American equivalent, *tail-light holder*. A wrought-iron lamp-holder secured to the outer side of the body to carry the colored *side-lamp*, which see. See also *Signal-lamp*.
- Side-links.** (Gould tender-hook.) 79, figs. 2145-9. Links by which the tender-hook is fastened to the buffer-head, and which permit a lateral motion of the hook. The hook is centered by springs pressing against the side-links.
- Side-piece** (for platform-hood). A thin block cut to the curve of the hood.
- Side-plank** (gondola-cars). 52, figs. 305-322. The boards bolted to the stakes constituting the sides of the car. They vary from 2 to 5 ft. in height according to its capacity and are 2½ to 3 ins. thick. Those at the end of the car are termed *end-planks*, and are usually hinged at the bottom so as to drop down inwardly on to the floor of the car.
- Side-plank tie-rod.** 36, figs. 310-15. A vertical rod passing through the side-sill and side planking and tying them together. A *side-plank tie-strap* fulfills the same office, but the planks are bolted or riveted to the plank, the end of the strap being forged round and threaded to take a nut.
- Side-plank tie-strap.** 37, figs. 305-15. See above.
- Side-plate.** 46, figs. 229-66; 98, figs. 435-73, 536-67. More properly, simply *plate*. The longitudinal stick on top of the posts of the car-body. So called as distinguished from the *end-plate*.
- Side-post strap-bolt.** 27, fig. 5654. A *strap-bolt* joining the post to the side-sill.
- Side-pulley** (of bell-cord guides, which see). 16c, figs. 339-42.
- Side-rail.** W, figs. 325-27. A longitudinal timber, extending along the top of a side-frame of a coal or ore car. It rests upon posts and braces and connects with end-rails which go across the end of the car. It corresponds to the *plate* of a *box-car*, but does not carry any rafters or carlines, as does a plate.
- Side-rest** (tip-car). 16c, figs. 339-42. A block of wood or metal, or a spring, on top of the frame on which the body rests when tipped.
- Side-seat.** Figs. 3947, 5650-8. A longitudinal car-seat, the back of which is against the side of a car. See *Car-seat*.
- Side-sills, or outside-sills.** 1, figs. 229-66, etc.; 435-73, etc. The exterior *sills*, which see. Sometimes the outside-sills only are referred to by the single word, *sill*, but this use of the word is uncommon. The side-sills are usually made deeper than the inside-sills in flat and gondola-cars, but rarely in box and stock-cars. When the side-sills are deeper than the center and intermediate sills, *bolsters* similar to figs. 1428-31, and 1433-7 are used. *Iron* side-sills are usually 8-in. *channel-bars*, and the center and intermediate sills are 8-inch *I-beams*. In passenger-cars the side-sill, and the end-sill as well, are sometimes plated with steel or iron to give greater stiffness. See figs. 428-31, 523-30, 574-83, and 1178-9.
- Side-spring** (Janney-Miller coupler). A spiral spring actuating the Miller hook laterally. The Janney coupler, from its peculiar movement of the *knuckle* or coupling-hook in coupling, requires no side-play.
- Side-spring bolt** (Janney-Miller coupler). The bolt securing the side-spring in place.
- Side-sill fitch-plank.** E, figs. 529-30. The two wood parts which enclose the *fitch-plate* and make up a *composite-side sill*.
- Side-sill fitch-plate.** B, figs. 529-30. See above and *Fitch-plate*.
- Side-spring eye-bolt** (Janney-Miller coupler). The eyes attached to the Janney *horn* in which the *side-spring stirrup* engages, for use only with the Miller hook.
- Side-spring plate** (Janney-Miller coupler). The plate or bracket sustaining the side-spring.
- Side-spring stirrup** (Janney-Miller coupler). The part inserted in the *eye-bolts* fixed to the Janney *horn* connecting the *side-spring bolt* to the Miller hook.
- Side-spring trigger** (Janney-Miller coupler). A kind of detent-latch used for relieving the tension of the side-spring while the couplers are being changed.
- Side-spring washer** (Janney-Miller coupler). A collar and cup washer used in connection with the side-spring.
- Side-step** (street-cars). 75, figs. 5654-62. A ledge usually made of a wrought-iron plate attached to the side of the platform. Also called *foot-board*.
- Side-stop.** 1. (Grain-door.) H, fig. 1867.
2. (Tip-cars.) A cast-iron support attached to the wheel-piece, on which the body rests, and by which it is held in a horizontal position.
- Side-straps** (gondola-cars). 37, figs. 298-315. The straps to which the end-plank and sometimes also the side-plank are bolted. They are also called *side-plank tie-straps*.
- Side thrust-spring.** 16c, figs. 339-42. A spring fastened to the truck-bolster or *truck-bolster raising-block*, L, to receive the thrust of the body as it is tipped in dumping.
- Side top-panel rail** (English). 117, figs. 501-4. A part of the body-framing running horizontally in the upper part of the side of a carriage.
- Side truss-rod or side-trussing.** Figs. 25, 298-315, 816-24.

A Body-side truss-rod, a horizontal truss-rod extending longitudinally along the sides and fastened to the end-planks. Its office is to prevent the sides from bulging; it is in increasing use on long gondola cars.

Side truss-rod bearings. 34, figs. 298-315. The queen-posts of the side-truss rods.

Side truss-rod block. 35, figs. 298-315. A block of wood or cast-iron inserted in the corner at the junction of the side and end-planking to guide the *side truss-rod*.

Side-urinal. Fig. 3872. A urinal to fit against the flat *side* of a room, in distinction from a *corner* urinal. The latter are almost universal in car work.

Side urinal-handle. Figs. 3845-6. So called in distinction from a *corner urinal-handle*, which see.

Siding. 1. A side track.
2. See *Sheathing*.

Signal-bell. 1. (Street-cars.) 197, fig. 5654. A saucer-shaped bell attached to each platform. They are rung by a clapper, to which a strap is attached which extends from one platform to the other.
2. (Locomotives.) A similar bell to which the *bell-cord* is attached.

Signal-hose. 29, figs. 1693-8. See *Hose*.

Signal-hose coupling. 34, figs. 1693-8. See *Hose-coupling*.

Signal-bell-cord. See *Bell-cord* and *Bell-strap*.

Signal-branch-pipe. 30, figs. 1693-8. A pipe leading from the *Train-signal pipe* to the *Car-discharge-valve*.

Signal-branch-pipe cut-out-cock. 30s, figs. 1693-8.

Signal-car discharge-valve. 32, figs. 1693-8. See *Car discharge-valve*.

Signal-cord. 31, figs. 1693-8. See *Bell-cord*.

Signal-lamp, or **signal-light**. Figs. 3318-47. A name applied to lanterns of extra power and quality of several kinds, but usually meaning those provided with *semaphore* or *bull's-eye* lenses, which see, of which from one to four are used, whence the name single-lens, double-lens, etc. They are also called *side tail-lights*, *tail-lights*, *operator's signal-lights*, etc.

Signal-lens (street-car). 270, fig. 5662. A lens in the clear-story of colored glass, behind which a lamp is placed.

Signal-pipe (Westinghouse train-signal apparatus, which see). 27, fig. 2388, 1693-4. A continuous pipe running from car to car through the train, substantially a duplicate of the brake-pipe, but working with a much lower pressure of air. The *signal-pipe couplings* are also substantially similar to brake-hose couplings, figs. 1737-41, but have a thicker lip, so that they cannot be misconnected with the brake-pipe.

Signal-pipe coupling (Westinghouse train-signal apparatus). See above.

Signal-pipe stop-cock (Westinghouse train-signal apparatus). 28, figs. 2388. A cock placed at each end of every car for closing the signal-pipe at the rear of the train.

Signal-reservoir (Westinghouse train-signal apparatus). 10E, figs. 1699-1700. A small auxiliary reservoir for operating the train signals carried on the locomotive and connected with the main reservoir through a *reducing-valve*, 24, for the purpose of reducing the pressure to about two atmospheres, which is all that is required for operating the signals.

Signal-strap (street-cars). A *bell-strap*, which see.

Signal-valve (Westinghouse train-signal apparatus). 26, fig. 2388 and fig. 2404. A valve attached to the signal-pipe on the engine, which, on the opening of the *car discharge-valve* in any car, and the consequent reduction of pressure in the signal-pipe, permits the air to escape to blow the signal-whistle, 23.

Signal-whistle (Westinghouse train-signal apparatus).
valve.

rests. The lowest timber in any structure, as the sills of a house, of a bridge, of a loom, and the like.

2. "The timber or stone at the foot of a door; the threshold.

3. "The timber or stone on which a window-frame stands, or the lowest piece in a window-frame."—*Webster*.

4. (Car-building.) Fig. 229, etc. The main longitudinal timbers, usually six, but sometimes eight in number, which are connected together transversely by the *end-sills*, *body-bolsters*, and *cross-frame tie-timbers*. Sills are divided into *side-sills*, *intermediate-sills*, and *center-sills*. A few cars, such as dump-cars and tank-cars, have but two sills, and others only four. For the splice for broken sills required by the regulations for the interchange of cars see *Interchange of Traffic*.

See also *Deck end-sill*.

Deck-sill.

End-sill.

Platform end-sill.

Platform-sill.

Platform short-sill.

Short-sill.

Swinging platform-sill.

5. The lower horizontal member of the frame surrounding a window or door. See *Door-sill*. *Window-sill*.
Sill and plank rod. 31, fig. 324a. A rod passing through the sill and planking to tie them together securely. A *side-plank tie-rod*.

Sill-and-plate rod. 36, figs. 229-66; 54, figs. 435-73, etc. A vertical iron rod which passes through the sill and plate of a car-body frame and ties the two together. A *brace straining-rod*, which see, is a similar part for low passenger-car trusses below the windows.

Sill knee-iron. 9, figs. 229-66; 8, figs. 435-73. An L-shaped or right-angled iron casting or forging bolted into the inside corner of a car-frame to strengthen it.

Sill-splice. See *Ship-splice*, and *Interchange of Traffic*.

Sill-step (freight-cars). 30, figs. 229-66, etc.; figs. 897-8.

A U-shaped iron attached to the sill of a car, below the ladder, as a step for getting to or from the ladder. In 1893 the M. C. B. Association recommended that "That two good substantial steps (*sill-steps*), made of wrought-iron, $\frac{1}{2}$ by $1\frac{1}{4}$ in. section and be fastened, one to each side-sill, next to the corner of the car to which the ladder is attached. The steps to be not less than 12 inches long, measured horizontally between the sides, and the tread to be not less than 8 inches below the bottom of the sill. The side of the step next to the corner of the car to be as near to the end of the car as is practicable. Each side of the step to be fastened to the sill with two $\frac{1}{2}$ -in. bolts and nuts."

Sill-step stay. A diagonal iron rod or bar attached to one of the sills and to a sill-step to stiffen the latter. Not commonly required or used.

Sill strap-bolt. Figs. 229-66. A strap-bolt, fig. 3712, used to fasten the side and end sills together. When set into the sill is called a joint-bolt, fig. 3720.

Sill tie-rod. 10, figs. 229-66; 9, figs. 448-73. A transverse tie-rod in the floor of a car for holding the sills together.

Simms lock (for freight-car doors). Fig. 2759.

Single-board car-roof (freight-cars). Figs. 2368-79. A roof, of which several varieties other than those shown exist, in which one layer of boards covered by some kind of sheet metal is used in place of double boards. All single-board freight roofs use a sheet metal cover, either above or below the boards, but those only having sheet metal on top are commonly so called.

Single or end berth-rest (emigrant sleeping-berths). N, figs. 2414. A bracket to support the berth when open. So called in distinction from the berth-rests proper (double) on the berth-posts.

Single-edge weather-strips. Fig. 4537. See *Weather-strip*.

Single-guard (for lanterns). According to the number of horizontal wires surrounding the globe, lanterns are designated as *single*, *double* or *triple-guard*.

Single-lever brake. Fig. 1458. A brake which has but one lever to a truck or four-wheeled car, which see, to apply to two brake-beams. In some cases applied to but one of the trucks of a car; in other cases, to both. An objection to this form of brake is that the pressure is not equal on each brake-beam. To overcome this difficulty two levers are used, and the brake, as shown in fig. 1460, is then called a *double-lever brake*, which see.

Single pipe-strap. Fig. 2936. A pipe *clip*, which see.

Single-plate wheel. Figs. 5355-61. A cast-iron wheel, in which the hub and tire are united by only a single plate, which is strengthened usually by ribs called *brackets*, figs. 5335-8, 5355, or sometimes by *corrugations*. See *Wheel. Car-wheel*.

Single sash-spring. Fig. 4405. See *Sash-spring*.

Single-screw turnbuckle. Fig. 3725. A turnbuckle, which see, shaped like a link of a chain with a screw at one end and a swivel at the other.

Single window-blind. A blind which is made in one piece or section and large enough for one window. They require a lower window, and hence are rarely used in the better grades of passenger-cars unless *flexible*, which see. See also *Window-blind*.

Single window-blind lift. Figs. 4417, 4434. See *Window-blind lift*.

Sink (dining-cars). Figs. 474-5. A shallow metallic box to receive and carry off dirty water.

Six-group spiral-spring. Fig. 5198. See *Spiral spring*.

Six-wheel truck. Figs. 4957-66; details, figs. 4967-5133. Six-wheel trucks are the standard for sleeping, parlor and dining cars. They are sometimes, though rarely, built of iron. The parts peculiar to six-wheel trucks will be seen in Roman type under fig. 4806. See *Truck. Car-truck*.

Skeleton (steel-tired wheels). Another term for the *wheel-center* or *central filling-piece*, which see. The word skeleton is principally used when the wrought or cast wheel-center consists of open bars.

Slew-back. 1. (Masonry.) The face on the edge of the abutment against which the arch proper abuts.

2. (Of a truss.) A casting on the end of a truss or a trussed beam to which a truss-rod is fastened. It is usually made in the form of a cap, and forms a bearing for the truss-rod nuts.

3. (Car-building.) A *truss-rod washer*, which see.

Slab. 2, figs. 3525-7. See *Wash-stand slab*.

Slanting table-leg. Fig. 679. One which abuts against a *slanting table-leg plate* in the side of the car instead of standing vertically, as in fig. 678.

Slanting table-leg hook. Fig. 4291. See above.

Slat. A narrow piece of board or timber, such as *seat-back slats*, *seat-slats*, *window-blind slats*, which see.

Slat cattle-car. A *stock-car*, which see.

Slatted-floor. 27s, figs. 283-6. An open-floor made of slats nailed to cross-pieces with a space left between them so that air can circulate beneath and through between the slats.

Slat-seat. A seat composed of narrow strips of wood. These are usually placed longitudinally on the seats with a space between them.

Sleeper. 1. The ties or cross-timbers on which the rails of a tramway are laid and spiked.

2. A misnomer for a *sleeping-car*, since it is the passengers who sleep and not the car.

Sleeping-car. Figs. 123-31, 176-7, 185-7, 2408-18. *Framing*, figs. 512-30. A car provided with sleeping-berths or beds for the use of passengers at night, which make up by day into ordinary seats, as shown in fig. 2410. The greater number of the sleeping-cars are operated by the Pullman Palace Car Co., and are hence often referred to simply as *Pullman cars*. The Wagner Palace Car Company have a great many cars in service on the Vanderbilt system and allied lines. The Mann boudoir car, which see, is an American invention re-introduced

from Europe, but there are only a small number in service in the United States. *Emigrant sleeping-cars*, figs. 505-11, which see, have recently been introduced, resembling ordinary sleeping-cars, but without upholstery.

The first sleeping-car built in the United States was made in the shops of the Terre Haute, Alton & St. Louis Railroad by a mechanic named Woodruff. The coach provided seats for sixty passengers which were convertible into flat berths. The patent was secured in 1856-7. The next sleepers were two of the same kind run on the New York Central Railroad. Webster Wagner, founder of the Wagner Palace Car Co. built and patented four sleepers for the New York Central Railroad in 1858. The modern palace sleeping-car was introduced by George M. Pullman, who built his first car in 1859. Some of the early Pullman cars had sixteen wheels instead of twelve. The first Wagner palace-car was built in 1867. Both Wagner and Pullman paid royalties to Woodruff.

See *Sleeping-car section. Lower-berth. Upper-berth*.

Sleeping-car furnishings. Figs. 4143-4271. See *Car-furnishings*.

Sleeping-car section. The space in a sleeping-car occupied by two double seats in day-time and by two berths or beds at night. Fig. 2408 shows a recent design of a *sleeping-car section*, many of which are in service, but figs. 2409-12 show the latest or "Columbian 1893" style. See note to fig. 2408. There are usually 10 sections, but sometimes 8 or 12 in a car, in addition to a state-room, smoking compartment, etc.

Sleeve. See *Piston-sleeve. Stake-sleeve*.

Sleeve. 1. (Of car-door lock.) The part connecting the knob to the shank.

2. Sleeve for adjustable brake-head. Figs. 1620-1. See *Self-adjusting spring brake-head*.

Slewing-gear. 1. (For swinging-platform of pile-driver car.) 48 and 49, figs. 401-4. The means for causing the swinging platform to revolve. It consists of a *hand-wheel* and *spur-wheel*, the latter engaging in the *slewing-rack* fixed to the floor of the car.

2. (Of a crane or derrick.) 18, figs. 389-93.

Slewing-rack (of pile-driver car). 50, figs. 401-4. See above.

Slewing-rings (of a derrick). Rings attached to the upper end of the boom for attaching a rope by which to move or steady it when loaded.

Slide-valve (Westinghouse triple-valve). 3, figs. 1706-7. A D-valve controlled in its motion by the piston, by means of which the air is admitted to, and exhausted from, the brake-cylinder, applying and releasing the brake. See also *Reversing-valve*.

Sliding-bolt (of a padlock). B, figs. 2771-2. The bolt in the interior of the padlock which engages with the *shackle*, locking it to place. The forward end of the bolt is termed the *bit*. The movement of the sliding-bolt is controlled by the *sliding-bolt spring*.

Slide-bottom gondola. Figs. 321-4. A gondola-car with the *Center* and *Intermediate* sills separated and a *Slide door* inserted between. The door is moved by a lever, winding shaft and chain, shown and described in the figures. The side framing is an improvement, the anchorages being directly at the ends of the boards. The advantages claimed for the *Sliding doors* is that car may be used for transportation of lumber and other freight, and that it possesses a dumping device without sacrificing any of the essential parts or features of the underframe; that the cost is less, and the doors more secure.

Sliding-door. A door opened by sliding sideways instead of swinging on hinges. Such doors are almost universally used on freight-cars. They are hung by a hook called the *door-hanger*, which slides on a top door-track. See also *Car-door hanger*. They are also in general use on baggage-cars and street-cars. See figs. 1792-3, 2843-5, 5654-67 and 5665.

Sliding-door bracket. A *door-track bracket*, which see.

Sliding-door fixtures. Figs. 2825-51, 1794-1935. See also *Car-door hanger, sliding-door lock and latch*.

Sliding-door friction-roller. Figs. 2846-51. A small wheel attached to the top or bottom of a sliding-door to

- make it run easily. It may or may not carry the weight of the door.
- Sliding door-handles.** Figs. 2582-5. See *Door-handles*.
- Sliding-door hasp and staple (mail-car).** Figs. 2554-5. See *Hasp* and *staple*.
- Sliding-door holder or hook (street-cars).** 142, figs. 5654-67. A metal hook by which a sliding-door can be fastened on the inside.
- Sliding door hook and button (baggage-car).** Figs. 2556-7.
- Sliding-door latch.** Figs. 2554-78. A latch made with a hook lifting vertically instead of a bolt sliding horizontally, for fastening sliding-doors.
- Sliding-door latch-keeper.** Figs. 2558, 2567-8, etc., also called a *strike-plate*.
- Sliding-door lock.** Figs. 2566, 2574-8. A lock made especially for fastening sliding-doors. Such locks usually have a hook which engages in a corresponding catch attached to the door-post. The hook is secured in connection with the catch by means of a bolt which is operated by a key.
- Sliding-door roller.** Figs. 2846-51, 144, figs. 5656-67.
- Sliding-door sheave (street-cars).** See *Door-sheave*.
- Sliding-door track.** See *Door-track*.
- Sliding foot-plate.** 169, fig. 2301. See *foot-plate* and *threshold-plate*.
- Slide-valve spring.** (Air-brake, triple valve.) 6, figs. 1706-7.
- Slip lamp-burner.** Fig. 3370. A burner in which the chimney is held in place by springs or screws, and so constructed that the entire slotted cap to the burner may be removed at once by lifting, still carrying the chimney, without removing any spring.
- Slip lamp-chimney.** Figs. 3422. A chimney with cylindrical base, held in place by lateral springs, so as to be removable by lifting only. Similar to a *sun chimney* which see, but smaller at the base.
- Sloping closet-hopper.** Fig. 3864. See *Closet-hopper*.
- Slow-motion gear (of a derrick or crane).** A system of gearing, intended to be used or not at will by means of a *shifting-pinion*, to decrease the speed and increase the power of the hoisting-gear. Called also *intermediate gear*.
- Small equalizing-guide (Janney-Miller coupler, which see).** See also *Equalizing-guide*.
- Small main-valve piston-head (air-pump).** 79, figs. 1691-2.
- Smillie car-coupler.** Figs. 2199-2201.
- Smoking-compartment furnishings.** Figs. 4273-85.
- Smoke-bell.** 13, figs. 3261-3317; 3444-53. A cover or screen of glass, porcelain or metal, shaped somewhat like a bell, and placed over a lamp to protect the ceiling of a car or room. Large smoke-bells are often called *canopies*.
- Smoke-bell bracket.** Figs. 3451. A separate carrier for a smoke-bell.
- Smoke-bell stem (of lamps).** A tube attached to the upper part of a smoke-bell and serving to conduct away the gases so as to bring the smoke-bell lower and nearer to the lamp.
- Smoke-flue.** A *Smoke-pipe*.
- Smoke-flue base (Baker heater).** Figs. 2287, etc.
- Smoke-jack.** See *Lamp-jack*. *Stove-pipe jack*.
- Smoke-pipe (heaters).** Figs. 2904, etc. The pipe by which the smoke is conducted to the outside of the car, usually called *stove-pipe*, but the stove-pipe of heaters is called a smoke-pipe or *smoke-flue* to distinguish it from the air-pipes.
- Smoke-pipe cap.** Figs. 3058-60. A covering on top of the smoke-pipe to exclude rain and wind. Also called *iack*.
- Smoke-pipe heater (of street-cars).** Fig. 2919a, etc. See a smoke-pipe, through which air is admitted from the top and is thus warmed. See also *Perforated smoke-pipe casing*.
- Smoke-screen (Baker heaters).** Fig. 2877, etc. A conical shaped box, the front of which is the *feed door* and the bottom of which is the hole through which the coal enters the *fire-pot*, and which is covered by the *safety-plate*.
- Smoke-top (Baker heater).** Fig. 2919b, etc. The upper part of the heater, made of Russia iron, in a conical form. A *base of Smoke-flue*.
- Smoking-car.** A car usually attached to all passenger trains immediately behind the baggage-car, in which smoking is permitted; also, in general custom, the only one open to passengers with second-class tickets. *Buffet smoking-cars*, which see, and some others, are more luxurious. Wrongfully called a *Smoker*, as if it did the smoking.
- Smoking-carriage (English).** A passenger vehicle in which smoking is allowed. The whole of a vehicle is seldom devoted to this purpose, separate compartments of each class being set apart for smoking in every train, as required by law. See also *Carriage*.
- Smoking-chair (parlor-cars).** Fig. 3991. A chair distinguished from other parlor-car chairs chiefly in being less roomy and comfortable.
- Smoking-room (sleeping-cars).** The right-hand half of fig. 540. A compartment now almost universal in modern sleeping-cars and parlor-cars. It is generally kept for the free use of the passengers, and separate seats or berths are not sold in it.
- Smoking-room furnishings.** Figs. 4273-85.
- Smoking-room gate.** Figs. 4273-4. A gate sometimes used to close the entrance to a smoking compartment which is shut off by a portiere and has no door.
- Smudge (English).** The scrapings and cleanings of paint pots collected and used to cover the outer side of the roof-boards as a bed for the *roofing canvas*, which see.
- Snatch-block.** Properly a single block which has an opening (*notch*) in one *cheek* to receive the rope. The snatch-block is usually provided with a *swivel-hook*. The term is also popularly applied to any form of single block provided with a hook, although more properly it applies to only one with an opening at the side for readily inserting or removing the rope.
- Snow-flanger.** A plate of iron or steel attached to a car or engine to scrape away snow and ice on the sides of the heads of the rails so as to make room for the flanges of the wheels. The term is sometimes applied to an adjustable plow fitted to a locomotive or car which extends low down onto the track and has a plate or tool for cutting and scraping the snow and ice from the rail. See figs. 414-18.
- Snow-plow.** Figs. 222-5, 408-18. "A machine operated like a plow, but on a larger scale, for clearing away the snow from railroads."—*Hebster*. The parts of a snow-plow corresponding with the plow-share and mold-board of an ordinary plow are mounted on running-gear similar to that used for freight cars. Small snow-plows are also attached to the cow-catchers of locomotives and regularly carried throughout the winter. See *Russell snow-plow* and *Portland Company's snow-plow*.
- Other machines, called the *rotary steam snow-shovel*, fig. 228, and the *full centrifugal snow excavator*, figs. 226-7, operated in a manner altogether different from ordinary snow-plows, are made and are in use on roads in mountainous districts where the snow fall is very great. They have found considerable favor in the Western States. The *Rotary steam snow-shovel* is a powerful machine, carried in a heavy frame, made of steel I and channel beams. A boiler and double cylinder engine of the locomotive type are carried, which are connected by heavy steel pinions to a bevel gear on a horizontal shaft.
- Upon this shaft is mounted the Rotary wheel, consisting of a series of 12 rotary shovels with automatic reversible cutting blades. This is rotated in a drum, or casing, having a square front which cuts the snow not reached by the knives to a width of 10 feet 6 inches or more if required.
- The cutting blades slice the snow from the bank into the shovels, which, with the centrifugal force of the wheel, discharge the snow in a solid stream through a chute on top of the drum to either side of the track desired, and to a distance of from one to two hundred feet. The speed of the wheel is from one to two hundred revolutions per minute. This machine is equipped with

an ice-plow and flanger—the former to protect it from derailment by snow and ice—the latter, for cleaning the flange and rail every time it passes over the road. Coal and water for the Rotary are carried in an ordinary locomotive tender, coupled to the Rotary for this purpose. One Standard locomotive is required to push this machine in any kind of snow.

The "Rotary" has been in successful operation for 10 years and between 50 and 60 of the machines are in service at the present time.

The *full centrifugal snow excavator* has a "scoop" in front, 10 feet or more wide and 11 feet high, consisting of a square-shaped open front box, within which revolves the "snow cutter." The "snow cutter" consists of an inverted truncated cone, inclined downward and laterally upon which are riveted four helical, sharp edged cutting blades, which slice off the snow, gather it into the "scoop" and, by centrifugal force, discharge it to either side of the track separately, or to both sides at once, through openings in the "scoop." The diameter of the cone from the outer edge of one cutting blade to that of its opposite blade is, at the large or upper end 10 feet, at the small or lower end 3 feet. The "snow cutter" is operated by an engine of locomotive design, having two cylinders, 18-inch diameter 24-inch stroke. The excavator is equipped with separate flanger and ice cutters, which are controlled and operated by the pilot by means of compressed air, and it is equipped with Westinghouse air-brake. Two hundred revolutions of the "snow cutter" are made to 175 revolutions of the engine. In actual service, the number of revolutions of the "snow cutter" varies from 150 to 250 revolutions per minute according to the difficulty of the work to be done. Eleven of these machines are now in service.

Snow-scraper. A plate or bar of iron or steel attached to an engine or car to scrape away the snow and ice from the rails.

Snow's boltless steel-tired car-wheel. Figs. 5321-9. One of the many forms of steel-tired car-wheels in use. The tire is prevented from crowding in toward the center of the axle by a heavy cast-steel lip on the tire, which engages in the cast center, and the tire is held in place against this lip or lug by a retaining-ring somewhat of the Gibson form, and shown in figs. 5322-4 and 5329. The other parts of the wheel are the tire with its *internal flange*, or lip, the retaining-ring and the cast-iron center.

Soap-dish. Figs. 3502-7; 6, figs. 3468.

Soap-holder. A soap-dish attached to a partition like a bracket.

Socket. "Any hollow thing or place which receives and holds something else."—*Webster*. As the socket for water-cooler valve.

See also *Berth-curtain rod* *Revolving-chair stand*
bushing, or socket. *socket.*
Flag-holder socket.

Socket-caster. Fig. 4114. A fixed or rigid caster. Not properly a caster at all, except by custom of the trade. See *Caster*.

Socket-washer. Fig. 3722. A large washer with a cavity to receive the head or nut of a bolt or rod so that it will not project beyond the surface of the wood to which it is attached. Also called *cup-washer*.

Sofa (sleeping-cars). A longitudinal seat which makes up by pulling out sidewise so as to drop the back. Now used only in staterooms.

Sofa arm-rest bolt. Figs. 4128-9.

Sofa arm-rest fixtures. Figs. 4116-23.

Sofa-back (Mann boudoir cars). B, figs. 2418. The part which makes the upper berth.

Sofa-back pivot-hinge and plate. Figs. 4124-5.

Sofa back-leg socket. Fig. 4130.

Sofa bed-hinge and socket. Figs. 4131-5.

Sofa-bed support. Fig. 4136.

Sofa-bolt (sleeping-cars). Figs. 4138-9. A sliding bolt used for holding a sofa in its place. It is operated from the front by a *sofa-pull* working through a *sofa-crank*, fig. 4138. Sofas standing against the side of the cars are now little used, except in private cars.

Sofa-caster. Fig. 4112-5. See *Caster*.

Sofa-furnishings. Figs. 4116-4140.

Sofa-hinge. Figs. 4126-7. A hinge by which the seat and back of a sofa are fastened together so that they can be changed from a sofa into a bed. See *Seat-hinge*.

Sofa leg-hook. Fig. 4140.

Sofa rail-end and socket. Figs. 4131-3.

Sofa-spring (English). See *Seat sofa-spring*. *Back-squab sofa-spring*.

Soffit-board. 121s, figs. 539-41. A board which forms the under side or ceiling of some subordinate part or mem-

ber of a building or a car, as of a staircase or cornice. See *Deck soffit-board*.

Soil-hopper. Figs. 3855, etc. See *Closet-hopper*.

Sole-bar (English). 1, figs. 348-51; 501-4. American equivalent, *side sill*. One of two longitudinal bars which are the main members of the *underframe*, which see. In English car-construction the side sills are relatively more important than in America, as will be seen in figs. 348-51.

Sole-bar angle-iron (English). 12, figs. 501-4. An angle-iron secured to the *sole-bar*, to stiffen it. A plate is sometimes used instead of an angle-iron.

Solid-braided bell-cord. Figs. 2471, etc. See *Bell-cord*.

Solid-head drawbar. Fig. 2073. A wrought-iron drawbar having the head and shank in one solid forging instead of being united by riveting.

Solid-leather nails. Figs. 3643-4. A form of ornamental nail for finishing work, in which the head is of solid leather, the mode of attaching the metal pin to the same having been patented Oct. 18, 1881. The same principle is applied to the manufacture of *solid-leather buttons*, also much used for decorative purposes.

Solid wrought-iron single-spoke wheel. Figs. 5274-5, 5278-9, 5292-3. A wheel in which the spokes, hub (*boss*) and rim are all welded together, each spoke consisting of one single bar. The tire is shrunk on.

Spacing-block. See *Body-bolster spacing-block*.

Spanner. Fig. 1725. A wrench for uncoupling hose, etc., formed like the arc of a circle, with notches or lugs for engaging into dogs or grooves on a spanner-nut.

An ordinary wrench is termed a *spanner* in England. **Spanner-nut (Eames ejector).** 10, figs. 1663-4. A nut with many sides like a hose-coupling, so as to approximate more closely to a circular form, and commonly provided with lugs or vertical grooves cut in its circumference for engaging with a *spanner*. The *piston-rod packing-nuts* of Westinghouse air-pump are of this pattern.

Spear anti-clinker car-heaters. Heaters or stoves manufactured by Mr. James Spear, of Philadelphia, for heating cars, and made with a sheet-iron outside casing which leaves an air-space between the stove and casing, into which a current of air is admitted, and is warmed by coming in contact with the stove, and then escapes into the car. Several different patterns are made. In fig. 3058 the cold air is admitted through a hood on top of the car, is carried down to the bottom of the stove by a pipe, and then circulates around the pipe, as shown by the arrows, and enters the car through a hot-air pipe which extends the whole length of the car, with registers at each seat. In fig. 3060 the hot-air pipe is not used, the warmed air escaping directly into the car through openings in the base and top of the stove. In this pattern an independent cold-air pipe is not used, but the smoke-pipe is enclosed in a casing, with a space between the two, through which the cold air descends and passes over the stove and escapes, as shown by the arrows.

The "anti-clinker" feature of these heaters consists in a peculiarly arranged grate, shown in the section, fig. 3059, with an annular opening between it and the base of the stove, through which the clinkers can be removed from the grate.

Spear's caboose stove and details. Figs. 3073-3105. A favorite stove for caboose-cars.

Spear's draft-regulator. A device by which an air inlet is opened in the smoke-pipe in such manner that the draft is checked, but no gas is permitted to escape, the current being entirely inward.

Specifications, cast-iron wheels. See *Wheels, specifications for cast-iron wheels*.

Spider. See *Center brake-lever spider*. *Tank waste-cock spider*.

Spider-plate, or underframe plate (English). 16, figs.

348-51 and 501-4. A flat horizontal wrought-iron bar connecting two or more timbers of the *underframe* together, and being placed beneath them prevents one sinking below the others. It is often made with three or more arms radiating from a common center; hence its name. The form shown is a plainer form.

Spindle. Figs. 2631, 2639-41. See *Door-latch spindle*.

Spindle, or bolt drawbar. Figs. 2073-4, 2100-1. See *Drawbar*.

Spiral-elliptic seat-spring. Figs. 4001-2. A spring made of a thin band of steel wound in a spiral coil, the transverse section of which is elliptical.

Spiral sash-spring. See *Sash-spring*.

Spiral seat-spring. Figs. 4009-13. The common form of seat-spring, which see.

Spiral spring. Figs. 5192-5228, 5235-40a. A spring made of a metal rod or bar coiled in the form of the thread of a screw so that it can be compressed or expanded in the direction of the axis around which it is coiled. Most of the springs now in use in car-work, except the bolster-springs of passenger-cars, are spiral springs. *Volute* springs, *india-rubber* springs, *compound* or *wool-packed* springs, are quite obsolete. Spiral springs are designated as *single*, *double*, *triple*, or *quadruple-coil* springs when nested one inside the other. Such springs are also called *nest-springs*. Usually, the single springs or nest-springs are again combined into *two-group*, *four-group*, *six-group*, etc., springs. Two to eight-group springs are the most common. *Graduated-springs*, figs. 5218-20, seem to have had their day and are not often specified for new construction. The various springs in them come into action successively as the load increases instead of all at once. Spiral springs are also designated according to the section of bar as *round-bar*, *flat-bar*, *square-bar*, *half-round bar*, *oval-bar*, *edge-rolled*, etc., but nearly all springs are now made from round-bar steel. *Equal-bar* is a term applied to nest-springs made from bars of such size that the resistance of the coil is proportioned to its diameter. Spiral springs are also designated according to their use as *equalizer-springs*, *journal-springs*, *pedestal-springs*, *bolster-springs* (which latter are the main springs of a car), *buffer-springs*, *draft-springs*, etc.

Spiral-spring cap. 75, figs. 4742-5; figs. 5193-5222. A casting or plate which forms a bearing for the top of a spiral spring, and which also holds it in its place. A seat is used at the other end, but both these parts in bolster-springs are commonly called *spring-plates*, which see.

Spiral-spring seat. 74, figs. 4742-5. See above.

Spittoon. Fig. 2858, etc. A vessel to receive discharges of spittle and other abominations. A *cuspidor*, which see, is the same thing in a different form.

Splash-board. A board attached in an inclined position covering up the back of passenger-car steps. It serves much the same purpose as the *risers* of steps, and prevents mud and dirt being thrown on the steps. Not in general use.

Splasher (English). 188, figs. 501-4. An iron plate attached to the floor above the wheels. Only used when the wheels are too large in diameter to clear the ordinary floor. Also called *wheel-cover* or *wheel-plate*.

Splice. 1. "The union of ropes by interweaving the strands."—*Webster*. Hence any appliance by which the ends of a rope, cord, beam or bar, are united. See *Bell-cord splice*.

2. (For car-sills.) See *Scarf-joint*. *Ship-splice*. According to the rules for the interchange of cars of the Master Car Builders' Association, the splice of a sill to be received must be 24 in. long. See *Interchange of Traffic*.

Split-key. A form of pin which is self-fastening, consisting essentially of two parallel strips or bars of metal, which, when united, constitute one pin, but which tend to separate and be withdrawn

Split-ring (for lamp). Figs. 3333-6. An adjustable ring to carry a lamp or lamp-shade, permitting of a variation of diameter.

Spoke. "One of the radial arms which connect the hub with the rim of a wheel."—*Knight*.

Spoke-wheel. Figs. 5257-8, 5261-4, etc. A wheel, the rim or tire of which is connected with the hub by spokes instead of one or more plates. These spokes are sometimes made of solid cast-iron, in others they are cast hollow, and in still others are made of wrought-iron. See *Hollow-spoke wheel*, fig. 5332. *Hand-car wheels*, figs. 5620-31. *Wrought-iron* (Kirtley's double-spoke) *wheel*, figs. 5289-1, etc., and *Solid wrought-iron spoke-wheel*, figs. 5292-3, etc.

Spool (of hoisting-gear). 41, fig. 402. The drums on which the hoisting rope or chain is wound.

Spool-shaped spiral-spring. Fig. 5243. This form was patented by W. P. Hansell in 1874-5. Its object is to obtain a *graduated* spring, which see. Little used.

Spring. Figs. 5192-5254. *Elliptic* springs, figs. 5229-34. An elastic body to resist concussion. Springs are also used to produce motion in a reverse direction to that caused by some other applied force, as a brake-spring and the spring of a door latch. The leading forms of springs are *elliptic-springs* and *spiral springs*, which see. Modifications are the *spiral-elliptic* and the *half-elliptic* springs. *Volute* and *india-rubber*, or *gum* springs are little used. Spiral springs are designated according to the number combined together one within the other, as *double-coil*, *triple-coil*, etc., or if the springs are placed side by side, as *two-group*, *four-group*, *six-group*, etc.; elliptic springs, according to the number united to work together as one spring, are designated as *double* or *duplicate*, *triple* or *triplicate*, *quadruple*, *quintuple*, and *six-tuple*. The main springs about a car are nearly all spiral springs, except that elliptic springs are almost exclusively used for the bolster-springs of passenger-cars. The minor springs, designated in name by the purpose which they serve, are the following, which see:

<i>Back-spring.</i>	<i>Lateral-motion spring.</i>
<i>Berth-spring.</i>	<i>Mirror-frame spring.</i>
<i>Brake-hose coupling-valve spring.</i>	<i>Release-spring.</i>
<i>Candle-spring.</i>	<i>Safety-grate spring.</i>
<i>Coupling-spring.</i>	<i>Sash-spring.</i>
<i>Double release-spring.</i>	<i>Sash-lock spring.</i>
<i>Double sash-spring.</i>	<i>Seat-latch spring.</i>
<i>Door-latch spring.</i>	<i>Seat-lock spring.</i>
<i>Door-lock-bolt spring.</i>	<i>Seat-spring.</i>
<i>Door-spring.</i>	<i>Spiral seat-spring.</i>
<i>Graduating spring.</i>	<i>Spiral sash-spring.</i>
<i>Journal-box-cover-spring.</i>	<i>Swing-bolster spring.</i>
	<i>Window-blind spring.</i>

The principal springs of a car supporting its weight are the *bolster-springs*, also called *bearing-springs* or *body-springs*. *Equalizing-bar* or *equalizer* springs are used in addition on passenger-cars, as also sometimes *journal* springs. *Side journal-springs* are used on street-cars and are sometimes *keg-shaped* or *spool-shaped*, which see. Tension is communicated through the *draw-spring*. A separate *buffer-spring* or *auxiliary buffer-spring*, which see, is sometimes used. See also *Set of springs*.

In European practice *bearing-springs* are semi-elliptical; *buffing* and *draft-springs* are rubber, semi-elliptical spiral or volute. The seat-cushions and backs are supported by *sofa-springs*. The tendency to-day of American practice is toward single and double coil round-bar springs, for car work. The use of 7, 8, 9, etc., coil bolster springs is rare and the great majority of bolster-springs used under new freight-cars are the three and four coil-springs shown in figs. 5199-5205 and 5207-12. A recent adoption is that shown in figs. 5192-8, where plain single-coil springs are bought and these put under a car, the number being in proportion to the capacity of the car. For equalizer-springs the universal practice is to use plain single and double-coil round-bar spiral spring.

- Spring-band** (elliptic-springs). 1, figs. 5230. A wrought-iron strap which embraces the plates at the center.
- Spring-beam** (six-wheel trucks). 42, figs. 4957-66. A transverse timber which rests on top of the bolster-springs. There are two such to each truck, on which the *bolster-bridges*, which support the *bolster*, rest. It is sometimes of iron, as **B**, figs. 1971-73.
- Spring-block**. 74, fig. 4580. A piece of wood used as a distance-piece above or below a spring.
- Spring-blocks**. Figs. 4976-8. Blocks to which the *equalizer spring-caps* are attached. They are made right and left.
- Spring-box** (Westinghouse pump governor, which see). 38, fig. 1716.
- Spring-burner**. Figs. 3370, etc. A lamp-burner to which the chimney is fastened by a spring.
- Spring-cap**. A cup-shaped piece of cast or wrought iron for holding the top of a spring and against which the latter bears. They are further distinguished by the name of the spring, as *bolster-spring cap*, etc. The *spring-seat* comes below the spring, but both these parts are very commonly called *spring-plates*, especially in large *group-springs*.
- Spring-case**. A cast-iron box made in two parts to hold one or more spiral or india-rubber springs. Such springs are nearly obsolete.
- Spring door-latch**. Figs. 2706, 2731-3. A latch, the bolt of which is thrown into contact with a catch by a spring and is disengaged by a knob or handle. Such latches are not arranged so as to be fastened with a key. See *Latch*.
- Spring door-lock**. Figs. 2714-25. A lock usually called a *night-latch*. See *Latch*.
- Spring door-stop**. Figs. 2803-6. See *Door-stop*.
- Spring draw-clevis** (street-cars). One which can slide longitudinally, and whose movement is resisted by a spring.
- Spring draw-hook** (street-cars). One which can slide longitudinally, and whose movement is resisted by a spring, so as to give it elasticity when subjected to tension.
- Spring-edge** (car upholstery). Figs. 3905, 3929-32, 3961, etc. A term applied to a method of upholstery which protects the frame-work entirely by springs, so that it is not felt by the occupant of the seat.
- Spring end-sill**. A long bar of some tough, elastic wood used in certain narrow-gage and other cheap cars as a substitute for a draft-spring. It is bolted to the end-sills at its ends only, and having a cast-iron draw-head bolted to its middle. The natural spring of the wood then becomes a partial and cheaper substitute for a draft-spring.
- Spring-hanger**. 1. (Elliptic springs.) 170, fig. 385. A T-shaped bolt or an 8 or U-shaped iron strap which sustains the end of a semi-elliptic spring. The *T-hanger* is a bolt with a T-head passing through a *slot* in the spring, used in locomotives, but not on cars. The 8-shaped hanger is a wrought forging with holes at each end for two bolts, fig. 385.
2. (English.) See *Scroll-iron*. *End scroll-iron*. *Spring-link*.
- Spring-hanger iron or bracket** (caboose, etc.). 171, fig. 385. A bent bar fastened to a pedestal timber or wheel-piece, to which the spring-hangers are attached.
- Spring-hinge**. Figs. 2617-20. See *Double-acting spring-hinge*.
- Spring-link, or spring-shackle** (English). 84, fig. 501. American equivalent, *spring-hanger*, a term also used in England. A link attached to the end of a laminated spring by which the weight is placed upon it.
- Spring-link adjusting-screw, or tee-bolt** (English). 85, fig. 501. An eye-bolt by which the tension of the bearing-spring, and, to some extent, the height of the car-body above the rails can be regulated. Rarely used except in passenger service, where it is very general. A different style, having the bolt vertical, shown at 86, fig. 501, is the same as above, except that being vertical, it cannot put initial tension on the spring.
- Spring-padlock**. Figs. 2768-72. A padlock, the hasp of which can be locked by pressure only, without a key; so called in distinction from a *dead padlock*.
- Spring-pin**. 41, figs. 4822-4966. See *Lateral motion spring-pin* (passenger-car trucks).
- Spring-pivot** (deck-sash, which see). Fig. 4580-4966.
- Spring-plank**. 43, fig. 4580-4966. A transverse timber underneath a truck-bolster and on which the bolster-springs rest. Also called *sand-plank* or *sand-board*. A *spring-plank safety-strap* or *guard*, which see, passes under the spring-plank. In iron trucks, iron *spring-plank bars* take the place of the wooden spring-plank, and in other trucks they are very common. A *swing spring-plank* is used in passenger and other *swing-motion* trucks (which see). In rigid-bolster the spring-plank is bolted to the lower arch-bar of the truck-frame. Some exceptional forms of trucks, as figs. 4753-7, have no spring-plank nor bolster-springs.
- Spring-plank bars** (iron 6-wheel truck). See above.
- Spring-plank bearing**. 44, figs. 4580-4966. A casting on which a spring-plank rests, and which is supported by the lower swing-hanger pivot. Also called *cross-bar casting* or *spring-plank carrier*, figs. 2110-11.
- Spring-plank fitch-plates** (passenger truck). Figs. 4825-6. See *Fitch-plate*.
- Spring-plank safety-strap** (passenger-car trucks). 45, figs. 4842-4966. A U-shaped strap of iron attached to the transoms, and passing under the spring-plank, so as to hold it up in case the swing-hangers or their attachments should break.
- Spring-plank timber** (framed spring-plank). A timber forming one of the sides.
- Spring-plate**. Figs. 4710-15, etc. A common term for *spring-seats* and *caps*, especially those of considerable size, as for bolster springs. They are often provided with *spring-plate lugs* to hold the spring in place.
- Spring-plate lugs** (bolster-spring). Shown in figs. 5208-18b. See above.
- Spring-pocket** (strap drawbar). See below.
- Spring-pocket or strap, drawbar**. Figs. 1976-2019. A drawbar with a rectangular strap or "pocket," figs. 2005-6, at the back end in which the draft-spring is placed. So called in distinction from a *bolt* or *spindle-drawbar*, fig. 2100.
- Spring-saddle**. 1. (Iron passenger-car trucks.) A \cap -shaped bar of wrought-iron, which is placed on top of a journal-box surrounding the arch bar and on which a spring rests.
2. (Street cars.) Fig. 5650. A similar part having projecting ledges (*spring-shelf*) on each side, on which the springs rest.
- Spring-seat**. 74, figs. 4580-4966. A cup-shaped piece of cast or wrought iron on which the bottom of a spring rests. See *Spring-cap*. *Spring-plate*.
They are further distinguished by the name of the spring for which they serve, as *bolster-spring seat*, *equalizer-spring seat*, etc.
- Spring-shackle** (English). See *Spring-link*.
- Spring-shelf**. See *Spring-saddle*.
- Spring-stud** (street-cars). A round iron bar which rests on the top of the journal-box or spring-seat and passes through the center of a spiral or rubber-spring. The upper end works in a guide and thus holds the spring in its place. A similar bar has been used on steam-cars for transmitting the weight from the spring to the journal-box.
- Spring-yoke**. A *spring-saddle*, which see.
- Sprue** (foundry). The piece of metal which fills the *gate* or channel through which the metal is poured in making

a casting. This piece is broken off when the casting is cooled. The gate itself is often called a sprue.

Sprue-hole. A *gate* of a mold for casting metals.

Spud. Figs. 3478-9. A bushing or coupling by which the hole of a sink or water cooler drip are connected with the drain or drain-pipe.

Spur-wheel. 1. (Hoisting-gear, etc.) 7, figs. 207, 394-5. Literally any cog-wheel, but usually meaning the larger one of a pair of wheels in gear, in distinction from the *pinion*, which is the smaller one of the two.

2. (Lever hand-car.) 5, figs. 5592-5600.

3. (Slewing-gear of pile-driver car, which see.) 49, figs. 401-4.

Spurr's veneers and wood carvings. Figs. 3660-3. Paneling and decorations in relief, consisting of a *papier-maché* backing covered with a thin shaving of superior wood and pressed in imitation of wood carving.

Squab-cushion. One formed of a bag or case stuffed with curled hair or other elastic material, not attached to the seat, but simply laid upon it. Now little used, *box-cushions* being preferred. See *Cushion*.

Square-bar spiral-spring. See *Spiral spring* and *Spring*.

Square door-bolt. Fig. 2540, etc. A door-bolt made of a square and straight bar of metal. When the bolt has an off-set it is termed a *square-neck door-bolt*, as in fig. 2543.

Square-end. A rectangular piece on the end of a shaft to which a crank or wrench can be applied; also termed *winding-arbor* or *crank-pin*.

Square-lantern. Figs. 3330. A form having glass on three sides, used chiefly for fixed lights.

Square-root iron. A term applied by manufacturers to angle iron in which the corners are brought to a sharp angle and not rounded off. Thus: L. Square-root iron is one form of angle-iron, but is never meant when that term alone is used.

SS-lock (freight car-door). Fig. 2750.

Stake (flat or platform cars). 42, figs. 305-15. A stick of wood attached outside the sills by a *stake-pocket* or *stake-pocket strap*, 39A, figs. 287-9, and *stake-bolt*, which see, to keep the load from falling off. They are sometimes attached by a mere swiveling bolt, so that they can be dropped down horizontally, if desired.

Stake-bolt (gondola and platform cars). A bolt passing through the end of the stakes, serving in connection with the *stake-pocket strap*, which see, in place of the ordinary form of stake-pocket, figs. 914-15.

Stake-hook (platform-cars). A hook on the side of a platform car to hold a swiveling stake in an upright position.

Stake-pocket (gondola and platform cars). 39, figs. 298-315, 908, 914-15. A cast-iron receptacle attached to the side-sills by U-bolts to receive the end of a stake. A substitute is the *stake-pocket strap*, which see.

Stake-pocket strap or U-bolt (gondola, platform and stock cars). A U-shaped bolt flattened at the side, and serving as a substitute for the ordinary form of stake-pocket, when the stakes are intended as permanent attachments.

Stake-pocket U-bolt. A U-bolt applied to a stake-pocket that encloses three sides of the stake and pocket and passes through the flange-holes into the side-sill to which it is bolted.

Stake-rest (flat-cars). 2, fig. 14. A bracket or support on which a stake rests when turned down horizontally.

Stake sleeve (flat or gondola cars). A casting with a horn-shaped projection slipped over a stake to hold up the hinged side of a platform or gondola car.

Stanchion. 1. A prop or support.

2. (Nautical.) A term very generally, but not exclusively, used for posts with an eye in one end which car-

which holds a rod or other object, as a hand-rail or curtain-rod. The opposite end is usually fastened by a nut, or with a flange or lugs which form a part of the stanchion. Also see *Window curtain-rod stanchion*.

Stand. "Something on which a thing rests or is laid."—*Webster*.

See *Radiator-stand*.

Revolving-chair stand.

Seat-stand.

Water-cooler stand.

Standard. 1. Fig. 3185. A name sometimes applied to the *column* or *bolster guide-bar*, which see.

2. (Of M. C. B. Association.) A considerable list of standard details of cars, given separately below and jointly under *Master Car-Builders' Association*, have been adopted. See *Master Car-Builders' Standards*.

In 1893, when the old standards of the Master Car-Builders' Association were divided into two groups; the group which retained the name *standard* was defined as "Those forms, parts, constructions, units, measurements or systems in which it is desirable to secure not only sound construction, good practice, and safe operation, but which also promote quick and cheap repairs and consequent free interchange of cars."

The group termed *Recommended Practice* was defined as "Those forms, parts, constructions, units, measurements or systems which are conducive of sound construction, good practice, and safe operation, but which do not affect either interchangeability of parts or interchangeability of cars as a whole."

Standard axles (M. C. B.). Figs. 5419-20. See *Axle*.

Standard bolts and nuts (table). Figs. 5492-8. See *Sellers standard*.

Standard brake-shaft attachments (M. C. B.). Figs. 5546-7. It is no longer a standard, but it is *Recommended Practice*.

Standard brake-shoe head and key. Figs. 5425-31. A brake-shoe and head of the Christie form, adopted as a standard by the M. C. B. Association in 1886 with the exception of slight modifications in details made in 1888 and 1891. As shown the head is made to fit a wooden brake-beam which are quite out of use. The head is now made for rectangular or round iron brake-beams. The peculiarity of the head and shoe is the use of a dovetailed joint and the fact that the shoe is reversible. The weight of the shoe is about 20 lbs. and of the head about 10 lbs. The shoe is held in position by a *Key*.

Standard buffer-blocks and height of drawbar (M. C. B.). Figs. 5540-2, 5548-51. No longer a standard, but *Recommended Practice*.

Standard car-axle (M. C. B.). Figs. 5419-20. See *Axle*.

Standard car-coupler (freight). Figs. 2202-8; passenger, figs. 2256-66.

Standard check-gage, for mounting wheels (M. C. B.). Fig. 5486. Adopted in 1894. See *Check-gage*.

Standard draft-gear attachments (M. C. B.). Figs. 5507-37. No longer a standard, but *Recommended Practice*. See *Drawbar-attachment*, etc.

Standard dry-closet. Figs. 3857-9. See *Dry-closet*.

Standard gage. The most common distance between the rails of railroads, which is throughout the world 4 ft. 8½ ins. See *Gage*. This gage originated from the use of an even 5 ft. gage with *outside flanges*. As inside flanges came to be preferred, and had to run on the same rails (then with much narrower heads than now) the present standard was of necessity used.

Standard journal-bearings and wedges (M. C. B.). Figs. 5389-5418. See *Journal-bearings*.

Standard journal-boxes (M. C. B.). Figs. 5377-88. See *Journal-boxes*.

Standard ladder and grab-iron attachments (M. C. B.). Figs. 5546-7. No longer a standard, but *Recommended Practice*. See *Hand-holds and Ladders*.

Standard markings for line cars (M. C. B.). Figs. 5543-5. No longer a standard, but *Recommended Practice*. See *Marking line-cars*.

alogy from nau-

eye in one end,

Standard limit-gage (for round iron; M. C. B.). Figs. 5490-1. No longer a standard, but *Recommended Practice*. See *Limit-gage*.

Standard pedestal (M. C. B.). Figs. 5480-3. See *Pedestal*.

Standard screw-threads (M. C. B.). Figs. 5492-8. See also *Sellers* and *Whitworth*. See *Screw-threads*.

Standard splice (M. C. B.). See *Interchange of Traffic*.

Standard wheel gage (*between backs of flanges*; M. C. B.). Fig. 5421. See *Wheel-gage*.

Standing, immediate or partition pillar (English). 95, figs. 501-4. American equivalent, *post*. An upright piece in the body running its entire height. The term is not applied to the *corner* or *doorway pillars*, which see.

Staple. A U-shaped piece of wrought-iron pointed at the ends, to be driven into wood to hold a hasp, hook, pin, etc. The term is also applied to a wrought or cast-iron keeper which is screwed or bolted to the door-post or frame and over which a hasp fits.

Star-ventilator. Fig. 4311. See *Ventilators*.

Stasch-ventilator. Fig. 4310. See *Ventilators*.

Stationary-lock (freight-cars). Figs. 2736-59. A lock permanently fixed to the door or side of the car, in distinction from padlocks, which are quite out of use on freight-cars.

Stay. A beam, bar, rod, etc., by which two or more objects are connected together to prevent lateral deviation of one or both of them.

See *Body queen-post stay*.
Center-stay.
Lamp-stay.

Pipe-stay.
Sill-step stay.

Stay-rod. 1. A rod which acts as a stay. See *Pedestal stay-rod*, 7, figs. 4842-4966.

2. (Of a derrick or crane.) See *Tension-rods*.

Steam-car. A term used to designate ordinary railroad cars when it is desired to distinguish them from *street-cars*.

Steam-cylinder (air-pump). 3, fig. 1689; 61, figs. 1691-2; 1-2, fig. 1752. The admission of steam to this cylinder is controlled by the *reversing-piston* and *reversing-valve*, which operate the *main steam-valves*. See *Cylinder*.

Steam-cylinder gasket (*upper* and *lower*, of air-pump, etc.). 36 and 37, fig. 1689; 101-2, figs. 1691-2. See *Gasket*.

Steam-cylinder head (Westinghouse brake). 2, fig. 1689; 60, figs. 1691-2. A cover for the top of the steam-cylinder.

Steam jacket. Figs. 3039-45, etc. See *Jacket*.

Steam-jet (Gold's car-heating). Fig. 3008; M, fig. 3006 and F, fig. 3003. See *Double-coil steam-jet system*.

Steam-pipe. 1. (Air-pump, steam-heating pipe, etc.) 54, fig. 1689. The steam supply-pipe to the steam-cylinder.

2. (Westinghouse pump-governor.) 59, fig. 1716.

Steam-pipe union (air-pump). 14, fig. 1689, etc. A *pipe-coupling*, which is often called a *union*.

Steam-piston (air-pump). 10, fig. 1689; 65, figs. 1691-2. See *Piston*.

Steam-piston packing ring (Westinghouse air-pump). 12, fig. 1689; 67, figs. 1691-2. See *Piston*.

Steam-valve, or *main steam-valve* (air-pump). Figs. 1689-92. A peculiar device for controlling the admission of steam to the steam-cylinder of the engines and air-pump, by means of the *reversing-piston*, which see, working in the *reversing-cylinder*. The *upper* and *lower* steam-valves are of different diameters and connected by a fixed rod. See *Main steam-valve*.

Steam-valve bushing (air-pump). See above and *upper and lower steam-valve bushing*.

Steam wrecking-car. See *Derrick-car* and *Wrecking-car*.

Steel Motor Company's electric-motor (for street-cars). Fig. 5679.

Steel-tired wheel. Figs. 5225-5334. A wheel with a steel tire. In the *McKee Fuller* and *Washburn* wheels, which see, the tire is welded to the body or center of the wheel,

which is made of cast-iron. The term, unless otherwise stated, however, always means that the tire is shrunk on, bolted or fastened with *retaining-rings*.

Steel-tired or iron-tired wheels have been long in use in Europe, and are in quite general use in this country for passenger-cars. The report of an M. C. B. Association committee, 1894, estimates the number of wheels in use under passenger-cars as 145,820 and the number of steel-tired wheels at 51,862, or about 36 per cent. The general form shown in figs. 5320 and 5347 is that which English experience has settled on as the best, and it is in almost universal use on English passenger-cars. See *Mansell retaining-ring and tire-fastening*. See also *Allen paper-wheel*, *Arbell-Cockarell*, *Boies*, *Brunswick*, *Krupp*, *McKee-Fuller*, *Paige*, *Taylor*, *Teakwood*, *Vauclain*, *Snow's-boltless*, *Washburn*, etc.

Steel-tire, minimum thickness. (M. C. B. Recommended Practice.) Fig. 5489. In 1894 a recommended practice was adopted for minimum thickness for steel-tires of car-wheels, to be 1 in., to be measured normal to the tread and radial to the curved portions of the flange through the thinnest part within $4\frac{1}{2}$ inches from the back of the flange; the thickness from the latter point to the outer edge of tread to be not less than $\frac{1}{2}$ in. at thinnest part, as shown in Fig. 5489.

A further practice was adopted of cutting a small groove, as shown in the outer face of all tires when wheels are new, at a radius $\frac{1}{4}$ in. less than that of the tread of tire when worn to the prescribed limit, to facilitate inspection.

Steel-wheel. Figs. 5316-19. A wheel which is made wholly of cast-steel. Quite a number of *Taylor's manganese steel-wheels* have been introduced lately and are in service, but *steel-wheels* are not common.

Stem. See *Buffer-stem*. *Graduating-stem*. *Reversing-valve stem*. *Smoke-bell stem*. The rod to which a valve of any kind is attached is always called a *stem*.

Stem (snow-plow framing). 16, figs. 410-3.

Step. 1. A ledge on a stair or round or rung of a ladder.

2. A foot-piece for ascending to or descending from a car or for standing in certain places or positions. *Passenger-car steps*, figs. 2419-45, are from their locality called *platform-steps*, or from their material *box-steps*. On street-cars only a single step is used, called the *side-step*. See also (street-cars) *enclosed-step*, *longitudinal-step* or (English) *foot-board*. In freight-cars a U-shaped iron called the *sill-step*, which see, figs. 897-8, is used, and a kind of platform on the roof, called the *roof-step*. A small ledge on the end of a freight-car near the top for a brakeman to stand on when applying brakes, called the *brake-step*, is also used, but it is not recommended by the Master Car Builders' Association, but it is considered good practice on many roads. A bracket called a *tank-step* is attached to the tanks of tank-cars. Steps in stairs are connected by vertical *risers*.

Step-facings. Figs. 3788-9. A metallic facing for the step-hanger.

Step-fender (street-cars). 75, fig. 5654. See *Fender*.

Step-hanger. 48, figs. 435-73. A vertical wrought-iron bar by which the steps are supported from the corner of a car and from the platform-timber.

Step-iron. 1. (Platform steps.) 47, figs. 435-73. A flat iron bar bent to conform to the shape of the steps and their risers and to which they are fastened. It is bolted at the upper end to the platform-sill.

2. (English.) 173, figs. 501-4. Also called *leg-iron*. A wrought-iron forging attached to the *sole-bar*, and supporting the upper and lower *foot-boards*, which see.

Step-ladder hinge. Fig. 2615.

Step-mouldings or *Nosings*. Figs. 3790-2. A metallic facing or moulding for the tread of steps.

Step-timber. Figs. 1230-1. A timber bolted to the *end-sill* and *platform end-sill* to which the platform-steps are hung.

Step-ladder (sleeping-car). Figs. 4233-6. A folding step-ladder, for use in a sleeping-car, to reach the lamps, upper berths, etc.

Steps, Ladders, etc. (Rules for Interchange of Traffic.) Defects for which cars may be rejected are the following:

(c) Steps, ladders, hand-holds or running boards in bad order or insecurely fastened. Steps, ladders and hand-holds must be fastened by bolts or lag screws. Hand-holds must be of wrought iron or steel.

Step-riser. The vertical portion of a step in stairs.

Sterlingworth body-bolster. Fig. 2033. A body-bolster consisting of an I-beam, turned up its side and filled with wood, to make it rectangular. It is placed upon the side with a view to resisting buffing strains.

Stier dust-guard. Figs. 5155-8. A wood and felt dust-guard made of several pieces, but when finished being in three pieces, viz.:—two halves and a spring, which spring keeps the two halves together and against the axle.

Stevens brake. Fig. 1461. An arrangement of brake-levers by which the pressure is equalized on all wheels. It is practically obsolete in modern cars.

Stile. **S,** fig. 1783-93. The upright pieces on the outer edge of a door or sash, as *door-stile*, *sash-stile*, *window-blind stile*, etc.

Stirrup. 1. A kind of ring or bent bar of iron resembling somewhat the stirrup of a saddle. A drawbar carry-iron is sometimes called a *stirrup*.

2. (Janney coupler.) Shown in figs. 2301 and 2348. A drawbar carry-iron.

3. (Thurmond McKeen coupler and attachments.) Fig. 2281. *McKeen carry-iron*.

Stirrup-block (Miller platform). **30,** figs. 2290-2. A block attached to one of the center-sills next to the platform end-timber, to receive the bolts which hold the *drawbar carry-iron*.

Stock-car. Figs. 37-47, 75-6, 355-72. A car made for transporting live stock, usually having a tight roof, but open grating sides and ends. *Double-deck* stock-cars are built for the carrying of sheep and hogs, and modern stock-cars are so designed that they can be used as double-deck cars if desired. In order to prevent suffering and injury to stock when carried modern stock-cars are provided with some of the devices that were formerly special to so-called *palace stock-cars*. New stock-cars are usually provided with at least the apparatus for feeding and watering.

Stop. 1. (Janney-Miller coupler.) The guard used to prevent the Miller hook from uncoupling by reason of lateral motion of cars.

2. (Miller coupler.) **13,** figs. 2290-2. A casting attached to the platform end-timbers of a car to limit the lateral movement of the hook on the adjoining car.

3. Anything which prevents or limits movement; usually called by the name of the object which it stops, as the following, which see.

<i>Berth-stop.</i>	<i>Outside window-stop.</i>
<i>Brake-lever stop.</i>	<i>Partition-stop.</i>
<i>Blind-stop.</i>	<i>Sash-lock lower-stop.</i>
<i>Center-stop.</i>	<i>Sash-lock stop.</i>
<i>Closed-door stop.</i>	<i>Sash-lock upper-stop.</i>
<i>Deck-sash stop.</i>	<i>Sash-stop.</i>
<i>Door-stop.</i>	<i>Seat-arm stop.</i>
<i>Drawbar stop.</i>	<i>Seat-stop.</i>
<i>Draw-spring stop.</i>	<i>Side-stop.</i>
<i>Floor-stop.</i>	<i>Spring-door stop.</i>
<i>Inside window-stop.</i>	<i>Ventilator-stop.</i>
<i>Open-door stop.</i>	<i>Window-blind stop.</i>

Stop-bar (sleeping-car). Fig. 2414; **49,** fig. 2409. A bar to connect the two seats on which the seat-bottoms may rest when drawn down to make up into beds. It rests upon a *stop-bar plate*, fig. 4270.

Stop-bar guide. Fig. 4245. An attachment to hold a

Stop-bar plate. Fig. 4270. See *Stop-bar*.

Stop-bead, or parting-strip. More properly *sash parting strip*. The strip dividing the groove for the window-sash and the groove for the blind.

Stop-bolt (of car-door lock). **G,** fig. 2630. An attachment for throwing a door-latch out of gear.

Stop-brace (Miller coupler). **14,** figs. 2290-2. An iron bar attached to the draft-timbers and to the lower end of a *stop* as a brace for the latter.

Stop-cock (for brake-pipe of air-brake). An *angle cock*. **25,** figs. 1693-8 and fig. 1745. A cock attached to the brake-pipe of a Westinghouse automatic brake so that the pipe can be closed if the brake-hose is to be uncoupled. If the compressed air were allowed to escape from the brake-pipe, the brakes would be applied.

Stop-key. See below and *journal-bearing stop-key*.

Stop-key journal-bearing. Figs. 5133-7. A key or wedge with a lug or projection which bears against the end of the axle to restrain lateral motion and thus dispense with a collar on the axle. See *Stop-wedge*.

Stop-latch. A spring door-latch with a *stop-bolt* by which the latch can be fastened on one side so as not to act. Also see *Saloon stop-latch*.

Stop-plate or wedge (for journal-box). **5,** figs. 5138-48, and figs. 5145, 5150-1. A metal plate which forms an end-bearing for the axle and checks its end-motion. It is held in position either by flanges cast in the box, or by attaching it to the journal-bearing or its key. Its object is to dispense with a collar. It is increasing in use and favor. See *Bissell stop-key journal-bearings*, figs. 5133-37. *C., B. & Q. journal-box and parts*, figs. 5138-45; *Adam's journal-box, etc.*, figs. 5146-51.

Stop-wedge. A *stop-key*. See *Stop-key journal-bearing*.

Storage heaters (car heating). Figs. 3009-10, 2959, 2961-7, and 3001. See *Direct steam storage*.

Storage-tank (Frost system of gas lighting). Fig. 3143. This tank is designed to be placed in the ground and is supplied with filling-plug, gage-pipes, pressure-gage, safety-valve and discharge-pipe; the latter extending to the bottom of the tank. When it is desired to draw gasoline into the *filling-can* (fig. 3142) air is forced under low pressure into the *tank* by means of the yard air-pipe or a small hand-pump. This air enters by means of the *check-valve*, **7,** and occupies the space above the oil in the tank. Then, by opening the *discharge-valve*, **5,** the oil is drawn rapidly and without loss into the filling-can.

Storm-sash fasteners. Figs. 4531-2.

Stove. An apparatus made usually of iron, variously constructed, in which a fire is made for warming a room, house or car by direct radiation. When the warming is effected by convection, as with warm air, hot water, etc., the entire apparatus is called a *heater*. Stoves are out of use for heating passenger-cars, but *cast-iron* stoves are largely used for cabooses-cars. *Cook-stoves* are largely used for heating emigrant-cars.

A cook-stove permanently fixed against the side of a room and directly connected with the chimney without the use of stove-pipe, is called a *range*; used in dining-cars, etc., figs. 3106-8.

Stove, stove-box, etc. (Street-cars.) See **208-15,** fig. 5654.

Spear caboose stove, figs. 3073-3105. *Erie caboose stove*, figs. 3061-72.

Stove-pipe. A tube, usually of sheet-iron, for conveying the smoke from a stove or heater and creating a draft. In heaters, commonly called *smoke-pipe* or *smoke-flue*, which see.

Stove-pipe cap. Figs. 3058-60. A U-shaped piece of sheet-iron fastened to the top of a stove-pipe, serving as a rough form of *jack*, which see.

Stove-pipe damper. A circular disk in the stove-pipe for regulating the draft.

Stove-pipe jack. **129,** figs. 435-73. A covering or bon-

net for the aperture of a stove-pipe on the outside of a car. The term usually means a more elaborate structure than a *stove-pipe cap*.

Stove-pipe ring. A metal plate or ring attached to the ceiling of a passenger-car around the opening through which the stove-pipe passes from the inside to the outside of the car. It is used for ornament or "to make a finish" around the opening for the stove-pipe.

Stove-plate. See *Bottom stove-plate*. *Ash-pit bottom*.

Stove-ring. A *stove-pipe ring*, which see, or a ring for Russia-iron casing of a Baker heater, figs. 2869, 2893, etc.

"Straight-air" (air-brake). A term applied to the original form of the Westinghouse air-brake. It has been replaced by the *Westinghouse automatic air-brake*, which see.

Straight closet hopper. Figs. 3865-6.

Straight-tank (tank-car). One with the rings or plates of metal placed alternately inside and outside of each other, in distinction from *telescope tanks*, figs. 373-9. See *Tank-car*.

Strainer (air-brakes). Figs. 1746, 1758-60; 16, figs. 1706-7; 106, figs. 1691-2. See *Air-strainer*.

Straining-rod. See *Brace straining-rod*.

Strap. A long narrow strip of leather, cloth or metal.

See <i>Axle safety-strap.</i>	<i>Door-strap</i> (street-cars).
<i>Bell-cord strap.</i>	<i>Double pipe-strap.</i>
<i>Bell-strap.</i>	<i>Drawbar-strap</i> (English).
<i>Brake equalizer strap.</i>	<i>Hand-strap.</i>
<i>Brake-safety strap.</i>	<i>Pipe-strap.</i>
<i>Dash-guard strap.</i>	<i>Roof-strap.</i>
<i>Diagonal roof-strap.</i>	<i>Safety-strap.</i>
	<i>Signal-strap</i> (street-cars).

Strap-bolt, or lug-bolt. Fig. 3712. A round bolt with a flat bar of iron welded to it, and usually with a hook on the end which serves the purpose of a head. The flat bar has holes in it, by which it is attached to a piece of timber or other object by one or more separate bolts or screws.

Strap-brake (hoisting-gear). 42, figs. 401-4. A method of controlling the spools by an iron strap which is pressed down upon the spool by a treadle.

Strap draw-bar. Figs. 1976-2019, 2099. A *spring-pocket drawbar*, which see.

Strap-hanger. Figs. 2503-10. See *Bell-cord hanger*.

Strap-hinge. 1. Figs. 2603-4, 2610. A door-hinge, the two parts of which are made longer than those of a butt-hinge, and of a triangular shape.

2. (English.) 71, figs. 348-51. In a freight car (*goods wagon*) a hinge in which the pin is welded to two flat bars at each end, and the main part of the hinge is turned while hot over the pin. The hinge has thus no loose part. The main part or strap is secured to the door, which it stiffens. The flat ends of the pin are bolted to the car.

Strap washer, or washer plate. 78, figs. 348-51. A wrought-iron strap which takes the heads of several bolts.

Street-car. Figs. 5642-67. A light car, usually with four wheels, constructed for carrying passengers on street railways. They are designated as *Cable*, *Electric-Motor* and *Horse* cars, accordingly as they are moved by cable, electric, or horse power. Electric cars are also called *Battery cars* or *Trolley cars*, depending upon whether the motor is supplied with electricity from a *storage battery* or from a wire by a *trolley*. *Horse-cars* are rapidly going out of use and being replaced by *electric* and *cable cars*. The *electric-motor car* bids fair to supersede all others on street railways, where the traffic is considerable. *Closed cars*, figs. 5642-6, 5654-58, 5663-67, have two longitudinal seats extending the length of the car, and seat 20-40 persons. *Summer* street-cars, 5647-9 and 5659-62, with reversible seats extending full width of the car, and seating from 50-70 persons are very largely used. *One-horse* street-cars are used for subordinate

lines. *Double-deck* or *top-seat* street-cars are common in Europe and are increasing in favor in this country. They are in service in Philadelphia, St. Louis and a few other places. Many electric cars are now equipped with two four-wheeled trucks, as shown in figs. 5646-7, 5651.

The first street railway in the world was the New York & Harlem, incorporated in 1831. The first cars were run November, 1832, from Prince Street to Harlem Bridge, the cars being in the form of three stage bodies carried on a single set of wheels, with side doors only, but with a perch at each end for the driver. The next street railway completed was the Sixth Avenue of New York, in 1852. Immediate and rapid growth there and elsewhere followed, and by the year 1858 street-cars were in use in all the large cities in the United States. A line in Paris was introduced in 1853, one in Cape Town, South Africa, in 1859, and one in Birkenhead, opposite Liverpool, in 1860.

Street-car center-lamp. Figs. 3250-1, 3308-17. See *Center-lamp*.

Street-car lamps. Figs. 3250-1, 3308-17. See also *Pintsch lamps*.

Street-car pedestal-springs. Figs. 5241-3, 5248, etc.

Street-car wheel. Figs. 5360-3. A light cast-iron, *single plate* or *open-plate* wheel.

Steel-tired wheels for electric-cars. Figs. 5270-3.

Strike-plate. Figs. 2638, 2649, 2730. The keeper for a *beveled* latch-bolt against which it strikes, so as to snap shut automatically. See *Keeper*, which is a general term including and often used as a substitute for strike-plate.

Striker-arm. Figs. 4092-3, 4099, etc.; 9, figs. 3917-25, 3967-76. A *seat-arm*, which see. The terms *striker-arm*, *seat-back arm* and *seat-arm* are used in the trade.

Striker-plate. See *Strike-plate*.

String-board (passenger-car steps). 48, figs. 435-73. A vertical board which supports the ends of the steps. A *step-hanger*.

Stringer. (Carpentry.) 1. "A horizontal timber connecting posts in a frame, as a tie-timber of a truss-bridge; a horizontal tie in a floor-framing."—*Knight*.

2. (Bridge construction.) The principal longitudinal timbers at the base of the roadway or track structure, analogous to the sills of cars. Hence, this name is often given to the sills of a car.

3. (Pile-driver cars.) 6, figs. 401-4. The *top-stringers*, which see.

Stringer sway-brace (pile-driver car). 4, figs. 401-4. Cross-bracing for the top-stringers.

Strip.

See <i>Diagonal roof-strip.</i>	<i>Parting-strip.</i>
<i>Living-strip.</i>	<i>Roof-strip.</i>
<i>Faenel-strip.</i>	<i>Sash-parting strip.</i>

Strut (of a truss). A member subjected to a strain of compression. A vertical strut is usually called a *post*.

Stud. 1. (Carpentry.) "A small piece of timber or joist inserted in the sills and beams between the posts to support the beams or other main timbers. The boards on the outside and the laths on the inside of a building are also nailed to the studs."—*Webster*. A vertical *scantling*, which see.

2. (Car construction.) 60, figs. 435-73. A short vertical wooden post in the side or end of a car between the window-posts, or below the windows, extending from the side-sills to the window-sills.

3. A standing bolt, pin, boss or protuberance designed to hold an attached object in place, especially one formed of a headless bolt permanently screwed into a tapped hole in a casting or forging so as to become a part thereof. See *Bracket-studs*. *Brake-block suspending-stud*. *Eccentric-lever stud*. *Spring-stud*.

Student lamp. Figs. 3399, etc. A lamp having a form of argand burner, which see, connected by a *feed-tube*, **K**, with a removable *reservoir* having a valve at the bottom

- to permit the slow escape of the oil. The reservoir is so placed that the level of the oil is very near to the flame. The whole lamp slides up and down upon a *standard*.
- Stuffing-box-nut and gland** (air-pump). 96, 97, figs. 1691-2. See *Piston-rod packing gland*.
- Sub-sill**. See *Buffing sub-sill* and *Back-stop timber*.
- Suburban excursion-car**. Fig. 151. A car with open sides and ends, which may be closed with curtains or blinds, for carrying passengers on suburban steam-roads in summer.
- Sulleys seal-lock**. Figs. 3898-a. See *Scal-lock*.
- Summer street-car**. Figs. 5647-9. See *Street-car*.
- Summer street-car curtain**. Figs. 4563, 5649. A cloth, usually made of heavy canvass, to inclose open cars and exclude rain or sunshine.
- Sun-burner** (mineral-oil lamp). Figs. 3373-5. A lamp-burner, of which a great variety of forms differing in minor details exist, but which all agree in being provided with a chimney, wide and cylindrical at its base, and held in place by a thin circular metal plate, cut with indentations around its outer edge, so as to act as springs. See *Sun-hinge burner*.
- Sundries** (bolts, jacks, pulleys, turnbuckles, etc.). Figs. 3708-3752. See *Miscellaneous Furnishings*.
- Sun-hinge burner**. Figs. 3373-4. A burner bearing an external resemblance to the *sun* burner, fig. 3375, and controlling the flame and air-supply in the same manner, but carrying the chimney like a *hinge* burner. A *no-chimney* sun-hinge burner, fig. 3374, is also used.
- Sun lamp-chimney**. Fig. 3418. See *Sun-burner* and *lamp-chimney*.
- Supply-pipe**. 1. (Air-pump.) 106, figs. 1691-2. A pipe through which the air enters the air-pump. More commonly called *air-inlet*.
2. (Lavatory fittings.) 9, 11, 12, figs. 3527. Pipes which carry water, hot or cold, to the faucets.
- Supply-valve** (of reducing-valve, train-signal apparatus). 4, fig. 2406.
- Support**. "That which upholds, sustains or keeps from falling, as a prop, a pillar, a foundation of any kind."—*Webster*. See *Cylinder-lever support*. *Drummond support*. *Pipe support*.
- Suspender-beam** (Miller platform). A short transverse piece of timber framed into the drawbar timbers underneath the end-sill.
- Suspending-link**. 23, figs. 1747, 1749. See *Brake-block suspending-link*. *Swing-hanger*.
- Suspending-plate**. 24, figs. 1747, 1749. See *Brake-block suspending-plate*.
- Suspending-stud**. 25, fig. 1747. See *Brake-block suspending-stud*.
- Sway-brace**. 4, figs. 401-4. A term borrowed from the similar parts used in trestles to designate any form of diagonal bracing, but more especially timber planking spiked on the main timbers of a structure. See *Stringer sway-brace*.
- Sweeping-car, or sweeper**. Fig. 217a. A car with rotary brooms for sweeping snow from a railroad track. The brooms are attached to a horizontal shaft which is connected by suitable gearing with the axles, and the brooms are thus made to revolve. Used in cities, and chiefly on electric roads. The car illustrated is driven by two twenty horse-power motors, and the brooms are driven by one twenty horse-power motor on the platform. The motors, electrical apparatus and all the levers for raising the mold boards and broom are covered with a cab.
- Swing-back car-seat**. Figs. 3917-18, 3982-7. A car-seat the back of which swings over the cushion, without reversing top to bottom. It requires that both sides of the seat may swing on either sides may swing on one head-roll. Used on freight truck,
- which see, for rapidly loading barrels, having a bail to throw over the head of the barrel for holding it in place.
- Swing-beam**. See *Swing-bolster*. *Swing spring-plank*.
- Swing-beam fitch-plates**. Figs. 5044-7. See *Fitch-plates* and *Swing-beam*.
- Swing-bolster**. 30, figs. 4740-6. A truck-bolster (so called in distinction from a *rigid-bolster*) which bears on springs that are supported by a transverse timber called a *spring-plank*, which is suspended by *hangers* or *links* so that it can swing laterally to the truck. As the springs rest on this plank and they support the bolster, the latter can swing with the spring-plank. The object of providing this swinging motion to the bolster is to prevent, as much as possible, lateral blows and shocks from being communicated to the car-body, and, *vice versa*, to prevent the momentum of the car-body from acting with its full force on the truck.
- All passenger-car trucks are swing-bolster. At the Master Car-Builders' Convention, 1884, the vote in favor of adopting the swing-bolster in a standard truck was 32 to 30, but the sentiment of car-builders *to-day* is largely and strongly in favor of the *rigid-bolster*.
- Swing-bolster spring**. 40, figs. 4943-6. See *Lateral motion spring*.
- Swing-hangers**. 46, figs. 4580-4757, 4842-4966. Bars or links attached at their upper ends to the transoms of a swing-motion truck, by which the spring-plank is suspended at their lower end so that it can swing laterally. Various forms are (1) solid bars with an eye at each end, 46, fig. 4742; (2) *swing-link hangers*, 46, fig. 4745, made like a long link of a chain; (3) those made with a fork or clevis at one end and an eye at the other, figs. 5074-5, and used on passenger trucks; and (4) those made with a very short link attached to an eye-bolt passing through the transom. These latter are called *eye-bolt link-hangers*.
- Swing-hanger friction block**. A casting, or bearing of considerable diameter, on which the upper end of a swing link-hanger rests. See also below.
- Swing-hanger friction-washer** (lower and upper). A cast-iron chafing block serving no other purpose than to take the wear. It is only occasionally used. A *friction* block is almost synonymous, but is usually a larger casting.
- Swing-hanger pivot** (*lower and upper*) (passenger-car trucks). 47-8, figs. 4740-6, 4942-4966. An iron bar by which a swing-hanger is suspended, or which supports a spring-plank. The lower swing-hanger pivot is more commonly called a *cross-bar* or *mandrel-pin*. The upper one is carried in a *swing-hanger pivot bearing* attached to the transom.
- Swing-hanger pivot bearing**. 49, figs. 4745. See above.
- Swing-hanger shaft**. A *swing-hanger pivot* or *cross-bar*, which see.
- Swinging-platform** (pile-driver car). Figs. 401-4. A platform carrying the entire pile-driving gear in such manner that it can be swung about at right angles to the car so as to project for a considerable distance on either side. It swings upon a *center-plate* and its movements are controlled by the *slewing-gear*, which see. A *cabin* is almost always built upon it, and the floor is constructed with sills and end-sills corresponding to those usually used in a car-floor. Removable *wings*, 20, are sometimes provided to support the swinging-platform when swung out in this manner. See *Pile-driver car*.
- Swinging-platform center-plate** (pile-driver car). 46, fig. 402. See above.
- Swinging-platform end-sill** (pile-driver car). 18, figs. 401-4. See above.
- Swinging-platform sill** (pile-driver car). 18', figs. 401-4. See above.
- Swinging-sash**. A window or blind sash which is hung and swings on hinges. See *Door-case sash* (street-cars). Otherwise rarely used.

Swing-joint (Cobb's pivoted seat-arm). Figs. 4092-3. More properly *seat-back pivot*. A pivot joint in the middle of the seat-back to which the *seat-arm* is attached. The old style seat-arm was rigidly attached to the seat-back at right-angles thereto.

Swing-links, etc. See *Swing-hanger*.

Swing link-hanger. 46, fig. 4740-6, etc. A swing-hanger, which see, made in the form of an open link.

Swing-motion. A term applied to an arrangement of hangers and other supports for the springs and truck-bolster which enables a car-body to swing laterally on the truck. See *Swing-bolster*. *Swing-hanger*.

Swing-motion gear. See above.

Swing-motion spring. 1. A *bolster-spring*, which see.

2. A *lateral-motion spring*. 40, figs. 4943-6.

Swing-motion truck. Figs. 4740-6. A truck with a bolster and spring-plank suspended on swing-hangers so that they can swing laterally to the truck-frame. Also called *swing-bolster truck* in distinction from a *rigid-bolster truck*. See *Canada freight-car truck*.

Swing spring-plank. 43, figs. 4740-6. A transverse timber underneath the *bolster* of a four-wheeled truck, or the *spring-beam* of a six-wheeled truck, on which the bolster-springs rest. A *swing spring-plank* differs from an ordinary spring-plank in being supported by hangers or links. See *Spring-plank*.

Switching. The act of moving cars from one track to another by means of switches, as in making up or separating trains, and placing the cars on the tracks and in the places where they are needed. Also occasionally called *drilling*, or *regulating*, and in England *shunting* or *marshaling*.

Switching-eye. More commonly *Push-pole corner-iron*, or *push-block*, which see. A cast-iron socket usually attached to the lower corner-plate of a freight-car, to which a *push-bar* or *push-pole* can be attached, to move the car by an engine on an adjoining track. A *roping-staple* or *pull-iron*, 58, figs. 229-66, is sometimes called a switching-eye.

Swivel (of a chain). A twisting-link, consisting of a headed pin, entering into an eye or ring in an adjacent link, as in the turnbuckle, fig. 3725. The object is to avoid kinking. Hence the term is applied to many forms of equivalent devices, consisting essentially of a ring surrounding a headed bolt in such manner as to permit rotation.

Swivel-turnbuckle. Fig. 3725. One of the commonest forms of turnbuckle, which see. See also *swivel*.

T

T, or Tee (pipe-fittings, which see). Figs. 2949-50. A T-shaped cast-iron tube for uniting one pipe at right angles to two others in the same line. The pipes are screwed into the arms of the T. A *reducing-tee*, which see, has the arms of different diameters.

Taber-burner. A burner similar to the *dual*, figs. 3367-8, except that it has two wicks in one tube instead of a separate tube for each wick.

Table (parlor and sleeping cars). 27, figs. 2409, 2412; 5, fig. 2453. A removable board attached to the side of the car by inserting a *table-hook* fixed to the table into a *table-hook plate* fixed to the side of the car. The inner end of the table is supported by a table-leg, which is sometimes vertical and sometimes *slanting*, which see. The tables of *dining-cars*, which see, are permanently fastened to the floor and sides of the car. A *drop-table*, figs. 474-5, is used in the kitchens of dining-cars.

Table-fastener. Figs. 4296-7. A latch by which a folding table is fastened up out of the way.

Table furnishings. Figs. 4286-98.

Table-hinge. Fig. 2602. A hinge for a table.

Table-holder. Figs. 4292-3. A special form of *table-hook*. See *Table*.

Table-hook. 45, fig. 2409, and figs. 4288-95. See *Table*.

Table-hook plate. 46, fig. 2409 and figs. 4286-7. See *Table*.

Table-leg hook. Fig. 4291. A metal hook which is attached to a *slanting table-leg*. It engages in a *plate* attached to the side of the car. See *Slanting table-leg*.

Table-leg hook-plate. See *Slanting table-leg*.

Tag (seal-lock). Figs. 3884, 3897-9. A loose label used chiefly in connection with seals. They are now often made of metal.

Tag-holder (seal-lock). Figs. 3897-9.

Tail-bolt. Figs. 3318-32. See *Drawbar-bolt*.

Tail-coupling for alcove faucet. Fig. 3472.

Tail-lamp, or tail-light. 1. A signal-lamp attached to the rear end of a train. They are always carried on the platform, usually in pairs, and very commonly also at the side of the car so as to be visible from the engine. They are often of two or more colors.

2. (English.) A colored signal lamp carried at the rear end of the last vehicle of a train. See also *Side-lamp*.

Tail-pin (Janney coupler). 142, fig. 2301. A short wrought-iron pin securing the *draft-bolt* to the *coupler*.

Tank. 1. (Passenger cars.) Figs. 3534-5, and 1, figs. 3542-7. A *water-tank* for the wash-room.

2. (Gas-lighting apparatus.) A, fig. 3160, 3165. More properly *receiver*, which see.

3. (Tank-car.) Figs. 48-9, 373-6. A boiler-iron receptacle for oil, sometimes made of uniform diameter or *straight*, but generally made *telescopic* by slipping each successive ring inside the other, so as to bevel the tank towards the middle, to afford better drainage. It is held in place by *tank-bands*, 107, figs. 373-6, fastened to *tank-band tie-rods*, F, on the top of a car to prevent the tank from turning. A *tank-dome*, 108, is added at the top and *dome-heads*, 109, are used to close the ends. A *tank-nozzle*, 115, is used for emptying the oil, closed by a *tank-nozzle cap*, 118, which latter is fastened to the nozzle by a *tank-nozzle cap chain*. The oil is drawn off through the *tank-valve*, 114, which see.

4. (Westinghouse brake.) 1, figs. 1699-1707. The *main reservoir*.

Tank-band. 107, figs. 373-6. See *Tank*.

Tank-band tie-rod. See *Tank*.

Tank-car. Figs. 48-9, 373-9. A car provided with a large *tank*, which see, for carrying oil, acids, molasses, paraffine, and in fact all liquids transported in bulk. By far the greater number of tank-cars are engaged in carrying crude and refined petroleum. Those used to carry the thicker oils, molasses and paraffine, are fitted with steam pipes, by which the contents may be melted or warmed to hasten its discharge. The number of such cars required to transport petroleum was very much lessened by the introduction of pipe-lines, of which some thousands of miles are now in use.

Tank-dome. 108, figs. 373-6. See *Tank*.

Tank-head. 106, figs. 373-6. See *Tank*.

Tank head-block. E, figs. 373-9. A block securely bolted to the underframe transverse to the sills, at either end of the tank, to prevent any longitudinal motion of the tank with respect to the car. The block is shaped to fit the end of the tank.

Tank-nozzle. 115, figs. 373-6. A short pipe used to empty the *tank*, which see. It is usually cast in one piece with the *tank-valve seat*, which see.

Tank-nozzle cap. 118, figs. 373-6. See *Tank*.

Tank-nozzle-cap chain. See *Tank*.

Tank-saddles. D, figs. 373-6. Floor distance blocks placed between the sills and curved to the contour of the tank, they support the *tank-slabbing*, which in turn carries the tank.

Tank-slabbing. C, figs. 373-9. Longitudinal strips or filling pieces underneath the tank of a tank-car, upon which the tank bears.

Tank-step (tank-car). A metal shelf or bracket fastened to the tank to facilitate access to the top of the dome.

Tank-valve. 1. (Tank-car.) 114, figs. 373-6. A valve attached to the bottom of the tank to draw off the contents.

2. (Water-cooler.) Fig. 3553. A valve used with water-tanks which extend to the roof, and sometimes with other smaller fixed tanks, for enabling them to be completely drained when desired. Also called *water-cooler valve*.

Tank-valve cage. 116, figs. 373-6. A metal inclosure, over the top of a tank-valve, as a guide for it.

Tank-valve rod. 117, figs. 373-6. A rod for opening and closing a tank-valve extending from the valve to the top of the dome.

Tank-valve seat. 115, figs. 373-6. A metal plate, with one opening in it, closed by the valve. It is riveted to the underside of the tank and has a *nozzle* attached to it to which pipes are connected for conducting the oil.

Tanner brake. A device for operating brakes on two trucks at once, invented by Mr. Henry Tanner, and patented in 1852. A difficulty with this form of brake was, that unless the adjustment of the connecting-rods and brake-shoes was perfect, the pressure of the brakes was not alike on the two trucks.

Target-lamp (operator's). A *signal-lamp*, which see, used for attaching to fixed targets or semaphore signals. No special form of signal-lamp is required or used for this purpose except that they be powerful and well-constructed lamps.

Tarpaulin, or wagon-sheet (English). A piece of stout, flexible waterproof painted canvas, measuring about 20 × 12 ft., used to protect the contents of open freight-cars (wagons) from the weather. Cords fastened to its edges are tied to *sheet-rings* (which see), by which it is firmly secured to the vehicle. It is largely used, as it saves much of the dead weight of a covered car, and gives good protection, except from theft.

Tassel. See *Window-curtain tassel*.

Tassel-hook. See *Window-curtain holder*. Tassels and tassel-hooks are now rarely used.

Taylor's interlocked-and-welded steel-tired wheel. Figs. 5316-17.

Taylor's manganese-steel wheel. Figs. 5318-19. See *Steel wheel*.

T-bolt (English). See *Spring-link adjusting-screw*.

T-bolt (long) (Janney coupler). The bolt passing through the *center buffer-spring*, and securing it to the yoke and equalizer.

T-bolt (short) (Janney coupler). The bolt uniting the *combination-yoke* to the *horn*.

Teak. An oily, hard and most durable wood, raised in India. Largely used for ship-building or other purposes requiring strength and exceptional durability. It has an oily, odorous sap, shrinks little, and does not corrode iron. Generally used for passenger-car bodies in England and for wheels.

Teak-wood center-wheel. Figs. 5320, etc. A form of steel-tired wheel, in which triangular blocks of teak-wood are used to connect the hub to the tire, which latter is attached to the wood by *Mansell retaining-rings*. This wheel is the standard for English passenger service, but it has been considered that it would not stand the dry American climate. See *Wheel, Car-wheel, Mansell wheel*.

Tee. See T.

Tee, with drip connection. (Consolidated car-heating.) Fig. 2982. Steam is taken from this tee to supply the heating-apparatus and the drip is returned to the drip connection cast in the same tee. The drip is thus prevented from freezing by contact with the hot train-pipe.

Telegraph-cock, or faucet. Figs. 3489-90. A self-closing valve for the key of a telegraph. When the water enters the key it is held horizontal tele-

graph-cocks, as figs. 3489-90. When it enters vertically they are called *vertical telegraph-cocks*. See *Faucet*.

Telegraph hand-car. Figs. 5611, 5608 (3-wheeled). A light hand-car for the use of telegraph linemen.

Telegraph-line-repairers' car. Figs. 5608, 5611, etc. Light velocipede-cars with a tool box large enough to carry a coil of wire, and necessary tools. They are sometimes made to carry several persons, as in fig. 5614.

Telescopic tank (tank-cars). See *Tank*.

Tender-brake. (Westinghouse brake.) Figs. 1699-1700, 1726. See *Westinghouse brake*. The Westinghouse tender brake-gear does not differ essentially from that used under cars except that the *Plain triple-valve* is used instead of the *Quick-action triple-valve*.

Tender-buffer. Figs. 2145-8, 2221-2. The buffer used on locomotive tenders so as to meet the buffers on passenger-cars equipped with the M. C. B. coupler.

Tender-coupler or tender-hook. Figs. 2145-9, 2221-2. The appliance for coupling locomotive tenders to cars equipped with M. C. B. couplers. See above.

Tender brake-cylinder (Westinghouse brake). Fig. 1726. See *Brake-cylinder*.

Tender drain-cup (Westinghouse brake). Fig. 1719. A larger cup than that used under cars. A chamber located in the train pipe containing an *Air-strainer* and from which a branch pipe leads to the triple-valve. A *tender-drain cup-cock* at the bottom is provided for removing the collected water.

Tender-hook. See *Tender-coupler*.

Tenon. The projecting end of a piece of timber fitted for insertion into a *mortise* by cutting away a portion on one or more sides. Sometimes the tenon is made cylindrical. Tenons are secured in their mortises by pins or by giving them a *dove-tail*, which see.

Tension-bar. Any bar subjected to a tensile strain. The upper member of an iron body-bolster, 1, figs. 1428-34, is called the *tension-bar*.

Tension-member (of a frame, truss, beam or girder). *Truss-rods, brake-rods*, etc., are tension members in distinction from *compression-members*, which see.

Tension-rod (of a derrick or crane). 15, figs. 389-96. A horizontal stay connecting the top of the *mast* and *boom*. It is of fixed length in a crane and of adjustable length in a derrick. See *Derrick*.

Tension-rod clevis (of a derrick or crane). A clevis, which see, sometimes carried at the upper end of a *boom* to which the *tension-rod* connecting the boom and mast is attached.

Test-bar (for limit gages). A bar for testing the correctness of *limit-gages*, which see.

T-hanger. See *Spring-hanger*.

Thacher dump-car. Figs. 28, 339-42. A side tip-car whose body is tipped or tilted by compressed air, from the locomotive. The bodies are tipped and returned to their normal position automatically by the admission of compressed air to two train-pipes. See *dump-car* and *tip-car*.

Theatre-seats (dining-cars). 8, figs. 2453-53a. An ordinary double car-seat having two separate seat-bottoms which can be raised up into a vertical position in the manner usual in theatres, in order to make the inner seats more easy of access. All modern dining-cars have these seats.

Thermometer (passenger-cars). Fig. 3705. A somewhat elaborate form of the familiar instrument for measuring temperature. It is usually conspicuous by its absence.

Thermostatic steam-trap (Gold's car heating). Fig. 3005. A device to regulate the escape of steam in proportion to the condensation that has taken place. It consists of a cast-iron shell or body with an inlet at the left and outlet at the bottom. In front of the inlet is a hollow brass diaphragm, O, shown, partly filled with an expansive fluid, adjusted and kept in place by lugs

round the sides of the trap body by a regulating spring, **S**, and the set-screw, **R**, seen in the cover. When cold the trap is always open, and the diaphragm, as in position shown, but as live steam is forced into the trap and comes in contact with the diaphragm, **O**, it immediately expands, and meeting the composition disc seat, **N**, closes the trap and prevents waste of steam. As condensation proceeds and the water cools, the diaphragm gradually contracts and allows it to pass off through the outlet.

A *Sediment well*, fig. 3007, is attached to each trap, the separating piece seen in it stops any dirt from being blown into the trap. This is important, as it prevents the seat from becoming clogged and saves renewal of parts. These traps should not freeze up, as they are open when cold, and no water remains in them. For the immediate discharge of the water of condensation of the pipes an automatic relief trap is placed below the trap on the *sediment well*, and this acts as an auxiliary to the steam trap. When the steam is shut off the relief trap opens and the water runs out through it.

Thielsen truck. Figs. 1937-40, 1821-4, etc. An all iron freight-car truck invented by Mr. H. Thielsen, having rolled iron *channel-bar* transoms riveted to a *transom-casting* at each end. It has been in general use, but in its original form is fast disappearing. Several modified types exist, as figs. 3729-34 and 4740-2, and a number of others not shown. The essential feature upon which the patent was claimed was in the riveting of the arch-bars and channel-bar transoms to the transom casting.

Thimble. 1. A bushing.

2. A sleeve or tube through which a bolt passes, and which may act as a distance-piece. A thimble is usually round, but sometimes square, as *smoke-pipe thimble*. See *Axle-safety bearing thimble*. *Body-bolster thimble*. *Brake-shaft thimble*. *Buffer-thimble*.

3. (Janney coupler.) A small casting in which the point of the catch-lever rests.

T-hinge. Fig. 2605. A door-hinge, one part of which is made like a *strap-hinge*, and the other like a *butt-hinge*, so that the shape of the whole resembles a letter T.

Third-class carriage (English). A car which performs much the same functions as an American so-called "first-class" passenger car, since it carries 89½ per cent. of the passengers, but very dissimilar in arrangement, weight and size. It generally weighs about 20,000 lbs. and is carried on four or six wheels, divided into five compartments, and seats fifty passengers. The seats and backs are comfortably shaped and upholstered in rep, stuffed with horsehair. Sofa springs and carpets are usually omitted, but parcel-nets and shades are provided. The comfort of this class of carriage has been very much improved of late years, but the interior finish is considerably inferior to that of ordinary American cars, the interior being generally painted and grained.

Thomas' steel-tir-d wheel. A wheel invented by Theodore Thomas, the essential feature of which is the use of wooden *cushioning-blocks* inserted in *cushioning-pockets* in the *wheel-center* so that the *tire* bears entirely upon these compressed blocks. The wooden cushioning blocks are forced into the cushioning pockets under pressure.

Thread. See *Screw-thread*.

Three-group graduated bolster-spring. Fig. 5211-12. See *Graduated Spring*. *Spiral spring*.

Three-group spiral spring. Figs. 5208-10. See *Spiral spring*.

Three-link drawbar. A *Potter* drawbar.

Three-way cock (Westinghouse brake). A cock formerly carried on the locomotive for applying and releasing the brakes. It has been supplanted by the *engineer's brake* and *equalizing discharge-valve*, figs. 1710-12, which see.

Three-wheeled hand-car. Figs. 5605-11. A light hand-car with two wheels on one rail, somewhat like a velocipede, and a third wheel on the opposite rail merely to steady the vehicle. They are worked either with levers operated by the hands, or by treadles with the feet, or by both hands and feet. See *Hand-car*.

Threshold, or threshold-plate. 1. (Passenger-cars.) A *Door-sill*, which see.

2. (Of a vestibule.) Figs. 1399-1400. The plate which covers the buffer-plate and connects it with the platform forming an adjustable threshold for the end-door, etc.

Threshold-plate washers. Figs. 1421-3.

Throat (of a car-wheel). The interior angle of a flange where it joins the tread of the wheel. See *Flange*.

Throat-piece (snow-plow framing). 17-20, figs. 410-13. (Side, center and intermediate throat-pieces.) The curved ribs connecting the inclined plane of the plow, with the deck, being curved they give a projection to the deck, which lessens the tendency of the snow to ride over the top of the plow.

Throttle-valve (Westinghouse brake). Fig. 1720, and 13, figs. 1699-1707. An angle globe-valve (*i. e.*, one having the entrance and exit pipes at right angles to each other) attached to the locomotive for admitting steam to and shutting it off from the air-pump. Called a steam-valve.

Through body-bolt (English). 75, figs. 348-51. Nearest American equivalent, *sill-and-plate rod*. A bolt passing vertically through the body and securing the various parts of the sides or ends together.

Thrust, top and bottom. 149, 150, fig. 2301. See *Janney-Buhoup platform-equipment*.

Thrust-bolt (Janney-Buhoup platform-equipment). 174, fig. 2301.

Thumb-lever (Hartley chair). 10, figs. 3998-9. The catch or lever by which the position of the head-rest is controlled.

Thumb-piece. 3, fig. 4477. A general term applied to many forms of lugs or projections for moving springs, catches, or other movable mechanical parts.

Thumb-screw. A screw with two projecting flat-sided flanges adapted to be turned with the finger and thumb.

Thurmond-McKeen car-coupler. Figs. 2209-20. A coupler consisting of three essential parts, made of steel and malleable iron. Some advantages claimed for it are that the flanges on the knuckle interlock the drawhead so that the pivot-pin is relieved of both the buffing and pulling strains. The lock has an automatic set so that the knuckle can be unlocked and left so even when cars are jammed together. A curve notch in the lock enables cars to be coupled on very sharp curves. As soon as the car is on a tangent the lock engages in full.

Thurmond-McKeen platform and coupler. Figs. 2277-81.

Thurmond-McKeen tender-hook. Figs. 2221-2. A tender-hook which depends upon gravity to center it. It can be pulled aside on curves for yard work so that it will couple on curves.

Ticket-holder. A metal clip or spring attached to the side of a sleeping-car berth for holding the tickets of the occupant of the berth. They are now rarely if ever used, on account of the danger of theft, tickets being collected by the sleeping-car porter for the night.

Tie. "A beam or rod which secures parts together and is subjected to a tensile strain. It is the opposite of a strut or straining-piece, which acts to keep objects apart, and is subject to compressing force."—*Knight*.

Tie-bar. A bar which acts as a tie. See *Draft-timber tie-bar*. *Pedestal tie-bar*. *Pedestal-brace tie-bar*. *Transom tie-bar*.

Tie-bolt (Janney coupler). A long bolt passing through the end-sill and holding on the *buffer-beam* outside of the *platform end-timber*.

Tie-plate. 1. A *main carline*, which see.

2. (Iron-frame car.) Flat plates riveted to the top flange of the iron sills, usually over the bolsters and

sometimes between them, to connect the sills together and serve the same purpose as the *floor-timber distance-blocks* and *sill tie-rod*, with wooden sills.

Tie-rod. A rod which acts as a tie.

See *Body-counterbrace tie-rod.* *Girth tie-rod.*
Brake-block tie-rod. *Lever-frame tie-rod.*
Cylinder-lever tie-rod. *Platform tie-rod.*
End-brace tie-rod. *Safety-beam tie-rod.*
End-girth tie-rod. *Sill tie-rod.*
Wheel-piece tie-rod.

Tie-timber. See *Cross-frame tie-timber.*

Tiffany refrigerator-car. An ice and salt car belonging to the class of cars having the ice-supply on the roof.

Timber. A stick of wood of considerable size.

See *Brake-hanger timber.* *Platform end-timber.*
Cross-frame tie-timber. *Platform-timber.*
Diagonal floor-timber. *Rocker-bearing timber.*
Draft-timber. *Rocker-timber.*
Drawbar cross-timber. *Spring-plank timber.*
Draw-timber. *Transverse floor-timber.*
Pedestal-timber. *Wheel-timber,* etc.

See also *Block, post, sill,* etc.

Timber-wagon (English). A short four-wheeled flat-car with a swiveling bolster, chains, posts, etc., adapted to carry timber in the log, which rests on two or three *timber-wagons* coupled together.

Tin car-roof. A roof consisting of a layer of boards resting on the rafters and running lengthwise to the car, covered with tin plates, the edges of which are soldered together. Used on passenger-cars, and a somewhat similar roof of galvanized iron is the *Excelsior galvanized car-roof* made for freight-cars, figs. 2385-8.

Tip. Figs. 1267-73. An ornamental knob on the end of a rod. More commonly called *acorn*. See *Basket-rack tip.* *Berth curtain-rod tip.*

Tip car. Figs. 28-30, 336-46. A car constructed so that its body can be tipped to allow its contents to slide out. Often also called *dump-car*. They are usually *four-wheeled*, rarely *eight-wheeled*. A style of four-wheeled tip car, which is slowly tipped by gearing, which winds a chain, is shown in figs. 336-8 that has gained considerable favor on the Boston & Albany Railroad.

Cars which are tipped by compressed air have been introduced and received with considerable favor. One of these is shown in figs. 28 and 339-42. The advantages secured by the use of air are that cars may all be dumped at once and the bodies restored to their normal positions; they may be dumped while in motion, and they are all under the control of the man on the locomotive. The dumping and restoring of car body is effected by two train pipes, in the *Thacher car*, while the *Trapp car* (not shown) is provided with an auxiliary reservoir, and the dumping is effected in much the same way that the brakes are applied under the Westinghouse system.

Mine cars are frequently *tip-cars*.

Tip-car door. 62, figs. 336-42.

Tire. A heavy hoop or band of iron or (usually) steel forming the ring or periphery of a wheel to impart strength to it and to resist wear. In this country car-wheels are generally *cast*, but within a few years steel-tired wheels have come into general use for passenger service. They have been universal in European practice, and many devices for fastening them securely to the wheel have been devised. See *Tire-fastening*.

In England the word is usually spelled *tyre*. The name is supposed to come from the fact that iron bands were first used on wheels in the city of Tyre, Syria.

Tire-bolt. Figs. 5339-40, 5347. A screw-bolt for holding a tire on a wheel-center. When *retaining-rings* are used the bolts pass through the rings and hold them and the center and tire together.

Tire-fastening. Figs. 5255-5337 show the principal methods.

5320, 5347, etc., is

the method in which the wheel becomes

and the tire alone is insuffi-

cient to prevent the latter leaving the wheel. In England the methods shown in figs. 5342-3, 5347, are the most approved. No tire fastened by either of these methods has ever left the wheel, even when the tire has broken. In America the *Mansell retaining-rings*, figs. 5261-4, etc., the *Gibson fastening*, figs. 5274, etc., the *Boies tire-lock*, figs. 5284, etc., are quite common. The *Brunswick*, figs. 5292, etc., the *Bute*, fig. 5299, and the *Snow fastening* are modified forms of the *Gibson fastening*. See *Car-wheels* and *wheels*.

Toe (of a car-wheel flange). The extreme outer point where the wheel has the largest diameter.

Toe-nail. A nail driven in obliquely to fasten the end of a board or other piece of timber to the surface of another. The stick so fastened is said to be *toed*, or *toe-nailed*.

Toggle-arms. H H, fig. 324a. The two arms of a toggle-joint, which in fig. 324a form a strut between the two opposite hopper-doors, holding them closed.

Toggle-joint. "An elbow-joint; a joint between two bars articulating endwise, as the human knee."—*Knight*.

Toggle-joint and bar. 30, figs. 2429-30. (Barr vestibule.) A device to force the *Front-face-plate* out from the car-body. See *Barr vestibule*.

Toilet. Another name for a *saloon*.

Tongs, or crabs (pile-driver and wrecking-cars). 22, figs. 401-4, etc. A device for anchoring the body of the car to the track when in use. A *jack-screw* is used in connection with the tongs to raise the body of the car, so as to bring a strain upon the tongs. See *Bolster jack-screw*, which is a different device for the same purpose.

Tool-box. 1. Fig. 85. A box very frequently placed under the body of the car, especially in caboose, derrick or wrecking-cars, for carrying tools and supplies.

2. T, fig. 540. A rectangular wooden box with a glass front, in which are kept tools to be used in case of accident. It usually contains an axe, a saw, a sledge and a bar. A ground-glass front is sometimes used.

Tool-car. A box-car arranged for carrying all kinds of tools, ropes, etc., which are used, in case of accident to trains on the road, in replacing or removing the cars or engines on or from the track. Such cars are often used when any heavy objects are to be moved, as is necessary in erecting bridges, etc.

Tool-cars are often fitted up with sleeping berths for workmen. A tool-car usually serves as a tender for every wrecking-car.

Tool-case. See *Tool-box*, 2.

Top. See *Base-top, cast-iron top, main-top, smoke-top*, etc., of *Baker*, and other heaters, figs. 2865-2929, 3058-3105.

Top arch-bar. More properly, simply *arch-bar*, which see.

Top-chord (of a truss). The upper outside member of a truss, especially one divided up into panels. The members of mere *trussed beams*, are not commonly designated as chords.

Top (or upper) **cylinder-head** (Westinghouse driving-wheel brake-cylinder). 5, fig. 1747. See *Cylinder-head*.

Top door-rail. 149, figs. 435-73, 540, etc. The uppermost horizontal bar or piece of a door-frame.

Top door-track. 65, figs. 229-66. See *Door-track*.

Top end-rail (coal-car). 137, figs. 332-5. A horizontal stick of timber which forms the top of the end frame.

Top-head (air-pump). 2, fig. 1689; 60, fig. 1691-2. The top cylinder-head of the pump together with the valve-seats, valves, etc.

Top light-rail (English). 103, figs. 501-4. A part of the body framing of a carriage forming the top of the window opening.

Top panel-batten (English). 107, fig. 501. American equivalent, *furring*. A part of the body-framing to stiffen the top-panel, which is pinned to it.

Top-plate. Figs. 2912, 2931. Similar parts are used in nearly all stoves. See *Top*. *Outside top-plate*. *Inside top-plate*.

- Top-plate** (iron body-bolster). 1, figs. 1428-67. See *Body-bolster*.
- Top-rail** (of door). See *Top door-rail*.
- Top-rail**. 47, figs. 5654-67. A name applied sometimes to the *plate* of a street-car.
- Top-rail filling-strip**. 175-6, fig. 557. See *Filling-piece*.
- Top-rail of pipe-box**. 225, fig. 554.
- Top-reservoir journal-box**. 34, figs. 348-1. A journal-box having a reservoir for oil or grease above the journal, from which the oil flows to the journal. Rarely used in this country, but common in Europe, with either oil or some form of grease as a lubricant.
- Top-seat street-car**. Figs. 5650-2. See *Street-car*.
- Top side-bearing**. A *body side-bearing*. See *Side-bearing*.
- Top side-rail** (coal-car). 136, figs. 332-3. The horizontal piece of timber which forms the top of the side. A similar part in roofed cars is called the *plate*.
- Top-stringers** (of pile-driver car). 6, figs. 401-4. See *Leader*.
- Torch and key** (Pintsch system). 300, fig. 3229. A special device combining the ordinary wax taper torch, and a key, fitted to handle the cock of any Pintsch lamp, as well as to open or close the globe of any lamp from the floor of the car.
- Tornado canopy ventilator**. Fig. 4305. See *Ventilators*.
- Tornado ventilator**. Fig. 4299. See *Ventilators*.
- Tornado-lamp**. A general term applied to lamps which receive their supply of air through a long tube, usually connected with the supports or arms of the lamp, so as to check the effect of sudden gusts of wind. Figs. 3261-2 are on this principle. *Hurricane-lamp* is another name for the same thing.
- Torpedo**. Fig. 3724. A cylindrical detonating cap provided with clips for folding under the head of the rail for the purpose of making a loud alarm as a signal on the passage of engines over them. The basis of the detonating compound is fulminate of mercury. The interior pieces of iron, to insure the explosion of the fulminate, are termed *anvils*. Some torpedoes have three anvils. A torpedo with spring clips has been introduced for attaching to the track from the rear end of a train in motion by means of a patented *carrier* to be held in the hands of the trainman, which insures that the torpedo will not escape except to clasp the head of the rail. The same device is also used to attach blue-lights to the track, burning for a fixed length of time.
- Torpedo ventilator**. Fig. 4316. See *Ventilators*.
- Torrey door-spring**. Fig. 2815. See *Door-spring*.
- Tourist-car**. Figs. 152-4. 1. A car roughly built and furnished for the transportation of men alone, such as bodies of troops, parties of excursionists, emigrants, etc. Frequently they are *flat* or *box-cars* furnished with roof sides, seats and doors, as in figs. 153-4 and 497-500. The *emigrant sleeping-car* is now usually called a *tourist-car*, the latter being preferred by those who patronize them.
2. A private car, one of several, of elaborate finish and luxurious appointments, chartered by excursionists who are making a tour of the country.
- Towel-rack**. Figs. 3517, etc. A tray for holding clean towels.
- Towel-rod**. Figs. 3591, etc. A rod with *brackets* or *bushings* at the ends upon which towels may be hung.
- Towel-roller bracket**. Figs. 3563, etc. A bracket for supporting a *towel-roller*. There are two, the *fixed-end* and *loose-end* bracket. The principal supply of towels, however, is usually carried in a towel-rack or hung on towel-rods.
- Towel-rod brackets**. Figs. 3558, etc. See *Towel-rod*.
- Tower-coupler**. One of the M. C. B. types of vertical-plane automatic car-couplers.
- Track**. 1. A rail or bar which forms a path on which anything, as a car or door, runs. Sliding-doors have usually two door-tracks, *bottom* and *top door-track*.
2. (Pile-driver car.) 47, figs. 401-2. A circular track upon which the rollers of the swinging-platform travel. A *rack* is connected with it as a part of the *slewing-gear*.
- Track and wheels, terms and gaging points**. Fig. 5485. See *Wheels-and-track*.
- Track-laying car**. 1. Fig. 5603. A low push-car primarily for carrying rails short distances in construction. They are frequently without a floor or platform and are provided with fixed rollers at the side for running the rails forward.
2. A platform car with a cantilever truss extending out from one end of the car over the track and on which rails may be run out and distributed on the ties.
- Track-sweeper**. Fig. 217a. A *sweeping-car*, which see. For city use only.
- Train brake-pipe**. 16, figs. 1693-8. See *Brake-pipe*.
- Train-car**. A *caboose-car*, which see.
- Train-pipe**. (Train brake-pipe.) See *Brake-pipe*. The later and preferable name is *Train brake-pipe*.
- Train-pipe valve and thermostatic steam-trap** (Gold's car-heating). Fig. 3005. A train pipe-valve is a combination of valves, cocks and steam traps, by means of which the steam supply from car to car is controlled from the interior of each car, thereby simplifying the application of any system of equipment for steam heat from the locomotive. See *Thermostatic steam trap*.
- Train signal-lamp**. Figs. 3318-32. A lamp attached to a car as a signal, usually to the last car on a train, and commonly called a *tail-light*. See *Signal-lamp*. They are usually some form of lantern. Lanterns of ordinary form, but with red globes, are also used.
- Train-signaling apparatus** (Westinghouse). Figs. 2388-2407. A substitute for the bell-cord arranged to give train signals by compressed air. A separate line of *signal-pipe*, 27, fig. 2388, similar to the brake-pipe extends throughout the train, connected between the cars by hose and couplings. A *car discharge-valve*, 32, connected to this signal-pipe, is located in each car and attached to the bell-cord, in such manner that pulling on the cord releases air from the signal-pipe. On the engine is a *signal-valve*, 26, which is also connected with the main signal-pipe and a small *signal-whistle*, 23. The supply of air is received from the main reservoir through a *reducing-valve*, 24, which maintains a pressure of about 40 lbs. per square inch in the signal apparatus.
- When the car discharge-valve is opened, by pulling on the cord, the *diaphragm* in the signal-valve is operated so as to blow the whistle. Signals can be given in this way with rapidity and great certainty. If the train breaks in two the whistle is blown loudly for a considerable time.
- Train signal-pipe**. See *Signal-pipe*.
- Train-signal stop-cock**. 28, figs. 1693-8. A stop-cock in the *signal-pipe*. There is one at each end of a car.
- Transfer-plug**. (Frost system of gas-lighting.) Fig. 3145. This plug is designed for transferring the gasoline from the shipping barrels to the storage-tank (figs. 3143). The *plug*, 1, is to be screwed into the bung-hole of the barrel and the *discharge-valve*, 2, adjusted to drain the lowest part of the barrel. One end of the hose, which is attached to the discharge-pipe, is then placed in the *filling-plug hole*, 5, of the storage-tank and air under low pressure admitted to the shipping barrel by means of the small *pipe*, 5, in the side of the plug. The gasoline is then forced rapidly from the barrel to the *tank*.
- Transfer-table**. Figs. 93, 105, 118, 129, etc. A platform and section of track on wheels, its length being equal to the length of a car. Its chief use is to transfer cars from one section of a shop to another, connecting with parallel tracks and running transversely to them.

Transom. 1. Primarily a cross-piece.

2. (Carpentry.) A horizontal piece framed across a door or double-light window. The term is also applied in the general sense of a cross-piece in other ways.

3. (Car-building, swing-bolster trucks.) 20, figs. 4740-6. One of two horizontal cross-beams attached to the side-frames, between which the swing-bolster is placed. They are usually made of wood, but recently they have been made of iron. They are in some forms of truck, which are not *swing-motion*, as in figs. 4729-34. See also *Middle-transom*. *Outside-transom* (six-wheel trucks, figs. 4957-66).

4. 22, figs. 229-66; 26, figs. 435-73. The *body-bolster* is also sometimes called a *transom* or *body-transom*, but incorrectly. The term *body-transom* is more properly limited, when used at all, to the *cross-frame tie-timber* or *needle-beam*, which see.

5. A word frequently used in street-car work as an adjective, for the word "deck," and meaning that the part belongs to the upper deck-windows or to the clear-story.

6. (English.) Commonly spelled *transome*, which see.

Transom bearing-block. A piece of wood or iron placed on top of a transom, under the attachment or bearing of a swing-hanger, to raise it up higher.

Transom-casting. 28, figs. 4740-6. A casting attached to a truck-frame and to which the end of one or both of the transoms are fastened.

Transom chafing-plate. 27, figs. 4744, and 4957-66. A plate attached to the side of a transom to prevent it from abrasion.

Transom corner-plate. (Passenger-trucks.) Figs. 4006-8, and 131, figs. 4963-66. See *truck-frame corner-plate*.

Transome (English). 3, figs. 348-51, 501-4. A *cross-frame tie-timber* or *needle-beam*, which see. More commonly called *cross-bearer*, which latter term is also in use in this country.

Transom-muntin or mullion. 176, 177, fig. 5662. See *Mullion*.

Transom-opener. Fig. 4334. A device for opening a transom over a door; very similar to a deck-sash opener.

Transom-pillar (diamond-trucks). A small casting acting as a distance-piece between the transom and inverted arch-bar.

Transom-plate. Figs. 5054-5. Iron plates on both sides of wooden transoms of six-wheeled trucks.

Transom sash-stop. Fig. 4401.

Transom tie-bar. 23, figs. 4942-6. A wrought-iron bar bolted to a pair of transoms, sometimes above and sometimes below, to hold them together.

Transom truss-block. See *Transom truss-rod*.

Transom truss-rod. 24, figs. 4955-7. Transverse rods attached at their ends to the wheel-pieces, which extend alongside the transoms and are inclined downward under a central *transom truss-block* so as to strengthen the transoms. Generally, two such rods are used with each truck. In the Pullman 6-wheel trucks, figs. 4963-6, a *transom-plate* is used with a straight *transom tie-rod*.

Transom truss-rod seat. Figs. 4878-9. A bearing for the *transom truss-rod* on the under side of the transom.

Transom truss-rod washer. 26, figs. 4955-66. See *Washer*.

Transverse floor-timbers (street-cars). 12, figs. 5654-67. Timbers which extend across the car underneath the floor and on which the latter rests. They are used only when there are two sills. Not to be confused with *cross frame tie-timbers*, which are under the sills.

Transverse floor-timber plate. 13, figs. 5654-5. A wrought iron or steel plate to strengthen the *transverse floor-timber* and act as a tie-rod for the *floor timber*.

See also *Rising* 23-31. See *Rising*

Transverse tie-rod (English). 10, figs. 501-4. American equivalent, *sill tie-rod*. A long rod which serves to bind together the *underframe* transversely.

Trap (for refrigerator car). An S-shaped pipe largely used in all forms of plumbing work for permitting the exit of water while preventing the entrance of air.

Trap cock (Consolidated car-heating). Figs. 2980-1. The trap cock is an asbestos-packed cock in which the plug has an opening of the proper size to regulate the flow of water from a car. It takes the place of the trap in the Commingle system, the use of the trap itself having been abandoned.

Trap-door. 1. A door in a floor or roof, closing flush therewith when shut. See also *Platform trap-door*.

2. (Janney-Miller coupler.) A small iron door in the platform giving access to the center buffer-yoke.

3. (Pullman extended vestibule.) Fig. 2438. A door which covers the platform steps and makes a continuous level floor for the full width of the car in an extended vestibule.

4. 36, figs. 5654-67. A door of a street-car in the floor which gives access to the motor and gearing between it and the axle.

Trap-door spring (Janney-Miller coupler). The spring used to keep the trap-door securely closed.

Trap-valve (Consolidated car-heating). Fig. 2976. This trap valve is designed to take the place of the thermostatic trap. It gives an adjustable opening for the discharge of water from the heating apparatus. It also leaves the apparatus so that it can be entirely closed off so as to prevent the water from flowing from the heating apparatus.

Traversing hydraulic-jack. Fig. 3742. A jack that can be moved horizontally on a bed or track while under its load.

Tread. 1. (Of a step.) The part on which the foot is placed. See *Tread-board*. *Rubber-tread*.

2. (Of a car-wheel.) Figs. 5334, 5424. The exterior cylindrical surface of a car-wheel inside of the flange which comes in contact with the rail. The usual width is about 4 in., measured from the throat or inside of the flange, and about 5½ in. out to out measurement, from outside of flange to outside of wheel. The standard section adopted by the M. B. Association in 1886 is shown in fig. 5424, and in figs. 5487-9.

Tread-board (of a step). 46, figs. 435-73. The horizontal part on which the foot is placed.

Treadle (for hand-car brake). In fig. 5595. (For pile-driver car winding-gear.) 42, figs. 401-4. A foot-lever connected to any form of machinery or to a brake, for actuating or controlling the same.

Triangular washer. Fig. 3721. An iron plate or block, the cross-section of which is triangular, and which forms a bearing for the nut or head of an inclined brace-rod. Also called *beveled washer*, but the latter term is chiefly used when the angle between the two faces is small, figs. 3717-18.

Tri-colored inspector's lamp. An *inspector's lamp*.

Tri-compo, or tri-composite carriage (English). A composite coach in which separate compartments for first, second and third class passengers are provided.

Trigger. See *Sash-lock trigger*. 2, figs. 4477.

Trimming-cap. A *car-seat molding*, which see. Figs. 4023-8.

Triple-coil nest-spring. Figs. 5250-3. See *Spiral spring*.

Triple coupling-link. A kind of chain used with the *draw-hooks* of English draw-gear. Used in America for small four-wheeled coal-cars only.

Triplet (of elliptic springs, which see). Figs. 5333-4.

Triple-valve (air-brake). Figs. 1706-7, and 1750-1 and 5, figs. 1693-8. 1. A valve device consisting of a body or case, called the triple-valve body, which has connections to the train-pipe, the auxiliary reservoir and the brake-cylinder, in which a slide-valve is operated by a piston so that when the pressure of the air in the train-pipe

is increased, the auxiliary reservoir is charged and the air in the brake-cylinder is released to the atmosphere; and so that, when the air-pressure in the train-pipe is reduced, air from the auxiliary reservoir is discharged into the brake-cylinder for applying the brakes. A triple-valve performing only these functions is now known as the plain triple-valve.

2. The quick-acting triple-valve has all the features and performs all the functions of the plain triple-valve, and has the additional function of causing a discharge of air from the train-pipe to the brake-cylinder, when, in emergencies, the maximum force of the brakes is instantly required.

3. (For freight air-brake gear.) Figs. 1728-9. A special form not differing in principle from the passenger brake-valve, but generally combined with the reservoir and brake-cylinder in one single part for economy and convenience of attachment.

Triple-valve bracket and nipple (Westinghouse brake). Fig. 1723-4. A four-legged standard in the nature of a distance-piece to which the triple-valve is attached.

Triple-valve branch-pipe (air-brake). 20, figs. 1693-8. A short pipe by which the triple-valve is connected with the brake-pipe.

Tiple-valve piston (air-brake). 4, fig. 1706. See *Triple-valve*.

Tripod. 1. A three-legged stand.

2. (For lamp-shade.) Fig. 3435. A cheap substitute for a *shade-ring*.

Trojan car-coupler. Freight, figs. 2223-39; passenger, figs. 2267-74. One of the M. C. B. types.

Trolley (street-car). A small wheel, or a carriage with journal, bearings, case, etc., usually attached to the end of a *trolley-pole*, the latter being attached, pivoted and swiveled to the top of a street-car, and so stayed by springs that it tends to stand in a vertical position. This tendency of the trolley-pole to stand erect keeps the trolley-wheel in contact (on the under side), of an electric conductor stretched above the car over the center of the car-tracks. Electric motor-cars which drive the electric current through a *trolley* are called "*Trolley-cars*," fig. 5644. The majority of electric motor-cars in use at the present time are "*trolley-cars*" taking the current from an over-head conductor.

Trolley-board (street-car). 154, figs. 5654-8. A board or several boards making a long, narrow platform (very much like a *running-board* of a freight-car), to which the *trolley-pole* is attached and on which inspectors and repairmen may stand. The boards rest upon *trolley-board cleats*. *Trolley base-blocks* are fastened to the trolley-boards, and the trolley-pole is fastened to the base-blocks.

Trolley-inspection steps (street-car). 149, figs. 5654-8. Steps fastened to the corner-post of a trolley-car, on which an inspector can ascend to the roof.

Truck. 1. "A small wheel; hence *trucks*, a low carriage for carrying goods, stone, etc., either on common roads or on railroads. Indeed, this kind of carriage is often called a *truck*, in the singular."—*Webster*. The term is applied to different kinds of small vehicles used on and about stations for handling freight and baggage by hand, sometimes in a confused sense. The usage seems to be increasing, however, to speak of baggage *barrows* and freight *trucks*, although both are sometimes designated as *barrow-trucks*, figs. 5637-41. Four-wheeled vehicles, called *baggage wagon-trucks* and *freight wagon-trucks* are also used. Vehicles of this class are also designated as *warehouse-trucks*. Special varieties shown are the *telescope*, *swing-barrel* and *self-loading trucks*, figs. 5635-6, 5641. Many others exist in limited use.

2. Figs. 4576-4966. A *car-truck*, which is, mechanically, a small four-wheel (or sometimes six-wheel) car, under each end of an American car-body and carrying the latter as a dead load by means of two swiveling

center-plates connected by a *center-pin* or king-bolt. The purpose of the truck is to enable short wheel-bases to be used in connection with long car-bodies. See *Car-truck*. The credit of the invention of the truck has been disputed, but it seems clear that it belongs to John B. Jervis, Chief Engineer of the Delaware & Hudson Canal Co. and of the Erie Railroad during its construction. Passenger-car trucks are nearly always of wood in combination with iron fitch-plates, truss-rods, etc. For freight-car trucks wood has almost passed out of use except for the transoms, truck-bolsters and spring-planks, and iron is being rapidly substituted for the latter as well. Even when wood is employed it is frequently strengthened by iron or steel plates. Wooden brake-beams are the exception. For spring planks, transoms and bolsters, the common structural forms of channels and eye-beams are used. The standard freight-car trucks as now built is almost invariably of the *diamond-truck* pattern, figs. 45767, 4580-2, 4644-8, etc., and the *rigid bolster truck* is in greater favor. Swing-motion trucks retain some features of the Thielsen iron truck, the iron or steel channel-bar transoms, as in figs. 4740-2, and the same features have been adapted to rigid trucks as in figs. 4729-34. At the convention of the M. C. B. Association, 1893, a committee submitted a lengthy report of tabulated replies on the subject of trucks and the experience of master car builders with *rigid* and *swing bolster* trucks. In answer to the question, "If you were contemplating making a change, would you adopt a *rigid* or a *swing bolster truck*," 34 replied in favor of the *rigid* bolster and only 4 in favor of the *swing bolster* trucks. See proceedings M. C. B. Association, 1893, page 201.

In 1894 the replies stood 14 to 27 in favor of the *rigid bolster* truck even though the *swing-bolster* truck cost no more for construction and maintenance, which, it is conceded, it does. Proceedings 1894, page 302, etc.

In 1894 a Recommended Practice for a diamond-truck wheel-base of 5 feet 2 inches was submitted to letter-ballot and was rejected, 548 to 505.

A number of special trucks are still in service and being introduced under new cars. Of these the *Fox solid-pressed-steel truck*, figs. 4578 and 4763-7, is in considerable favor, there being some 12500 or more cars equipped with them on nine roads (see proceedings 1894, page 304); the *Drexel truck*, figs. 4747-50, with which there are 1,100 cars equipped on one road and others on sundry roads, and the *Canda truck*, figs. 4792-4803, of which there are some 3,000 in use on various southern and south-western roads. The *swing-motion caboose truck*, figs. 4750-2, represents an old type of truck that differs from the ordinary *swing-bolster diamond-truck* only in the shape of the arch-bar truss.

For the price allowed for trucks by the rules for interchange of traffic, see *Interchange of Traffic* and *Freight-cars*.

See also *Continuous-frame truck.* *Rigid-bolster truck.*
Swing-motion truck.
Pair of trucks.

3. (English.) American equivalent, *freight-car*. This term is never used in England in the American sense, the word *bogie* being used instead. *Truck* has precisely the same meaning and application as *wagon*, which see. See *Carriage-truck*.

Truck-bearing hinge-casting. 18, figs. 336-42. See *Bearing casting*.

Truck-bolster. 30, figs. 4580-4966. A cross timber or beam in the center of a truck to which the lower center-plate is fastened, and on which the car-body rests. The truck-bolster is connected to the *body-bolster* by a *center-pin* which passes through it. Of truck bolsters there are a variety of forms; the *combination wood and iron* is quite common (figs. 4580-6, 4729-34, etc.); a bolster built of structural l-beams and plates (figs. 4576, 4644-66) is

in favor in this country, and has been recommended by English car builders; the *Sterlingworth*, figs. 4735-9, whose special feature is the use of a channel beam on the top of the bolster, has its advocates, and the *American steel truck-bolster*, fig. 4790-1, was submitted in 1894 to the M. C.-B. Association by its committee on Freight-car trucks as deserving of particular attention. The *Canda freight truck* has no truck-bolster, the body-bolster being supported on V-shaped castings and links, which bear directly upon the springs. The truck-bolster for a six-wheeled truck consists of a frame formed of two timbers at each end, called *spring-beams*, which rest on the springs, and one in the center, called a *truck center-beam*, to which the truck center-plate is attached. All three are united together by iron bars forming a truss or wooden beams. This is represented in figs. 4957-66 and 4961. See *Swing-bolster*.

Truck-bolster chafing-plate (passenger trucks). 36, figs. 4744, 4957. A plate attached to a swing-bolster to protect it from wear.

Truck-bolster fitch-plates. See *Bolster fitch-plates*.

Truck-bolster guide-bars (diamond trucks). 37, figs. 4580-4648. More commonly called *columns*. Cast-iron posts between the *arch-bars*, held in place by *column-bolts*, which form a guide for the end of the bolster. They are not used with trucks which have a swing-motion, and only with rigid-bolster trucks when the latter have bolster-springs, which are universal. These *columns* are sometimes also required to perform the office of *brake hanger carrier*, as in figs. 4735-9. An offset shoulder is cast on the column near the top and on the inside with a jaw to which the brake hanger is fastened by a brake-pin, 87, fig. 4736. Columns are made of pressed steel, fig. 5185, as are the guide-blocks, fig. 5184.

Truck-bolster guide-block. 38, figs. 4580-4648, 4623-5. A cast-iron shoe for the end of a truck-bolster, which slides vertically between the *columns* or bolster guide-bars. They are used only in connection with the latter. See above.

Truck-bolster truss-block. 32, figs. 4745-6. See *Truss-block*.

Truck-bolster truss-rod (rigid-bolster trucks). 31, figs. 4745-6. A rod attached near the ends of a wooden truck-bolster. In swing-bolster trucks, rods of a similar nature are used, and termed *trussom truss-rods*.

Truck-bolster truss-rod bearing. 34, figs. 4745-6.

Truck-bolster truss-rod washer. 35, figs. 4745-6.

Truck center-bearing truss. Figs. 5040-1; 66, figs. 4963-6. The combination of the *Center-bearing arch-bar* and *Center-bearing inverted arch-bars*, which see.

Truck center-plate. 63, figs. 4580-4966. See *Center-plate*.

Truck check-chain eye. 70, figs. 4942-6. See *Check-chain*. A *body check-chain eye* is also used.

Truck check-chain hook. 69, fig. 4942-6. A hook on the end of a check-chain.

Truck details. Figs. 4583-4643, 4649-4723, 4757-4803, 4816-4941, 4967-5373.

Truck end-piece. 17, figs. 4842-4966. See *End-piece*.

Truck-frame. Figs. 4576-4966. A structure composed of wooden beams or iron bars, to which the journal-boxes or pedestals, springs, and other loose parts are attached, and which forms the skeleton of a truck.

Truck-frame corner-plate. 130, 131, figs. 4943, etc., 4964 and 4993-8. A malleable iron or pressed steel plate bolted to the corners of a wooden truck frame to keep it stiff and rigid. They are of recent introduction and take the place of *knee-irons*, which see below.

Truck-frame knee-iron (passenger-car trucks). An interior *angle-plate* of cast or wrought iron to connect the truck-frame together.

Truck-frame queen-posts (wooden freight-car trucks). *Queen-posts* are columns between an upper arch-bar or wheel-act as distance-

Truck knee-iron. See *Truck-frame knee-iron*.

Truck-side. A *truck side-frame*, which see.

Truck side-bearing. 61, figs. 4580-4966. A plate, block, or roller or spring-plate attached to the top of the truck-bolster, on which a corresponding bearing fastened to the body-bolster rests. Their purpose is to prevent the car-body from having too much rocking or rolling motion. They are made of various forms, such as a plain metal plate, to protect a wooden bolster from wear, a *cup-shaped* casting to hold oil or grease and waste, and various forms of *rollers*, *rockers*, studs, spring-cases, and the like. See the names in italics.

Truck side-frame. Figs. 4580, 4644, etc. The longitudinal portion of a truck-frame, on the outside of the wheels, which extends from one axle to the other and to which the journal-boxes and bolsters or transoms are attached. See *Diamond-truck side-frame*, in designating which the term is chiefly employed.

Truck sub-sill. 11, fig. 5654. A sub-sill bolted to the side-sill of a street-car which bears upon the truck frame, to which it is bolted.

Trunnion. The pivot upon which any body, as a gun, revolves. The term is usually applied to bearings for objects of irregular shape, and having slow or irregular motion, as distinguished from the *journals*, of wheels, etc. See *Ladder-trunnion*, 15 and 51, figs. 401-4. *Ladder-trunnion*, 32.

Truss. A frame to which rigidity is given by uniting the parts so that its figure shall be in effect cut up into triangles, making it incapable of distortion by turning of the bars about their joints. The simplest form of truss is that in which a *truss-rod* and *king-post* are put underneath a beam to strengthen it, or two beams are framed together in the form of a letter A, and tied together at their lower ends by a rod or another beam. These are called *king-post trusses*. Another form is that in which two posts are used, which are called *queen-post trusses*. This is not a perfect truss, since it is capable of altering its shape by simply bending without rupturing its parts, when unequally loaded. In order to prevent this, *counter-braces* should be added. This is the usual way of trussing the underframe of cars. The sills resist bending and act as straining beams, thus preventing great distortion. The usual forms of trusses used for the side framing of cars are the *Pratt* and the *Howe* types. In the former all the braces are subject to tension and in the latter the braces are compression members. The *Pratt truss* is rarely used alone to-day for side trussing, but is often used in combination with the *Howe truss*, as shown in figs. 229, 244, 254, 261, etc. The *Howe truss* is rarely used in its simple form, being usually provided with vertical posts alongside of the vertical tension members. Figs. 232, 247 and 251 are examples of such framing. The side of a car is not a perfect truss as ordinarily built, for the middle panel, which contains the door, lacks the essential elements of braces or counter-braces. This is a strong argument for having the side-door of a car at the end, as in fig. 41. The *Howe truss*, without counter-brace, is almost universally used for passenger-car framing. Long cars are re-enforced with heavy trusses of the bridge or roof type such as are shown in figs. 456, 512 and 524, and further strengthened by *body truss-rods*.

The *Challender truss*, which see, figs. 568-9, is a kind of *plate girder*. See *Girder*. See also *Bastard Howe*, *Bastard Pratt*, *Framing*, *Bunk-truss* (of logging cars), figs. 353-4.

Truss-beam (Miller platform). 22, figs. 2290-2. See *Platform truss-beam*.

Truss-block. A distance-piece between a truss-rod and the compression member of a trussed beam, which forms a bearing for both. See *Body-bolster truss-block*, *Trussom truss-block*, *Truck-bolster truss-block*.

Trussed brake-beam. Figs. 4546-99. Nearly all brake-

beams in use to-day are trussed-beams. The usual method is to use a truss-rod from end to end of the beam with a king-post in the middle. The *Detroit* brake-beam is stiffened with a web or plate, and the *Marden* is a plain *deck-beam*. The latter would not be called trussed beams strictly.

Truss-plant (passenger-car frames). 63, figs. 435-73. 537-67. A wide piece of timber bolted to, and sometimes locked into, the posts on the inside of the car immediately above the sills.

A substitute for the truss-plank and body truss-rod is the *Challender truss*, which see, figs. 568-9. The *end truss-plank* is a continuation of the latter across the ends of the car, for uniformity of finish.

Truss-plank cap. 64, figs. 435-73, 537-67. A strip of wood attached to the top of a truss-plank between the seat-frames.

Truss-rod. 1. An inclined rod used in connection with a king or queen-post truss, or trussed beam, to resist deflection. It is attached to the ends of the beam, and is supported in the middle by a *king-post*, *truss-block*, or two *queen-posts* between the beam and the rod. A substitute for the body truss-rod, as well as for the truss-plank and body brace-rods of an ordinary car-frame, is the *Challender truss*, fig. 185*b*, which see. Various forms of truss-rods are the following, which see:

- Body-bolster truss-rod.* *Derrick truss-rod.*
- Body truss-rod (center and outside).* *Hand-car truss-rod.*
- Brake-beam truss-rod.* *Inverted body truss-rod.*
- Cross-frame, or needle-beam truss-rod.* *Overhang truss-rod.*
- Platform truss-rod.*
- Safety-beam truss-rod.*

2. (Cabin of pile-driver car.) 37, fig. 401-4. Oblique rods parallel with the braces, connecting the swinging-platform sills with the top-stringers.

Truss-rod anchor-iron. 24, figs. 435-73, etc. A wrought-iron strap with lugs and a turn at the end which engage with the iron body-bolster and in recesses cut into the side-sill, to which it is bolted. It serves as an anchor to attach the ends of the body truss-rods to the side-sills.

Truss-rod bearing. A bearing used to furnish support to a truss-rod, at an angle or bend in the latter, as

- Body truss-rod bearing.*
- Body-bolster truss-rod bearing.*
- Truck-bolster truss-rod bearing.*

The bearing over the bolster of a long body truss-rod running from end-sill to end sill is called a *body truss-rod saddle*, probably in part from its form. A distinction has been attempted between a *truss-rod bearing* and a *truss-rod saddle*, founded upon the direction of the strain which it resists, and this distinction has been preserved in this edition. It cannot, however, be said to be founded on usage, either of bridge builders or car-builders, except in respect to the *body truss-rod saddle*, as above stated.

Truss-rod iron. 24, figs. 435-73. A bar of iron, having an eye, to which a *body truss-rod* is attached, bolted to the under side of a sill below a body-bolster. It is a form of attaching body truss-rods almost out of use for freight-cars, but in common use on passenger-cars. A *truss-rod anchor iron*.

Truss-rod queen-post. (Street-cars.) 16, figs. 5654-67. See *Truss-rod*.

Truss-rod saddle. See note to *truss-rod bearing* and *body truss-rod saddle*, 20, figs. 229-66.

Truss-rod washer. A large flat or beveled washer, used under a nut on the end of a truss-rod. Sometimes called a *skew-back*. See *Body-bolster truss-rod washer*, *Truck-bolster truss-rod washer*.

Tubed oil-screws. Figs. 3385-6. See *Oil-screws*.

Tubular car. A form of car construction, introduced some years ago, in which the sills and floor-framing are built of iron gas-pipe. A large number of these cars have been built and are in service under leases on the smaller roads. They were built at a time when the demands upon cars were rapidly increasing and they were not equal to the burdens and rough treatment to which they were subjected. They grew in disfavor owing to the fact that the repairs were expensive and

arduous, probably because car repairers were not iron-workers or pipe-fitters, as well as the difficulties attending the repair of distorted parts. Few, if any, have been built lately.

Tubular lantern. A lantern having no guards except a rectangular frame of tubes through which the air-supply is also carried. They are in two forms, with *shade reflector* and *square or side reflector*.

Tufting button. Figs. 3645-6. A button used in upholstery to hold the cord which passes through the upper covering of the upholstered surface, dividing it up into squares or diamonds.

Tumbler. 1. A drinking-glass.

2. (Foundry.) A machine for cleaning castings, locomotive tubes, etc. It consists of a case mounted on a shaft on which it is made to revolve. The articles inside of the case are cleaned by their attrition against each other and the case.

3. (Locksmithing.) 2, figs. 2766-7. "A latch engaging within a notch in a lock, bolt, or otherwise, opposing its motion until it is lifted or arranged by the key so as to remove the obstacle."—*Knight*.

Tumbler-dog (Miller's padlock). C, fig. 2770. A catch to hold the hasp locked except when it enters the tumbler.

Tumbler-holder. Figs. 3495-3501. A bracket or stand for holding glass tumblers or drinking cups. They are either *single* or *double*.

Tumbler-holder and drip. Fig. 3473. A water-cooler drip, the top of which is made large enough to hold a glass.

Tumbler-spring (Miller's padlock). F, fig. 2770.

Tunnel velocipedes. Figs. 5617-19. See *Mine and tunnel velocipedes*.

Turnbuckle. Figs. 3725-27*a*. A device inserted in the middle of a long rod for changing its length. *Right and left screw* turnbuckles, fig. 3727*a*, or *single screw* turnbuckles, fig. 3725, are the most common; *pipe* or *tube* turnbuckles, fig. 3727, are rarely used.

A form that has gained much favor for use on cars is that shown in fig. 3727*a*, the *Kimball's pressed wrought iron turnbuckle*. They are made the following sizes, and larger in proportion:

SIZE D.	A	B	C	L
1 Inch.	6 In.	1 1/4 In.	9 In.	25 In.
1 1/8 "	6 "	1 1/2 "	9 1/2 "	25 "
1 1/4 "	6 "	1 3/8 "	9 3/4 "	26 "
1 1/2 "	6 "	1 1/2 "	10 1/4 "	27 "
1 3/4 "	6 "	1 5/8 "	10 1/2 "	27 "
1 7/8 "	6 "	1 3/4 "	10 3/4 "	28 "
1 3/4 "	6 "	1 7/8 "	11 1/4 "	28 "

- D. Size=Outside Diameter of Screw.
- A. Length in Clear between head=6 in. first length for all sizes.
- B. Length of Tapped Heads=1 1/4 D.
- C. Total Length of Buckle without Bolt Ends.
- L. Total Length of Buckle and Stub ends when open.

The letters refer to dimensions shown in fig. 3727*a*.

Turn-under (English). See *Fall-under*.

Turtle-back roof. Figs. 95-6, and 112. A roof for a passenger-car which is arched, but without a clear story or upper deck. It is the prevailing roof for English carriages, but has not found favor in this country, its use being confined chiefly to the Mann boudoir cars and to a few coaches on the Boston & Albany Railroad.

Twelve-wheeled car. Figs. 27, 332-5. An ore car with three 4-wheeled trucks, one under each end and one in the middle. See *Center-truck*, etc.

Twin car-seat. Figs. 3924 5, 3955, 3974-6, 3981. A seat stand with a division arm, two cushions, two seat-backs with two striker-arms each, so that they may be turned so as to bring the occupants face to face. There are two types of these seats, one illustrated by figs. 3955-3976 and 3981, and the other by figs. 3922, 3924-5, and 3974-5, which differ from the other in being adjustable

to a reclining position, and being provided with leg and foot rests. The latter are a substitute for the *Hartley* and *Hitchcock* reclining chairs, figs. 3996-9.

Twin door-panels. 10, fig. 1788. A pair of panels side by side in a door, formed by inserting a *parting-rail* into a wide panel.

Twin-hopper gondola-car. Figs. 26, 69, 310-20. A gondola car with two hoppers, the centers of which are about 10 feet apart. This type of gondola has been adopted to get a long flat-bottomed car that will discharge its contents with the least amount of shoveling. The car may also be used for long timber. See *Gondola*.

Twin-washer. Fig. 3719. A *double-washer*, which see.

Twin-window. Fig. 124. Two small and rather narrow windows placed side by side. The tendency is to abandon the use of all such irregular forms, except in *dining-cars* or *private cars*, where the partitions and closets seem to require it, as in figs. 101 and 104.

Twisted flat wire (for car seals, which see). Fig. 3900. A form adapted to prevent the possibility of the lead seal being stripped from the wire and afterwards replaced upon it.

Two-group spiral springs. 18, figs. 5226-8. See *Spiral springs*.

Two-horse street car. The most common form of *horse car*, which see.

Two-light center-lamp. Figs. 3261-72, and 3313-15. See *Center-lamp* and *chandelier*. The majority of center-lamps are two light burners.

Two-spring slip-burner. Fig. 3370. See *Slip-burner*.

Tyler-brake (street-cars). A simple form of brake-gear for applying outer-hung brakes from either platform. The pressure upon the brake-beams is not equal.

Tyre (of a wheel). See *Tire*.

The spelling "tyre" is the English method and corresponds with the supposed origin of the word, which is from the fact that iron bands were first used on wheels in the city of Tyre, Syria.

U

U-bolt. 1. Fig. 3713. A double bolt made of a bar of iron, bent in the shape of the letter U, with a nut and screw on each end. See *Brake-hanger carrier*. *Stake-pocket U-bolt*.

2. (Janney coupler.) 144, fig. 2301.

U-hanger. A U-shaped strap fastened over the end of a half-elliptic spring. See *Spring-hanger*. A T-hanger is one with a T-headed bolt passing through a slot in the end of the spring. Not used in car construction.

Umbrella holder and pocket. Figs. 3693-4. A bracket with oval holes, put up in a horizontal position with the pocket a suitable distance below it. The umbrella is thrust through the bracket, the end resting in the pocket below.

Umbrella-rest (for cuspidor). Fig. 2863. Small tubes used in connection with cuspidors having large mats, as a means for holding umbrellas upright for drainage.

Uncoupling-chain (Miller coupler). 16, fig. 2292. See below.

Uncoupling-lever (Miller coupler). 1. 15, fig. 2292. A lever attached to the platform of a car, and connected by the *uncoupling-chain* with the coupling-hook or knuckle-lock, to disengage or uncouple it from the one on the adjoining car. It is fulcrumed in an *uncoupling-lever trunnion-plate* fastened under the platform end-timber, and passes through a hole in the latter, which is reinforced above by the *uncoupling-lever plate*. The *uncoupling-lever wedge*, attached to the platform by the *uncoupling-lever wedge-chain*, is inserted in this plate to hold the lever in either one of its extreme positions. An *uncoupling-lever ratchet* on the platform railing holds the lever in any desired position.

2. 16, fig. 2292. A lever attached to the end of the uncoupling-

3. (Freight-cars.) An uncoupling-lever and rod usually attached to the end sill by which the lock of the M. C. B. coupler is opened and the cars uncoupled without going between them. The lever and rod is in various forms, as the form of lock may require.

Uncoupling-lever plate. 18, figs. 2290-2. See above.

Uncoupling-lever ratchet. 17, figs. 2290-2. See above.

Uncoupling-lever trunnion-plate. 21, figs. 2290-2. See above.

Uncoupling-rod. 210, figs. 441, etc. A rod connecting the uncoupling-lever with the lock of an automatic-coupler. On freight-cars it is forged in one piece with the lever.

Uncoupling-shaft stirrup. Figs. 1317-18.

Under-frame. A stout framework chiefly composed of timber, which receives the buffing and drawing strains, and carries the weight of the floor and body of the vehicle. In both freight and passenger-cars in America the under-frame and body are rigidly connected and mutually stiffen and strengthen one another, but in English carriages the body is framed as an independent structure, and merely rests on the under-frame, rubber pads (*India-rubber body-cushions*) being interposed to deaden shocks. The only connection is through a *body holding-down bolt*, which see. Under-frame is an English term, but it is so general in this country that it may be said to have been adopted. It includes all the framing below the floor, and includes the platforms, draft-timbers, etc.

Under-frame plate (English). See *Spider-plate*.

Under-hung door. A sliding door which is supported and slides on a rail below the door. *Over-hung doors* are preferred.

Union (pipe-fittings). A *union-joint*, which see.

Union-joint (pipe-fittings). A means of uniting the ends of two pipes with a nut. The latter is attached to one pipe with a collar, and is screwed on the opposite pipe, or on a thimble attached to the pipe. Often called simply a *union* or *coupling*. They are largely used for all forms of pipe-work, and take their distinctive names, if any, from the parts with which they are connected, as *drain-pipe union*, *reservoir union*, etc., of Westinghouse brake.

Union-gasket. (Triple-valve.) 27, figs. 1706-7. See *Gasket*.

Union-nut. (Triple-valve and air-pump.) Figs. 1691-2, 1706-7.

Union-stud. (Triple-valve and air-pump.) Figs. 1691-2, 1706-7. See *Stud*.

Union-swivel. (Triple-valve and air-pump.) Figs. 1691-2, 1706-7. See *Swivel*.

Union tank-line draft-gear. Figs. 2031-3. The essential features of this gear are that the draft-timbers are between the center-sills and extend below the sills. The draft timbers are secured to the center-sills by key-stones, 1 x 3 inches, let into the draft-timbers and the sills equally. The draw-bar attachment shown is the Butler attachment, with tail-bolt. The spring pocket yoke or strap has lately been adopted as standard with this company.

"Unique" sun-hinge burner. Fig. 3377. See *Sun-hinge burner*.

United States standard system of screw-threads. This term is often used to designate the *Sellers system of screw-threads*, which see.

Universal steel brake-beam. Figs. 1599, 4862-71, 4899. A steel brake-beam of the tubular form, with a slit upon one side, and which is trussed by a rod and king-post. A special feature is the swivel king-post by which the *brake-lever* may work at any angle, or be reversed so that the brake-lever may be used either as right or left.

Universal joint. 1. "A device for connecting the ends of two shafts so as to allow them to have perfect freedom of motion in every direction within certain defined limits."—*Knight*. An application in car-building which

- has not yet secured general use is as a substitute for brake-hose, in connection with air-brake and steam apparatus.
- Universal shade-ring.** Fig. 3437. A shade-ring, which see, so constructed as to be of adjustable diameter.
- Upholstery.** In passenger-car construction, the cushions, curtains, carpets, beds, etc., and generally the materials from which they are made.
- Upholstery details (of seats).** Figs. 3923-4013. See also *Sleeping-car furnishings and details*.
- Upper air-cylinder gasket (air-pump).** 38, fig. 1689; 103, figs. 1691-2. See *Gasket*.
- Upper-bearing.** See *Swing link-hanger*.
- Upper belt-rail (passenger-car exteriors).** 82, figs. 435-73. A horizontal bar attached to the posts on the outside and above the windows.
- Upper-berth.** 2, figs. 2409-12. The top berth in a sleeping-car section. It folds up by day against the roof, being secured by a *berth-latch* or *safety berth-latch*, having a pocket above it in which the head-board, two thin mattresses and the bedding are stored. See *Berth*. In the Mann boudoir cars, the upper berth, **B**, fig. 2418, is the sofa-back by day.
- Upper-berth bracket.** Fig. 4169. A form of *upper-berth rest* closely resembling a bracket.
- Upper-berth curtains (Mann boudoir car).** 12, fig. 2418. See *Berth-curtain*.
- Upper-berth hinge (Mann boudoir car).** **F**, fig. 2418. A hinge at the top of the sofa-back by which the latter is lifted up into position to form the upper berth. The outside edge is supported on the *upper-berth rest*, 12, fig. 2418.
- Upper-berth pocket.** A pocket against the sides of the car which closed up flush therewith when the upper berth was folded up, but dropped open when the berth was made up, so as to afford a receptacle for clothing and baggage. It has been replaced by a *hammock*. Similar pockets for the lower berth are made by turning up the head-rest of the seat.
- Upper-berth rest.** 1. (Sleeping-cars.) Fig. 4156. A metal lug, or shelf, which supports an upper-berth when lowered.
2. (Emigrant sleeping-cars.) **L**, figs. 2413-14, 42-59-60. An attachment for leaving the upper-berth partially open by day for ventilation. Another upper-berth rest **M** is attached to the *berth-post*.
- Upper-berth rest (Mann boudoir cars).** 12, fig. 2418. See *Upper-berth hinge*.
- Upper-berth rest-pivot.** Fig. 4188. A pin attached to a plate fastened to an upper-berth. The pin engages in a hole in a *berth-rest*, which see.
- Upper-berth rest-plate (Mann boudoir-cars).** 11, fig. 2418. A plate permanently fastened to the window-frame to carry the *upper-berth rest*.
- Upper-bolster plate.** 12a, figs. 435-73. Should read *Body-bolster top-plate*. See *Body-bolster*.
- Upper brake-shaft bearing.** 96, figs. 229-66. An eye by which the upper end of a brak shaft is held in place. In passenger and street cars, usually attached to the hand-rail; on freight box-cars, when the brakes are operated from the roof, to the end of the body near the top.
- Upper-cap (triple-valve of Westinghouse air-brake).** 4, figs. 1708-9.
- Upper corner-plate.** 55, figs. 229-66. See *Corner-plate*.
- Upper (or top) cylinder-head (Westinghouse driving-wheel brake-cylinder).** 5, fig. 1748. See *Cylinder-head*.
- Upper deck (passenger-cars).** 110, figs. 435-73, etc. Also called *clear-story*. The raised central portion of the roof. See *Deck*.
- Upper-deck bottom-rail (street-car).** The *deck-sill* or *sill* of a *clear-story*.
- Upper-deck car-line.** 118, figs. 435-73. Carlines, which see, passing from side to side of the upper deck only, resting on the *deck-plate*. Usually called simply *deck carline*.
- Upper-deck eaves-molding.** 119, figs. 435-73. A molding, usually called simply *deck eaves-molding*, on the outside edge of the roof.
- Upper-deck furring-strip.** 58a, figs. 5654-67. See *Furring*.
- Upper diaphragm case (signal-valve, train-signal apparatus).** Fig. 2404. See also *Diaphragm*.
- Upper discharge-valve (air-pump).** 30, fig. 1689; 86, fig. 1691. A puppet-valve at the top of the air-pump cylinder through which the compressed air above the piston passes.
- Upper door-hinge (English).** 178, fig. 501. See *Door-hinge*.
- Upper door-sash.** 12, fig. 1788. The part of a double window-sash in a car-door which covers the upper part of the opening. This upper section is usually made movable, so that it can be lowered for ventilation.
- Upper end-panel (street-cars).** See *Panel*.
- Upper-floor (stock-car, which see).** 28, figs. 3558-9. More commonly, *double-deck*.
- Upper-platform (pile-driver car).** 27, figs. 401-4. The floor of the *swinging-platform*, which see. See also *Pile-driver car*.
- Upper receiving-valve (air-pump).** 31, fig. 1689.
- Upper-rail (sliding-doors).** Usually called *top door-rail*. A guide-rail above doors which are supported upon rollers at the bottom, or one carrying a door suspended upon *door-hangers*. See *Door-rail*.
- Upper seat-back rail.** See *Seat-back*.
- Upper steam-cylinder gasket (air-pump).** 36, fig. 1689; 101, figs. 1691-2. See *Gasket*.
- Upper steam-valve (air-pump).** 7, fig. 1689. See *Main steam-valve*. The upper steam-valve is smaller than the lower.
- Upper steam-valve bushing (air-brake).** 25, fig. 1689. See *Bushing*.
- Upper swing-hanger pivot.** 47, figs. 4740-6. See also *Lower swing-hanger pivot*.
- Upper valve-chamber cap (air-pump).** 29, fig. 1689.
- Upper wainscot end-rail (passenger-car interiors).** See below.
- Upper wainscot-rail.** A longitudinal wooden bar or rail, fastened to the posts immediately under the window. 75, figs. 539-567. See *Wainscot-rail*.
- Upper window-blind.** See *Window-blind*.
- Upper window-blind lift.** Figs. 4435-7, etc. Distinguished from a *lower window-blind lift* in not having a lug or ledge. See *Window-blind lift*.
- Upper window-panel rail.** 98b, fig. 558.
- Urinal.** 132, fig. 448, and figs. 3871-6. A metal or porcelain receptacle used in saloons, connected to a pipe leading through the floor. They are distinguished as *corner* or *side* urinals, the former almost invariably used in car work. A *concealing* urinal, which see, shutting up flush with the wood work when not in use, is sometimes used.
- Urinal-cover.** A wooden or sheet-metal lid for inclosing a urinal.
- Urinal-drip, or drip-pan.** Fig. 3873. A pan under a urinal on the floor.
- Urinal-pipe.** See *Urinal*.
- Urinal-handle.** Figs. 3844-9. A handle in a saloon, placed above the urinal to hold on to. They are distinguished as *corner* or *side urinal-handles*, according to their position on the side of the car.
- Urinal-safe (parlor-car water-closets).** Figs. 5338-9. A plate covering the top of the bowl to prevent nuisance in the inclosed parts.
- Urinal-Ventilator.** A pipe attached to a cap on a urinal, communicating with the top of a car, where some form of *wind-scoop* is often added.

V

Vacuum-brake. Figs. 1661-8. A system of continuous brakes which is operated by *exhausting* the air from some appliance under each car by which the pressure of the external air is transmitted to the brake levers and shoes. So called in distinction from *air-brakes*, which see, which are technically understood to refer only to brakes operating with compressed air, although in a literal sense the vacuum-brake is also an air-brake. An *ejector* on the engine is ordinarily used for exhausting the air, connected with the rest of the train by pipes and flexible hose between the cars. The vacuum brake in common use in this country is the *Eames vacuum-brake*, which see, and this only to a limited extent.

Valance. A term applied to the tasselled decorations of windows and which cover and conceal the shade roller and curtain holder. **B**, fig. 2453.

Valve. A lid, cover, or plug for opening and closing an aperture or passage.

See *Check-valve*.

Conductor's valve.

Coupling-valve.

Discharge-valve.

Double check-valve.

Lower discharge-valve.

Lower steam-valve.

Receiving-valve.

Receiver filling-valve.

Receiver-valve.

Register-valve.

Reversing-valve.

Safety-valve.

Signal-valve.

Slide-valve of triple-valve.

Steam-valve.

Tank-valve.

Throttle-valve.

Top-plate valve.

Triple-valve.

Upper discharge valve.

Upper steam-valve.

Ventilator-valve.

Water-cooler valve.

Valve body. The shell case or frame of a valve. See *Triple valves*, figs. 1706-7, 1708-9. *Engineer's valve*, figs. 1710-15. *Pump governor*, fig. 1716, etc.

Valve-chamber-bush (air pump). **43**, fig. 1689.

Valve-key (Pintsch gas-lighting apparatus). Figs. 3214-15. A key for opening all the high-pressure valves, the *lamp-key*, fig. 823, being used for the low-pressure valves connected with the burners.

Valve-knob (Eames dividing attachment). **62**, fig. 1682. The knob for operating the valve.

Valve-seat. "The flat or conical surface on which a valve rests."—*Knight*. See *Discharge-valve seat*. *Tank-valve seat*.

Valve-stem. A rod attached to a valve, and by which the latter is moved, is always called a *valve-stem*. See *Eames dividing attachment*, **63**, fig. 1682. *Howard's parlor-car water-closet*, figs. 3838-9. See also *Reversing-valve stem*.

Van (English). A comprehensive term for any covered vehicle not used for conveying ordinary passengers or ordinary freight. See *Brake-van*. *Bullion-van*. *Guard's van*.

Van Dorsten car-coupler. Freight, figs. 2240-3; passenger, 2275-6.

Van Liew grain-door. Figs. 1866-9. One of the numerous devices for speedily removing and returning to place a grain-door. It consists principally of *stanchion guide-rod*, **F**, standing in the *guide-rod socket* generally, on which a *stanchion*, **3**, attached to a *stanchion socket*, **2**, freely slides. The latter is attached to the grain-door. The door is locked into place by the *lug* **I**, confining it to the *grain-door guide* **O**. When not in use it is confined in a vertical position by the *floor-stop* **g**, and the *side-stop* **H**.

Varnish. A "liquid-glass" for covering paint or wood-work. See *Finishing varnish*.

Vauclain steel-tired wrought-iron spoke-center wheel. Figs. 5314-15.

Velocipede-car. Figs. 5605-49. Generally a three-wheeled car in which the rider sits astride and propels the car with his feet (or feet and hands together), after the manner of a velocipede. They comprise a variety of pairers, lamp-

Veneer. "A thin leaf of a superior wood for overlaying an inferior wood."—*Webster*. By trade usage it is a veneer if it covers other materials than inferior wood. Thus in the Spurr veneers and wood carvings, figs. 3660-3, the material covered is a matrix resembling *papier maché*. It may be in relief, resembling wood carvings. See *Ceiling veneers*. *Perforated veneers*.

Vent. "A small aperture; a hole or passage for air or other fluid to escape."—*Webster*. See *Lamp-vent*.

Ventilated box-car. Figs. 5, 257-62. A box-car with grated doors and screened openings called ventilators, through which the air can circulate freely. Used chiefly for fruit.

Ventilating jack (for saloons). **V'**, fig. 539; **130a**, fig. 444. Also called *wind-scoop*. A flaring horizontal tube, constituting a simple form of the ventilating devices which use the current produced by the motion of the cars to cause an exhaust current of air. See *Wind-scoop*. *Injector*, etc.

Ventilator. 1. Figs. 4299-4329a. A device for admitting or exhausting air to or from a car. Ventilators, according to their position, are designated as *deck ventilators* (end or side), *end ventilators*, *frieze ventilators*, etc. They are often designated as *automatic* or *self-acting*. The prominent forms of the latter varieties are shown in figs. 4300-24. See also the various wind-scoops shown with car-heaters and saloon furnishings, figs. 4327-9a, 3058-60. An exhaust-ventilator, for saloon-hoppers, attached to the under side of cars (*Bell's exhaust*, which see), is shown in figs. 3841-2. Ventilators for boarding-cars, tool-cars, work-trains, etc., are also put in the floor, a trap-door being placed there provided with gratings underneath. Among the ventilators in use are the *Eureka* and *Automatic*, the *Globe erect*, fig. 4312; *Globe horizontal*, fig. 4313; *Creamer eureka*, fig. 4314; *Creamer automatic*, fig. 4318; *Cone-cap*, fig. 4302; *Cone and apron*, fig. 4303; *Canopy*, fig. 4304; *Tornado*, fig. 4299; *Tornado canopy*, fig. 4305; *Dished cap*, fig. 4306; *Moore*, fig. 4307; *Duplex*, fig. 4308; *Roe*, fig. 4309; *Stasch*, fig. 4310; *World*, fig. 4815; *Torpedo*, fig. 4316; *Star*, fig. 4311; *Deflector*, figs. 4317-17a; *Double duplex deflector*, figs. 4323-4; *Continuous duplex deflector*, figs. 4321-2; *Small duplex deflector*, figs. 4319-20, which see. The proper system of ventilation for passenger-cars is still a mooted question. The supply of air required for each person, for good ventilation, is at least 22 cubic feet per minute.

The ventilation of the Pullman cars is very elaborate, and perhaps the most perfect now in use. No air is intended to be admitted within the car by the windows or otherwise, except through an in-take or wind-scoop. The air thus collected is forced downward into a duct or conduit containing hot-water pipes, under the seats and into the car through a register in the seat-end. The air escapes through the deck-windows. Saloons are ventilated by separate exhaust ventilators, and the hopper and urinal are provided with vent-pipes. Suction ventilators applied to the deck-windows or between them are used to exhaust the air, thus keeping up a continual circulation. Day coaches usually depend upon the deck-windows for ventilation, the sash at every other window being hung on different sides, so that the open sash may be hinged on the front end. Sash openers for deck-sash hinged in this manner are shown in figs. 4330-2, 4338 and 4349. The question of ventilation of cars is an important one and must receive the attention it merits. For a report of tests with the various ventilators shown see *Proceedings M. C. B. Association*, 1894, page 234.

2. (For fruit-car.) Figs. 257-66. A system of slats protected by netting at each end of the car, so arranged as to enable the ventilators to be readily opened or closed from the outside.

3. (Spear heater.) Figs. 3058-60. A large wind-scoop. **Ventilator-arm.** A small attachment carried on deck-sashes, especially of street-cars, for holding them open.

Ventilator-cap (for urinals). Fig. 3875.

Ventilator-casing (street-car). 158, fig. 5654-67. The casing of the side ventilators, or *deck windows*, which takes the ventilator-sash, or to which the wire-screen is fastened.

Ventilator-cowl (English). See *Ventilator-hood*.

Ventilator-deflector. Figs. 4317-24. A metal plate or board placed in such a position at a ventilator opening that it will cause a current of air to flow into or out of the car when the latter is in motion. Another form, used in windows to produce an exhaust draft when opened, is a mere loose board with a notch to receive the lower edge of the window-sash, figs. 4527-30. See *Deflector*.

Ventilator-door. A door for closing the aperture of a ventilator. See also *Ventilator-valve*.

Ventilator fixed-panel (English). 136, figs. 501-4. The outer panel in a ventilator composed of two perforated panels, one being capable of being slid over the other so that the perforations coincide or become covered. This form of ventilator is used in English cars to the exclusion of any other. See also *Ventilator-hood* and *ventilator sliding-panel*.

Ventilator-hood. 1. 2, fig. 1569. A shield over the outside of a ventilator to prevent the entrance of sparks, cinders, rain or snow. It is sometimes intended to direct the current of air either into or out of the car. See also *Deck end-ventilator hood*.

2. (English.) 134, figs. 501-4. Also called *ventilator-cowl*. A shield made of either wood or metal, preventing the entrance of rain or cinders.

Ventilator-netting. 1. A wire screen or netting fastened over the outer deck window-sash to prevent the entrance of sparks, cinders and dust.

2. A netting over the ventilator windows of a fruit-car.

Ventilator-opener. See *Deck-sash opener*, figs. 4330-41, 4349.

Ventilator-panel. A panel in the frame of a valve or door for closing the aperture of a ventilator.

Ventilator-pivot. A pin on which a ventilator door or sash is swung or hinged. It is the same as a *deck-sash pivot*, fig. 4357-64.

Ventilator pivot-plate. The same as a *sash-lock plate* or *stop*, fig. 4356, etc.

Ventilator-plate. See *Frieze ventilator-plate*.

Ventilator-register. Fig. R, fig. 4329 and fig. 4326. A metal plate or frame attached to a ventilator opening, provided with slats arranged so as to turn and thus either open or close the ventilator. They are chiefly used as *frieze-ventilators*, but sometimes elsewhere. In sleeping-cars they are sometimes combined with berth curtain-rod brackets.

Ventilator-sash. 116, figs. 435-73. Usually a *deck-sash*.

Ventilator-sash pivot. A *deck-sash pivot*.

Ventilator sliding-panel (English). 135, figs. 501-4. Part of a ventilator in which there are two perforated hard-wood slides, the outer fixed, the inner movable, so as to make the perforations coincide or be covered. See *Ventilator-hood* and *ventilator fixed panel*.

Ventilator-staff. Fig. 4376-80. A *pull-hook* or *deck-sash opener*.

Ventilator-stop (street-car). A small metal bracket on which a ventilator-sash rests when open.

Ventilator-valve. 116, figs. 435-73. A door for opening or closing the aperture of a ventilator, usually made to turn on pivots at or near its center. See *Deck-sash pivot*.

Vertical equalizing-lever. 25, figs. 2437-45. (Pullman vestibule.) A vertical lever, one end of which bears against an *Overhead face-plate buffing-spring* (called an *Overhead-equalizer spring*) and the other end against the *horizontal equalizing lever*, the middle of which is

pivoted by a bracket attached to a longitudinal plate or bar that abuts against the *body end-plate*. The object of these *vertical equalizing-levers* is to get the horizontal equalizer-lever high enough to give head-room in the vestibule for the dome lamp, etc.

Vertical steam-trap and blow-off (Gold's car heating). Fig. 3004. A *thermostatic steam-trap*, which see, and a blow-off valve combined. It may be operated from inside of the car. The names of parts and their office is given in the list of names with the figs. 3011-12.

Vertical telegraph cock, or faucet. See *Telegraph cock*.

Vestibule. 1. (Of a car.) Formerly that part of the car nearest the door, cut off from the main saloon by an interior door. It was occupied by the saloon, washing and heating arrangements, etc. Its purpose was to give protection to the interior of the car against drafts and noise.

2. Figs. 2419-48. Usually a platform enclosure, consisting of a *face* or *buffer-plate*, constituting an arched doorway, connected with a spring extended rod, a *foot-plate* combined with the *buffer-stems* and *face-plate*, a bellows-like connection called a *diaphragm* between the *face-plate* and car frame and *side-doors* opening to the steps. The successful application of the vestibule to cars was first accomplished by the Pullman's Palace Car Company. It was patented April 29, 1887, by H. H. Sessions, and assigned to the P. P. C. Co. It claimed the invention of "the combination with the end of a railway car of a frame plate or equivalent series of buffers backed by springs, arranged with its face in a vertical plane and normally projecting beyond the end of the car, whereby, upon the coupling of two cars a spring buffer will be interposed between the superstructures of such adjacent cars above their platforms, and also *frictional surface opposing spring pressures* to prevent the racking of the car frames upon sudden stoppages and to oppose the tendency of the cars to sway laterally [oscillate] when in motion," so arranged and adjusted that "when the two cars were coupled the faces of the buffers will bear against each other in contact under pressure."

The courts have upheld the validity of the patent on the grounds that "the device possessed patentable novelty and utility." The claims sustained were those of "frictional contact of the face plates under constantly opposing spring pressure, which diminished the shock to the superstructure in collisions and resisted the forces tending to create oscillation." The frame plate of the original vestibule was to have longitudinal motion, but *no lateral motion* except with the car body. The use of the canopy feature was old, for it had been in use for more than 20 years in England, Russia, and the United States.

The additional cost of the application of the vestibule feature to a new car is from \$700-\$1,000, depending upon the decorative features specified.

Vestibule (composite) end-post. The end-post of a vestibule, resting upon the *platform end-sill*. In the *Pullman*, figs. 2437-9, and *Wagner*, figs. 529-30, cars it is a *composite end-post* composed of an iron-bar or angle-bar bent at the ends and bolted to the platform and *platform-hood end-carline*. It is stiffened with wood bolted to the sides of the bar or angle-bar.

Vestibule body-corner-post. L, figs. 529-30, and figs. 2442-3, 2427. The inner-post of a vestibule, set against the end of the car body and directly over the platform sills.

Vestibule buffer-plate. 29', figs. 539-41; 8, figs. 2442-5. An extra long and wide buffer-plate, recessed or chamfered at the ends to take the face-plate of the vestibule, whose face is flush with the buffer-plate.

Vestibule dome-lamp. 22, figs. 2425-45; figs. 3239, 3241, 3278-9. A lamp specially designed for vestibules.

Vestibule-door. Figs. 1789-91. A door by which the vestibule of a car is entered from the side. In the older

type of vestibule they are double or divided, the two doors being hinged together and to the *vestibule corner-post*.

Vestibule door-bolt or latch. Fig. 2553a-b. See *Door-bolt*.

Vestibule door-hinge. 1. Strap hinges, figs. 2603-4, which fasten the double doors of a vestibule together.

2. For rabbeted doors, fig. 2609.

Vestibule door-latch. Figs. 2637-8. A door-latch specially designed for vestibule doors. A mortise latch is shown in figs. 2706.

Vestibule door-rod. 24, fig. 1790, figs. 3780-3. A bar or rod across the vestibule doors to prevent their being pushed in.

Vestibule end-carline. 35, figs. 2425-48. A *Platform-hood end-carline*.

Vestibule face-plate. An inverted U-shaped forging about the side of a door frame arched at the top, and forming a passage way from the platform of one car to that of the next. The weight of it is carried on the buffer-plate; it is kept thrust out against the opposing face-plate either by springs, as in the Pullman *vestibule*, or by its own weight, as in the Barr and Wagner *vestibules*.

Vestibule-gate (Pullman). Figs. 2449-50. A gate to the arched doorway, leading from the platform of one car to that of the next car.

Vestibule-hood. 19, figs. 2425-45. A platform hood.

Vestibule-lamps. Figs. 3135, 3140, 3239, 3241, 3278-9. See *Frost lamps, Pintsch lamps, etc.*

Vestibule platform trimmings. Figs. 3771-2.

"**Vienna**" lamp-shade. Fig. 3427. See *Lamp-shade*.

Volute spring. Fig. 5244. A spring made of a flat bar of steel coiled with a kind of scroll resembling the volutes used as an ornament in the capitals of ancient Roman and Grecian architecture. The coil is made in a conical form, so that the spring can be compressed in the direction of the axis around which it is coiled. They are now little used in this country, but largely in Europe.

V-shaped screw-thread. Fig. 5495. A thread with a sharp edge at the top and sharp groove at the root. The Sellers (U. S.) standard thread, fig. 4497, is flat at the top and at the root, and the Whitworth, fig. 5496, is rounded at those points. V-threads are now used chiefly for pipe-threads.

Vulcanized fiber. A leathery material of great durability and toughness, which is made by subjecting various kinds of vegetable fiber to the action of acids. It is insoluble in all ordinary solvents, such as oil, alcohol, ether, ammonia, etc. It is made in two classes, *hard* or *flexible* (the former being that used generally in car construction for the dust-guards of journal-boxes), fig. 5154, and in sheets from 16 to 24 in. wide by about 50 in. long and from $\frac{1}{32}$ in. to $\frac{1}{4}$ in. thick. Another name for the same article is *gelatinized fiber*.

V window-button. Fig. 4458. A catch, with a V-shaped notch in the end, fastened to a window-post to hold up a window. Little used.

W

Wabash hand-car for inspectors. Figs. 5592-4, gives full details and dimensions.

Wadley continuous drawbar. Figs. 1936-9. A *continuous drawbar* (which see) is merely an elongated tail-bolt with a *turn-buckle* in the middle of the car to join it to the tail-bolt from the other end of the car.

Wagner car-door. Figs. 1794-1806. A flush car-door, the front side of which is carried in by bending the door-track in close to the car-side and the rear side is forced in flush by an eccentric lever and rod, shown in figs. 1801-6.

Wagon, or goods-wagon (English). Figs. 348-51. American equivalent, *freight-car*. A vehicle (always four-wheeled, but sometimes six-wheeled) for carrying merchandise, minerals, etc. *Truck* is

See *Ballast wagon.**
*Bullock wagon.**
*Boiler wagon.**
Box wagon.
Cattle wagon.
Covered wagon.
Goods wagon.

*High-sided wagon.**
*Low-sided wagon.**
*Medium-sided wagon.**
*Open wagon.**
*Rail wagon.**
*Timber wagon.**

Wagons marked thus * are *open wagons (gondola-cars)* having no roof.

Wagon-coupling, or draw-chain (English). 41, 42, figs. 348-51. The draft-coupling universally used on freight-cars (*goods wagons*) in England in connection with a *draw-hook*, which see.

Wagon-sheet (English). See *Tarpaulin*.

Wagon-truck. Fig. 5637. A four-wheeled vehicle for moving baggage or freight about a station or warehouse. See also *Baggage wagon-truck*, fig. 5639. *Freight wagon-truck*, fig. 5637. Two-wheeled vehicles of the same kind are known as *baggage-barrows* and *freight-trucks*, both sometimes designated as *barrow-trucks*.

Wagon-wheel (English). See *Wrought-iron wheel. Steel-tired wheel.*

Wainscot-panel. 76, figs. 435-73, 540-67. A board which forms a panel under the windows between the two *wainscot-rails*.

Wainscot-rails (passenger-car interiors). 74, 75, figs. 435-73, 540-67. Longitudinal wooden strips fastened to the posts and extending from one end of the car to the other. The *lower wainscot-rail* comes immediately above the truss-plank; the *upper wainscot-rail* is immediately under the window. The *wainscot end-rails* are the *wainscot-rails* at the end of the car.

Waist-panel (English). 124, fig. 501. The panel immediately above the lowest panel on the outside of a carriage body.

Waist-rail (English). 100, figs. 501-4. A horizontal piece in the framing of the side of a passenger-carriage.

Wakefield car-seat. 1. Figs. 3980-7. A revolving and folding car-seat. Figs. 3980, 3984-6. A car-seat with a seat-back, 2, fixed by the arm or *revolving base-top* fastened to the *seat-ends*, 4, 5, 6, which are carried on a heavy *connecting frame-rail*, 40, and the *seat-support extension*, 41, which *frame-rail* rests upon a *pedestal*, 7, on which it rotates like a revolving-chair, but may be firmly secured by a *spring-lock*, 42.

2. A *swing-back seat* resting upon the ordinary seat-frame, but with a straight *seat-back arm* fastened to the back near the top, and a smaller auxiliary arm, called the *arm-crank*, to adjust the lower part of the *seat-back*. This *arm-crank* is pivoted in a slot in the *seat-back arm* and is also guided by a *wall end-slide*, which carries the end down so that the *seat-back* can swing through between the *seat-back arms*.

Walker Manufacturing Company's electric-motor. (Street-cars.) Fig. 5674.

"**Walk-over**" car-seat. Figs. 3917-18. A swing-back car-seat of recent design, introduced by Hale & Kilburn.

Wall seat-end. The seat-end next the wall or side of a car, so called in distinction from the *aisle seat-end*.

Wall-socket casting. 8, figs. 3917-25. A casting bolted or otherwise fastened to the inside end of seat to which the striker-arms are pivoted and in which the mechanism that tilts the cushion is placed; the *seat-end connecting-rail* is also fastened to this casting.

Wards (of a lock). 5, figs. 2766-7. The interior circular ridges which fit into corresponding recesses in the *bit* of a key (the latter also termed *wards*), the surrounding solid parts of the bit being called the *web*.

Warehouse-truck. Figs. 5635-41. A small vehicle which is used for moving freight about a warehouse. See *Barrow-truck Wagon-truck*.

Wash-basin. Figs. 3508-9. The metallic wash-bowl of a folding lavatory.

Wash-bowl, or wash-basin. 1, figs. 3525-7; B, figs. 3542-7. A *basin*, which see. They are used in sleeping and

drawing-room cars, and generally form a part of a fixed wash-stand.

Wash-bowl pipe. A waste-pipe.

Washburn-wheel. 1. Figs. 5268, 5330-1, 5348, etc. A cast-iron car-wheel, designed and patented by Nathan Washburn in 1850, and now more used, perhaps, than all other forms put together. It consists of two plates, which extend from the hub to about half the distance between it and the rim. There they unite into one plate which extends to the rim. The plates are all curved so as to contract when the wheels are cooled without danger of fracturing the wheel. The single plate and the rim are united together and strengthened by curved ribs cast on the inside of the wheel.

2. Wheels of any type made by the Washburn Car Wheel Company. Figs. 5330-4.

Washer. 1. Fig. 3716. A plate of metal or other material, usually annular, which is placed under a nut or bolt-head to give it a better bearing. Two or more washers are sometimes combined and called *washer-plates*, *strap-washers*, *double* or *twin washers*, *triple washers*, etc., as fig. 3719; they are sometimes made *beveled* or *triangular*, figs. 3717-18, 3721, for a rod or bolt which is oblique with reference to the bearing surface. A *socket-washer* or *flush-washer* is one provided with a recess for the bolt-head so as to leave it flush with the surface of the adjoining parts. *Cut washers* or *wrought washers* are those stamped out of rolled iron plates. *Cast washers* are made from cast-iron. Both are largely used. Washers in car work all take their name from that of the bolt or rod to which they are attached, except the *base-washer*, which stands at the base of the platform-posts on passenger-car platforms. A *gasket*, which see, is sometimes called a washer.

2. A brush for washing objects, as *car-washer*, figs. 3698, 3701-2.

Washer-plate. A *strap-washer*, which see.

Wash-room. Fig. 3468. A *lavatory*. A compartment which constitutes the *vestibule* of ordinary parlor and sleeping cars, provided with toilet facilities. In private and officers' cars it is placed in various irregular positions to leave the ends of the car free. Wash-rooms with pumps and water-tanks underneath the wash-bowls are being replaced on Pullman cars by what is known as the *Pullman compressed-air system of water supply*, figs. 3534-48. See the same and *lavatory*.

Wash-room furnishings. Figs. 3468-3606.

Wash-room pump. Figs. 3481-2. More properly *basin-pump*, which see. They are either *single* or *double-acting*.

Wash-stand (postal-cars). A cast stand carrying a basin. They are distinguished as corner or side wash-stands.

Wash-stand sink. A cast-iron plate with one or more bowls, made in one piece and lined with porcelain and used for the top of a wash-stand. Used only in second-class cars.

Wash-stand slab. 3, fig. 3468; 2, figs. 3525-7. A stone slab which forms the top for a wash-stand. Commonly, simply slab.

Waste. The spoiled bobbins of cotton mills, used for wiping machinery and for *journal-packing*, which see. Although valueless for the manufacture of cloth, the consumption is so large that waste is quite expensive. A cheaper substitute for use as journal-packing is *patent-waste*, which see.

Waste-cock. 1. (Baker heaters.) A cock attached to the *expansion-drum* or *circulating-drum* of the Baker heater for drawing off or changing the water in the heater-pipes.

Waste-pipe stud (Westinghouse pump-governor). 35, fig. 1716.

Water-alcove. Figs. 3552-3. A recess in the side of a partition of a passenger-car to receive the faucet of a water-cooler or water-pipe and a drinking-cup. The

term is generally used to designate the metal casing or lining with which the recess is covered. The water-tank for supplying water-alcoves is usually placed on the other side of the partition, in the saloon, and commonly when so placed extends to the roof.

Water-alcove front. Fig. 3552. See above.

Water-alcove pan. Fig. 3552. See above.

Water-closet. Fig. 3854. "A commode with water supply to rinse the basin and carry off the contents."—*Knight*. The water-closet is in increasing use in passenger-cars. At present it is mainly confined to private cars. It is sometimes provided with an upholstered cover, and is then known as a *concealing* water-closet. See *Howard's parlor-car water-closet*, figs. 3838-40; *The H. C. Hart water-closet*, fig. 3854.

Water-cooler. 14, figs. 3468, 3525-7 and figs. 3549-54. A tank or vessel for carrying drinking water which is usually cooled with ice. The sides are generally made double, and the space between filled with some non-conducting substance. They frequently extend to the roof. See *Water-alcove*. *Water-tank*.

Water-cooler ear. Fig. 3555.

Water-cooler furnishings. Figs. 3549-57.

Water-cooler stand. Figs. 3549-50.

Water-cooler top and breast. Figs. 3556-7.

Water-cooler valve or waste-cock. Fig. 3486. See *Tank waste-cock*.

Water drip. 1. A pan or receptacle to receive the waste water from a water-cooler. A *drip-pipe*, or *waste-pipe*, connects with it.

2. CC, figs. 468-70, and figs. 461, 491, etc. A slight projection or raised seam in the roof of a passenger or baggage car over the side doors, or at the end of the car in the platform roof to divert the water so it shall not fall upon persons entering the car or passing from one car to the next.

Water reservoir (Baker heater). Fig. 2903. See *Circulating drum*.

Water-table. 1. (Masonry.) A projecting beveled face of stone to shed water from the parts below. Hence, especially applied to the top course of a foundation, which nearly always has such a face, the masonry above being set back.

2. A *window-ledge*, which see.

Water-tank. 1. A vessel or reservoir for holding water. Those used on cars for drinking water are usually made of sheet-iron, and often extend to the roof. They are then usually drawn from by a *water-alcove*, figs. 3552-3, the tank being usually in the corner of the saloon concealed from the interior of the car. The tanks for supplying wash-room basins, fig. 3468, are usually placed immediately under them and drawn from by a *basin-pump*.

2. (Howard's parlor-car water-closet.) Figs. 3838-9.

Watson and Stillman's jacks. Figs. 3728-35, 3742. These jacks are the result of thirty years of experience. In their construction the old style solid inflexible ring packing of the socket has been done away with, and in its stead there has been introduced behind the socket a lubricated packing and gland or stuffing box, thus retaining the flat lever which has been one of the characteristics of this style jack. In order that this packing may be renewed without taking the jack entirely apart, the set-screw which retained the socket has been removed from the inside of the head and placed outside and back of the head, where it engages with the end of the socket.

In jacks in which the pump is inside the ram, the lower valve is pushed from its seat by the end of the piston-rod, and the water returns to the upper part of the jack by passing around the piston-valve.

To make the piston-valve and packing accessible, the bottom of the pump is closed by a simple packed plug which contains the ram-valve. This plug is screwed

into the bottom of the ram, allowing the ram to come clear down to the packing, thus preventing the leaking above the pump-collar. The pump-packing can be renewed without taking the jack apart, by slacking the set screw in the head and withdrawing the socket just far enough to revolve past the lug on the head, and so push the packing out of the pump.

The introduction of gland packing on the socket, and cup packing in the pump, materially reduces the labor of pumping, and adds largely to the wearing qualities of the pump packing. See *Hydraulic jack*. *Dudgeon-jacks*.

Watt's tail-lamp. Fig. 3319 shows it in section.

Watt's combination caboose tail-lamp. Figs. 3326-8.

Waved moldings. Moldings which by a special machine are made of a corrugated section longitudinally, the number of waves or corrugations varying from 3 to 6 per inch. The cost of the moldings is increased by this waving from $1\frac{1}{2}$ to $2\frac{1}{2}$ cents per foot.

Way-car. Fig. 54. A *caboose-car*, which see. Sometimes a so-called *way-car* partakes more of the character of a tool-car. The application of the term is not well defined.

Weather strips. Figs. 2819-24, 4534-41. A rubber strip with a metallic or wooden binding to apply around the crevices of windows or doors, for excluding the dust and wind, and for preventing water from entering around the windows. Weather strips are divided generally into *single-edge* strips, fig. 4537, and *cushion* strips, fig. 4534, etc., both being usually provided, as now manufactured, with a wood or metal *molding*. The cushion strip is simply rubber, folded over so as not to show a selvage edge. The standard widths of weather strips are $\frac{3}{8}$, $\frac{1}{2}$, $\frac{3}{4}$, and 1 in. They are usually made in lengths of fifty feet, but some of the cushion strips in lengths of only 7 ft. See *Bosley metallic and excelsior weather-strips*, figs. 4534-39, and *Casper's metallic weather-strips*, figs. 4540-1.

Web (of a key). The solid portion of the *bit* of a key, the recesses cut away being termed *wards*. See *Bit*.

Webbing. A strong fabric, from one to four inches wide, made of hemp or other material which is not liable to stretch, used in upholstering car-seats. A detached spring-section is shown in fig. 3931, showing the application of the webbing. Others are shown in figs. 3929-44.

Wedge. 1. A term in quite general use for a *journal-bearing key*, which see. Figs. 5339-5418. See also *Stop-wedge*, figs. 5145, etc.

2. (Miller platform.) The *uncoupling-lever wedge*, attached to the platform by a *wedge-chain*.

Wedge-chain. See above.

Weed-cutting car. Fig. 5588. A hand-car equipped with a cutting bar, knives and pitman rod like a mowing-machine, for cutting the weeds at the side of a track over which the car is run.

Weigh-bar (English). See *Brake-shaft*.

Westinghouse air-brake. A system of continuous brakes invented and patented (the first patent in 1869) by Mr. George Westinghouse, Jr., which is operated by compressed air. The air is compressed by a steam air-pump on the locomotive, and is stored up in a tank called the *main reservoir* on the engine or tender. By the original form of brake the compressed air was conveyed from the tank by pipes connected together between the cars by flexible *brake-hose* to *brake-cylinders* under each car, by means of which the pressure of the air was communicated to the brake-levers, and thence to the brake-shoes. A later and improved form is the *Westinghouse automatic air-brake*, commonly called simply *Westinghouse brake*, which is now in universal use. At the present time the *Westinghouse brake*, unless otherwise specified, is always understood to mean the *automatic*

the original form of the Westinghouse air-brake (see above) in order to make it automatic was to carry a full pressure of air at all times in the brake-pipes and cause the brakes to be applied by a reduction of this pressure instead of by the admission of pressure, so that the breaking apart of the train or a reduction of pressure by escape of air at any point on the brake-pipe would apply the brakes to the whole train at once. A further advantage was that the action of the brakes was made quicker by saving the appreciable interval of time required for the compressed air to flow from a single reservoir at one end of the train in sufficient quantities to fill all the brake-cylinders. An *auxiliary reservoir* is placed under each car, containing air at the same pressure as in the brake-pipes and main reservoir. An ingenious valve called the *triple-valve* connects the brake-pipe, auxiliary reservoir and brake-cylinder together in such manner that any reduction of pressure in the brake-pipe opens a passage for the air from the auxiliary reservoir to the brake-cylinder, applying the brakes, and closes the connection between brake-pipe and reservoir. To release the brakes, the pressure in the brake-pipes is restored; when the triple-valve closes the connection between the auxiliary reservoir and brake-cylinder and opens one between the brake-cylinder and the outer air and between the auxiliary reservoir and the brake-pipe. In order that the train brakes may be applied from any car, each car is fitted with a valve called the *conductor's valve*, connected to the brake-pipe, so that the compressed air therein can be permitted to escape by opening the valve. Additional parts to perfect the working of the brake-gear in practice (but not required in theory for its complete application) are the *pump-governor*, fig. 1716, *Drain-cup and air-strainers*, figs. 1719 and 1746, etc.

Westinghouse electric-motor (for street-cars.) Fig. 5677.

Westinghouse freight-brake. Figs. 1728-9; 1695-8. A device not differing essentially from the Westinghouse passenger brake-gear except that the parts are made lighter and cheaper for use on freight-cars. To this end the triple-valve, reservoir and brake-cylinder are commonly combined in one part, as in fig. 1728-9. The engine, air-pump and main reservoir, on the contrary, are made somewhat larger. Special arrangements for operating extra long trains and on extra heavy gradients have been introduced, as shown in the engravings. See *Air-brake* and *Straight air-brake*.

Westinghouse train-signaling apparatus. Figs. 2388-2407. A device for utilizing the supply of compressed air required for operating the Westinghouse brakes to transmit signals to the engine instead of using the ordinary bell-cord. See *Train-signaling apparatus*.

Wheel. 1. A circular frame or solid piece of wood or metal which revolves on an axis.

See <i>Brake-wheel.</i>	<i>Ratchet-wheel.</i>
<i>Gear-wheel.</i>	<i>Spur-wheel.</i>
<i>Hand-wheel.</i>	<i>Winding-shaft ratchet-wheel.</i>
<i>Brake ratchet-wheel.</i>	

2. Figs. 5255-5376, and 5620-34. A circular frame or disk, as above defined, serving to support a moving vehicle, as *car-wheel* (which see), *hand-car wheel*, *street-car wheel*, etc. Car-wheels are generally either *cast* (*chilled*) or *steel-tired*. Steel wheels and the *Saxe & Kear wheel* do not come fully under either of these titles. See words in italic for further details. See also *Wheel-tread*. *Car-wheel*. *Chill*.

The defects of wheels for which cars may be refused under the rules for the *interchange of traffic* are as follows:

(a) Shelled out; wheels with defective treads on account of pieces shelling out, leaving flat spots deepest at the edge, with a raised center. (See fig. b.) Wheels

must not be condemned from this cause, unless the spots are over $2\frac{1}{2}$ inches, or are so numerous as to endanger the safety of the wheel.

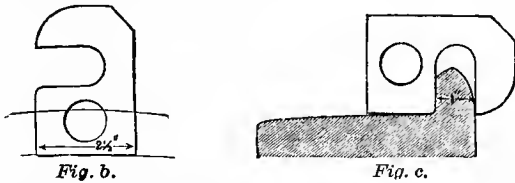

(b) Seams 1 inch long or over at a distance of $\frac{1}{2}$ inch or less from the throat of the flange, or seams 3 or more inches long on any other point of the tread.

(c) Worn through chill; when the flat spot caused by wear exceeds $2\frac{1}{2}$ inches in length. Care must be taken to distinguish this defect from flat spots caused by sliding wheels.

(d) Worn flange; flanges 1 inch thick or less, or having flat, vertical surfaces extending more than 1 inch from tread. (See figs. c and d.)

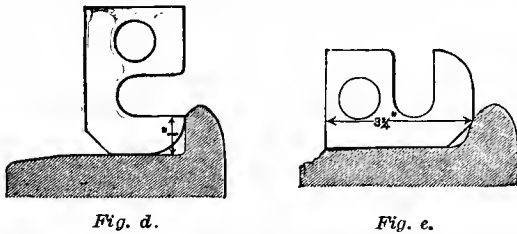

(d¹) Thick flange; flanges over $1\frac{7}{16}$ inches thick. This does not apply to wheels cast prior to September 1, 1894.

(e) Tread worn hollow; if the tread is worn sufficiently hollow to render the flange or rim liable to breakage.

(f) Flat sliding; if the flat spots caused by sliding exceed $2\frac{1}{2}$ inches in length. Care should be taken to distinguish this defect from worn through chill.

(g) Burst; if the wheel is cracked from the wheel fit, outward, by pressure from the axle.

(h) Broken or chipped flange; if the piece broken off exceeds $1\frac{1}{2}$ inches in length and $\frac{1}{2}$ inch in width, or if it extends $\frac{1}{2}$ inch past center of flange.

(i) Broken or chipped rim; if the tread, measured from the flange at a point $\frac{5}{8}$ inch above tread, is less than $3\frac{1}{2}$ inches in width. (See fig. e.)

(j) Cracked tread.

(k) Cracked plate.

(l) One or more cracked brackets.

(m) Broken in pieces.

NOTE.—The determination of flat spots, sharp flanges, thin flanges and chipped treads shall be made by a gage as shown in fig. a. The determination of thick flanges shall be made by a gage, as shown, applied to M. C. B. standard wheel tread and flange, in fig. 5488.

The engraving of the wheel defect gage is shown in fig. a, made on a reduced scale, and the method of using it is shown in figs. b, c, d and e.

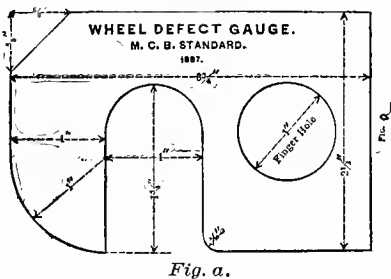

3. Defects of mounting wheels. (Interchange of Traffic.) Fig. 5421. The defects for which cars may be rejected are as follows:

(q) Loose wheel.

(r) Out of gage, or wheels that measure less than 4 feet 5 inches or more than 4 feet $5\frac{1}{2}$ inches between flanges or less than 5 feet 4 inches over treads. (See fig.

5421.) This does not apply to wheels cast after September 1, 1894.

(r¹) Out of gage, or wheels that measure less than 4 feet $5\frac{1}{2}$ inches between flanges or more than 4 feet 6 $\frac{1}{2}$ inches from the back of flange of either wheel to gage line of mate wheel, or less than 4 feet $11\frac{1}{2}$ inches from gage line of either wheel to outer edge of tread of mate wheel. (See gage, fig. 5486.) This does not apply to wheels cast prior to September 1, 1894.

4. Prices of wheels and cost of mounting. See *Interchange of traffic*.

Wheels, Specifications for cast-iron. (Master Car-Builders' Recommended Practice.)

In 1893 specifications for cast-iron wheels and a form of guarantee by manufacturers, were adopted as Recommended Practice; these had formerly been standards of the Association.

They are as follows:

1. "The chills in which the wheels of any one wheel-maker are cast shall be of equal diameters, and the same chill must not vary at different points more than one-sixteenth of an inch in diameter."

2. "Wheels of the same nominal diameter furnished by any one wheelmaker must not vary more than one-fourth of an inch above or below the mean size measured on the circumference, and the same wheel must not vary more than one-sixteenth of an inch in diameter. The body of the wheel must be smooth and free from slag, shrinkage or blow-holes. The tread must be free from deep and irregular wrinkles, slag, chill cracks, and sweat or beads in throat, which are one-eighth of an inch or over in diameter, or which occur in clusters of more than six inches in length."

3. "The wheels broken must show clean gray iron in the plates; the depth of pure white iron must not exceed seven-eighths of an inch or be less than three-eighths of an inch in the middle of the tread, and shall not be less than three-sixteenths of an inch in the throat. The depth of the white iron shall not vary more than one-fourth of an inch around the tread on the rail line in the same wheel."

4. "For each hundred wheels which pass inspection and are ready for shipment, one representative wheel shall be taken at random and subjected to the following test:

"The wheel shall be placed flange downward on an anvil block weighing not less than seventeen hundred (1,700) pounds, set on rubble masonry at least two feet deep, and having three supports not more than five (5) inches wide for the wheel to rest upon. It shall be struck centrally on the hub by a weight of one hundred and forty (140) pounds falling from a height of twelve (12) feet. Should this wheel stand five (5) blows without breaking into two or more pieces, the hundred wheels shall be accepted."

"The above tests shall apply to standard weight wheels from twenty-six to forty-two inches in diameter, used on the standard gage roads."

"Or, the wheel shall be placed flange downward on a cast-iron ring weighing one thousand (1,000) pounds, the outside diameter of the ring being thirty-six and one-half (36 $\frac{1}{2}$) inches, the inside diameter twenty-four (24) inches, and thickness eight (8) inches, supported on rubble masonry at least two feet deep. It shall be struck on the plate, close to the rim, by a weight of one hundred (100) pounds falling from a height of seven (7) feet. When subjected to this test a five hundred and fifty (550) pound wheel shall stand twenty (20) blows; a five hundred and seventy-five (575) pound wheel, twenty-five (25) blows, and a six hundred (600) pound wheel thirty (30) blows without breaking a piece out. This test applies to 33-inch wheels; 26, 28 and 30-inch wheels must stand the twenty-five-blow test, and 36 and 42-inch wheels must stand the thirty-blow test."

5. "Should, in either case, the test wheel break in two or more pieces with less than the required number of blows, then a second wheel shall be taken from the same lot and similarly tested. If the second wheel stands the test, it shall be optional with the inspector whether he shall test a third wheel or not. If he does not so select, or if he does and the third wheel stands the test, the hundred wheels shall be accepted."

6. "Wheels shall not vary from the specified weight more than two per cent."

7. "The flange shall not vary in the same wheel more than three thirty-seconds of an inch from its mean thickness."

8. "All wheels shall be numbered consecutively, and shall have the number, also the day, month, and year when made, plainly formed on the inside plate in casting, and no two wheels shall have the same number."

Wheels, guarantee for cast-iron. (M. C. B. Recommended Practice.)

1. "This indenture, made this.....day of..... 18....and between party of the first part, andparty of the second part, Witnesseth:

"The party of the first part hereby agrees to furnish to the party of the second part, free on board cars at chilled cast-iron wheels.... inches in diameter, for use under

2. "The party of the second part hereby agrees to pay to the party of the first part dollars for each wheel furnished, and to keep an accurate account of the mileage made by the wheels placed in service under cars in passenger equipment and under locomotives and tenders, and an accurate record of the number of months of service of the wheels placed in service under cars in freight equipment."

3. "The party of the second part hereby agrees, when any wheel furnished under the contract is scrapped, to furnish to the party of the first part a statement which will show: 1. The wheel number. 2. The service in which the wheel ran. 3. The amount of service in months or miles. 4. The cause of failure. 5. A charge against the party of the first part of fifty-five per cent. of the price of the wheel mentioned above. 6. A credit to the party of the first part of

.. cents per 1,000 miles for 36 in. passenger equipment.	..	"	"	"	"	33	"	"	"
.. " " " " " " " "	..	"	"	"	"	30	"	"	"
.. " " " " " " " "	..	"	"	"	"	36	"	locomotive and tender equipment.	"
.. " " " " " " " "	..	"	"	"	"	33	"	"	"
.. " " " " " " " "	..	"	"	"	"	30	"	"	"
.. " " " " " " " "	..	"	"	"	"	28	"	"	"
.. " " month " " " " " "	..	"	"	"	"	36	"	freight equipment.	"
.. " " " " " " " "	..	"	"	"	"	33	"	"	"
.. " " " " " " " "	..	"	"	"	"	30	"	"	"

"Except in case of wheels removed for the following causes: 1. Flat by sliding. 2. Chipped flange. 3. Broken flange, if the breakage is not caused by seams, worn through chill or worn flange. 4. Broken or chipped rim, not caused by rim being hollow. 5. Breakage of any kind caused by wreck or derailment."

4. "The party of the first part hereby agrees, on presentation of the statement above mentioned, to pay the party of the second part any balance due from lack of sufficient service on the part of the wheels (with above exceptions), to balance the charge, and the party of the second part hereby agrees to pay the party of the first part any balance due as shown by the aforesaid statement, settlements to be made quarterly."

5. "The party of the second part hereby agrees to hold, subject to the inspection of the party of the first part for a period of thirty days after said statement has been presented (with above exceptions) which shall be a credit equal to the

6. "It is understood that the basis of settlement shall be as follows:

36-inch passenger wheels	70,000 miles.
33-inch passenger wheels	60,000 miles.
36-inch engine and tender wheels.....	60,000 miles.
33-inch engine and tender wheels	50,000 miles.
30-inch engine and tender wheels	45,000 miles.
28 and 26 inch engine and tender wheels..	40,000 miles.
Refrigerator, through line and cattie cars.	24 months.
All other freight cars.....	48 months."

Wheels (distance-gages between flanges). The standard distance between the backs of car wheels, as indicated, fig. 5421, is 4 feet 5 7/8 inches; drawing shows the form of gage for measuring this distance. In 1885 it was decided by letter ballot that in fitting wheels on axles a variation of 1/8 inch each way from the standard distance of 4 feet 5 7/8 inches between the flanges would be allowed, making the maximum distance 4 feet 5 1/2 inches, and the minimum distance 4 feet 5 3/4 inches. See *Check gage*.

Wheel and track (terms and gaging points). Fig. 5485. Standard terms and gaging points for wheels and track were adopted in 1894, as follows:

1. Track rails are the two main rails forming the track.
2. Gage of track is the shortest distance between the heads of track rails.

3. Base line, for wheel gage, is a line parallel to the axis of the wheels drawn through the point of intersection of tread with a line perpendicular to the axis, and passing through the center of the throat curve.

4. Inside gage of flanges is the distance between backs of flanges of a pair of mounted wheels measured on a line parallel to the base line, but 1/8 inch nearer to the axis of the wheels.

5. Gage of wheels is the distance between the outside faces of flanges of a pair of mounted wheels measured on a line parallel to the base line, but 1 1/4 inches farther from the axis of the wheels.

6. Thickness of flange is the distance measured parallel to the base line between two lines perpendicular thereto, one drawn through the point of measurement of "gage of wheels."

7. Width of tread is the distance measured parallel to the base line from a line perpendicular thereto, drawn through the point of measurement of "gage of wheels" to the outer edge of tread.

8. Check gage distance is the distance measured parallel to the base line between two lines perpendicular thereto, one drawn through the point of measurement of "inside gage of flanges" on either wheel, and the other drawn through point of measurement of "gage of wheels" on mate wheel.

9. Over all gage is the distance parallel to base line from outer edge of one wheel to the outer edge of mate wheel.

The above mentioned wheel gage distances are either directly or by inference as follows:

Inside Gage of Flanges.....	4 feet 5 7/8 inches.
Gage of Wheels	4 " 8 1/2 " "
Thickness of Flange.....	1 1/2 " "
Width of Tread.....	4 1/2 " "
Check Gage Distance.....	4 " 6 3/4 " "
Over All Gage.....	5 " 4 3/8 " "

Wheel-bar (iron six-wheel truck). A substitute of an iron for a wooden *wheel-piece* to which the pedestals are attached.

Wheel-boss (English). 26, figs. 348-51. American term, *hub*. The center of the wheel, which is bored out to receive the axle.

Wheel-box (street-cars). 21, figs. 5634-6, etc. A covering for a wheel which projects through the floor. The sides are usually of wood and the top of sheet-iron, but they are sometimes made entirely of wood or metal.

Wheel-box button. A stick of wood attached by a bolt to the top of a wheel-box so that it can be turned, somewhat like a door-button, to hold the wheel-box in its place.

Wheel-center (steel-tired wheels). Figs. 5255, etc. The portion of a wheel inside of the tire, and between it and the hub or boss. The wheel-center is sometimes in one piece and sometimes made up of two parts, the *hub* or *boss* and the *central filling-piece*, which see. *Face-plates*—front and back, are also used. The term is seldom applied to chilled or cast wheels.

Wheel center, or skeleton. 26, 27 and 28, figs. 348-51. The whole of a railroad wheel, except the tire, and the fastenings which connect the tire to the *rim*.

Wheel check-gage. See *Check-gage*.

Wheel circumference measure. Figs. 5423-4. By letter ballot in 1893, the wheel circumference measure, shown in fig. 5422, was adopted as a standard of the Association. Prior to that date it had been recommended for use in all car building shops.

Wheel-cover (English). 188, figs. 501-4. See *Splasher*.

Wheel-cut glass. The ordinary process of glass cutting, which leaves a perfectly polished and perfectly transparent surface.

Wheeler car-seat. A car-seat which has a *Swing-back* that is removable. The *Seat back-arm* is forged with a T-end, this T-end is carried by two parallel-rods, the lower ends of which are separately pivoted to the seat-frame so as to keep the *seat back-arm* nearly vertical, in all positions of the seat-back.

Wheel-fit. See *Wheel-seat*.

Wheel-flange. Fig. 5487-9. The projecting edge or rim on the periphery of a car-wheel for keeping it on the rail.

Wheel-flange-thickness gages, for new wheels. Fig. 5488. Maximum and minimum wheel-flange thickness-gages for new wheels were adopted as standard in 1894. They are shown along with the standard form of wheel tread and flange for easy reference. These gages admit a variation of 1-16 inch either way from the standard thickness of 1 1/8 inches when measured, as shown. Such gages should be used on all new wheels after September 1, 1894, to insure ability to mount them properly to check gage.

Wheel-flanges, gages for max. and min. thickness (M. C. B. Standard). Fig. 5488. See *Wheel*.

Wheel-piece. 10, figs. 4842-4966. A stick of timber in a wooden-frame truck, which forms the side of the frame and to which the pedestals are attached. It is often stiffened by outside and inside *wheel-piece plates* or by a *wheel-piece truss-rod*, the latter serving also as a *wheel-piece tie-rod* to tie the two end-pieces firmly to the wheel-pieces. A wheel-piece tie-rod is in all cases used, but it is not always used in the form of a truss-rod. Iron wheel-pieces are sometimes called *wheel-bars*.

Wheel-piece plate. 11, 12, figs. 4842-4966. See above.

Wheel-piece tie-rod. See above.

Wheel-piece truss-rod. 13, figs. 4842-4966. See above.

Wheel-plate. 1. (Cast-iron wheels.) 22, fig. 5355-61.

That part of a plate car wheel which connects the rim and the hub. It occupies the place and fulfills the same purpose as the spokes do in an open or spoke wheel. See *Car-wheel*. *Wheel*. *Washburn wheel*. *Plate wheel*.

2. (Steel-tired wheels.) Figs. 5255-5347. See *Face-plate*.

3. (English.) 188, figs. 501-4. See *Splasher*.

Wheel-ribs (cast-iron wheels). Figs. 5335-8. More commonly, *brackets*. Projections cast usually on the inner side of plate car-wheels to strengthen them. They are placed in a radial position and are often curved so as to permit the wheel to contract when it cools.

Wheel-seat or wheel-fit (of an axle). The part which is inserted in the hub of a wheel. It is made truly cylindrical and very slightly larger than the *axle-seat* of the wheel. The wheel is pressed on it by hydraulic pressure and very rarely becomes loose. When this occurs, or the axle was turned too small, *prick-punching* and even *shimming* the seat has been resorted to to make a

tighter fit, but this practice has never been common. It is a hasty and dishonest expedient and forbidden by the Rules of *Interchange*. See *Wheels*.

Wheel-timber. A *wheel-piece*, which see.

Wheel-tires, minimum thickness of steel tires (M. C. B. Recommended Practice). Fig. 5489. See *Interchange of Traffic*. *Steel-tire*.

Wheel-tread. Fig. 5424. The outer surface or part of a car-wheel which bears on the rails. The standard width of wheel-tread is 5 1/2 in. measured from outside of tread to inside of flange, *i. e.*, including the entire thickness of the flange. See fig. 5487.

Wheel-tread and flange. Fig. 5487. This form of wheel tread and flange was adopted as a standard of the Association by letter ballot in 1886. See *Flange thickness*.

Whisk broom or wisp broom, and holder. Figs. 3696, 3700. A small broom for brushing wearing apparel, furniture and upholstery.

White-metal band. Figs. 4023-8. More properly *seat-back molling*, which see.

White's "anti-friction" car-door hanger. Fig. 2830. See *Car-door hanger*.

Whitney contracting-chill. Figs. 5374-6. See *Chill*.

Whitworth gages. See *Cylindrical gage*.

Whitworth system of screw-threads. A system of screw-threads designed by Sir Joseph Whitworth, of England, and which is almost universally used in that country and throughout Europe. It differs from the Sellers system in that the sides of the threads stand at an angle of 55 degrees instead of 60 degrees, and the tops of the threads and the spaces between them at the root are rounded, as shown in fig. 5496, instead of being flat, as in the Sellers system. The number of threads per inch in the two systems is as follows :

Diameter of screw...	No. of threads per in.....	Diameter of screw...	No. of threads per in.....	Diameter of screw...	No. of threads per in.....	Diameter of screw...	No. of threads per in.....
1/4"	20	1 1/2"	12	1"	8	1 3/8"	5
5/16"	18	1 1/4"	11	3/4"	7	1 1/2"	5 1/2
3/8"	16	1 1/8"	10	1/2"	6	1 1/4"	4 1/2
1/2"	14	1"	9	3/8"	6	1 1/8"	4 1/4

The Whitworth pipe-thread differs from the above. See *Pipe-thread*.

The Whitworth system in this country has practically passed out of use.

Wickes refrigerator car. Figs. 278-82. Shows the Wickes system of refrigeration, slightly modified. In the Wickes car the refrigerator doors open out and are flush with the outside sheathing. See figs. 1850-2. The usual sliding doors are omitted. There is a cooling compartment at each end, occupying the full width of the car and 2 feet 10 inches of the length and separated from the storage compartment by a wooden partition or jacket, which starts about 2 feet from the floor and extends to within about 16 inches of the ceiling.

There are two ice tanks in each cooling compartment. These tanks are constructed of an oak frame work to which are nailed in vertical and horizontal rows, galvanized iron strips 2 inches wide interwoven in the manner of basket-work. Projecting outward from these strips 2 inches are galvanized iron leaves which largely increase the cooling surface. These tanks are separated from one another, from the jacket and from the walls at the sides at the end of the car by air spaces of about 4 inches. They are supported by 2" x 4" oak grate bars 2 feet from the floor. Beneath the bars are many rows of galvanized iron wire, crossing and recross-

ing from side to side of the car. A sloping bottom or apron of galvanized iron at the bottom of the jacket leads the drip water to the wires. There is another apron of galvanized iron in front of the wires extending to within 12 inches of the floor. On the floor, directly under the wires, is the drip-pan with a properly trapped drain at each end. The drip water falls from the ice through the grate bars on to the wires and down into the drip-pan. The warm air enters the cooling compartment through the opening at the top of the jacket and descending as it cools comes in contact with the ice, the metal surface of the tanks, the wires, and the spray of drip water about the wires, and re-enters the car through the opening below the apron in front of the wires, having become cooled, dried and purified. Each tank is iced through an opening in the roof, provided with an inner and outer door, each properly insulated.

This car may be also used for shipment of goods under ventilation. When so used the ice hatches are left open and protected by iron screens. This gives a thorough circulation of air into the openings at the front end, passing the length of the car and out through the openings at the rear end.

Wicket. See *Fare-wicket* (street-cars).

Wick-sleeve (of student-lamp, which see). **I**, fig. 3400.

Wide gage. In general usage, the distance between the heads of the rails of a railroad when it is *slightly* greater than 4 ft. 8½ in. in distinction from *broad gage*, which see, which means a material increase, as to 5 ft. or 6 ft. Wide gage is often used on curves, but its expediency is disputed.

Wind-guard (Pintsch system). **200**, fig. 3227. A perforated brass disc, fitting in globe-holder, **80B**, fig. 3217, below the opal globe. **102**, fig. 3216, and supplied with a small covered hole for admitting a match or taper when lighting the gas. Its purpose is, as indicated by its name, to protect the flame from the action of drafts from below the globe.

Winding-arbor. See *Square-end*.

Winding-gear (pile-driver-car). **41**, **42**, figs. 401-4. Consists of *spools* and a spur-gear of the ordinary form controlled by a *strap-brake* and treadle, so that on the release of the brake the shears attached to the hammer-rope will descend by their own weight and engage with the *hammer-eye*.

Winding-shaft (drop-doors of coal-cars, etc.). **70**, figs. 305-15. A round iron bar supported by the *winding-shaft plates*, to which the *drop door-chain* or *hopper-chain* is attached. It carries a *ratchet-wheel*.

Winding-shaft lever (side-dump ore-car). **131a**. A lever connected to the *winding-shaft* by *ratchet-wheel*, *pawl* and *dog* by which a great torsional or winding stress may be applied to close the side-doors of the car. It is supplemental to a four-arm winch which is connected directly to the shaft and which is used to turn the shaft so far as is possible by such means.

Winding-shaft plate (of a hopper-bottom coal-car). Figs. 305-15. The plate attached to the side of the car carrying the *ratchet-wheel*, *pawl*, and *dog*, serving as a bearing for the winding-shaft. See above.

Winding-shaft ratchet-wheel and pawl. **66**, **67**, figs. 305-15. See above.

Winding-shaft winch. **134**, figs. 332-5. See *Winding-shaft lever*.

Windlass. 1. "(Nautical.) A large horizontal roller journaled in standards (*cheeks*, *winlass-bits*), and rotated by *hand-spikes* or other means. It differs from the *capstan* principally in the horizontality of its axis. Smaller hoisting-machines, turned by cranks, are *winches* and some are specially adapted to machines which re-

ks, etc."—*Knight*.

which, however, is little authorized by the meaning of the word.

Window. **137**, figs. 435-73; 540-1, and figs. 5451-3a. "An opening in the wall of a building or car for the admission of light and of air when necessary. This opening has a frame on the sides, in which are set movable *sashes* containing panes of glass."—*Webster*. Hence the window itself, especially in compound words, is often termed simply the *sash*. In England, carriage windows are technically termed *lights*. See also *Deck-sash*. Car windows are now generally made of uniform size throughout, *twin windows*, *small windows*, etc., are rarely used. In sleeping and parlor cars *double windows* are almost always used to inclose an air-space between them and prevent radiation of heat and drafts. Bay windows are quite common in parlor and private cars.

Window-balance (or sash-balance, which see). **W**, figs. 539-41, and figs. 4542-3. A device in which a spring is used instead of a weight to counterbalance the weight of the sash and glass.

Window-blind. **140**, fig. 435, etc. A wooden screen composed of a frame called the *sash*, carrying *slats*, placed in a window to exclude sunshine. Window-blinds, especially in street-cars, are sometimes made *single*, but for lack of room to raise so large a sash, they are usually made *double* and distinguished as *upper* and *lower*. Window shades have nearly displaced blinds in first-class passenger-cars, blinds being used in the *saloons* only.

Window-blind bolt. Fig. 4406-9, 4411-19. A bolt used for holding a window-blind in any desired position. It enters into *window-blind-bolt bushing* or *plate*.

Window-blind-bolt bushing. Figs. 4407-8. See above. Same as *sash-lock bushing*.

Window-blind lift. Figs. 4422-49. Commonly called simply *blind-lift*. A metal hook fastened to the blind for raising and lowering it, usually attached to the bottom-rail, but in street-car blinds, which are lowered below the window, to the top rail. Window-blind lifts are distinguished as *single* and *double*, the single lift being the upper, and the double lift the lower, which has a projection for raising the outer part. Double window-blind lifts are also distinguished as *lower* and *upper*. The upper lift differs from the lower by *not* having a lug or ledge, which is carried on the lower blind for the purpose of engaging with the upper when the lower one is half raised, so that the two may thereafter be raised together.

Window-blind mullion. **125**, figs. 5654. An upright bar in the center of a window-blind sash.

Window-blind pull. A *window-blind lift*, which see.

Window-blind rail. **122**, **123**, fig. 5654. A horizontal bar of a window-blind sash.

Window-blind rest. 1. A wooden strip to fill up the lower part of the groove in which an upper window-blind slides, and on which it rests when down.

2. (Street-cars.) **23**, fig. 5656. A horizontal strip of wood which extends from one body-post to another, on which the blind rests when it is lowered.

Window-blind sash. **121**, fig. 5654. The frame in which the inclined thin *slats* are held.

Window-blind slat. **126**, fig. 5654. See above.

Window-blind spring. Figs. 4403-5. The same as a *Sash spring*, which see.

Window-blind stile. **124**, fig. 5654. An upright bar in a window-blind sash.

Window-blind stop. An *Inside window-stop*, which see.

Window-casing. A frame which incloses or surrounds a window. Often called an *Inside window stop*.

Window-cornice. A purely ornamental projecting structure, usually made of wood, placed over a window on the inside. It is now little used.

Window cove-molding. **87**, fig. 541. A small concave molding around the sides and top of a window on the inside of a passenger car.

- Window-curtain.** C, figs. 2452-3. A cloth or some kind of textile material loosely hung over a window to exclude sunshine, and which can be spread or drawn aside at pleasure. Curtains of this kind are now little used. *Window-shades*, which see, lie always flat, and are rolled up upon *shade-rollers*. They are often also called curtains.
- Window-curtain bracket.** Figs. 4567-8, 4573-5. More commonly, simply *curtain-bracket*, for supporting window-shade rollers. A more correct term would be *shade or window-shade brackets*, but in common usage, *curtain brackets* support *shade rollers*.
- Window-curtain holder or hook.** Y, figs. 2452-3; figs. 3593-7. A metal hook fastened at the side of a window for holding a curtain when drawn aside. *Knobs* are also used.
- Window-curtain knob.** A form of *window-curtain hook*.
- Window-curtain leather.** Figs. 4552-9. More properly, *window-shade leather*.
- Window-curtain pulley.** Figs. 4569-70. Practically obsolete. See *Shade and curtain*.
- Window-curtain rings.** Figs. 3579-82. See *Curtain*.
- Window-curtain rod.** Figs. 3564-6. See *Curtain*.
- Window-curtain roller.** Figs. 4564-6. More properly, a *shade*, or *window-shade roller*, which see.
- Window deflector-ventilator.** See *Deflector and ventilator*.
- Window dust-guard or deflector.** Figs. 4527-30. A thin narrow-board of the height of the window adjusted perpendicular to the car side at the forward edge of the window, to deflect dust and cinders so they shall not enter the open window. It is fastened to the window casing by a *Dust-guard spring-holder*, fig. 4533.
- Window-fastener.** Figs. 4465-90. A *sash-lock*, which see.
- Window-furnishings** (for deck-sashes). Figs. 4330-4402. (For lower windows.) Figs. 4403-4575.
- Window-glass.** Panes of glass used for windows. They are either *plate* or *rolled* glass, made by pouring the molten glass on to a table having the height of the desired thickness of the plate, and then passing a roller over the top, or *blown*, or common *window-glass*, the latter being by far the cheapest and most widely used, but of very much inferior quality. It is made by blowing the glass into a large bulb, which is then slit open while still hot and flattened out.
- Window-grating.** A wrought or cast iron partition made of bars, or in other form, placed on the outside of the windows of passenger-cars to prevent passengers from putting their heads or arms outside. Now rarely used.
- Window-guards** (street-cars). 117, fig. 5656, figs. 3773-4, etc. Small metal rods to act as fenders for the end windows.
- Window-holder.** A *window-button* or *sash-holder*, which see.
- Window-latch.** Figs. 4473-90. A *sash-lock*, which see.
- Window-latch stop** (lower and upper). See *Sash-lock stop*.
- Window-latch plate.** A form of *sash-lock stop*.
- Window-ledge** (street-cars). 50, figs. 5654-67. A projecting molding outside of a car which extends from one end of it to the other above the windows, intended to shed the rain. A *water-table* or *window-lintel*.
- Window-lift.** See *Sash-lift*.
- Window-lintel.** 90, figs. 435-73. A horizontal strip on the outside of a passenger-car between the posts and over the window-openings.
- Window-molding** (passenger-car interiors). 88, figs. 435-73. Known to the trade as *car moldings*, and used around or on each side of a window, especially to cover the joint between the panel and post. It sometimes forms a groove on the post in which a window or window-blind slides, in place of the *inside window-stop*, which see.
- Window-molding base.** An ornament made of wood or metal attached to the lower end of a window-molding.
- Window-molding joint-cover.** A piece of metal or wood used to cover the joints of window-moldings when two pieces join each other.
- Window-panel.** 68, figs. 435-73. See *Panel*. A panel between the windows known as *inside*, *outside* and *end*.
- Window-panel furring.** 59, figs. 435-73. Horizontal distance-pieces between the window-posts to which the panel is fastened.
- Window-pilaster, cap and base.** 8, 9, 10, fig. 2451. A decorative feature of a car interior, placed between the windows and covering the *window-post*.
- Window-post** (passenger-cars). 58, figs. 435-73. A post extending from sill to plate at the side of a window-opening against which the sash and blind slide.
- Window-rail.** A horizontal bar in a window-sash.
- Window-rod bushing.** Figs. 3618-23. A support for the ends of a *curtain-rod*, which see.
- Window-sash.** 85, figs. 435-73. See *Sash*.
- Window-sash balance.** See *Window-balance* and *Sash-balance*.
- Window-sash holder.** See *Sash-lock*. Figs. 4385-4402, 4465-4490.
- Window-sash lift.** A *sash-lift*, which see. Figs. 4491-4526.
- Window-sash rest** (street-cars). A strip of wood extending from one body-post to another, on which the sash rests when lowered.
- Window-sash spring.** Figs. 4403-5. See *Sash-spring*.
- Window-shade.** A window-curtain, which is wound on a roller above the window, in distinction from one which is drawn aside. In car-building it is finished at the bottom with a *window-shade leather*, figs. 4552-9, and heavy *window-shade rod-bar* or *shade-holder*, figs. 4544-5, 4548-9, 4550. A rectangular slot, which is somewhat inaccurately called an *eyelet*, is inserted in the leather to fasten the shade down by slipping it over the sash-lift. In passenger-cars window-blinds have been superseded by shades, and all sleeping and parlor cars have window-shades in place of blinds. An automatic *shade-roller* is always used, the old-fashioned pulleys and cord-tighteners, figs. 4569-70, being practically obsolete.
- Window-shade leather.** 1, fig. 4560, and figs. 4552-9. See above.
- Window-shade stop.** 19, fig. 2451. That part of a shade-holder which engages with or bears against the window-casing and holds the shade.
- Window-shade thumb-latch.** 16, fig. 2451; figs. 4544-59. A thumb-latch which releases the bottom of the shade so it may be moved up or down. It fixes the shade in any position automatically.
- Window-sill.** 77-78, figs. 435-73, 539-67. A horizontal piece of wood or metal under a window, on which the sashes rest when down. There are usually two, *inside* and *outside*. A thin strip called the *window-sill cap* goes above it.
- Window-sill cap.** See above.
- Window-sill molding.** 80, figs. 539-41. A small wooden molding under an inside window-sill. In modern cars it is usually a *belt-molding*.
- Window-spring.** Figs. 4403-5. See *Sash-spring*. *Spring-sash-holder*.
- Window-stile.** 11, fig. 2451. N, fig. 2454. The upright bars of a window-sash.
- Window-stop.** The strips, or *beads*, attached to the window-posts which hold the sashes in place. There are always two, *inside* and *outside*, and *parting-beads* or *sash-parting strips* in between.
- Window-stop** (inside). See *Window-casing*.
- Window-valance.** (Wrongly printed "balances" in engravings.) See *Valance*.
- Window ventilator.** See *Deflector. Ventilator*.
- Wind scoop.** F, figs. 4327-9a. A hood or ventilating-jack (often so called), attached to a pipe passing through the roof of a car, and so formed as to create either an exhaust

draft or the contrary by the current of external air passing over the car. With the Spear heater, figs. 3058-60, a wind scoop is shown.

Wings (pile-driver car). 20, figs. 401-4. See *Pile-driver car* and *swinging-platform*.

Winslow car-roof. Figs. 2355-67. A car-roof, patented by A. P. Winslow, which consists of metal *roof-sheets* laid cross-wise to the car. They are made with corrugations and are let into grooves in the rafters. The latter are covered with strips of sheet-iron and the whole with a layer of transverse boards, which are fastened to longitudinal purlins attached to the rafters or carlines. See *Car-roof*.

Wire. See *Seal-wires*, figs. 3886-7a, 3900. *Woven-wire*, figs. 3952-67.

Wire-base (for lantern). Figs. 3352-4, 3356.

Wire-covered bell-cord. See *Bell-cord*. Little used.

Wire-gauze (for ventilator). A fine netting made of wire with which the outside of deck-windows and ventilator openings are covered to prevent the admission of dust.

Wire shade-tripod. Fig. 3435. See *Shade-ring*.

Wood-center car-wheel. Figs. 5330, 5347. A form of car-wheel used in England almost universally for passenger service, but rarely in this country. The wheel-center is entirely made up of teakwood used as a continuous and solid series of spokes held in place by side-plates and Mansell retaining rings. Called in England the *Mansell wheel*. See *Steel-tired wheel*. *Car-wheel*. *Tire-fastening*.

Wooden brake-block (English). 63, figs. 348-51. A piece of soft wood used in England as a brake-block, which see. Wood is being superseded by cast-iron.

Wooden-wheel (for hand-cars). Figs. 5629-31. A form of *wood center-wheel*, which see. See *Sheffield car-wheel*.

Wooden-frame truck. A car-truck, of which the wheel-pieces and end-pieces are made of wood. Figs. 4813-4966 are illustrations. See *Truck*. *Car-truck*.

Wooden floor-mat (street-cars). A sort of grating made of strips of wood, with distance-pieces and spaces between.

Wood's platform gate. Figs. 3794-6. A gate, the details of which are shown in the figures, that has found considerable favor on steam and suburban roads. When opened it folds against the end of the car quite out of the way.

Wood-screw. A small cylindrical bar of iron or steel with a wood screw-thread cut on it and a slotted head so that it can be turned with a *screw-driver*. A *lug-screw* is a heavy kind of wood-screw, but is not so-called. It has a square instead of slotted head, as fig. 3711. See *Screw*.

Wood screw-thread. A form of screw-thread used for screws which are intended to screw into wooden objects. It differs from a *metal* thread in having the spaces between the projections wider.

World ventilator. Fig. 4315. See *Ventilators*.

Worm. A helix like a screw-thread, for winding a rope or a chain upon. See *Brake-chain worm*. 17, fig. 2441.

Worn flat (car-wheels). Under the rules for the interchange of traffic this defect is defined to be irregular wear under fair usage, due to unequal hardness of the tread of the wheel, and to be carefully distinguished from *slid flat*, which is a defect produced by the slipping of the wheels from excessive brake-pressure. The rules provide that flats exceeding $2\frac{1}{2}$ in. in length are cause for rejection. See *Wheels*.

Woven-wire fabrics (for car-seats and sleeping-car berths). Figs. 3952-67.

Wrecking-car. Figs. 206-7, 212, 392-6. Also called *tool-car* or *derrick-car*. Fig. 207 represents the most powerful, and is used for pulling up steam, and having

See *Derrick*.

one end elevated

to form an incline plane by which derailed trucks can be replaced upon the track, by pulling the car in the direction of its length.

Wrench. A contrivance for screwing and unscrewing a nut. A *monkey-wrench* is adjustable to take nuts of various sizes. A *socket-wrench*, figs. 3214-5, is one having a cubical cavity to receive a *square-end*. The wrenches for the Westinghouse brake are *packing-nut* and *cap-screw wrenches*, and the *discharge-valve seat wrench*. A *spanner*, fig. 1725, which see, is a wrench for use on round or many-sided nuts, like hose-couplings to which lugs or slots are added for engaging with the wrench.

Wrought-iron wheel. 1. Figs. 5263-7, 5274-81, etc. A steel-tired wheel, with a wrought-iron center, either with spokes or with solid plates.

2. (English.) A "wagon-wheel." A wheel in which the rim and spokes are of wrought iron and the hub (boss) is either of wrought or cast iron. If the former the spokes are welded to it, if the latter it is cast round the spokes. The tire is shrunk on. This wheel is largely used in freight (goods) service in England, and in both freight and passenger service on the continent of Europe. See also *Kirtley double-spoke wheel*. *Wheel*. *Car-wheel*.

Wrought molding, or *fascia molding* (English). 122, figs. 501-4. A molding which is worked out of the solid on a horizontal or vertical part of the framing of a carriage body. See *Planted molding*.

X

"X" car-roof. A form of roof little used, except on cheap cars, in which the carlines are, in form at least, independent rafters crossing each other under the upper deck in the form of an X. An "A" car-roof, which see, is a different type of the same general idea; both very unusual.

Y

Yale lock. A form of lock so named from its inventor, which uses a flat key with an irregularly curved edge sliding into a *cylinder* which carries a number of pins, each cut into two parts, as tumblers. The edge of the key raises these tumblers to precisely the right height to bring the joint in them to the edge of the cylinder and permit revolution. The advantages of the lock are its conciseness and simplicity and the difficulty of taking an impression for making a false key. To still further increase this difficulty, a *corrugated key* has been introduced.

Yoke. Figs. 2005-6. 1. A pocket-strap, U-shaped, which contains the spring and follower-plates of a drawbar, as shown in figures 1976, 2010, 2099. It is the means of attaching the drawbar to the spring and follower-plates.

2. A malleable iron guide for the cylinder brake-lever, fastened to the rear end of the cylinder by the *yoke-stud* and *nuts*.

3. (Car-door lock.) F, fig. 2630. A part inclosing the double-armed dog of the spindle in such a manner that the motion of the door-knob in either direction moves back the latch.

4. (Car-trucks.) A *spring-saddle*, which see.

5. (Raoul journal-box, which see.) Figs. 5165-6. A strap embracing the journal-box lid to take up the end thrust. The use of the yoke has recently been abandoned in favor of a sliding cap or lid moving vertically in grooves to open the box for oiling, but falling of its own gravity when oscillation or jarring begins, if by accident lifted.

Yoke lever (Janney coupler). 135, fig. 2301, and fig. 2346. The part connecting the *coupler* and the *buffers* of the draw-gear, by means of which the co-operation of coupler and buffers is secured.

Yoke lever (Janney draft-gear). 135, fig. 2301. See *Janney-Buloup-platform-equipment*.

INDEX TO ENGRAVINGS.

Note.—The following engravings, 5,683 in all, are alphabetically arranged under the following general heads; these nine general headings include the engravings, and they are again sub-classed alphabetically. The page number is put at the bottom of each page.

	PAGE.	FIG. No.		PAGE.	FIG. No.
CARS, General Views, Exterior and Interior.(43 pages, 228 cuts)	2	1	TRUCK DETAILS. ... (115 pages, 244 cuts)	350	5,133
CAR-BODIES. (98 " 390 ")	46	229	M. C. B. STANDARDS AND RECOMMENDED PRACTICE (12 pages, 204 cuts)	365	5,377
CAR-BODY DETAILS(79 " 1,837 ")	142	617	HAND-CARS. (6 " 61 ")	377	5,581
CAR-FURNISHINGS .. (108 " 2,121 ")	221	2,454	STREET-CARS.(9 " 41 ")	383	5,642
TRUCKS(21 " 557 ")	329	4,576			
Total Number of Pages and Cuts			391 pages, 5,683 cuts.		

If the above general arrangement be borne in mind, there will be no difficulty in turning at once to any class of engravings desired, all being alphabetically arranged under their title and sub-title, as shown above and more fully in the following detailed index. Under each of the headings and sub-headings of the following list, the engravings are in general arranged alphabetically, according to the names of roads or otherwise, so far as their nature would permit. In a few cases cars have been grouped together on account of their construction features and uses, in preference to the particular kind of freight carried, and by which name they are usually distinguished. This, it is thought, will not lead to confusion, as they are never widely separated, but are nearly in alphabetical order.

	PAGE.	FIG.		PAGE.	FIG.
CARS, Freight, General Views.			CAR-BODIES, Continued.		
“ “ <i>Box,</i> “ “	2	1	“ Passenger, Coaches	94	419
“ “ <i>Furniture,</i> “ “	2	4	“ “ <i>Combination-cars.</i>	102	447
“ “ <i>Fruit,</i> “ “	3	5	“ “ <i>Combination-cars.</i>	108	468
“ “ <i>Refrigerator,</i> “ “	4	9	“ “ <i>Dining-cars.</i>	110	474
“ “ <i>Flat,</i> “ “	5	16	“ “ <i>Business or Pay-cars</i>	112	487
“ “ <i>Coal or Gondola,</i> “ “	6	21	“ “ <i>Special Suburban-car</i>	115	497
“ “ <i>Dump (Side and End)</i> “ “	8	27	“ “ <i>English Carriage.</i>	116	501
“ “ <i>Logging,</i> “ “	9	34	“ “ <i>Sleeping-cars.</i>	118	505
“ “ <i>Stock,</i> “ “	9	37	“ “ <i>Sides and Roofs.</i>	124	531
“ “ <i>Tank,</i> “ “	12	48	“ <i>Baggage-cars.</i>	132	570
“ “ <i>Caboose,</i> “ “	12	50	“ <i>Baggage and Express.</i>	136	584
“ “ <i>Diagram Views.</i>	14	55	“ <i>Baggage and Mail.</i>	138	599
“ “ <i>Caboose,</i> “ “	17	81	“ <i>Postal-cars</i>	140	605
“ Passenger, General Views.			CAR-BODY DETAILS, General Passenger-car.	124-131	531-569
“ “ <i>Coach,</i> “ “	18	89	<i>For a Box-car.</i>	142	617
“ “ <i>Dining,</i> “ “	21	101	“ <i>Flat-car.</i>	145	916
“ “ <i>Parlor,</i> “ “	23	111	“ <i>Gondola-car</i>	146	1,025
“ “ <i>Private,</i> “ “	24	118	“ <i>Caboose-car</i>	147	1,132
“ “ <i>Sleeping,</i> “ “	25	123	“ <i>Baggage-car.</i>	148	1,176
“ Combination, “ “	27	132	Bolsters, Freight-car	152	1,428
“ Baggage, “ “	29	139	“ <i>Passenger-car</i>	154	1,451
“ Postal, “ “	30	142	Brake-gear	155	1,458
“ Excursion, “ “	32	151	“ <i>Beams.</i>	160	1,546
“ Passenger, Diagram Views.	33	155	“ <i>Heads and Shoes.</i>	162	1,602
“ Working, General Views.	40	206	“ <i>Air, Eames.</i>	164	1,661
CAR-BODIES, Freight, Box-cars, General.	46	229	“ “ <i>Westinghouse.</i>	166	1,688
“ “ “ <i>Fruit</i> ...	52	257	“ “ <i>New York.</i>	174	1,750
“ “ “ <i>Milk</i> ...	56	267	“ <i>Slack-adjusters</i>	176	1,761
“ “ “ <i>Refrigerator.</i>	58	274	Doors, Passenger and Baggage.	177	1,783
“ “ <i>Flat-cars.</i>	62	287	“ <i>Freight.</i>	178	1,794
“ “ <i>Gondola-cars</i> . .	64	298	“ <i>Grain.</i>	181	1,866
“ “ <i>Side Dump-cars.</i> ...	70	328	Draft-gear, Freight-car	184	1,936
“ “ <i>Mine-cars.</i>	75	343	“ <i>Draw-bar Attachments.</i>	186	2,007
“ “ <i>English Wagon.</i>	76	348	“ <i>Draw-bars and Couplers.</i> ...	189	2,073
“ “ <i>Logging-cars.</i>	77	352	“ <i>Passenger-car.</i>	198	2,275
“ “ <i>Stock-cars</i> ...	78	355	Roofs, Freight-car.	204	2,325
“ “ <i>Tank-cars</i>	82	373	Signaling Apparatus	208	2,388
“ “ <i>Caboose-cars.</i>	84	380	Sleeping-berths	209	2,408
“ Working, Derrick-cars.	86	389	Vestibules, General Views.	212	2,419
“ “ <i>Pile-driver Cars.</i> ..	88	397	“ <i>Details.</i>	215	2,425
“ “ <i>Shovel-cars.</i>	91	405	Windows.	220	2,451
“ “ <i>Snow-plows.</i>	92	408			

INDEX TO ENGRAVINGS.

CAR-FURNISHINGS:	PAGE.	FIG.
Bell Cord, <i>Bushings</i>	221	2,454
" <i>Couplings and Splices</i>	221	2,464
" <i>Guides</i>	221	2,476
" <i>Hangers</i>	222	2,503
" <i>Hanger Straps</i>	223	2,527
Door, <i>Bolts, etc</i>	223	2,535
" <i>Hooks and Catches</i>	224	2,551
" <i>Hinges</i>	225	2,586
" <i>Knobs and Escutcheons</i>	226	2,621
" <i>Locks</i>	227	2,644
" <i>Freight-car Locks</i>	230	2,736
" <i>Padlocks</i>	231	2,760
" <i>Notice Plates</i>	232	2,773
" <i>Stops and Weather-strips</i>	233	2,803
" <i>Sliding-door Fixtures</i>	234	2,825
Floor.....	235	2,852
Heating Apparatus, <i>Baker's</i>	236	2,865
" " <i>The Consolidated</i>	240	2,959
" " <i>Gold's</i>	243	2,996
" " <i>Safety's</i>	247	3,023
" " <i>Speur's</i>	251	3,058
" <i>Stoves and Ranges</i>	251	3,061
Lamps, <i>Gas, The Frost System</i>	253	3,109
" <i>The Pintsch System</i>	259	3,160
Lamps, <i>Oil</i>	263	3,252
" <i>Combination, for Street-cars</i>	270	3,308
" <i>Tail and Caboose Lamps</i>	271	3,318
Lamp Brackets and Lanterns.....	272	3,333
" <i>Burners</i>	273	3,363
" <i>Chimneys and Shades</i>	275	3,412
Lavatory, <i>Furnishings</i>	277	3,468
" <i>Pumps and Faucets, etc</i>	278	3,481
" <i>Furnishings</i>	279	3,495
" <i>Wash-bowls, etc</i>	281	3,525
" <i>Air-pressure System of Water Supply</i>	282	3,534
" <i>Water-coolers</i>	284	3,549
" <i>Towel-rod Brackets, etc</i>	284	3,558
Miscellaneous Furnishings:		
" <i>Grilles and Panels</i>	286	3,624
" <i>Hat-hooks, etc</i>	287	3,666
" <i>Sundries</i>	288	3,695
" <i>Jacks</i>	289	3,728
" <i>Lacks, Basket</i>	290	3,753
Platform Furnishings.....	291	3,771
" " <i>Gates</i>	292	3,794
Postal-car Furnishings	293	3,814
Saloon Furnishings	294	3,838
Seals.....	296	3,877
Seats, <i>Bushnell's</i>	297	3,901
Seats, <i>Hale & Kilburn's</i>	299	3,917
" <i>Robert's Woven Wire</i>	303	3,952
" <i>Scarritt's</i>	305	3,968
" <i>Wakefield Rattan</i>	307	3,980
" <i>Chairs and Springs</i>	308	3,990
" <i>Hardware</i>	310	4,022
Sofa and Sleeping-berth	313	4,116
Smoking-room.....	318	4,273

FURNISHINGS, <i>Continued.</i>	PAGE.	FIG.
Table Plates and Hooks	319	4,286
Ventilators.....	319	4,300
Windows, <i>Deck</i>	321	4,330
" <i>Blinds</i>	323	4,403
" <i>Lower, and Door</i>	324	4,450
" <i>Shades</i>	327	4,544
TRUCKS, <i>Freight-car, General Views</i>	329	4,576
" " <i>Rigid Diamond and Details</i>	330	4,580
" " <i>Swing-motion</i>	335	4,740
" " <i>Miscellaneous Types</i>	336	4,747
" <i>Passenger, Four-wheeled and Details</i>	340	4,806
" " <i>Six-wheeled and Details</i>	347	4,962
TRUCK DETAILS (<i>with each style of Truck</i>):		
" <i>Journal Boxes and Lids</i>	350	5,133
" <i>Bolster Springs</i>	352	5,192
" <i>Equalizer and Elliptic</i>	354	5,223
" <i>Wheels, Steel-tired</i>	357	5,255
" <i>Wheel Tire Fastenings</i>	362	5,337
" <i>Chilled Cast Wheels</i>	363	5,343
" <i>Wheels, Contracting Chills</i>	364	5,364
MASTER CAR BUILDERS' STANDARDS:		
Journal Boxes, <i>etc</i>	365	5,377
Bearings and Wedges.....	367	5,389
Axles and Wheel Gage.....	368	5,419
Brake-gear.....	369	5,425
Pedestal.....	370	5,480
Wheel and Track Gages	371	5,484
Screw Threads	372	5,490
Coupler.....	373	5,499
MASTER CAR BUILDERS' RECOMMENDED PRACTICE:		
" <i>Attachment of Coupler</i>	373	5,506
" <i>Marking Freight-cars</i>	374	5,543
" <i>Protection of Trainmen</i>	374	5,546
" <i>Freight Safety-chains</i>	375	5,552
" <i>Bearing and Wedge Gages</i>	375	5,556
" <i>Loading Poles and Bark</i>	375	5,572
" <i>Defect Card for Air-brake</i>	376	5,577
" <i>Dummy Coupling Hook</i>	376	5,579
HAND-CARS, <i>General Views</i>	377	5,581
" <i>Working Drawings</i>	378	5,592
PUSH-CARS, <i>General Views</i>	380	5,601
VELOCIPEDA-CARS, <i>General Views</i>	380	5,605
" <i>Mine and Tunnel</i>	381	5,617
" <i>Wheels</i>	382	5,620
WAREHOUSE TRUCKS.....	382	5,636
STREET-CARS, <i>General Views</i>	383	5,642
" <i>Detail Drawings</i>	387	5,654
STREET-CAR TRUCKS.....	391	5,668
STREET-CAR MOTORS	392	5,674

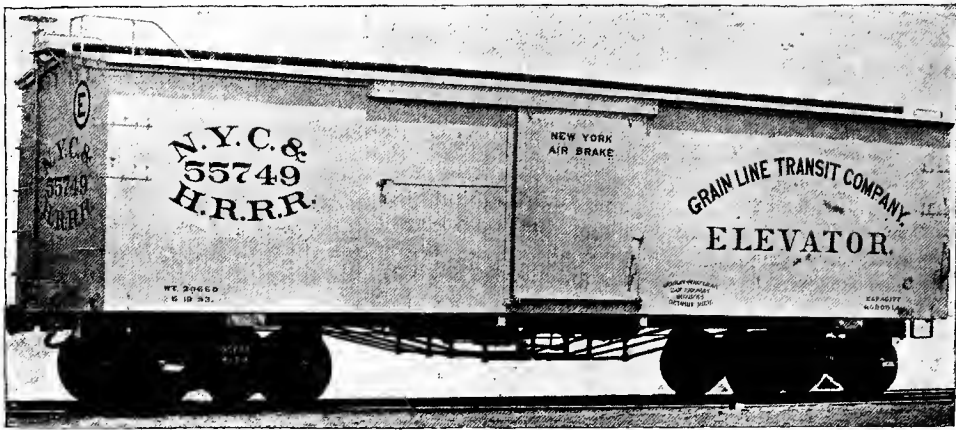

Fig. 1. BOX CAR. NEW YORK CENTRAL & HUDSON RIVER RAILROAD.
Capacity, 60,000 lbs. Weight, 30 650 lbs.
Inside End Sills, Brake Hand Rail, and Equipped with Air Brakes and For Trucks.
(Details are shown in Figs. 227-231.)

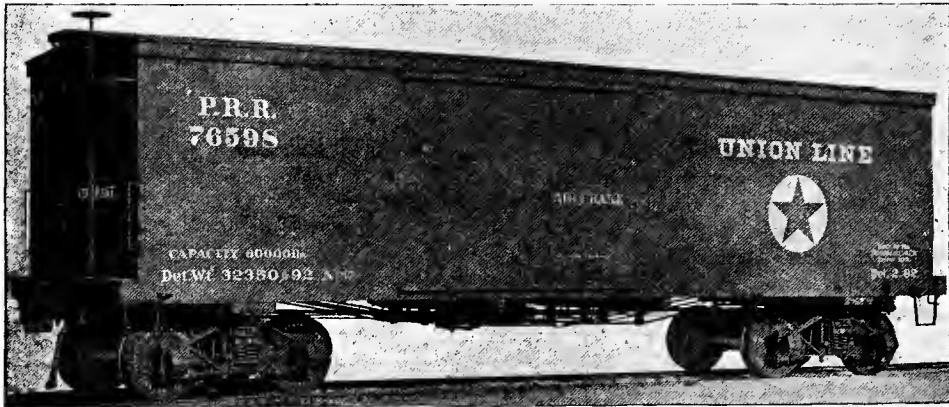

Fig. 2. BOX CAR. PENNSYLVANIA RAILROAD.
Length, 39 ft. Capacity, 60,000 lbs. Weight, 32,350 lbs.
Outside End Sill. Equipped with Air Brakes and Rigid Diamond Trucks. (Details are shown in Figs. 232-243.)

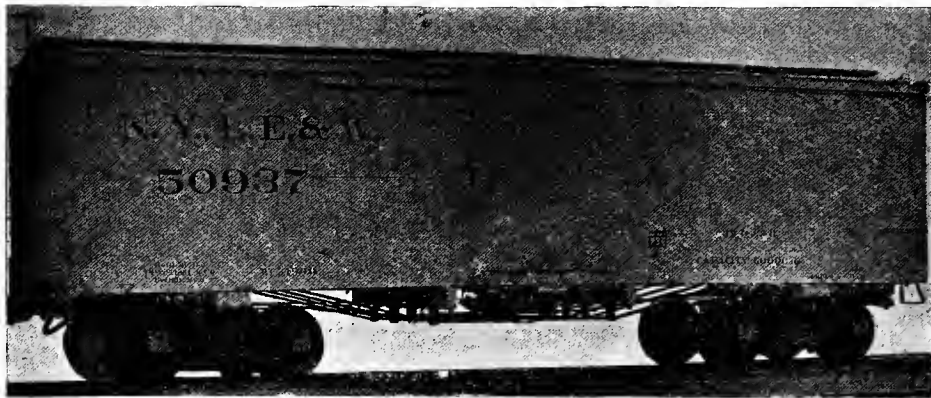

Fig. 3. BOX CAR. NEW YORK, LAKE ERIE & WESTERN RAILROAD.
Length, 34 ft. Capacity, 60,000 lbs. Weight, 31,000 lbs.
Equipped with Air Brakes and Rigid Diamond Trucks.

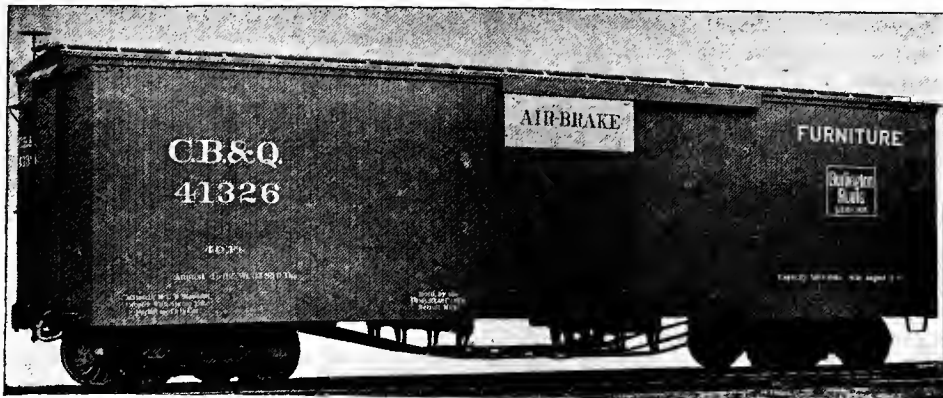

Fig. 4. FURNITURE CAR. CHICAGO, BURLINGTON & QUINCY RAILROAD.
Length, 40 ft. Capacity, 50,000 lbs. Weight, 31,850 lbs.
Coupler is placed between Center Sills to get greater height of Car-body. (Details are shown in Figs. 247-250.)



Fig. 5. FRUIT CAR. NORFOLK & WESTERN RAILROAD.
Length, 34 ft. 8 ins. Capacity, 65,000 lbs. Weight, 31,500 lbs.
Grated Doors and Ventilators. Equipped with Rigid Diamond Trucks.

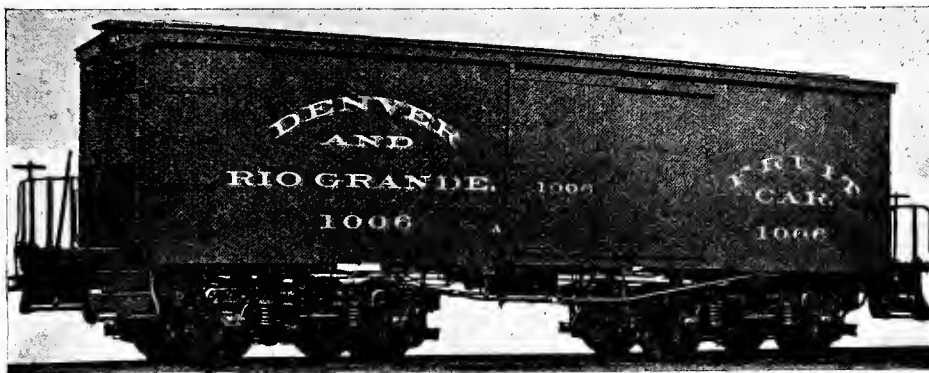

Fig. 6. FRUIT CAR. DENVER & RIO GRANDE RAILROAD.
Length, 34 ft. Capacity, 40,000 lbs. Weight, 43,600 lbs.
Equipped with Platforms and Steps, Passenger Trucks, End Ventilators and Air Brakes.

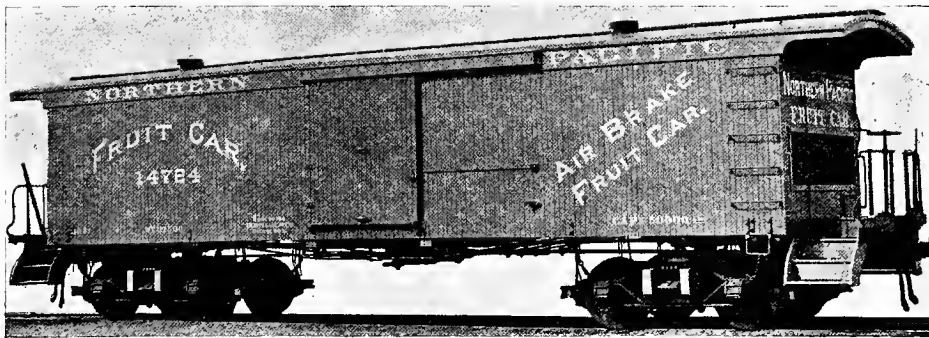

Fig. 7. FRUIT CAR. NORTHERN PACIFIC RAILROAD.
Length, 35 ft. 3 ins. Capacity, 40,000 lbs. Weight, 34,800 lbs.
Ventilated Ends and equipped with Swing Motion Diamond Trucks with Elliptic Springs.



Fig. 8. POULTRY CAR.
Length, 33 ft. 10 ins. Capacity, 16,000 lbs., 5,000 Fowl, 2,000 Geese, or 1,400 Turkeys.
Equipped with Swing Motion Diamond Trucks.

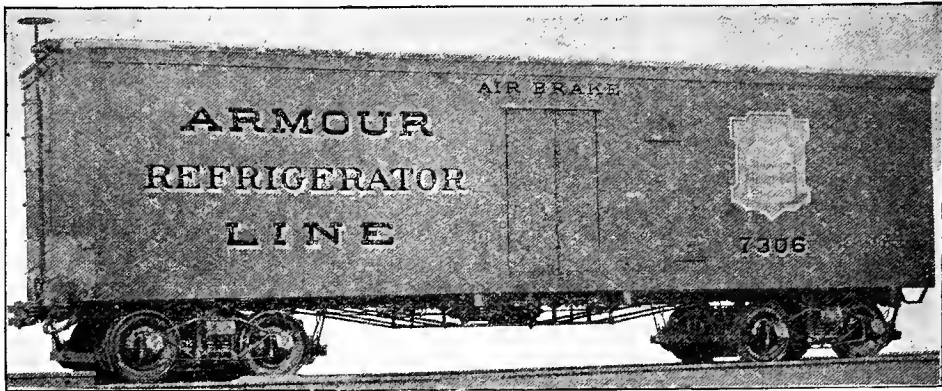

Fig. 9. REFRIGERATOR CAR FOR DRESSED MEAT.
Length, 36 ft. Capacity, 50,000 lbs. Weight, 43,000 lbs.

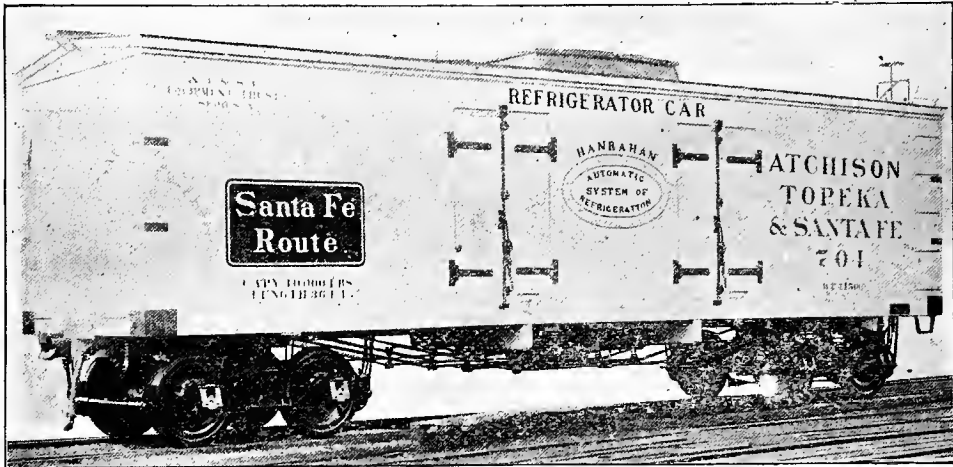

Fig. 10. REFRIGERATOR CAR, ATCHISON, TOPEKA & SANTA FE RAILROAD.
Length, 36 ft. Capacity, 40,000 lbs. Weight, 41,500 lbs.
Hanbahn System of Refrigeration, the details of which are shown in Figs. 274-277.

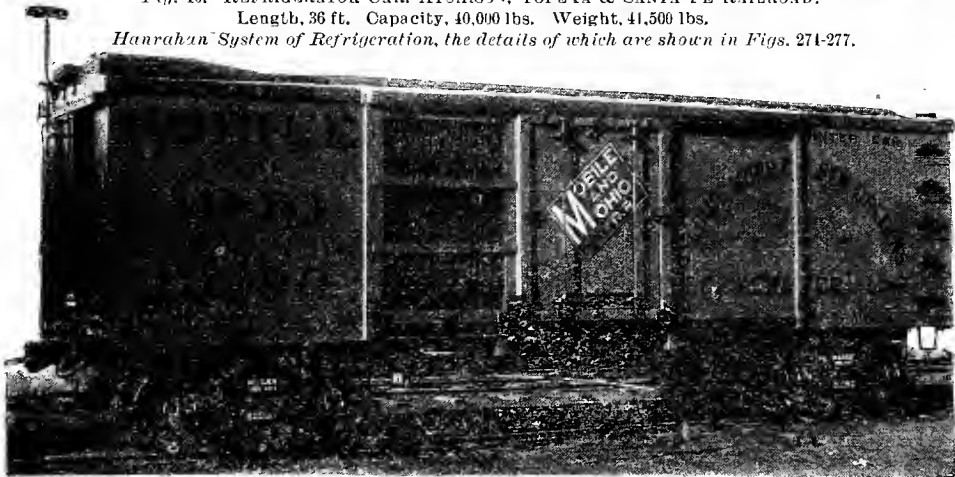

Fig. 11. REFRIGERATOR CAR, MOBILE & OHIO RAILROAD.
Capacity, 40,000 lbs. Weight, 37,400 lbs.

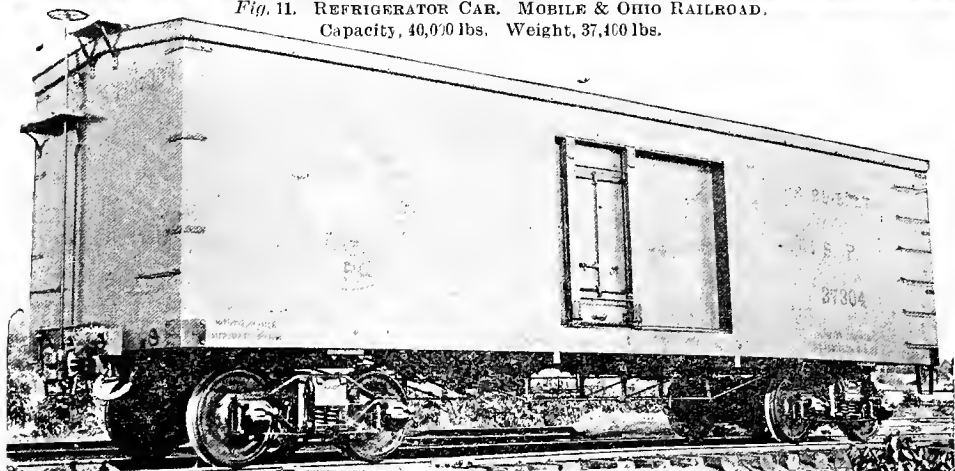

Fig. 12. REFRIGERATOR CAR, SOUTHERN PACIFIC COMPANY.
Length, 36 ft. Capacity, 50,000 lbs. Weight, 40,000 lbs.
Candus System of Refrigeration, details of which are shown in Figs. 283-286.

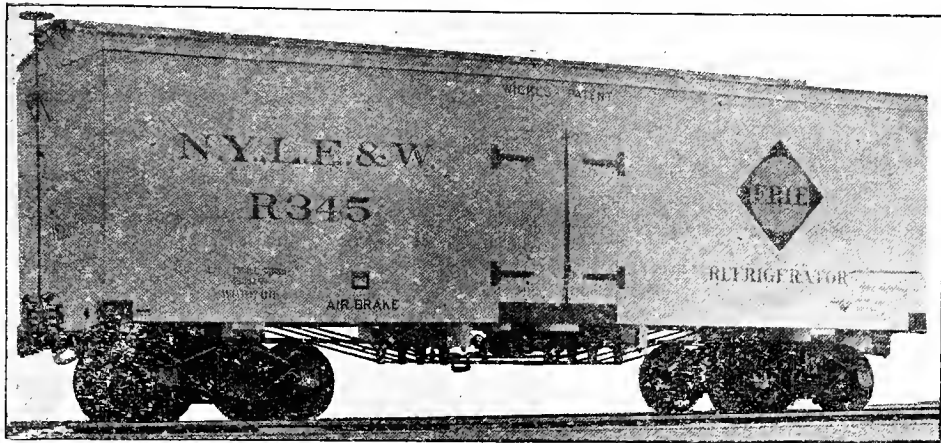

Fig. 13. REFRIGERATOR CAR. NEW YORK, LAKE ERIE & WESTERN RAILROAD.
Length, 34 ft. Capacity, 60,000 lbs. Weight, 39,800 lbs.
Wickes System of Refrigeration. Equipped with Rigid Diamond Trucks and Graham Draft Rigging.
Journals, $4\frac{1}{4} \times 8$ ins.

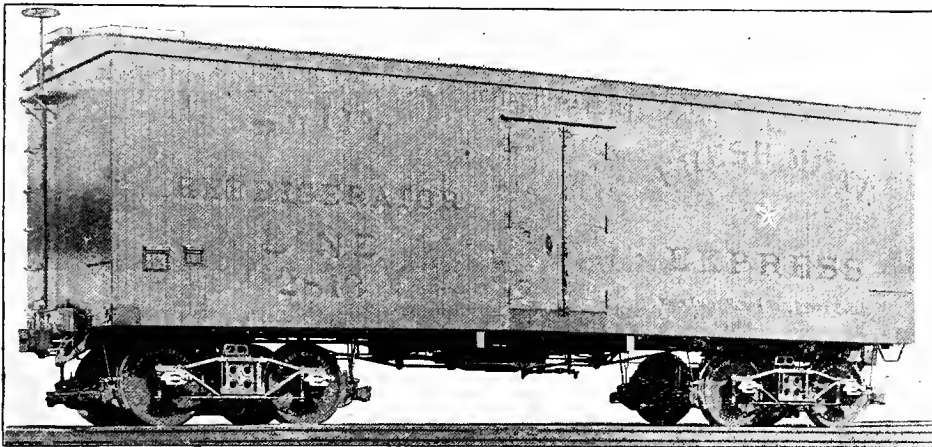

Fig. 14. REFRIGERATOR CAR FOR DRESSED MEATS. SWIFT REFRIGERATOR LINE.
Chase System of Refrigeration. Equipped with Swing Motion Diamond Trucks.

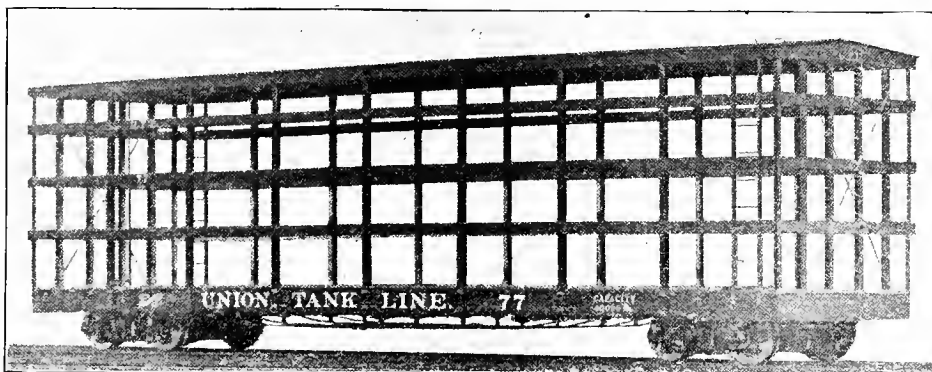

Fig. 15. BARREL CAR. UNION TANK LINE.
Length, 51 ft. Capacity, 432 barrels, or 40,000 lbs.



Fig. 16. FLAT CAR. SAGINAW, TUSCOLA & HURON RAILROAD.
Length, 36 ft. Capacity, 60,000 lbs. Weight, 20,050 lbs.
Equipped with Pull up Brake, Aldrich Brake Wheel and Swing Motion Diamond Trucks.

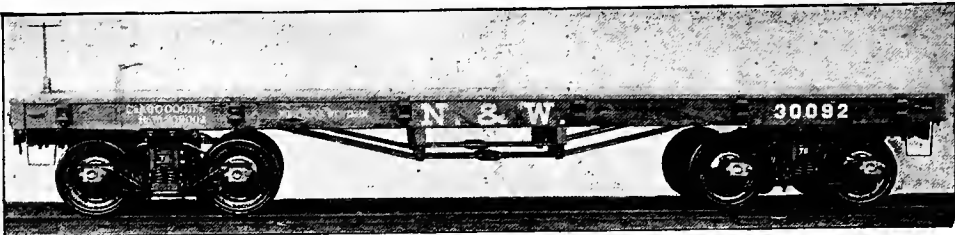

Fig. 17. FLAT CAR NORFOLK & WESTERN RAILROAD.
Length, 34 ft. Capacity, 60,000 lbs. Weight, 20,900 lbs.
Equipped with Rigid Diamond Trucks.



Fig. 18. FLAT CAR. DAVENPORT, IOWA & DAKOTA RAILROAD.
Length, 34 ft. Capacity, 40,000 lbs. Weight, 17,700 lbs.
Equipped with Rigid Diamond Trucks.



Fig. 19. FLAT CAR, FOR BRIDGE TIMBERS.
Length, 41 ft. Capacity, 60,000 lbs. Weight, 23,700 lbs.
Equipped with Rigid Diamond Trucks (Details are shown in Figs. 294-297.)

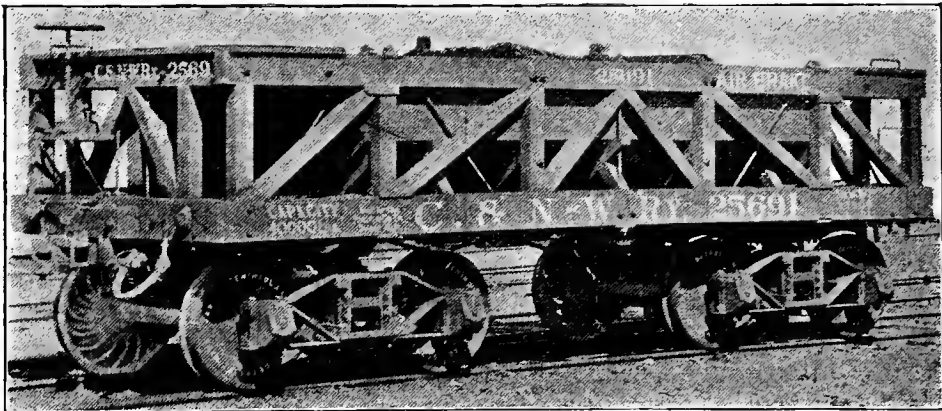

Fig. 20. ORE CAR. CHICAGO & NORTH WESTERN RAILWAY.
Length, 22 ft. Capacity, 40,000 lbs. Weight, 23,800 lbs.
Equipped with Air Brakes and Swing Motion Trucks.

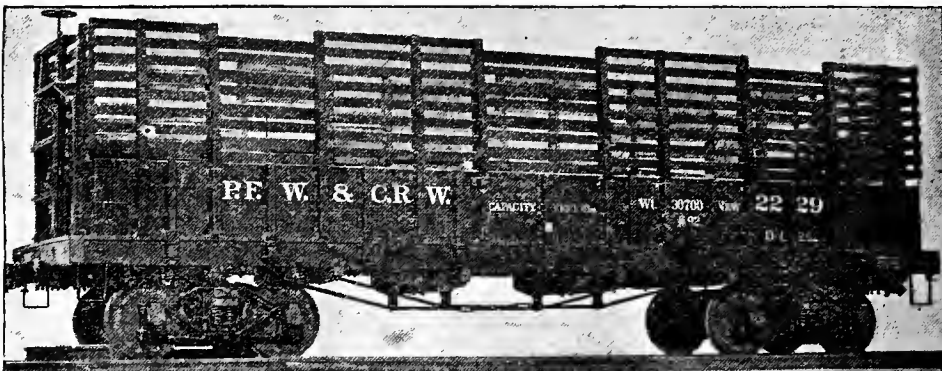

Fig. 21. GONDOLA CAR, WITH DOUBLE DROP BOTTOM AND RACK FOR COKE. PITTSBURGH, FORT WAYNE & CHICAGO RAILWAY.
Inside length, 33 ft. Capacity, 60,000 lbs. Weight, 30,700 lbs.

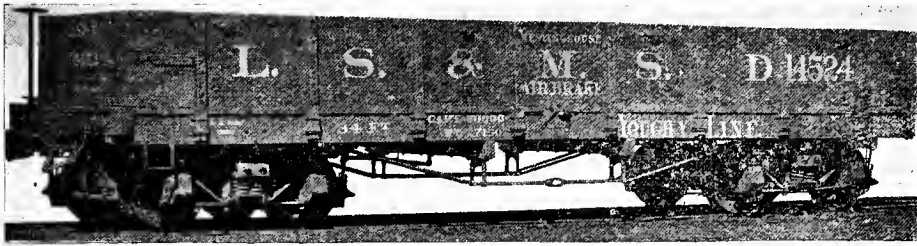

Fig. 22. GONDOLA CAR, SINGLE DROP-BOTTOM, FOR COAL AND LUMBER.
LAKE SHORE & MICHIGAN SOUTHERN RAILWAY.
Length, 34 ft. Capacity, 60,000 lbs. Weight, 27,150 lbs.
Equipped with Air Brakes and Rigid Diamond Trucks.



Fig. 23. GONDOLA CAR, WITH DROP-BOTTOM AND DROP-ENDS, FOR COAL, ORE AND LUMBER
NORFOLK & WESTERN RAILROAD.
Length, 36 ft. 1 in. Capacity, 60,000 lbs. Weight, 27,400 lbs.
(Details are shown in Figs. 302-304.)

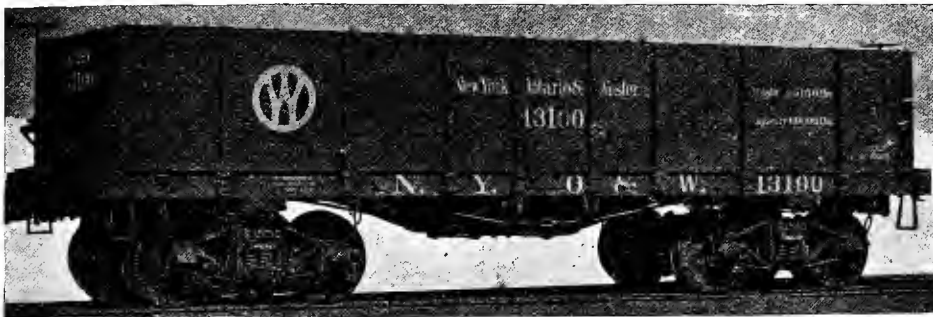

Fig. 24. GONDOLA CAR, WITH HOPPER-BOTTOM, FOR COAL.
NEW YORK, ONTARIO & WESTERN RAILWAY.
Length, 29 ft. 1 in. Capacity, 60,000 lbs. Weight, 25,150 lbs.



Fig. 25. GONDOLA CAR, WITH PYRAMIDAL HOPPER-BOTTOM, FOR COAL.
Length, 26 ft. Capacity, 60,000 lbs. Weight, 23,400 lbs.
Equipped with Air Brake, Side Trussing and Rigid Diamond Trucks.



Fig. 26. GONDOLA CAR, WITH TWIN-HOPPERS, FOR COAL.
BALTIMORE & OHIO RAILROAD.
Length, 36 ft. 2 ins. Capacity, 60,000 lbs. Weight, 30,800 lbs.



Fig. 27. SIDE-DUMP ORE CAR. LAKE SHORE & MICHIGAN SOUTHERN RAILWAY.
Length, 32 ft. Capacity, 80,000 lbs. Weight, 36,500 lbs.
(Details are shown in Figs. 332-335.)

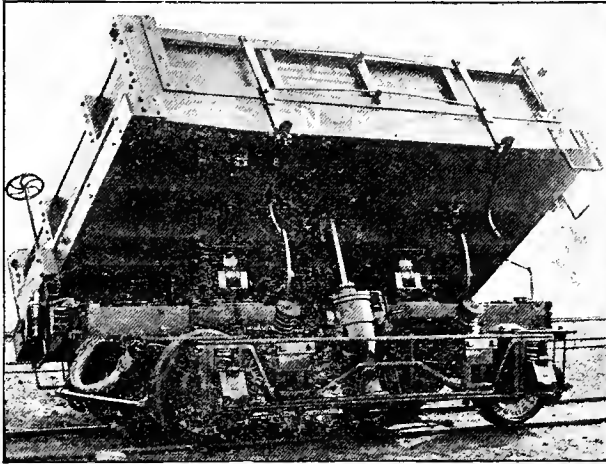

Fig. 28. SIDE-DUMP CAR, THACHER.
Capacity, 40,000 lbs. Weight, 17,200 lbs.
Body tilted by Compressed Air. (Details are shown in Figs. 339-342.)

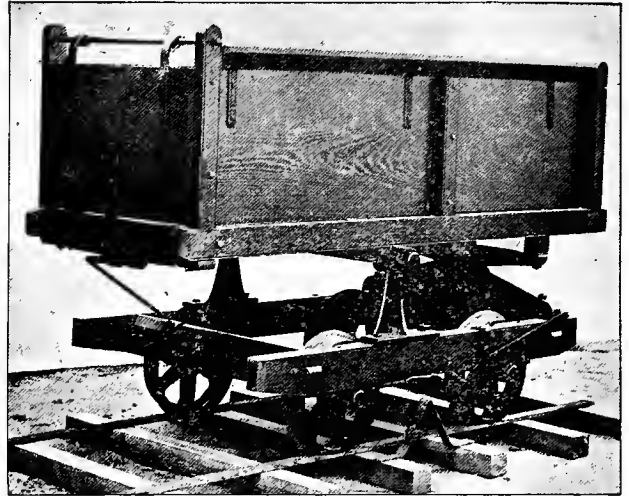

Fig. 29. MINE CAR, AUTOMATIC END DUMP, BUILT BY
C. W. RAYMOND & CO.

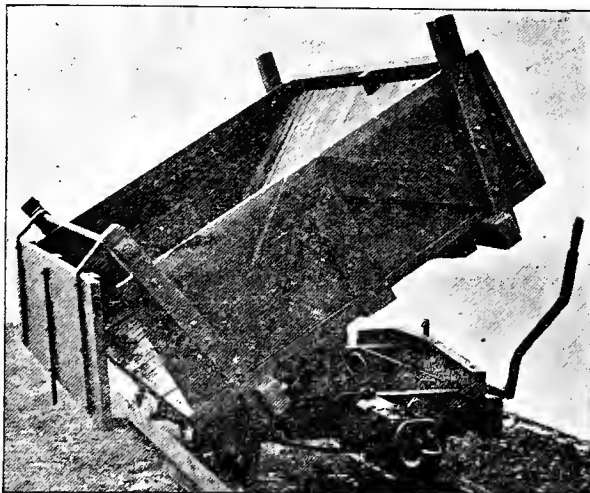

Fig. 30. MINE CAR, AUTOMATIC SIDE DUMP, BUILT BY
C. W. RAYMOND & CO.

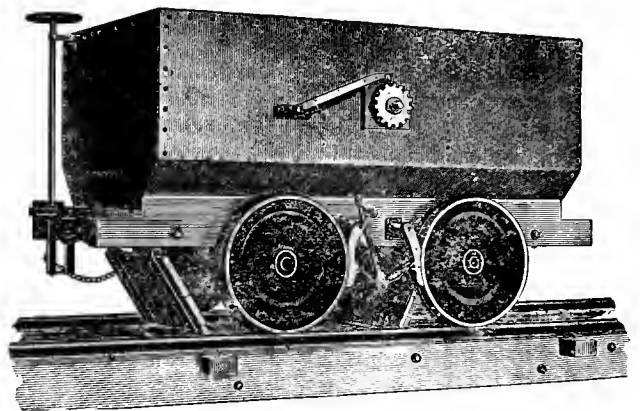

Fig. 31. CEMENT CAR, DROP BOTTOM, BUILT BY
BLOOMSBURG CAR COMPANY.

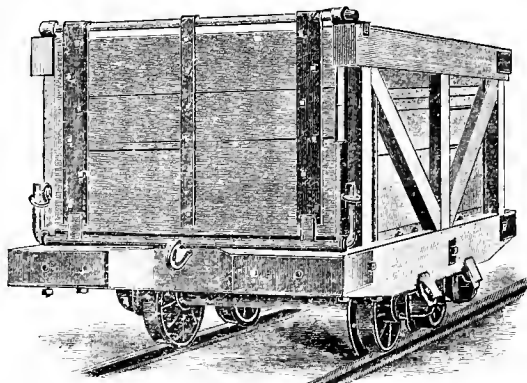

Fig. 32. MINE CAR, END DUMP, BUILT BY
BLOOMSBURG CAR COMPANY.

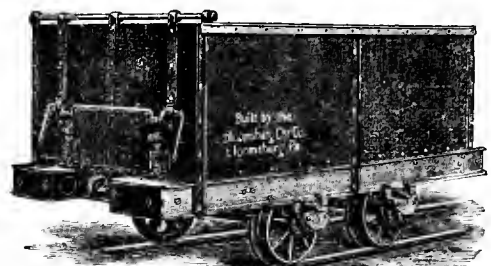

Fig. 33. MINE CAR, STEEL, END DUMP, BUILT BY
BLOOMSBURG CAR COMPANY.

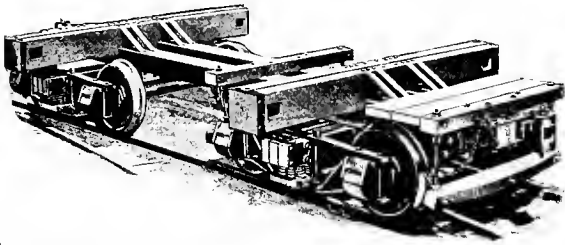

Fig. 34. LOGGING CAR, BUILT BY THE RUSSELL WHEEL & FOUNDRY COMPANY.

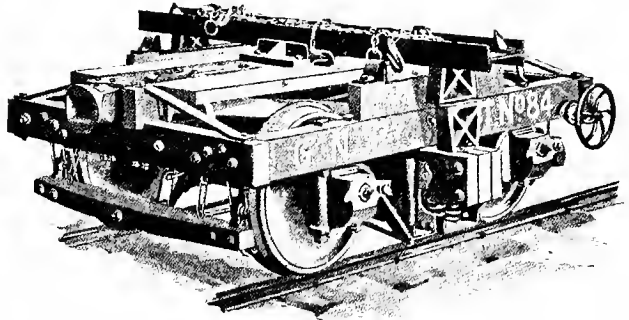

Fig. 35. LOGGING CAR TRUCK, BUILT BY THE RUSSELL WHEEL & FOUNDRY COMPANY.

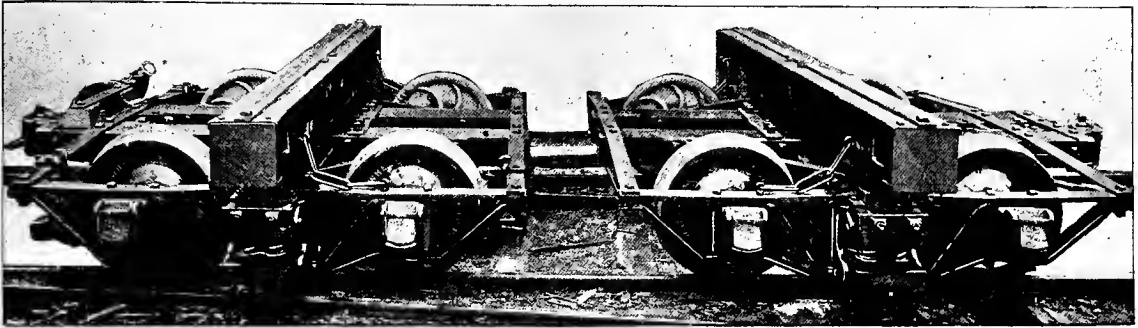

Fig. 36. LOGGING CAR, BUILT BY THE RUSSELL WHEEL & FOUNDRY COMPANY. Truck length, 8 ft. 4 ins. Height, 32 ins. Capacity, 50,000 lbs. Weight, 9,400 lbs. (Details are shown in Figs. 352-351.)

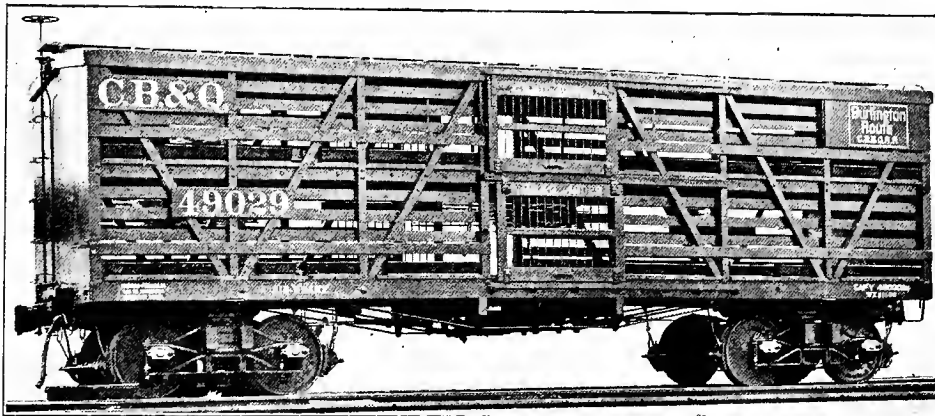

Fig. 37. STOCK CAR, DOUBLE DECKED FOR SHEEP AND HOGS. CHICAGO, BURLINGTON & QUINCY RAILROAD. Capacity, 40,000 lbs. Weight, 31,500 lbs. Equipped with Air Brakes, Troughs for Feeding and Watering and Swing Motion Trucks.

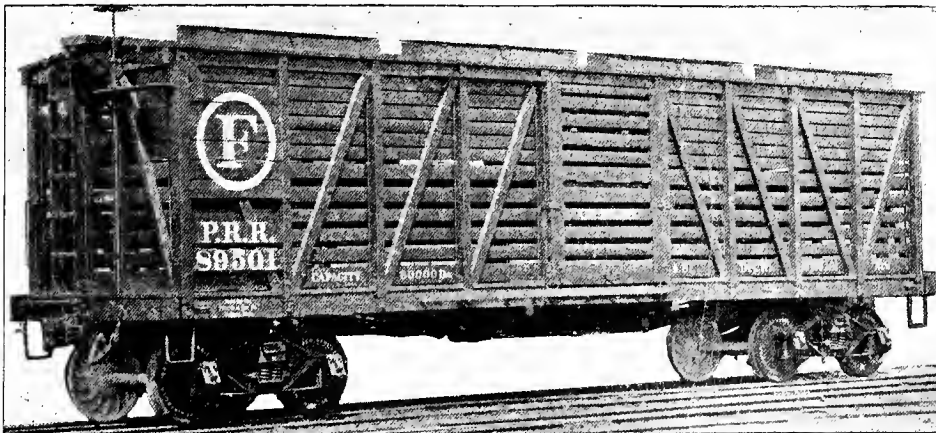

Fig. 38. STOCK CAR FOR CATTLE AND HORSES. PENNSYLVANIA RAILROAD. Capacity, 60,000 lbs. Weight, 30,100 lbs. Equipped with Feed Bores, Air Brakes and Rigid Diamond Trucks.



Fig. 39. STOCK CAR FOR CATTLE AND HORSES. CHICAGO & NORTHWESTERN RAILWAY.
Capacity, 50,000 lbs. Weight 34,550 lbs.
Arrangements for Feeding and Watering, End Doors for Loading Lumber and Rails, and Equipped with Air Brake and Swing Motion Truck.

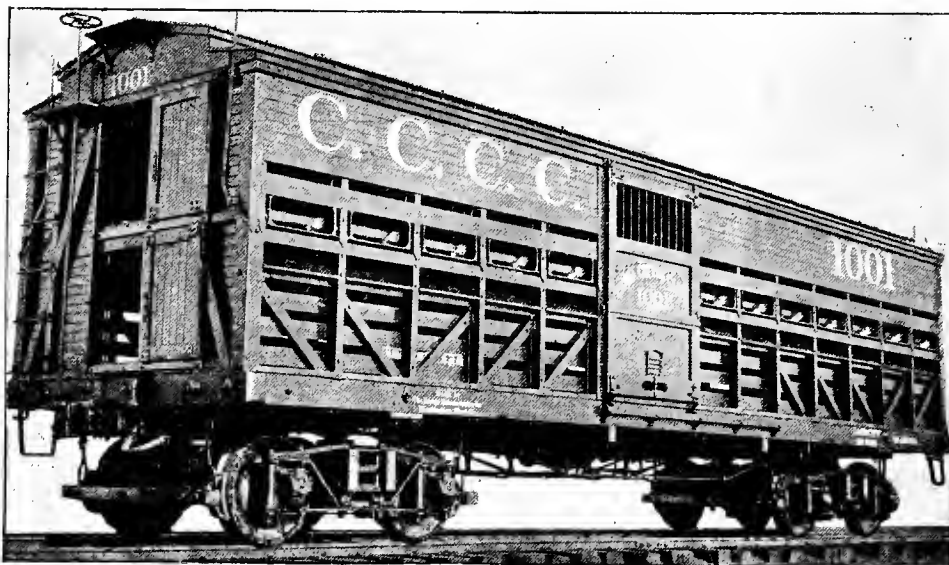

Fig. 40. STOCK CAR FOR CATTLE AND HORSES. CANADA CATTLE CAR COMPANY.
Length, 36 ft. Capacity, 60,000 lbs. Weight, 32,900 lbs.
Arrangements for Feeding and Watering, End Doors for Loading Lumber and Rails, and Equipped with Air Brakes and Special Swing Motion Trucks. (Details are shown in Figs. 339-364.)



Fig. 41. STOCK CAR FOR CATTLE AND HORSES. ATCHISON, TOPEKA, & SANTA FE RAILROAD.
Length, 34 ft. Capacity, 50,000 lbs. Weight, 28,900 lbs.
Arrangements for Feeding and Watering, Equipped with Air Brakes and Swing Motion Trucks.
(Interior shown in Fig. 42.)

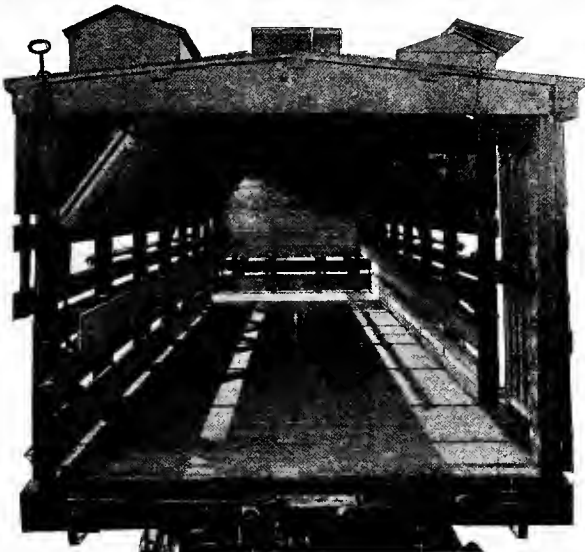

Fig. 42. INTERIOR OF STOCK CAR FOR CATTLE AND HORSES. ATCHISON, TOPEKA & SANTA FE RAILROAD. Showing Racks and Troughs for Feeding and Watering.

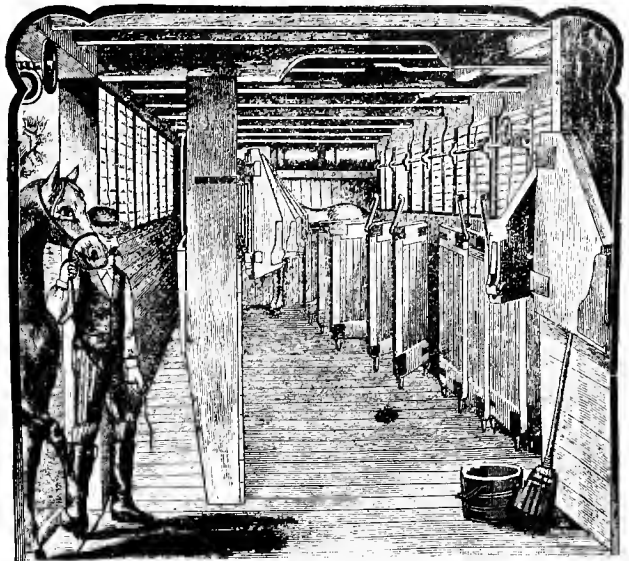

Fig. 43. INTERIOR OF STOCK CAR FOR HORSES. KEYSTONE PALACE HORSE CAR COMPANY. Capacity, 18 horses.

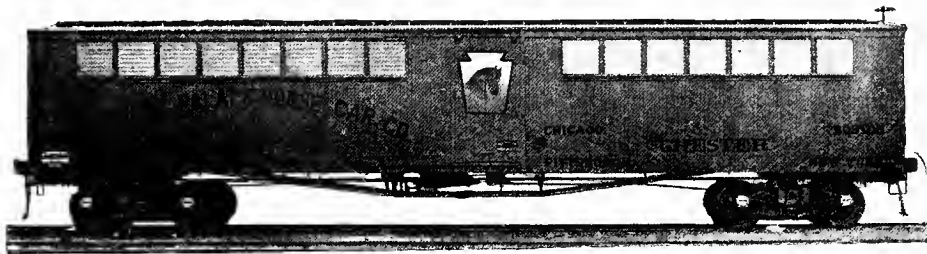

Fig. 44. STOCK CAR FOR HORSES AND PRIZE CATTLE. Equipped with Air Brakes and Swing Motion Trucks. (Interior shown in Fig. 43.)



Fig. 45. STOCK CAR FOR HORSES AND PRIZE CATTLE. THE BURTON STOCK CAR COMPANY. Length, 44 ft. Capacity, 16 horses, or 22,400 lbs. (Interiors shown in Figs. 46 and 47.)

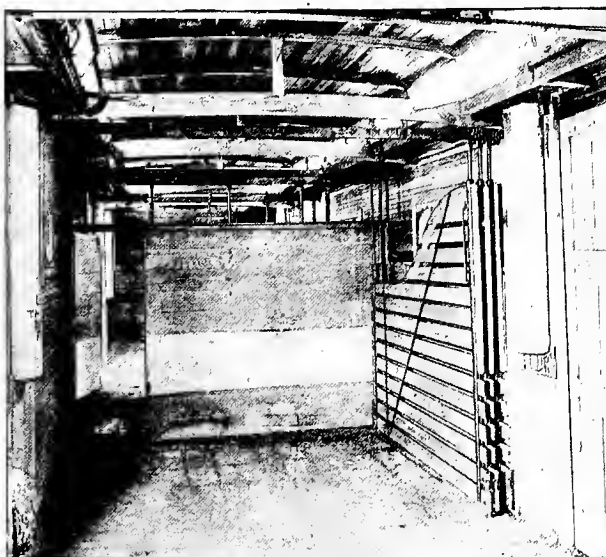

Fig. 46. INTERIOR OF BURTON STOCK CAR FOR HORSES. Partitions moved to one side, making a Box Stall or Storage Room for Vehicles. (11)

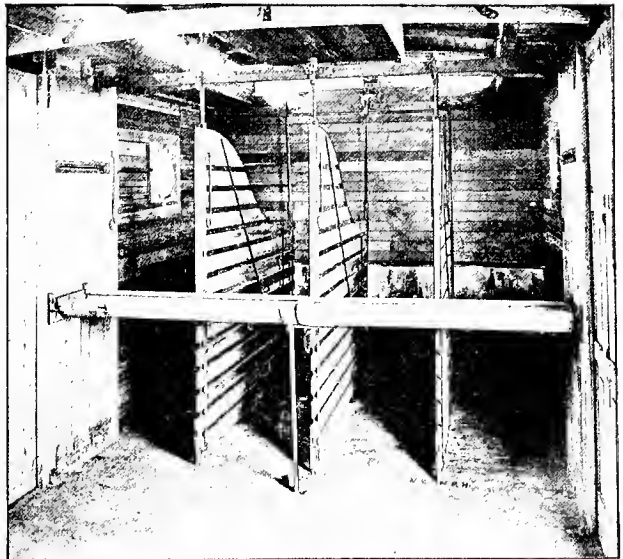

Fig. 47. INTERIOR OF BURTON STOCK CAR FOR HORSES. Partitions arranged longitudinally. Trough when lowered constitutes a Buffer.

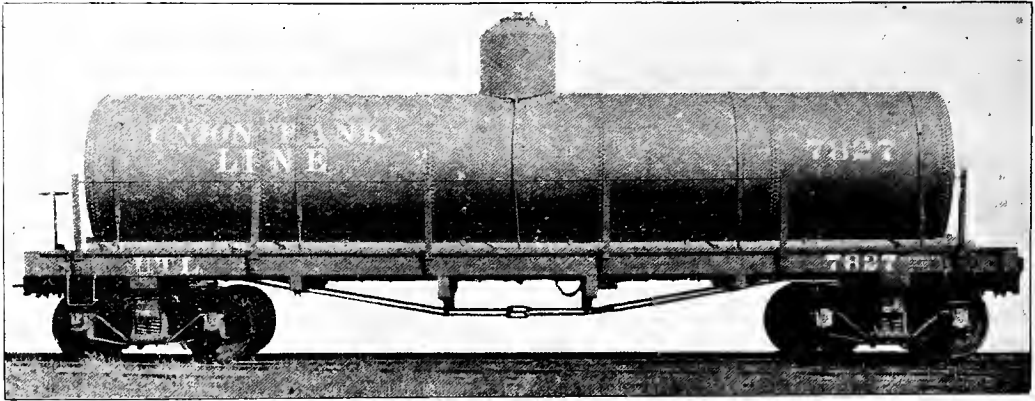

Fig. 48. TANK CAR FOR OIL, ACIDS, MOLASSES, ETC. UNION TANK LINES.
Length, 37 ft. Capacity, 8,000 gals. Weight, 28,000 lbs.
(Details are shown in Figs. 373-375.)



Fig. 49. *End View.*
TANK CAR FOR OIL, ACIDS, ETC. UNION TANK LINE.

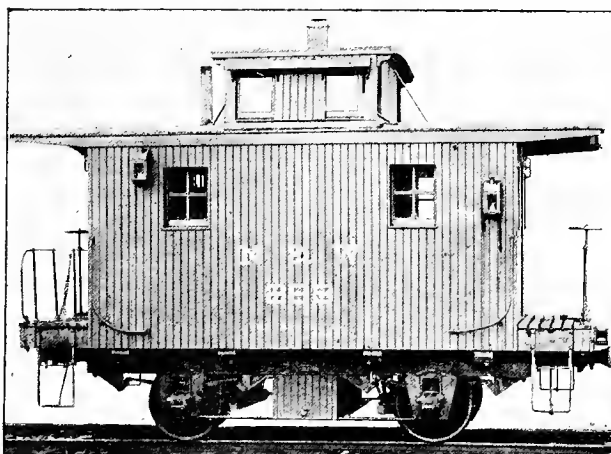

Fig. 50. CABOOSE CAR NORFOLK & WESTERN RAILROAD.
Four-Wheeled. With Lookout and Tool Box.

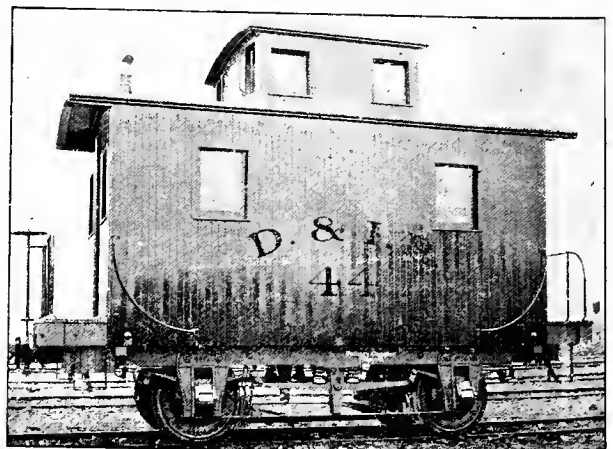
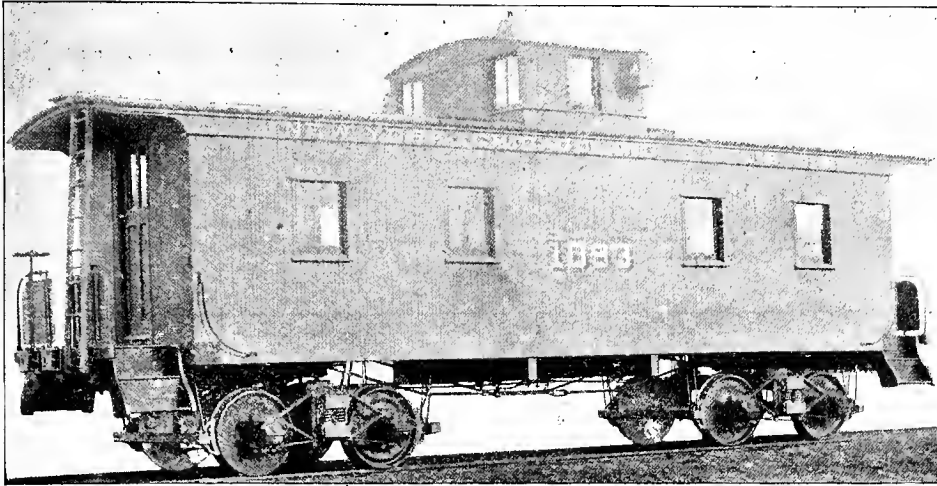
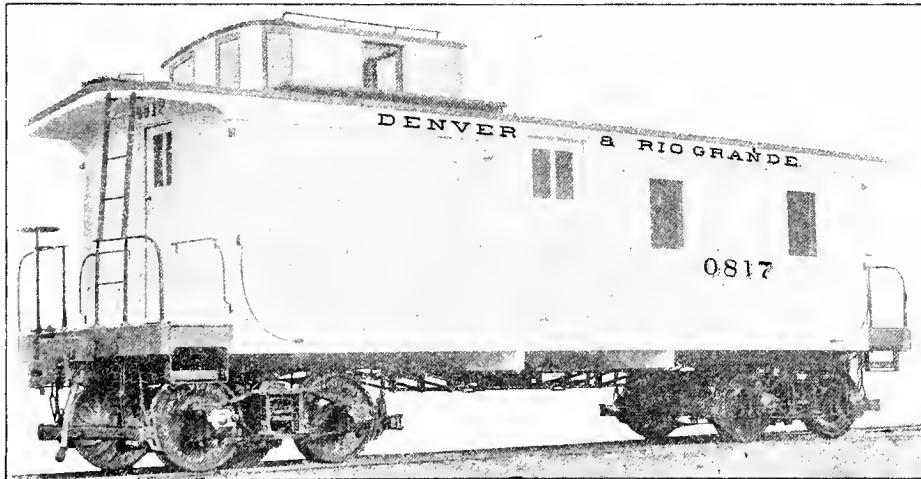

Fig. 51. CABOOSE CAR WITH EQUALIZING BAR.
DULUTH & IRON RANGE RAILROAD.
Four-Wheeled. With Lookout. (Older Pattern.)



*Fig. 52. CABOOSE CAR. NEW YORK, CHICAGO & ST. LOUIS RAILROAD.
With Lookout, Platforms, Steps and Rigid Diamond Trucks.*



*Fig. 53. CABOOSE CAR. DENVER & RIO GRANDE RAILROAD.
With Lookout Side Doors, and Swing Motion Diamond Trucks with Elliptic Springs.*

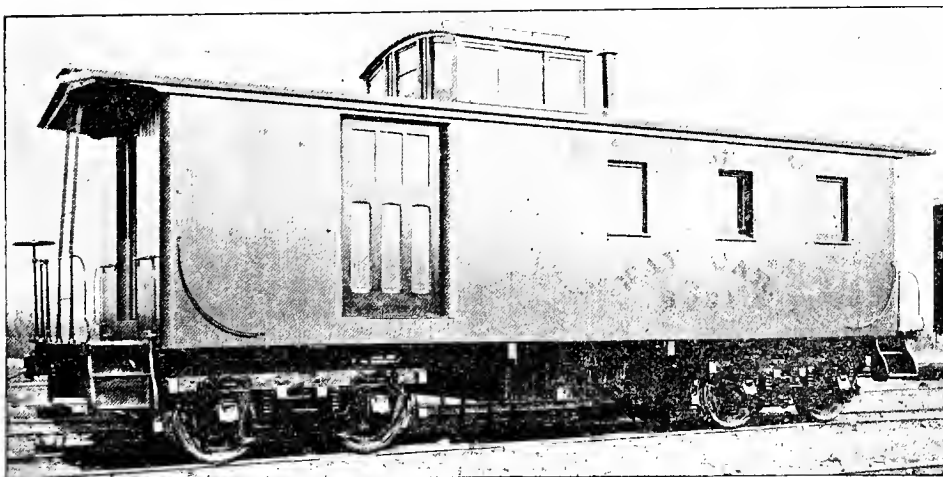

*Fig. 54. CABOOSE CAR. CHICAGO, ST. PAUL, MINNEAPOLIS & OMAHA RAILWAY.
With Lookout, Tool Box, Platforms and Steps, Side Doors and Passenger Trucks.*

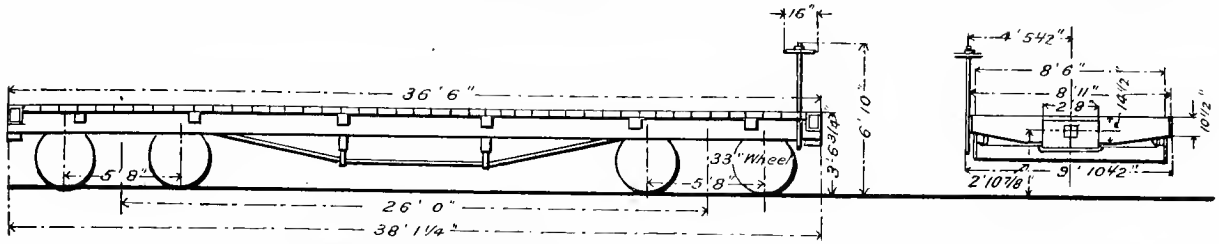

Fig. 63. Side Elevation.

LOW FLAT CAR, BALTIMORE & OHIO RAILROAD.
Length over couplers, 38 ft. 1 1/4 ins. Capacity, 60,000 lbs.

Fig. 61. End Elevation.

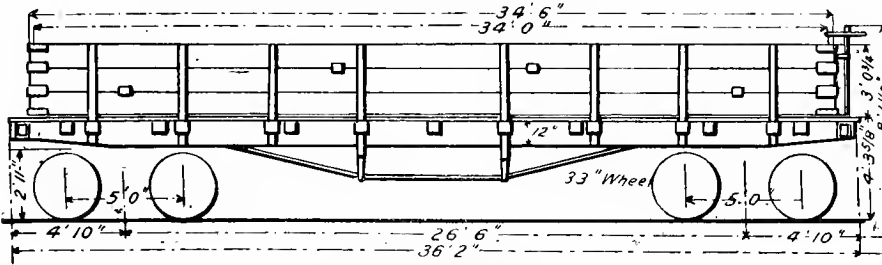

Fig. 65. Side Elevation.

GONDOLA CAR, BALTIMORE & OHIO RAILROAD.
Length over couplers, 38 ft. 5 1/2 ins. Capacity, 60,000 lbs.
American Continuous Drawbar.

Fig. 66. End Elevation.

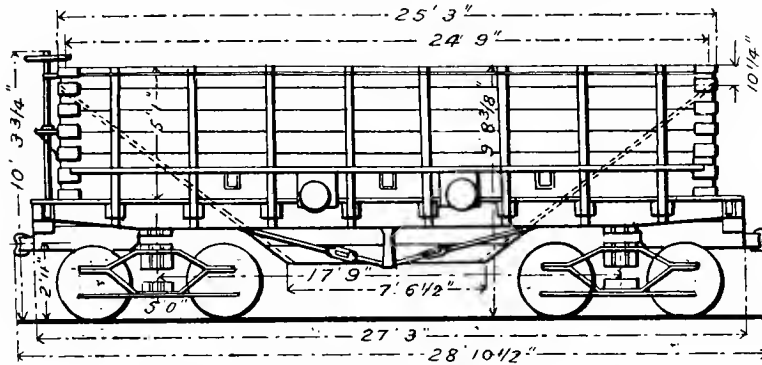

Fig. 67. Side Elevation.

BOX HOPPER GONDOLA CAR, BALTIMORE & OHIO RAILROAD.
Capacity, 60,000 lbs. Weight, 29,700 lbs.
Clear opening of each hopper, 45 x 76 ins.

Fig. 68. End Elevation.

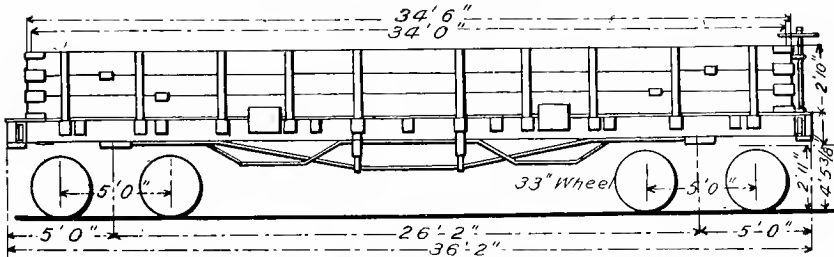

Fig. 69. Side Elevation.

DOUBLE-HOPPER GONDOLA CAR, BALTIMORE & OHIO RAILROAD.
Length, 38 ft. 5 1/2 ins. over couplers. Capacity, 60,000 lbs.

Fig. 70. End Elevation.

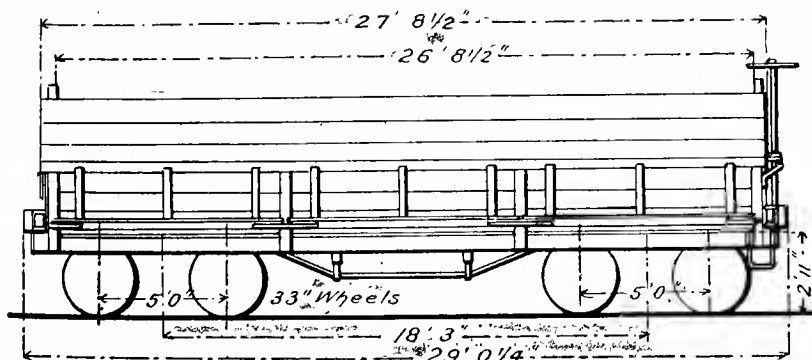

Fig. 71. Side Elevation.

SIDE DUMP CAR, BALTIMORE & OHIO RAILROAD.
Length, 31 ft. 3 3/4 ins. over couplers. Capacity, 60,000 lbs.
American Continuous Drawbar. For Pressed Steel Truck.

Fig. 72. End Elevation.

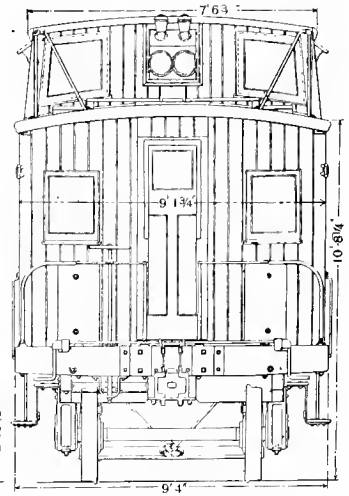
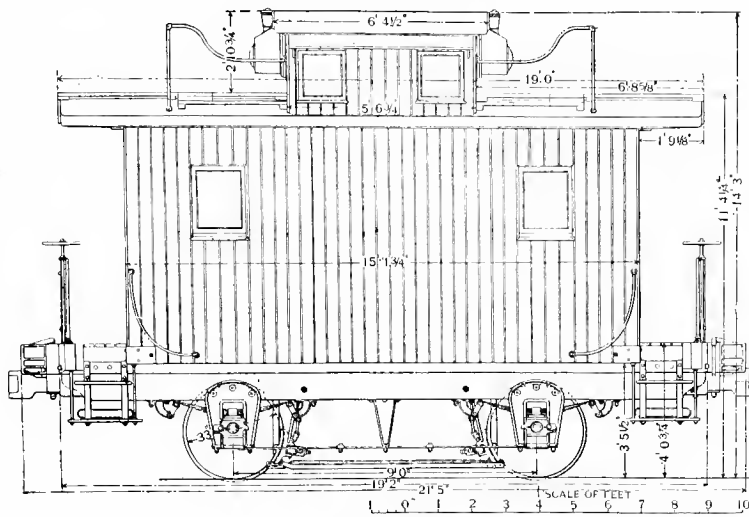

Fig. 81. Side Elevation.

Fig. 82. End Elevation.

FOUR-WHEEL CABOOSE CAR WITH LOOKOUT. NEW YORK, LAKE ERIE & WESTERN RAILROAD.
(Details are shown in Figs. 385-388.)

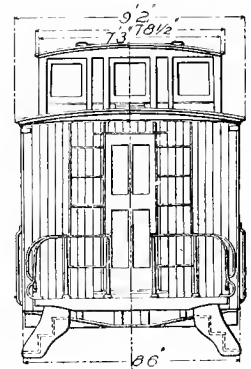
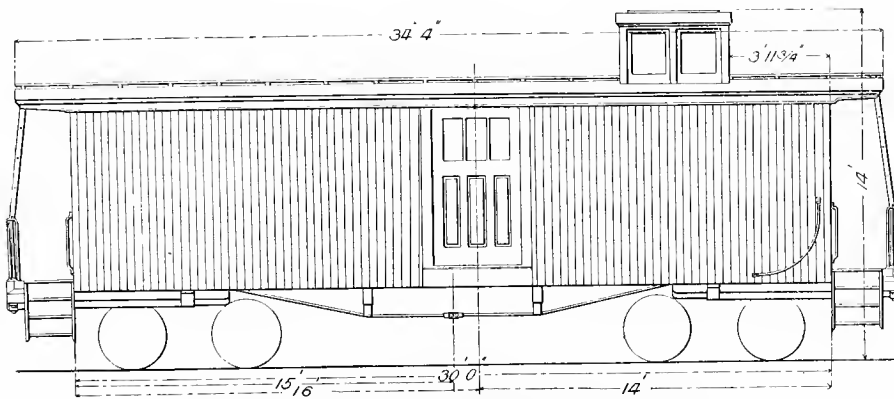

Fig. 83. Side Elevation.

Fig. 84. End Elevation.

EIGHT-WHEEL CABOOSE, WITH SIDE DOORS AND LOOKOUT.

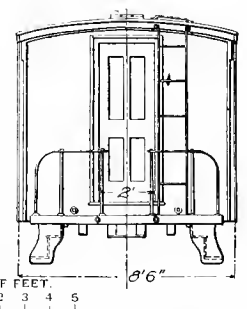
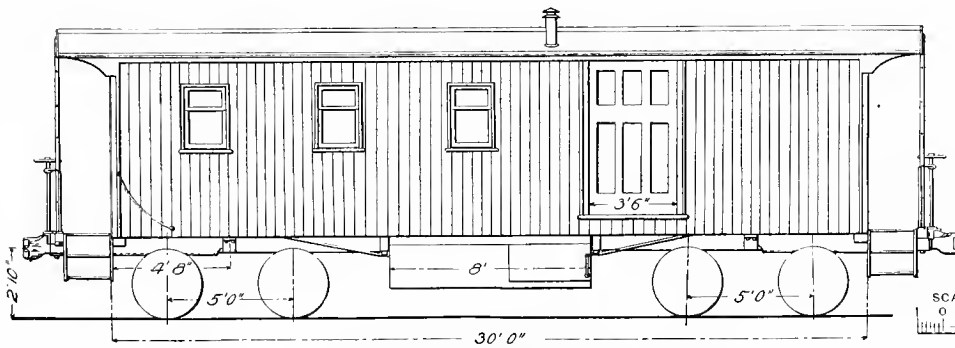

Fig. 85. Side Elevation.

Fig. 86. End Elevation.

EIGHT-WHEEL CABOOSE, WITH SIDE DOORS AND TOOL BOX.

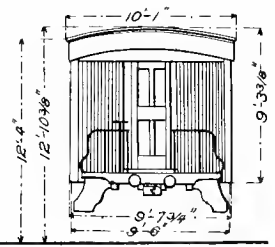
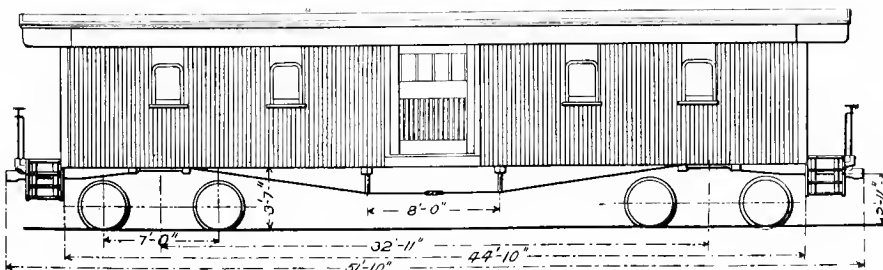

Fig. 87. Side Elevation.

Fig. 88. End Elevation.

EXPRESS CAR. BALTIMORE & OHIO RAILROAD.
Length, 44 ft. Length over all, 51 ft. 10 in.

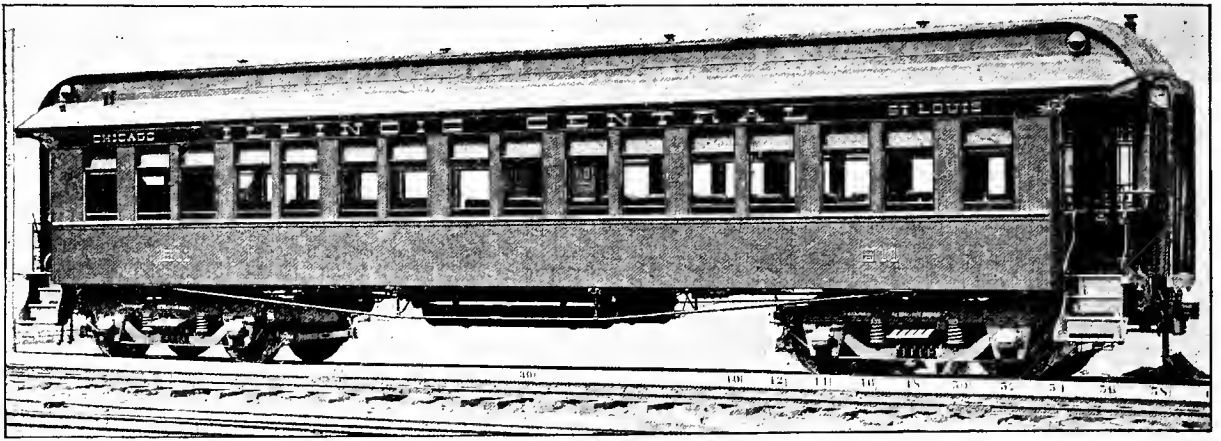

Fig. 89. COACH, FIRST-CLASS, WITH SMOKING COMPARTMENT. ILLINOIS CENTRAL RAILROAD.
Length, 51 ft. 6 ins. Capacity, 56 persons. Weight, 60,900 lbs.



Figs. 90 and 91. INTERIORS OF FIRST-CLASS COACHES.
Pintsch Light.



Fig. 92. COACH, FIRST-CLASS. CHICAGO, BURLINGTON & QUINCY RAILROAD.
(Details of Side and Roof shown in Figs. 557-569.)



Fig. 93. COACH FOR LOCAL OR SUBURBAN SERVICE. ATLANTIC CITY RAILROAD.
(Shown on Transfer Table.)



Fig. 94. INTERIOR OF FIRST CLASS COACH.
Oil Lamps and Window Blinds.



Fig. 95. INTERIOR OF FIRST-CLASS COACH. BOSTON & ALBANY RAILROAD.
Turtle-Back Roof and Bracket Oil Lamps.

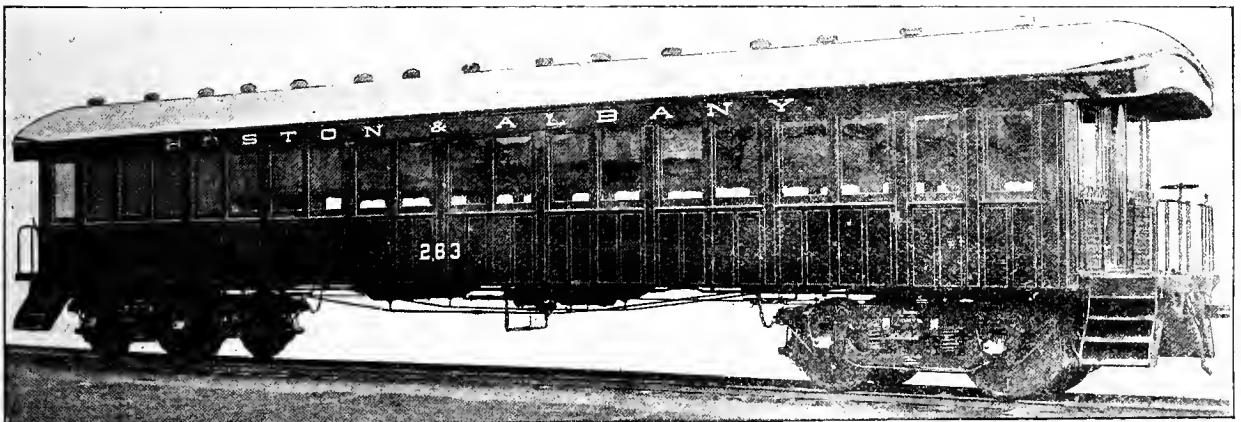

Fig. 96. COACH, FIRST-CLASS. BOSTON & ALBANY RAILROAD.
Turtle-Back Roof.



Fig. 97. COACH. MINNEAPOLIS, SAINT PAUL AND SAULT STE. MARIE RAILWAY.

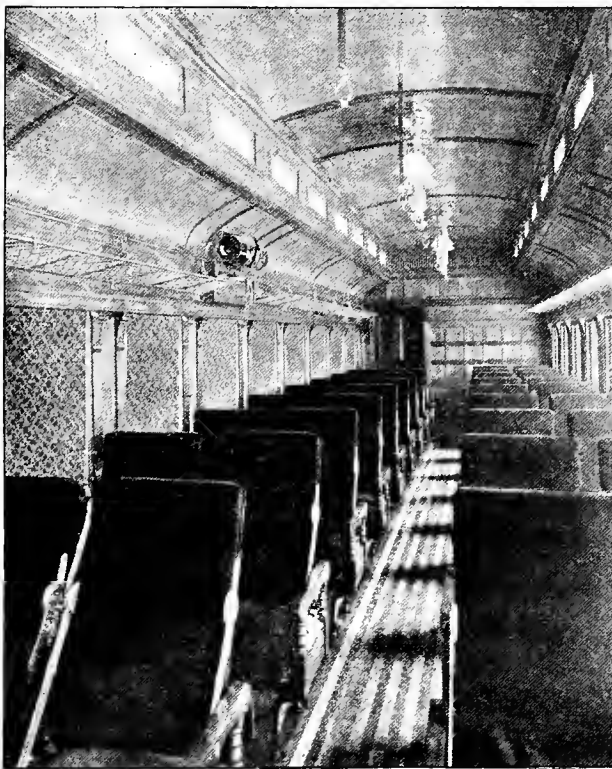

Fig. 98. INTERIOR OF CHAIR CAR.
With Oil Lamps, Continuous Basket Racks, and Reclining Seats.



Fig. 99. INTERIOR OF CAR FOR ELEVATED ROADS.
CHICAGO & SOUTH SIDE RAPID TRANSIT RAILROAD.

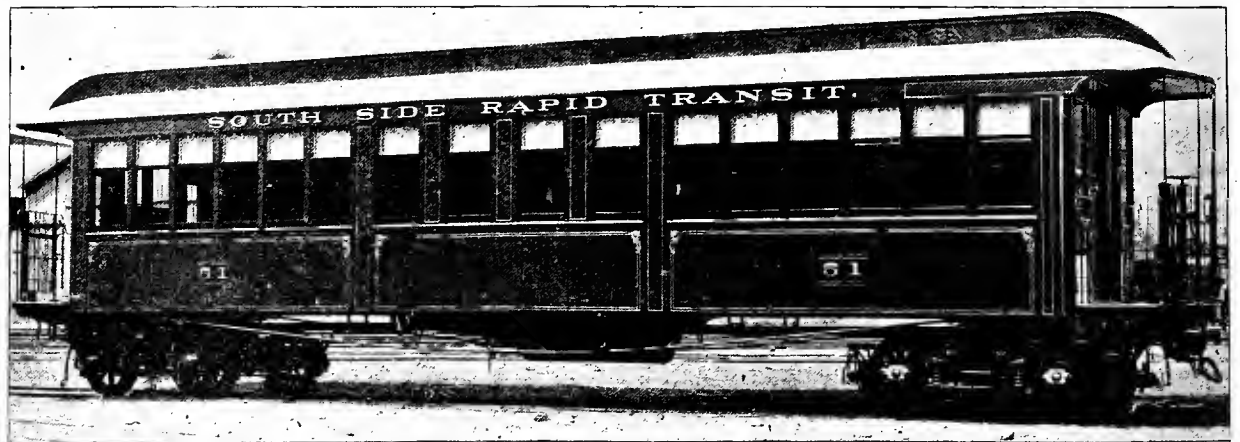

Fig. 100. COACH FOR ELEVATED ROADS. CHICAGO & SOUTH SIDE RAPID TRANSIT RAILROAD.

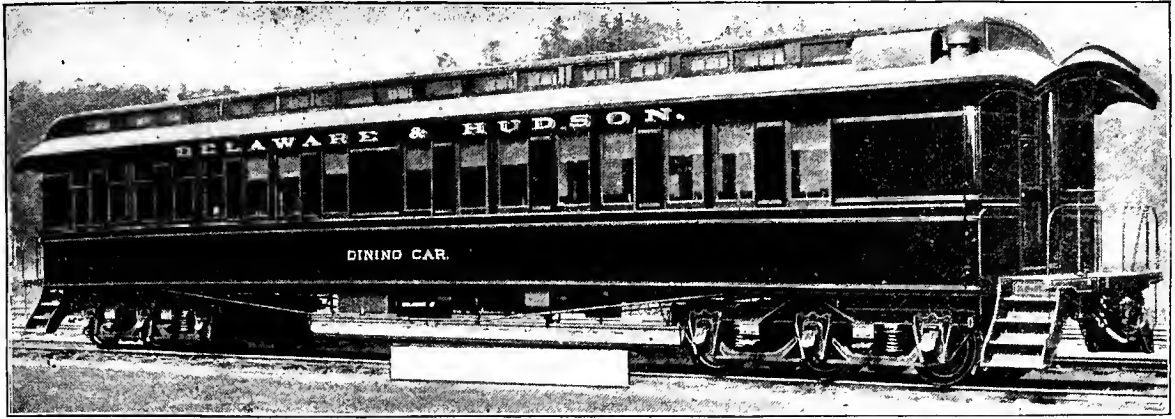

Fig. 101. DINING CAR FOR SUMMER SERVICE. DELAWARE & HUDSON CANAL COMPANY.



Fig. 102. INTERIOR DINING CAR, FOR SUMMER SERVICE.
DELAWARE & HUDSON CANAL COMPANY.

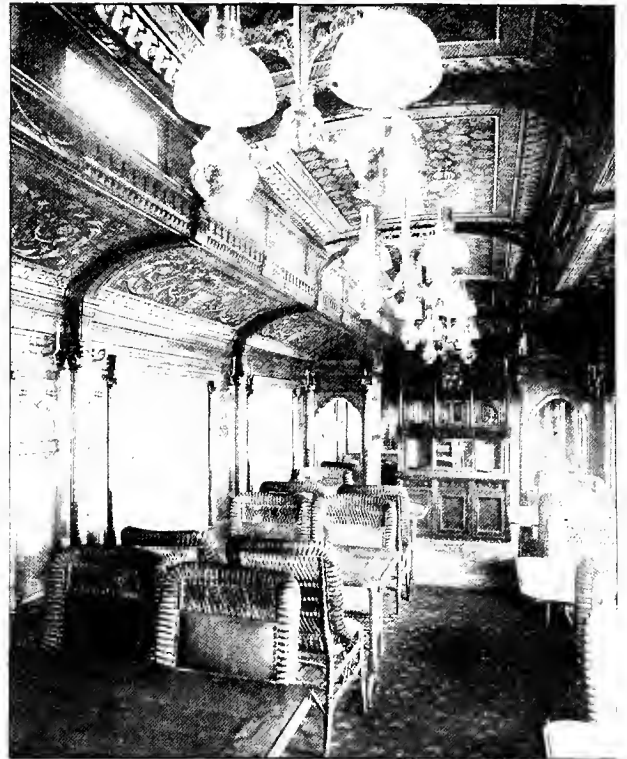
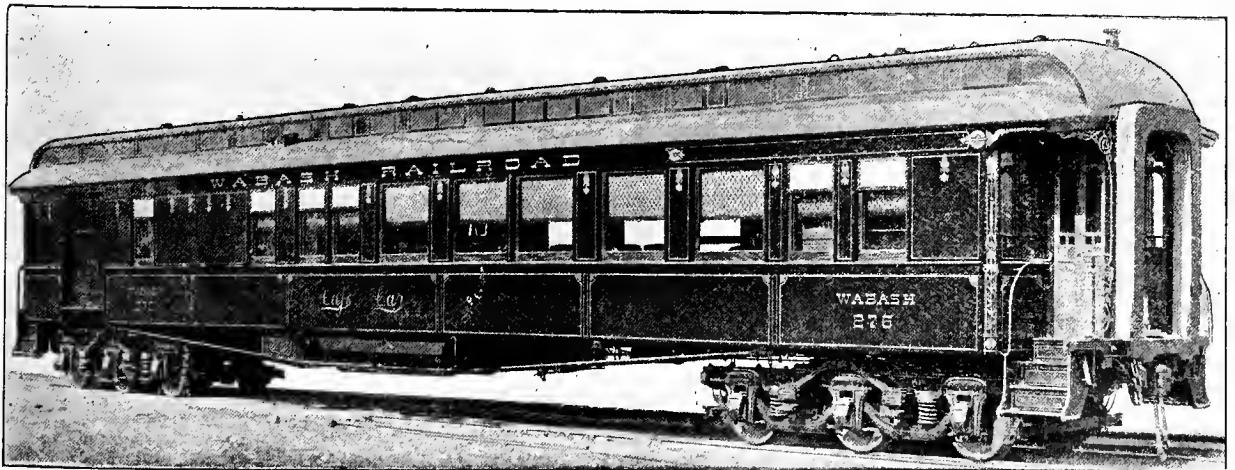

Fig. 103. INTERIOR OF A DINING CAR FOR SUMMER SERVICE.
ATCHISON, TOPEKA & SANTA FE RAILROAD.

Oil Lamps, Portable Tables and Chairs.



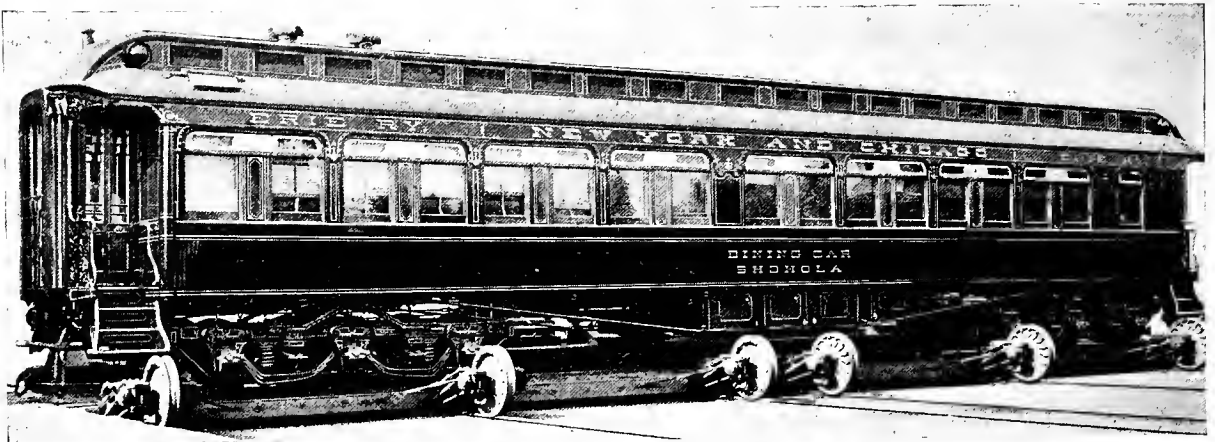

Fig. 105. DINING CAR. NEW YORK, LAKE ERIE & WESTERN RAILROAD.
(Shown on Transfer Table)

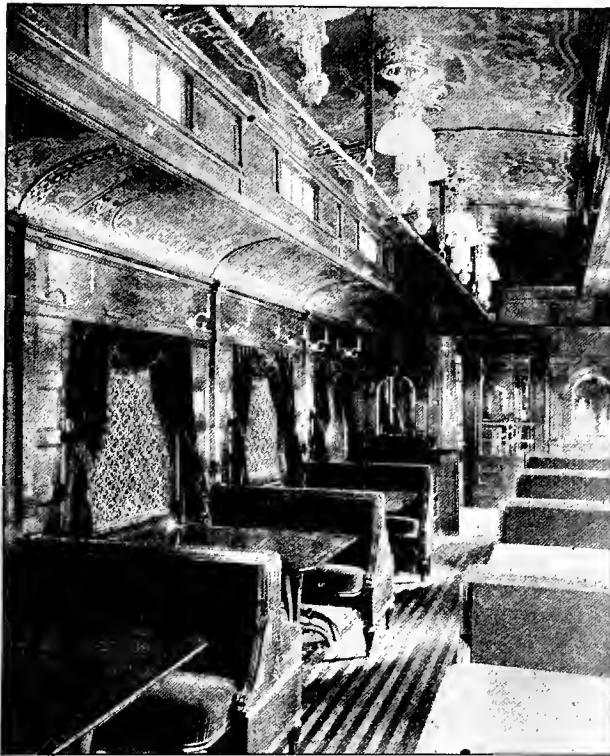

Fig. 106. INTERIOR OF DINING CAR.



Fig. 107. INTERIOR OF DINING CAR, LA RABIDA.

Fig. 107. Exhibited at World's Columbian Exposition, 1893, by Pullman's Palace Car Company.
(Exterior shown in Fig. 110. Plan in Fig. 191.)

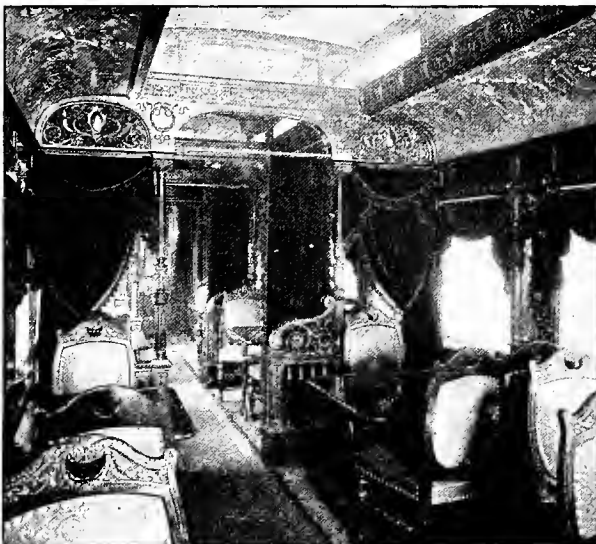

Fig. 108. INTERIOR OF DINING CAR, FERDINAND.
Exhibited at World's Columbian Exposition, 1893, by
Wagner Palace Car Company. (Plan shown in Fig. 179.)

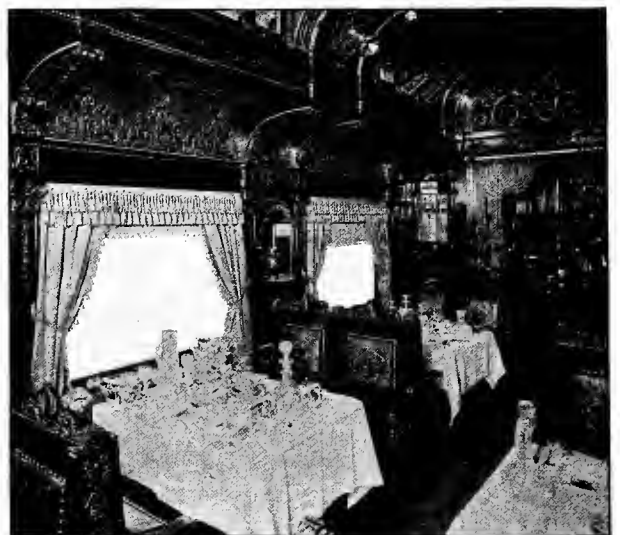

Fig. 109. INTERIOR OF DINING CAR, LA RABIDA.
Exhibited at World's Columbian Exposition, 1893, by
Pullman's Palace Car Company.

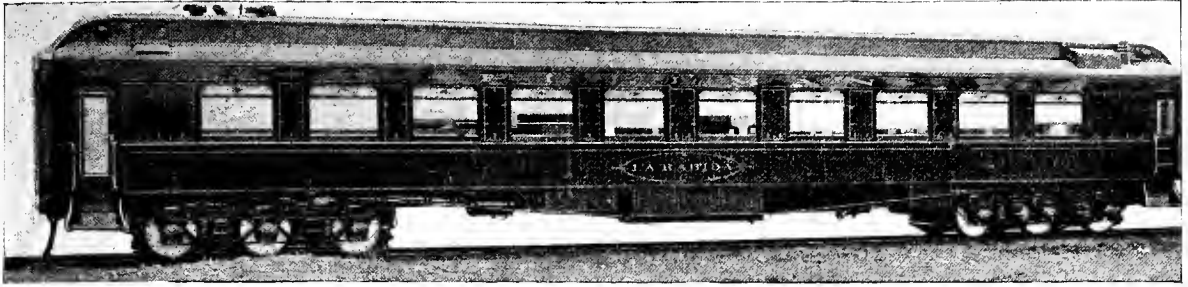

Fig. 110. DINING CAR, LA RABIDA.
Exhibited at World's Columbian Exposition, 1893, by Pullman's Palace Car Company.
(Interiors shown in Figs. 107 and 109. Plan in Fig. 191.)

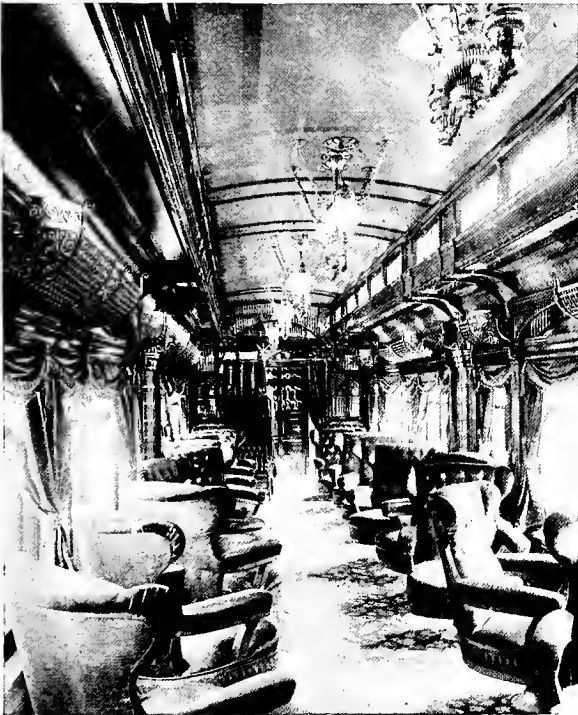

Fig. 111. INTERIOR OF PARLOR CAR FOR GENERAL SERVICE OF
PULLMAN'S PALACE CAR COMPANY.



Fig. 112. INTERIOR OF PARLOR CAR.
BOSTON & ALBANY RAILROAD.
(Turtle-Back Roof.)



Fig. 113. INTERIOR OF PARLOR CAR FOR SUMMER SERVICE.
PENNSYLVANIA RAILROAD'S LIMITED EXPRESS.
(23) (Exterior view is shown in Fig. 113)

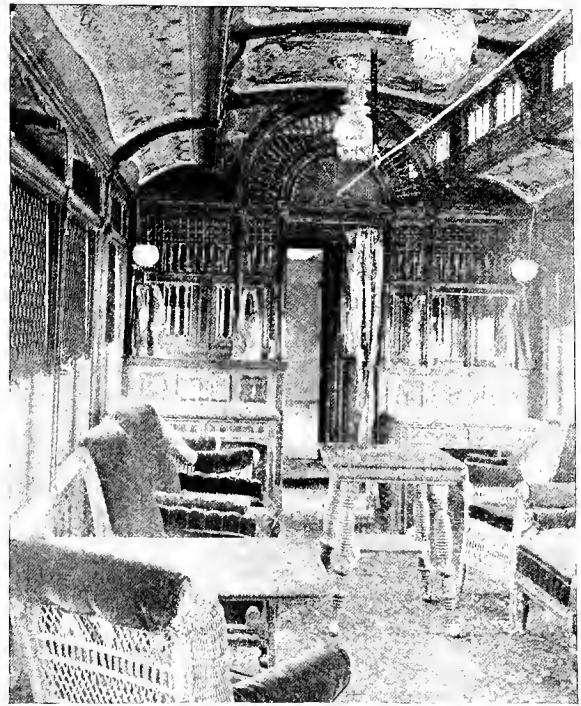

Fig. 114. INTERIOR OF BUFFET PARLOR CAR FOR
SUMMER SERVICE.
Pintsch Lights and Wicker Furniture.

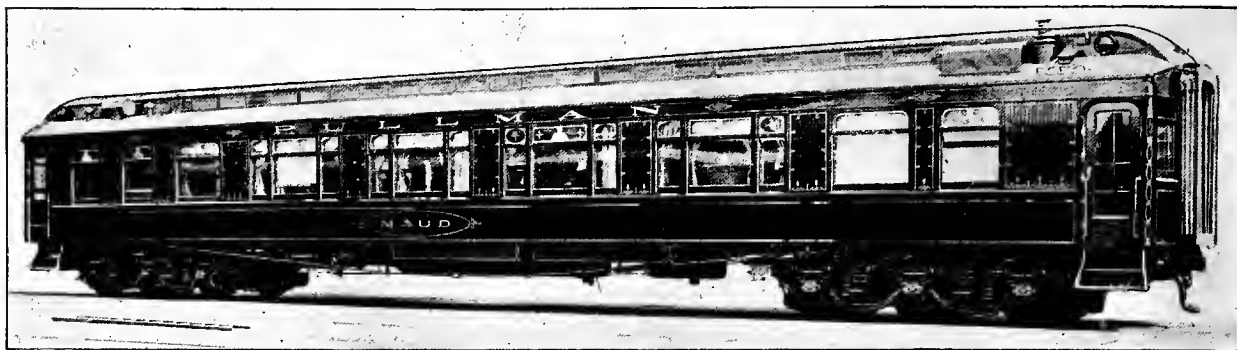

Fig. 115. PARLOR CAR MAUD, FOR GENERAL SERVICE, BUILT BY PULLMAN'S PALACE CAR COMPANY.
(Interior is shown in Fig. 116.)

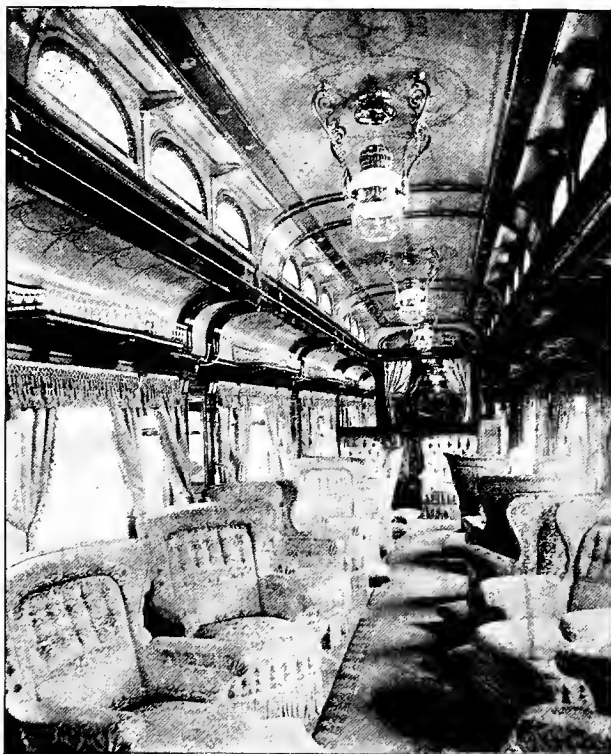

Fig. 116. INTERIOR OF PARLOR CAR MAUD.
Cornice Bracketed to Support Basket Racks, Pintsch Light and Bay Windows.
(Exterior is shown in Fig. 115.)



Fig. 117. INTERIOR OF PARLOR CAR SANTA MARIA.
Exhibited at World's Columbian Exposition by Pullman's Palace Car Company. Bay Windows, Arched Deck Roof, Oval Deck Windows and Electric Light.
(Plan is shown in Fig. 190.)

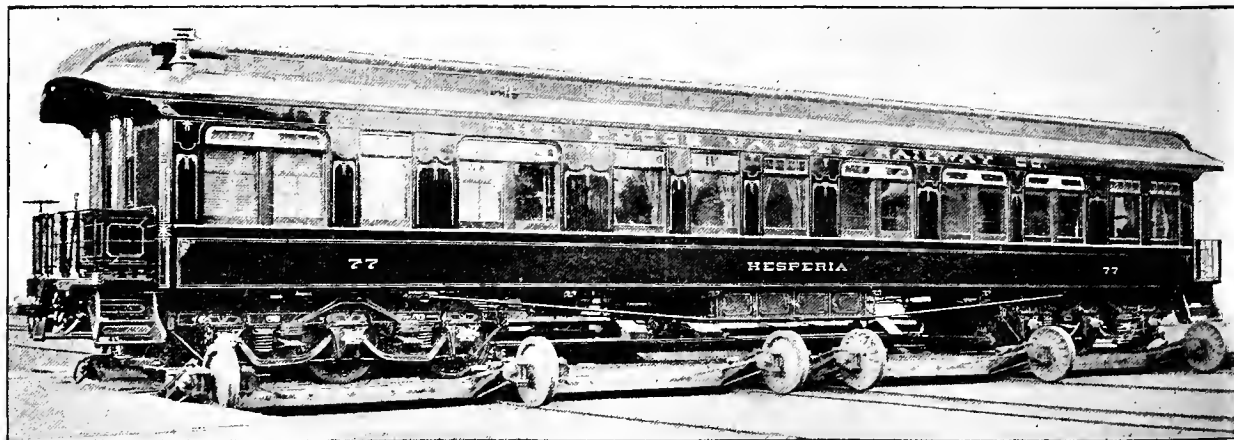

Fig. 118. PRIVATE CAR HESPERIA. THE PECOS VALLEY RAILWAY.
(Shown on Transfer Table.)



Fig. 119. INTERIOR OF PRIVATE CAR, DINING ROOM, BUILT BY PULLMAN'S PALACE CAR COMPANY, 1876. Steam Heat, Oil and Electric Lamps.

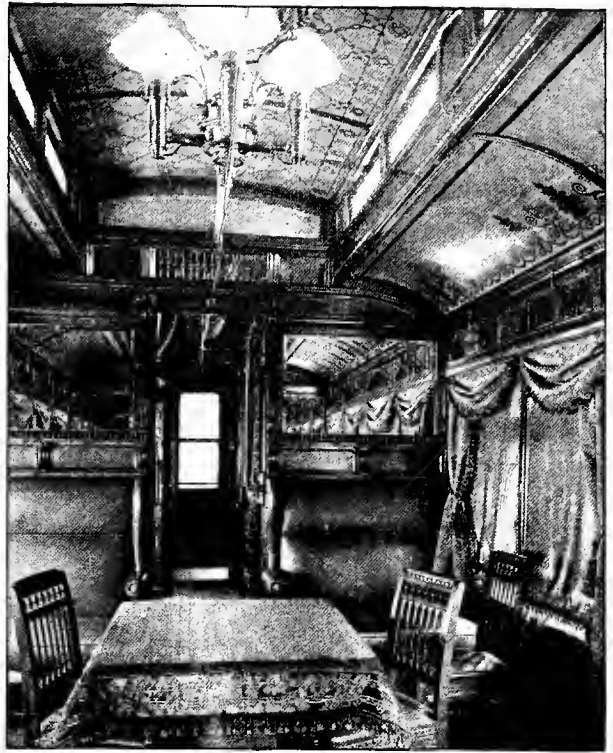

Fig. 120. INTERIOR OF DIRECTORS' CAR, DINING ROOM. NORFOLK & WESTERN RAILROAD, 1890.



Fig. 121. OBSERVATION END OF PARLOR CAR FOR PENNSYLVANIA RAILROAD LIMITED EXPRESS. (Interior shown in Fig. 113.)

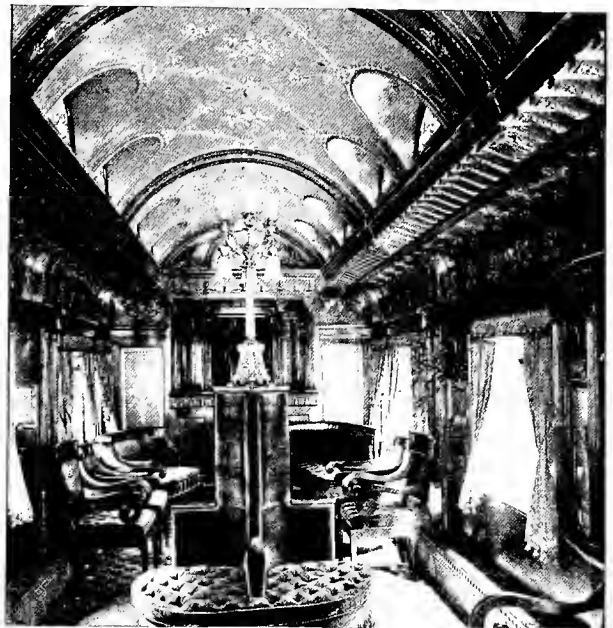

Fig. 122. INTERIOR OF SLEEPING CAR ISABELLA, OBSERVATION ROOM.

Fig. 122 Exhibited at World's Columbian Exposition, 1893, by Pullman's Palace Car Company. Bay Windows, Vaulted Ceiling, Oval Deck Windows and Electric Lights. (Plan shown in Fig. 193.)

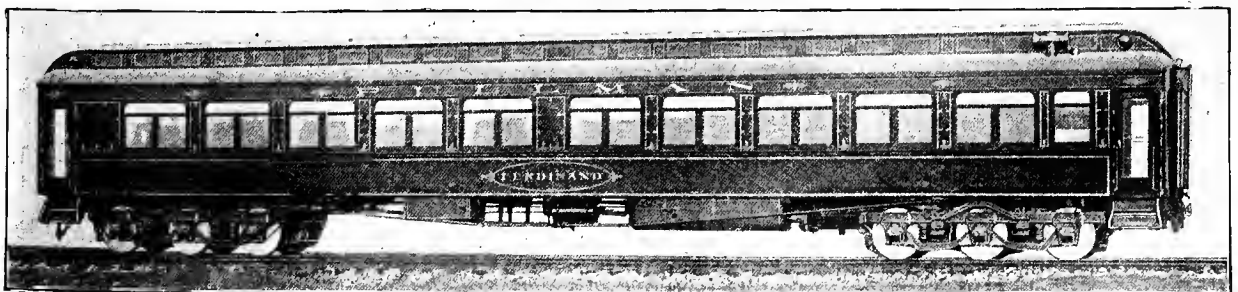

Fig. 123 COMPARTMENT SLEEPING CAR, FERDINAND.

(25) Exhibited at World's Columbian Exposition, 1893, by Pullman's Palace Car Company. (Plan shown in Fig. 187.)



Fig. 124. SLEEPING CAR, PULLMAN'S PALACE CAR COMPANY.
(A type that is being replaced by those shown in Figs. 123 and 129.)



Fig. 125. INTERIOR OF A SLEEPING CAR, BUILT BY
THE BARNEY & SMITH CAR COMPANY.



Fig. 126. INTERIOR OF SLEEPING CAR AMERICA.
Exhibited at World's Columbian Exposition, 1893, by Pullman's
Palace Car Company. Vaulted Ceiling, Oval Deck-Windows,
Disappearing Curtain Rods and Electric Lights.
(Plan is shown in Fig. 186.)



Fig. 127. INTERIOR OF SLEEPING CAR, ISABELLA, STATE ROOM.
Exhibited at World's Columbian Exposition by the Wagner
Palace Car Company. (Plan shown in Fig. 177.)



Fig. 128. INTERIOR OF BUFFET PARLOR CAR, PIZON.
Exhibited at World's Columbian Exposition by the Wagner
Palace Car Company. (Plan shown in Fig. 178.) (26)

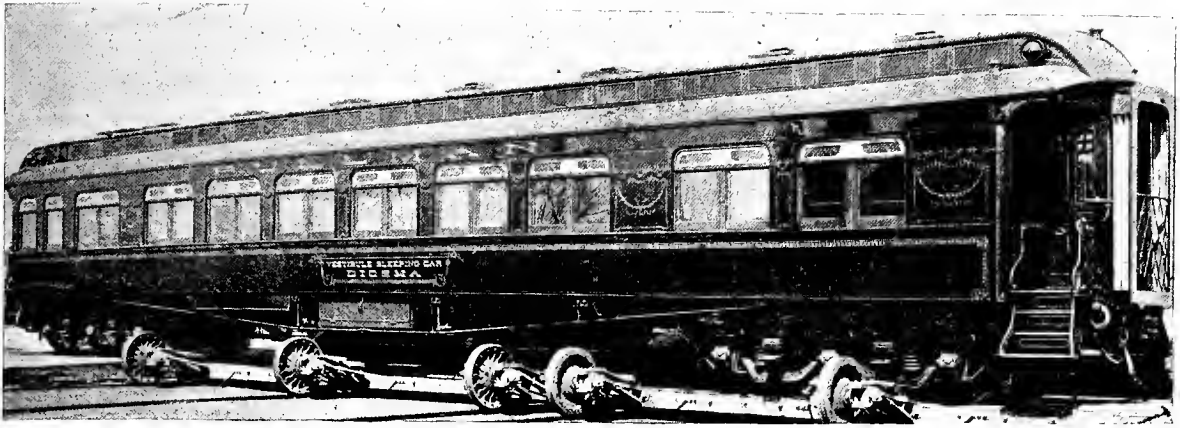

Fig. 129. SLEEPING CAR FOR PULLMAN'S PALACE CAR COMPANY'S SERVICE.
(Shown on Transfer Table)

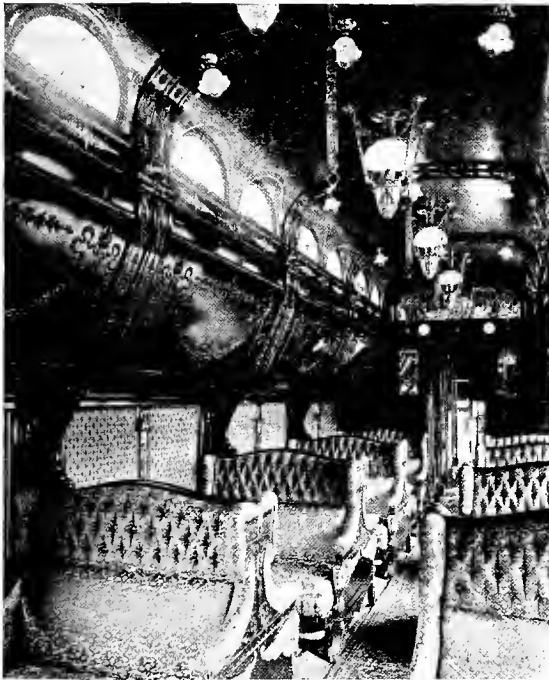

Fig. 130. INTERIOR OF SLEEPING CAR, GLADIOLUS,
PENNSYLVANIA RAILROAD'S LIMITED EXPRESS.

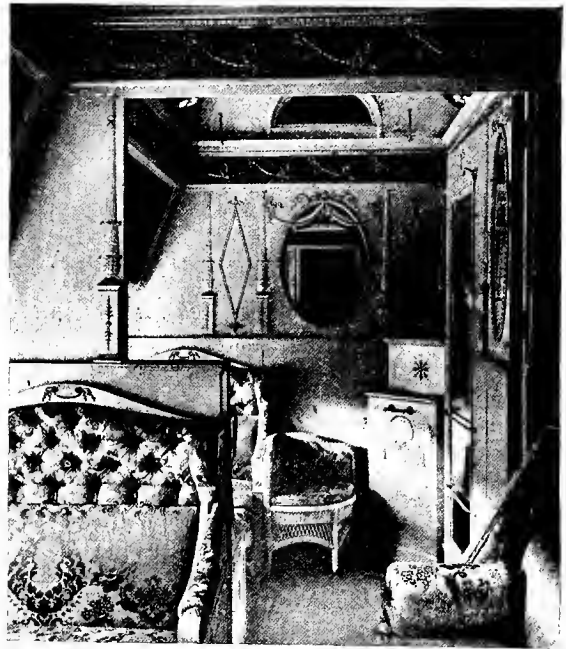

Fig. 131. INTERIOR OF SLEEPING CAR, AMERICA, DRAWING ROOM.
Exhibited at World's Columbian Exposition, 1893, by
Pullman's Palace Car Company.
(Plan is shown in Fig. 186. Another interior is shown in Fig. 126.)



Fig. 132. INTERIOR OF COMBINATION CAR, SMOKING COMPARTMENT.
Exhibited at World's Columbian Exposition by the
Wagner Palace Car Company.
(27) (Plan is shown in Fig. 175.)



Fig. 133. INTERIOR OF COMBINATION CAR, SMOKING COMPARTMENT.
Exhibited at World's Columbian Exposition by
Pullman's Palace Car Company.
(Plan is shown in Fig. 181, exterior in Fig. 131.)

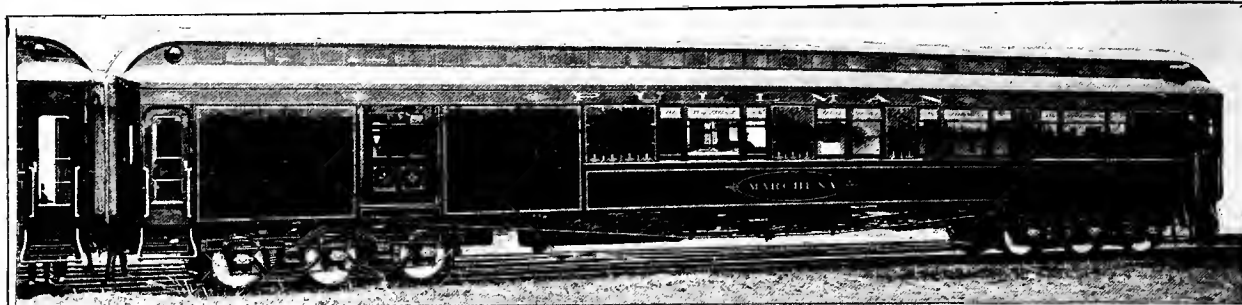

Fig. 134. COMBINATION SMOKING, BARBER SHOP, BATH ROOM AND BAGGAGE CAR. Exhibited at World's Columbian Exposition, 1893, by Pullman's Palace Car Company. (Plan is shown in Fig. 181, interior in Fig. 133.)



Fig. 135. COMBINATION PASSENGER AND BAGGAGE CAR. BALTIMORE & OHIO RAILROAD.



Fig. 136. COMBINATION PASSENGER, BAGGAGE AND MAIL CAR. CHATTANOOGA SOUTHERN RAILWAY.

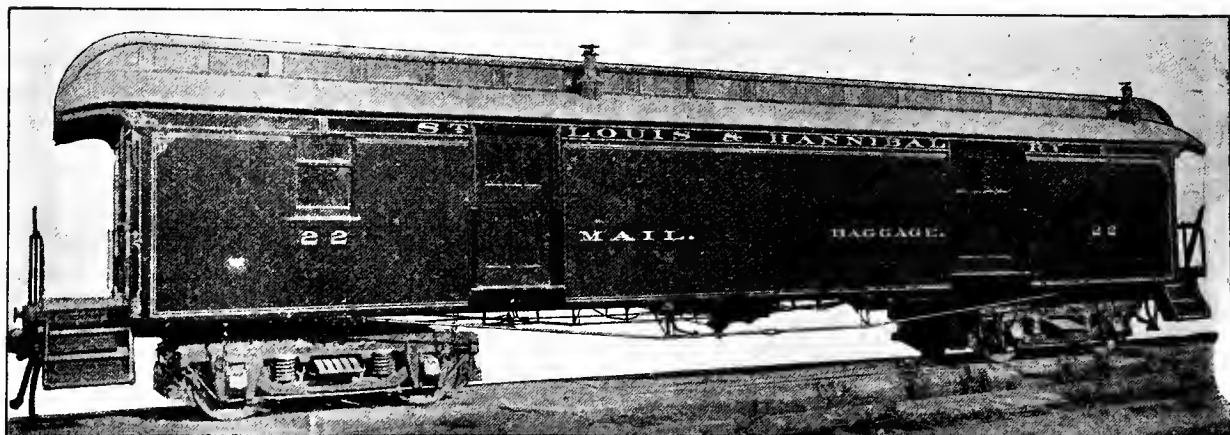

Fig. 137. COMBINATION BAGGAGE AND MAIL CAR. ST. LOUIS & HANNIBAL RAILWAY.

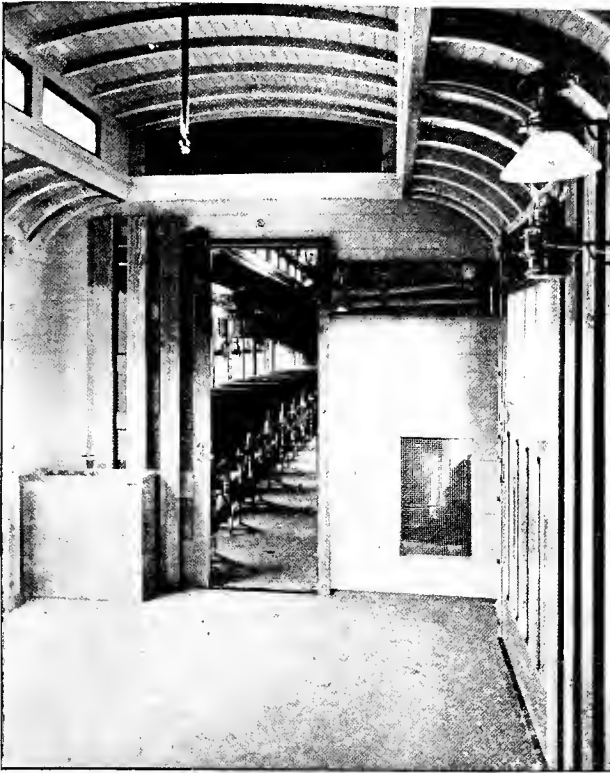

Fig. 138. INTERIOR OF A COMBINATION PASSENGER AND BAGGAGE CAR.

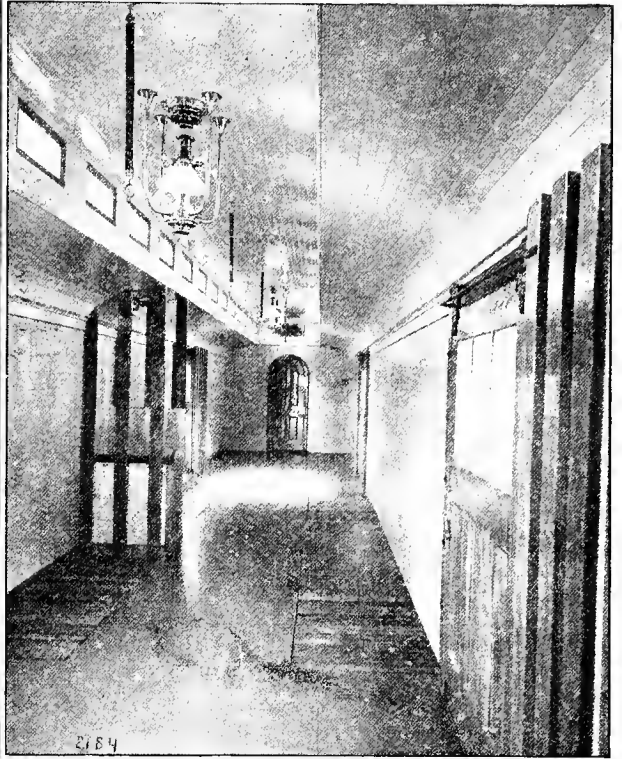

Fig. 139. INTERIOR OF A BAGGAGE AND EXPRESS CAR.

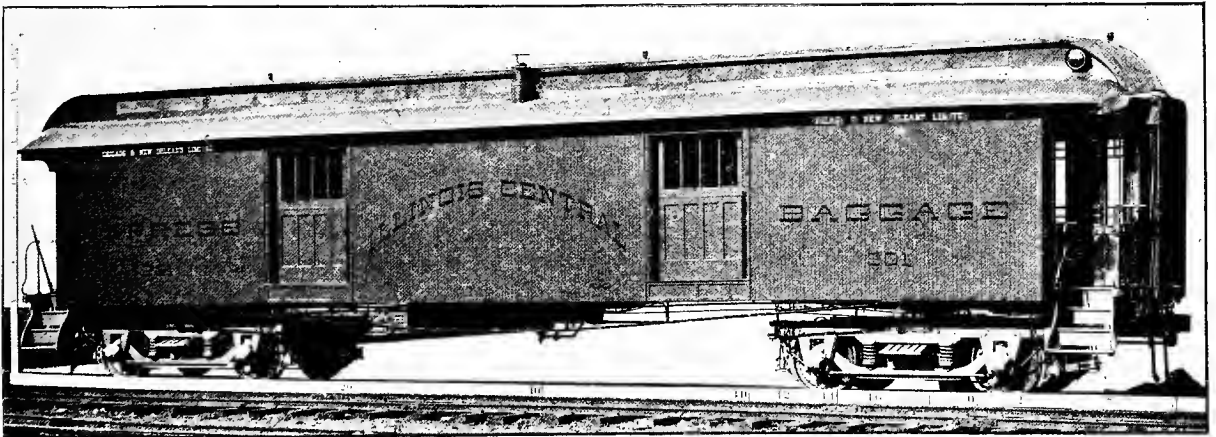

Fig. 140. BAGGAGE AND EXPRESS CAR, ILLINOIS CENTRAL RAILROAD.
Length, 50 ft. 8 ins. Capacity, 40,000 lbs. Weight, 48,400 lbs.



Fig. 141. BAGGAGE CAR, BALTIMORE & OHIO RAILROAD.

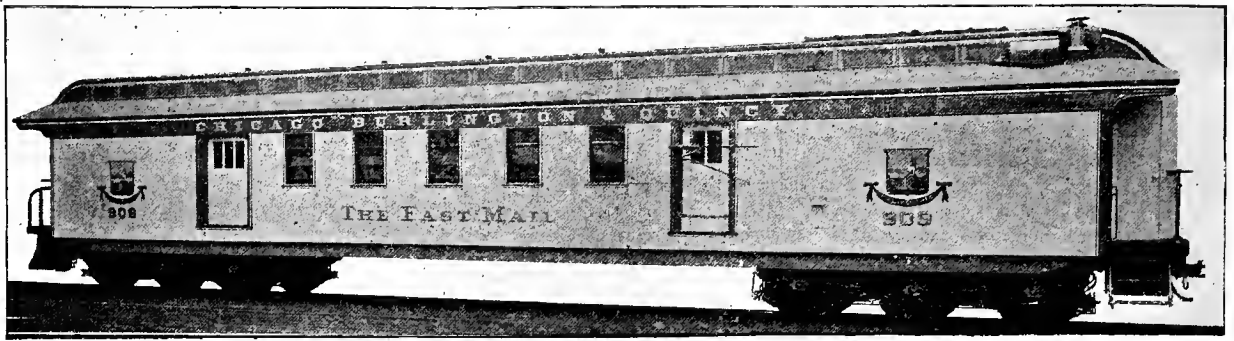

Fig. 142. POSTAL CAR. CHICAGO, BURLINGTON & QUINCY RAILROAD.



Fig. 143. INTERIOR OF POSTAL CAR.

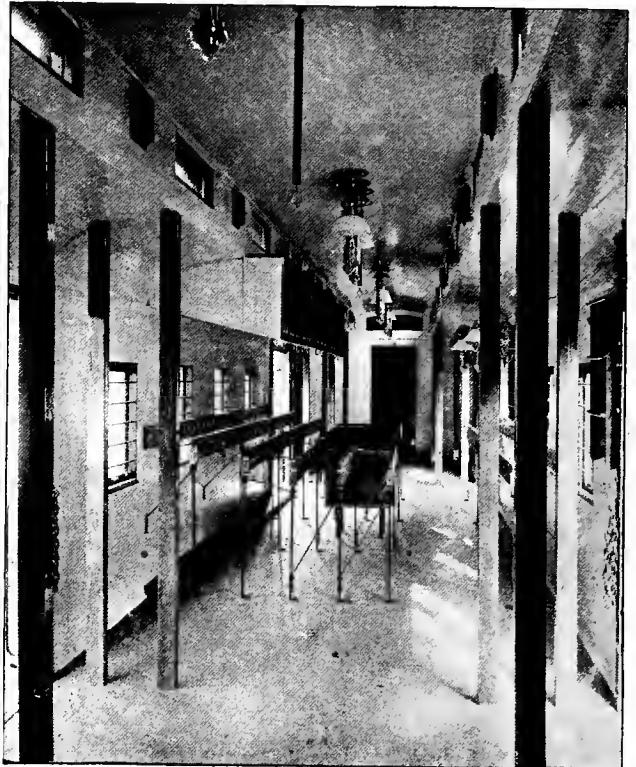

Fig. 144. INTERIOR POSTAL CAR FOR PAPERS.

Fig. 143 Exhibited at World's Columbian Exposition, 1893, by Pullman's Palace Car Company. Harrison Bag Racks and Table. (Plan is shown in Figs. 182 and 183.) Letter Case End in Background.

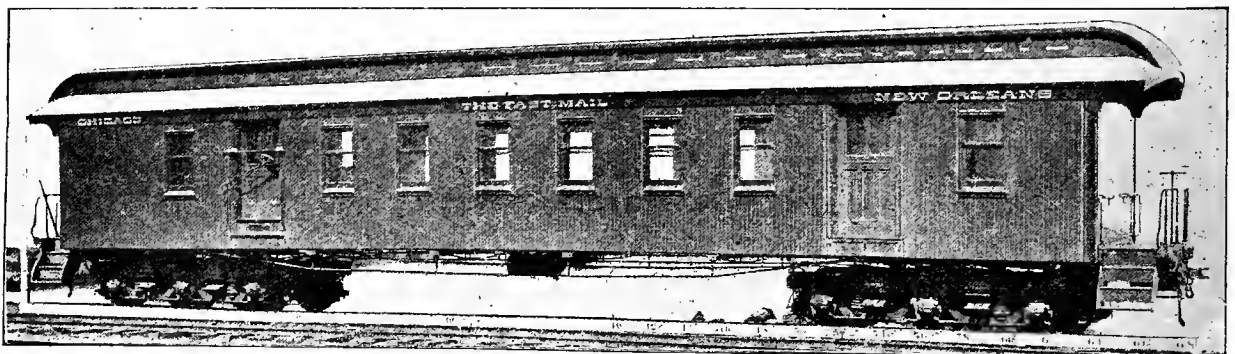

Fig. 145. POSTAL CAR, WITH ONE END DOOR. ILLINOIS CENTRAL RAILROAD.
Length, 60 ft. 9 ins. Capacity, 40,000 lbs. Weight, 72,100 lbs.

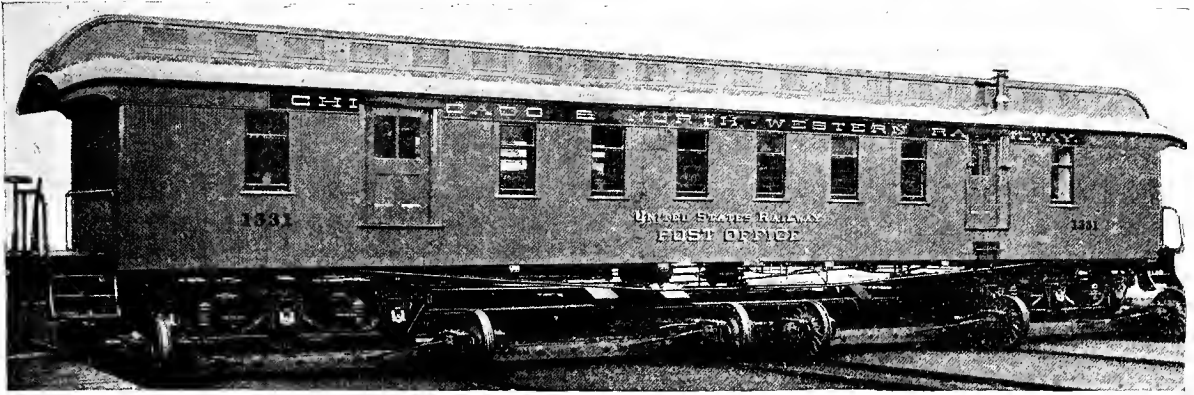

Fig. 146. POSTAL CAR, CHICAGO & NORTHWESTERN RAILWAY.
(Shown on Transfer Table.)



Fig. 147. INTERIOR POSTAL CAR, SHOWING LETTER CASE, END, LAMPS AND SKYLIGHT.

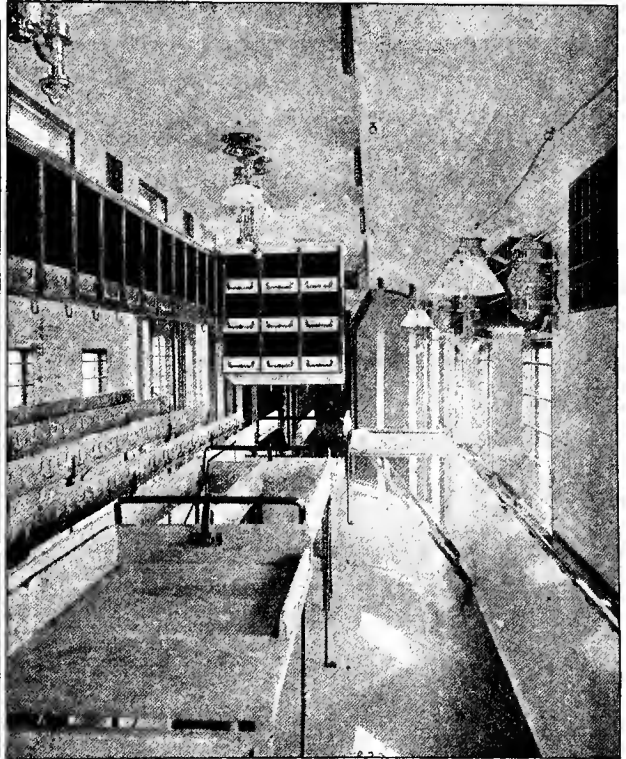

Fig. 148. INTERIOR POSTAL CAR, SHOWING BAG RACKS, REVERSIBLE TABLES AND PAPER BOXES.

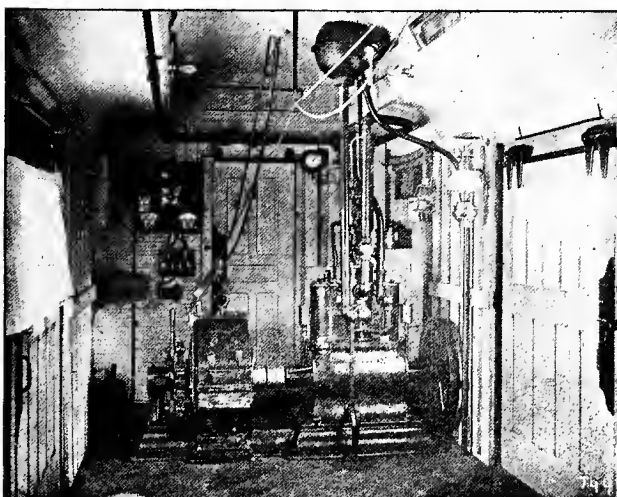

Fig. 149. ELECTRIC LIGHT PLANT.
CHICAGO, MILWAUKEE & ST. PAUL RAILWAY.
(Placed in the end of Baggage Cars.)

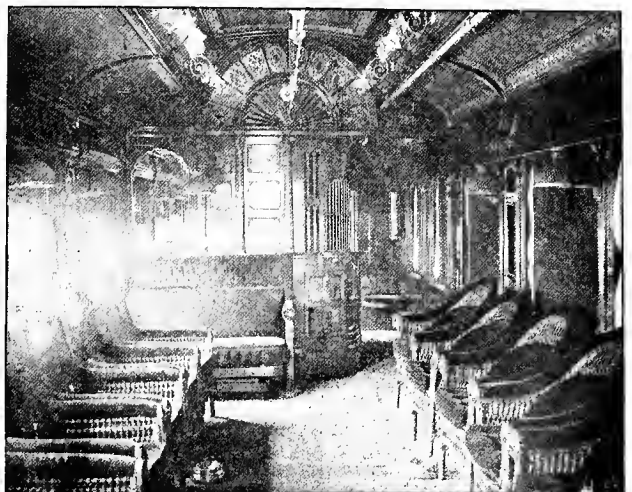

Fig. 150. INTERIOR PARLOR CAR.
CHICAGO, MILWAUKEE & ST. PAUL RAILWAY.
(Showing Arrangement of Lamps for Electric Lighting.)

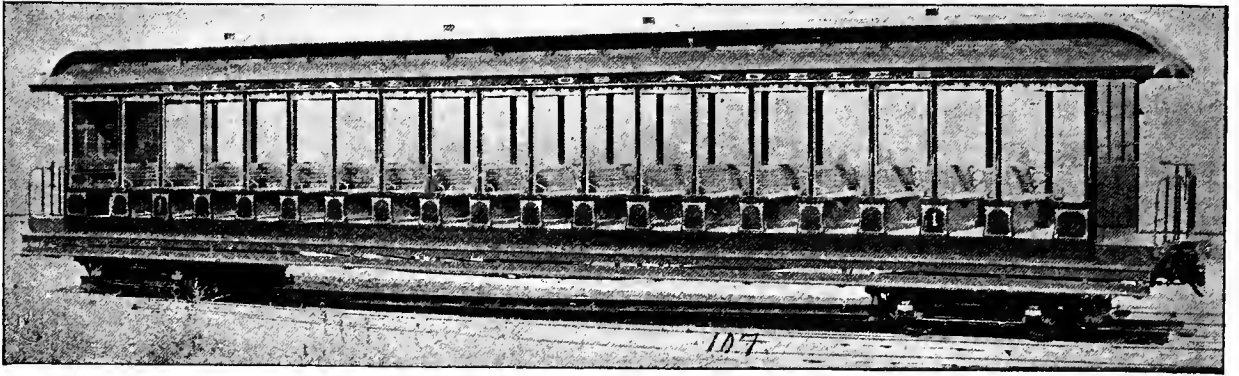

Fig. 151. OPEN EXCURSION CAR FOR SUBURBAN ROADS. SALT LAKE & LOS ANGELES RAILROAD.



Fig. 152. INTERIOR OF TOURIST OR EMIGRANT SLEEPING CAR. SOUTHERN PACIFIC COMPANY. (Details shown in Figs. 505-511)

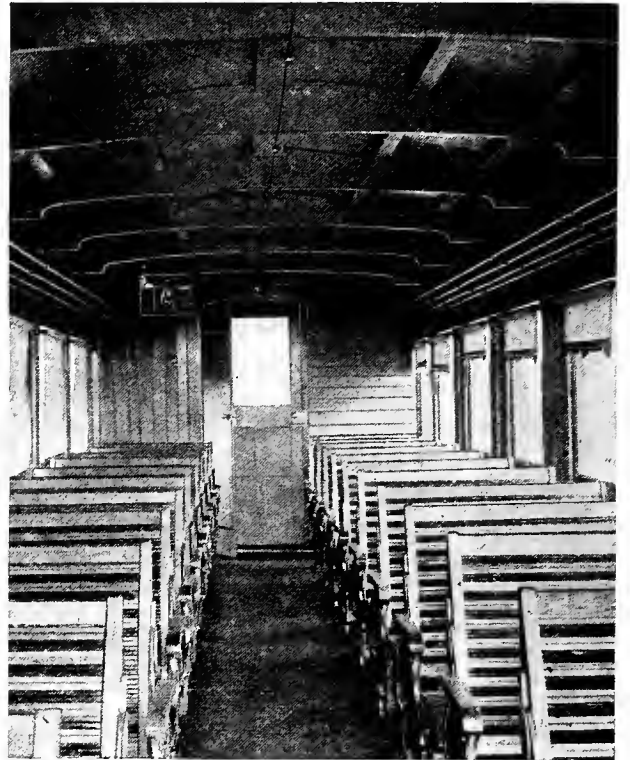

FIG. 153. INTERIOR OF SPECIAL TOURIST CAR FOR EXCURSIONISTS AND TROOPS. PENNSYLVANIA COMPANY.

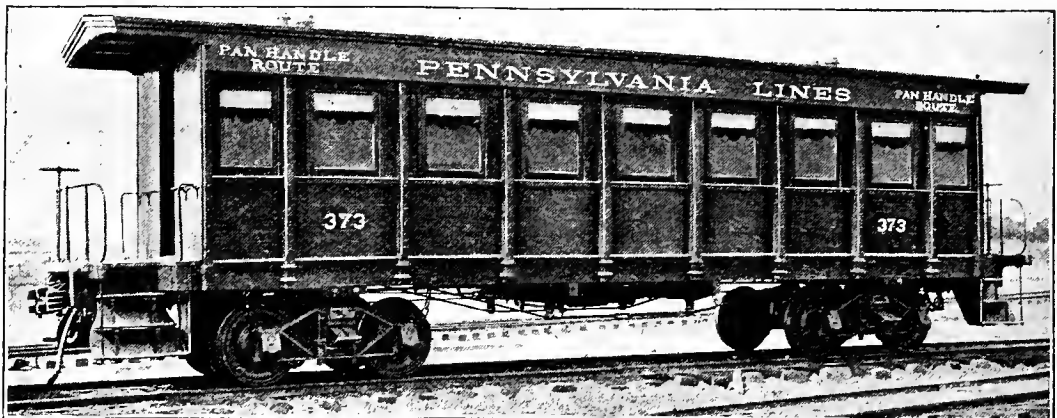

Fig. 154. SPECIAL TOURIST CAR FOR EXCURSIONISTS AND TROOPS. PENNSYLVANIA COMPANY. Designed for World's Fair Service.

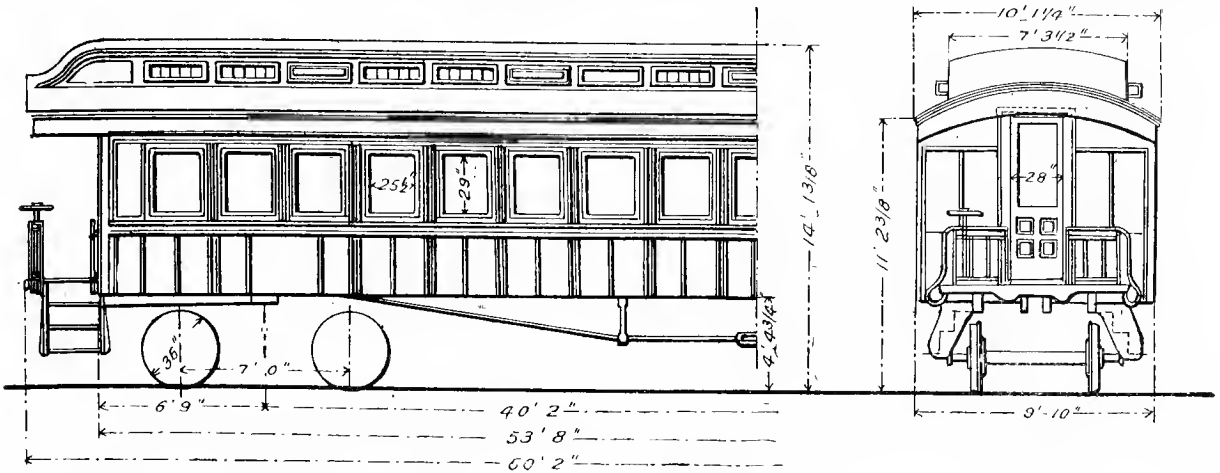

Fig. 155. PASSENGER COACH. PENNSYLVANIA RAILROAD.
Seating capacity, 64 persons. Weight, 65,600 lbs. (Details are shown in Figs. 435-443.)

Fig. 156.

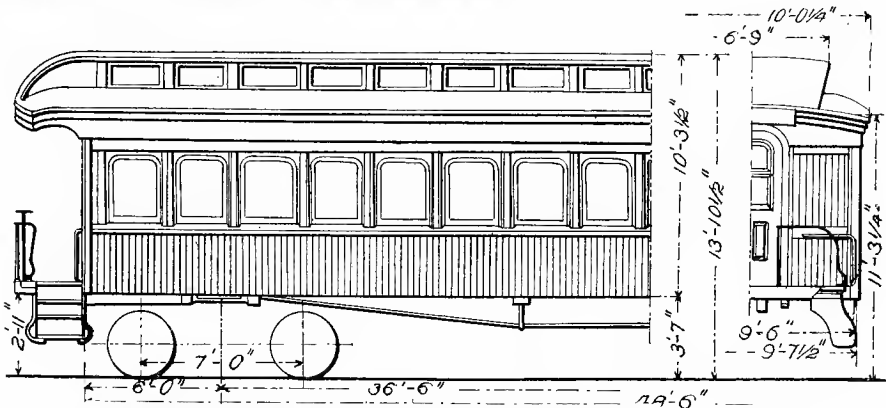

Fig. 157. PASSENGER COACH. BALTIMORE & OHIO RAILROAD.
Length, 43 ft. 6 ins. Capacity, 56 persons. Weight, 53,300 lbs.
(Details are shown in Figs. 153-160.)

Fig. 158.

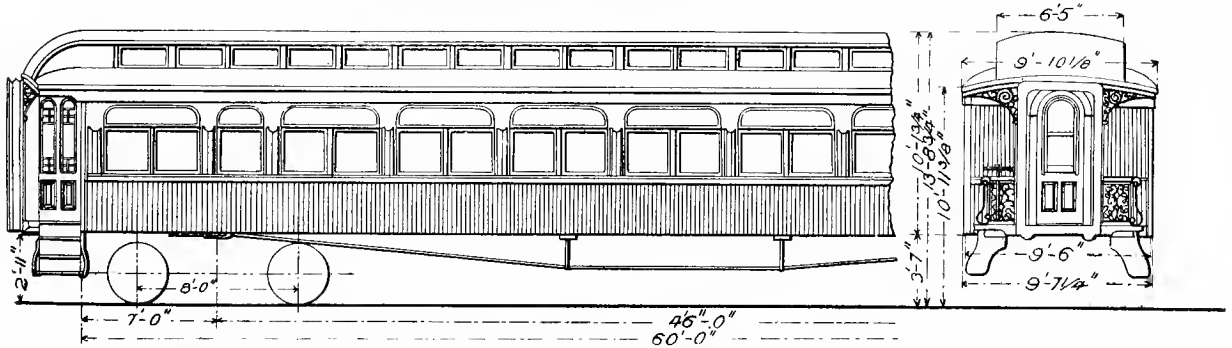

Fig. 159. PASSENGER COACH. BALTIMORE & OHIO RAILROAD.
Length, 60 ft. Capacity, 67 persons. Weight, 70,600 lbs. Lavatories and Smoking Room.

Fig. 160.

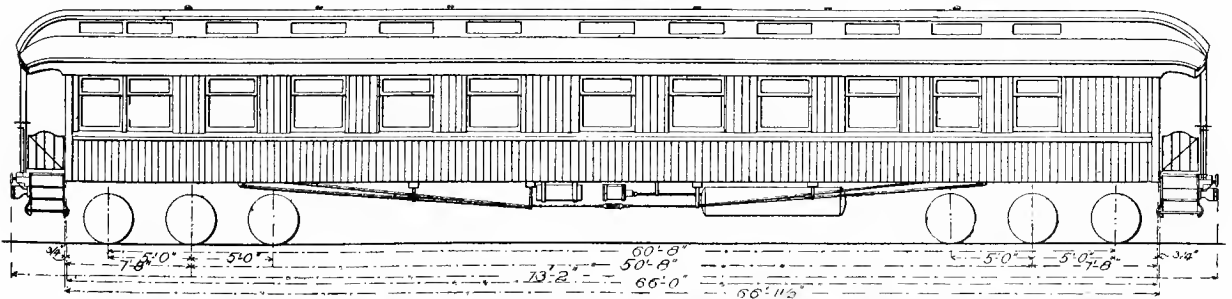

Fig. 161. CLUB CAR NETHERWOODS. CENTRAL RAILROAD OF NEW JERSEY.

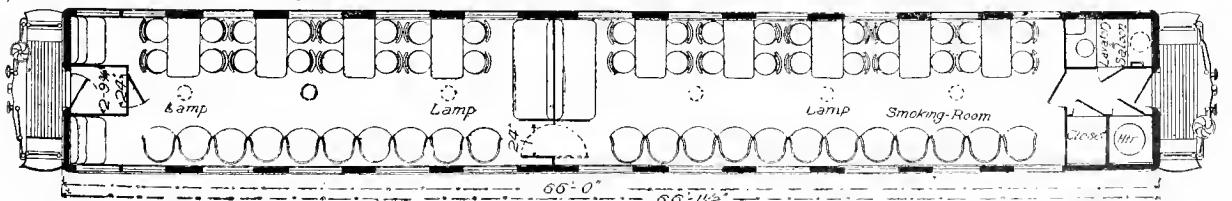

Fig. 162. CLUB CAR NETHERWOODS. CENTRAL RAILROAD OF NEW JERSEY.

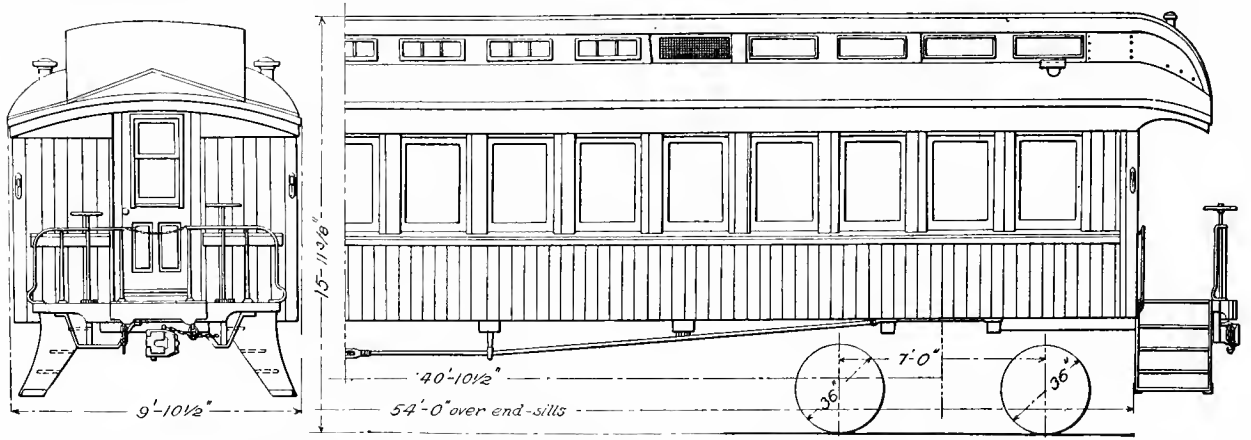

Fig. 163-164. PASSENGER COACH. NEW YORK CENTRAL & HUDSON RIVER RAILROAD.

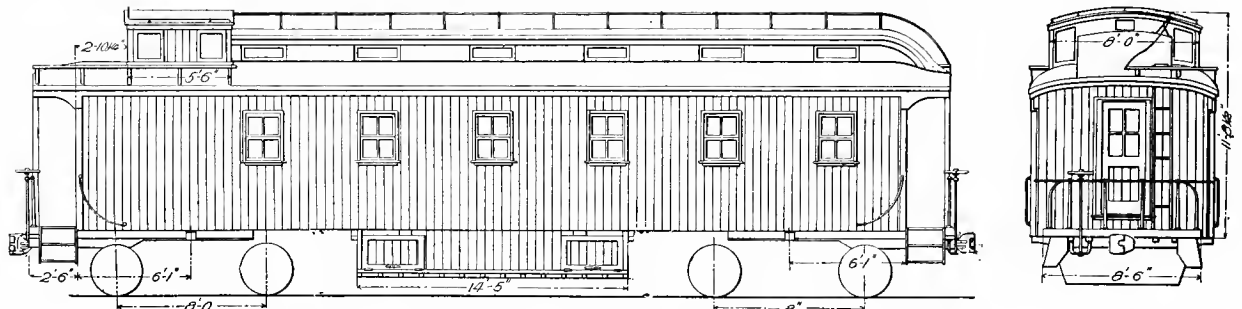

Fig. 165-166. BOARDING CAR. CHICAGO, BURLINGTON & QUINCY RAILROAD.

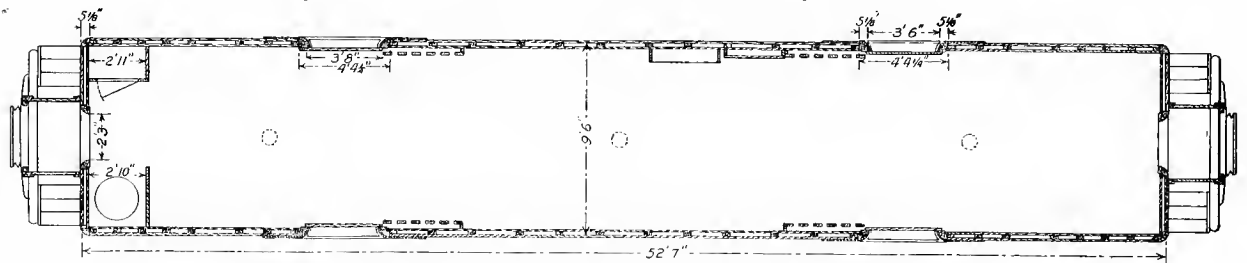
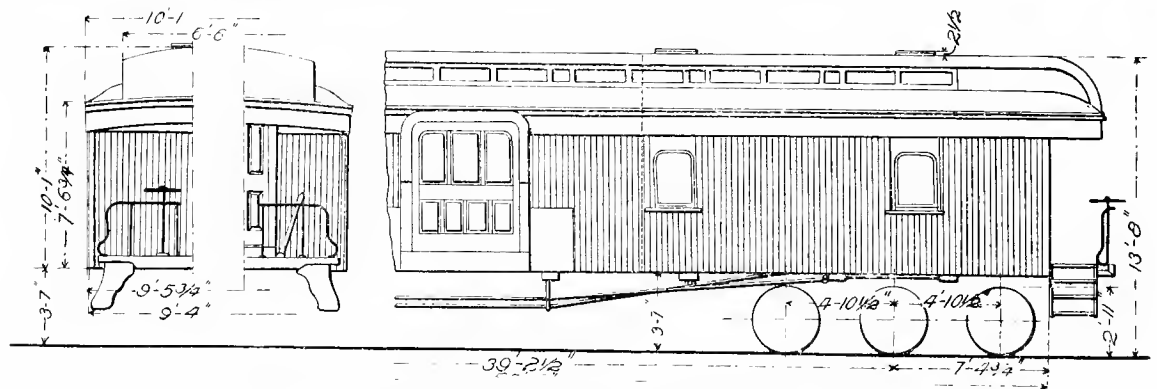
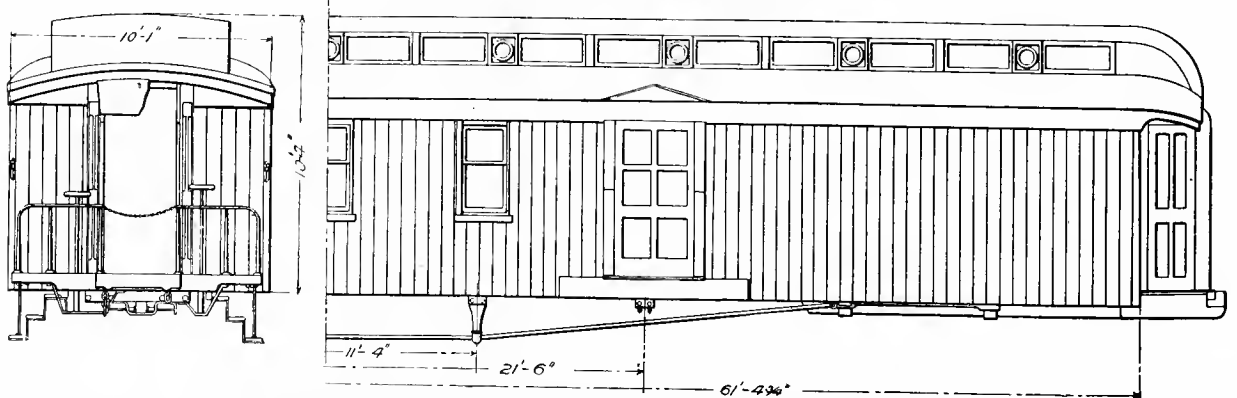

Fig. 167. PLAN OF BAGGAGE CAR BUILT BY PULLMAN'S PALACE CAR COMPANY.



Figs. 168-170. REFRIGERATOR EXPRESS CAR. BALTIMORE & OHIO RAILROAD.

Inside length, 53 ft. 2 ins. Weight, 63,300 lbs.
(Interior arrangement is shown in Figs. 596-597.)



Figs. 171-172. POSTAL CAR. NEW YORK CENTRAL & HUDSON RIVER RAILROAD.

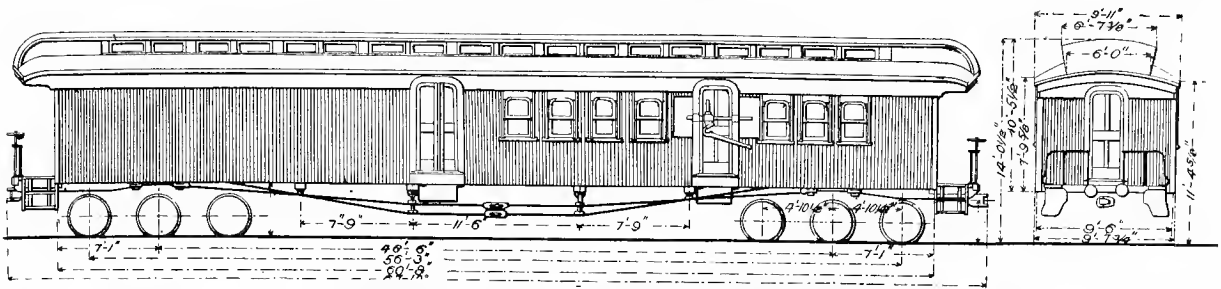

Figs. 173-174. POSTAL CAR, BALTIMORE & OHIO RAILROAD.
Length, 60 ft. Weight, 65,600 lbs.

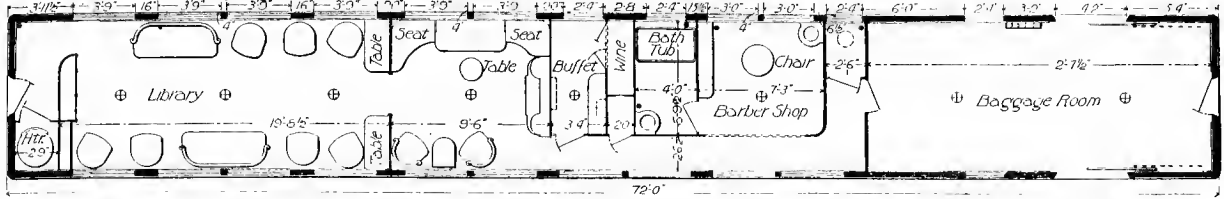

Fig. 175. SECTIONAL PLAN OF COMBINATION BAGGAGE, BARBER SHOP, BATH ROOM AND LIBRARY CAR, COLUMBUS.
(Interior view is shown in Fig. 132.)

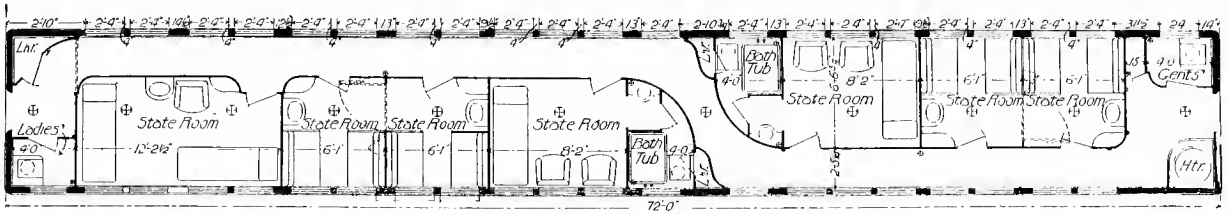

Fig. 176. SECTIONAL PLAN OF COMPARTMENT SLEEPING CAR, SAN SALVADOR.

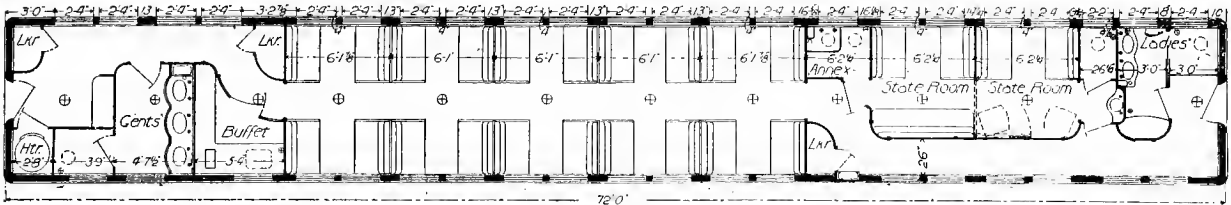

Fig. 177. SECTIONAL PLAN OF SLEEPING CAR, ISABELLA. (Interior view is shown in Fig. 127.)

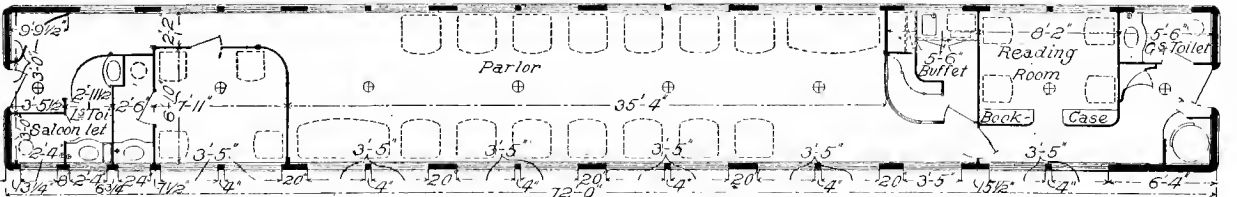

Fig. 178. SECTIONAL PLAN OF BUFFET CAR, PIZON. (Interior view is shown in Fig. 128.)

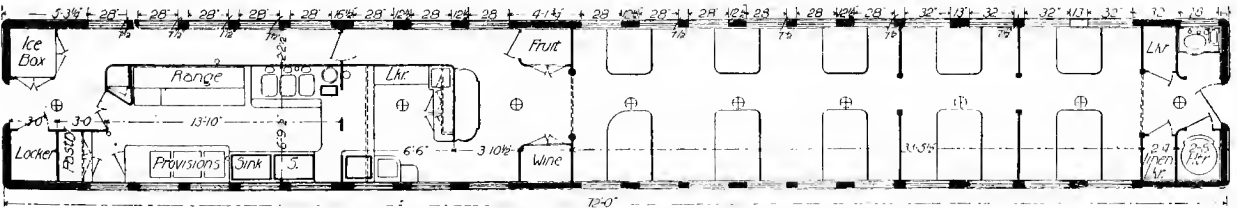

Fig. 179. SECTIONAL PLAN OF DINING CAR, FERDINAND.
(Interior view is shown in Fig. 108.)

Figs. 175-179 are Cars Exhibited at the World's Columbian Exposition, 1893, by the Wagner Palace Car Company.

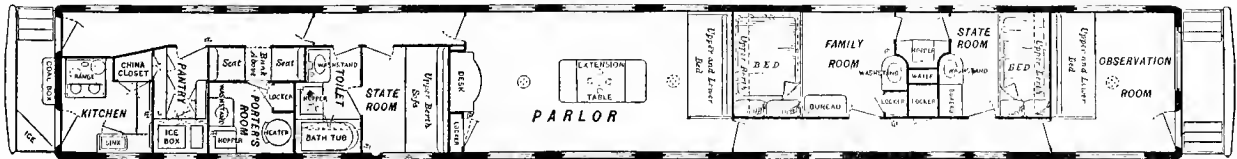

Fig. 180. SECTIONAL PLAN OF PRIVATE CAR, ELLSMERE, BUILT BY THE WAGNER PALACE CAR COMPANY.

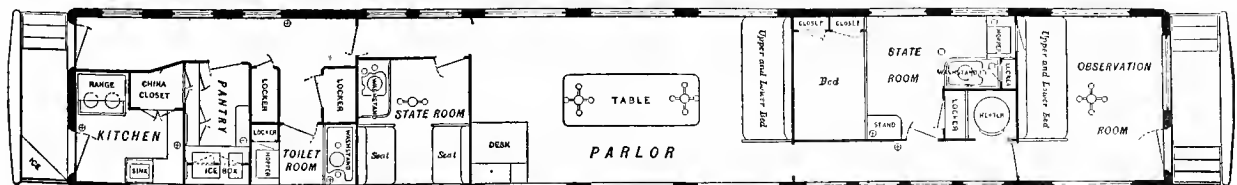

Fig. 181. SECTIONAL PLAN OF PRIVATE CAR, GRASSMERE, BUILT BY THE WAGNER PALACE CAR COMPANY.

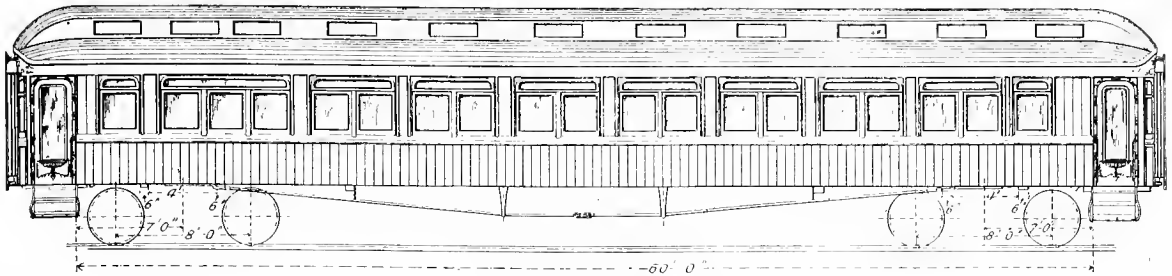

Fig. 188. Side Elevation.
FIRST CLASS COACH.

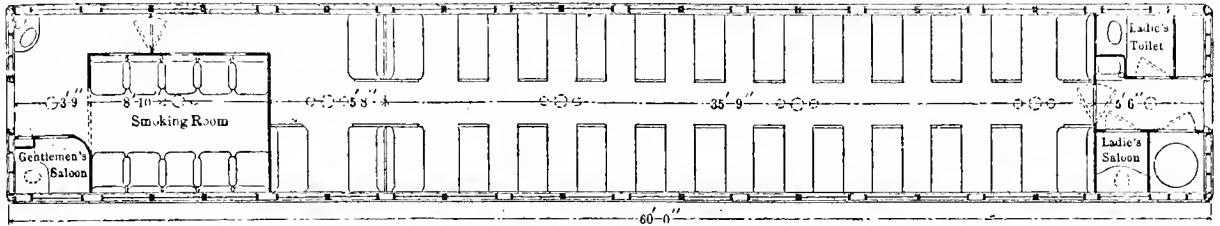

Fig. 189. Sectional Plan.
FIRST CLASS COACH.

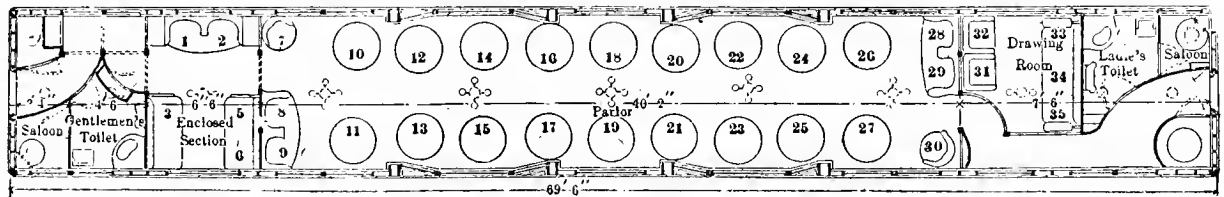

Fig. 190. Sectional Plan.
PARLOR CAR, SANTA MARIA.
(Interior view is shown in Fig. 117.)

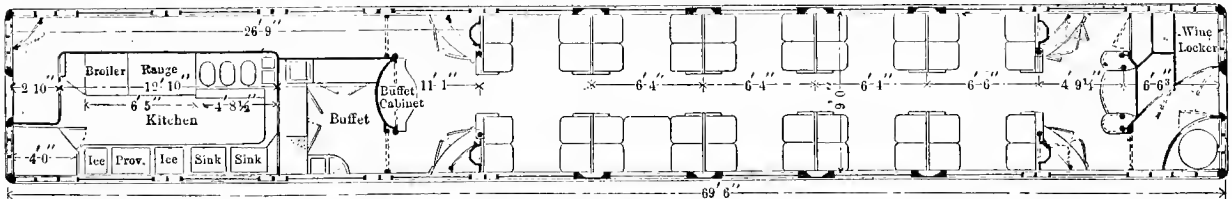

Fig. 191. Sectional Plan.
DINING CAR, LA RABIDA.
(Exterior and interior views are shown in Figs. 107, 109 and 110.)

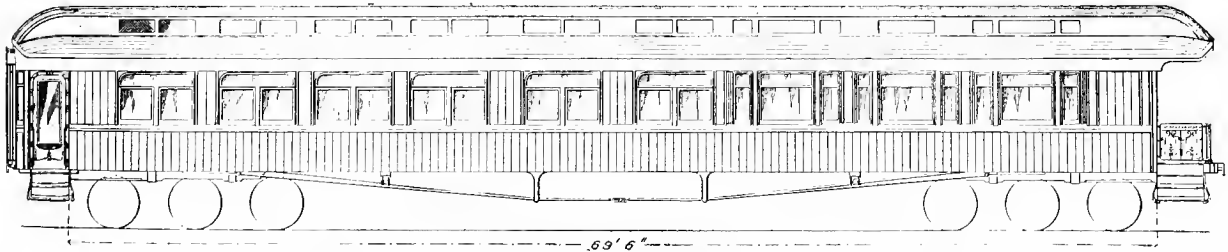

Fig. 192. Side Elevation.
COMBINATION LIBRARY, SLEEPING AND OBSERVATION CAR, ISABELLA.
(Interior view is shown in Fig. 122.)

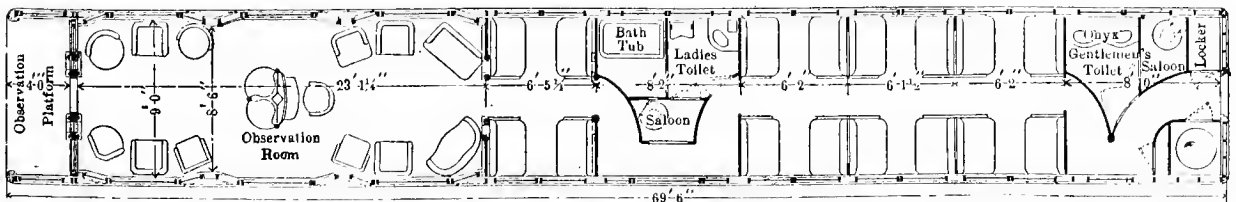

Fig. 193. Sectional Plan.
COMBINATION LIBRARY, SLEEPING AND OBSERVATION CAR, ISABELLA.
(Interior is shown in Fig. 122.)

Framing of all these cars is shown in Figs. 512-522.

CARS EXHIBITED AT THE WORLD'S COLUMBIAN EXPOSITION, 1893, BY PULLMAN'S PALACE CAR COMPANY.

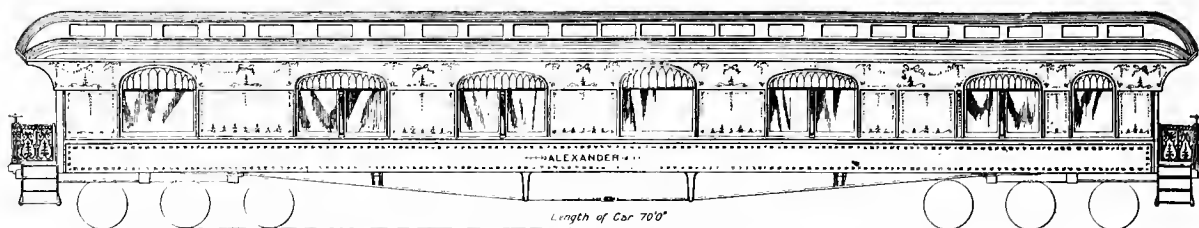

Fig. 194. Side Elevation.
PRIVATE CAR, ALEXANDER, BUILT BY PULLMAN'S PALACE CAR COMPANY.

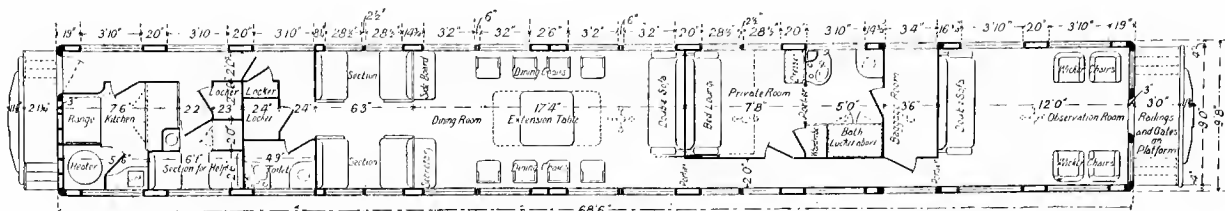

Fig. 195. Sectional Plan.
PRIVATE CAR, BUILT BY PULLMAN'S PALACE CAR COMPANY.

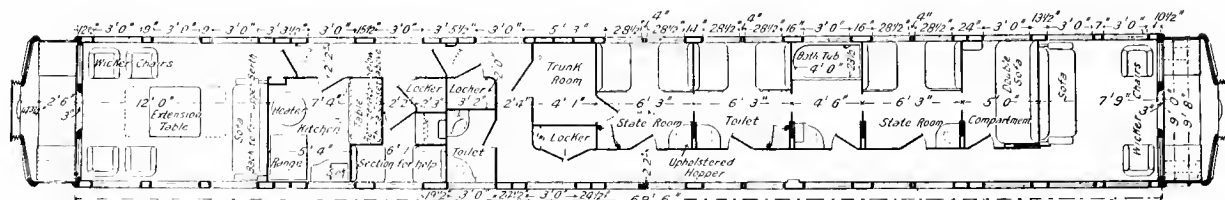

Fig. 196. Sectional Plan.
PRIVATE CAR, BUILT BY PULLMAN'S PALACE CAR COMPANY.

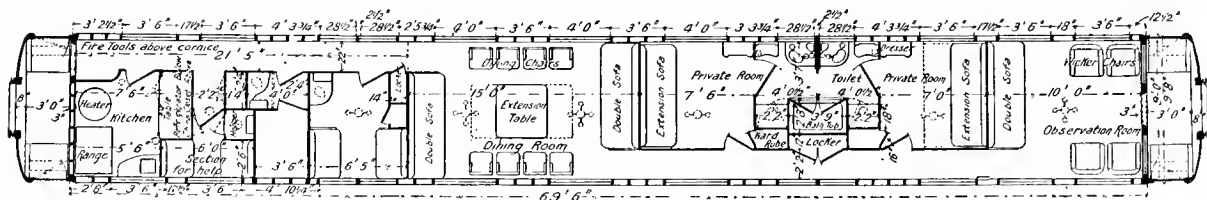

Fig. 197. Sectional Plan.
PRIVATE CAR, BUILT BY PULLMAN'S PALACE CAR COMPANY.

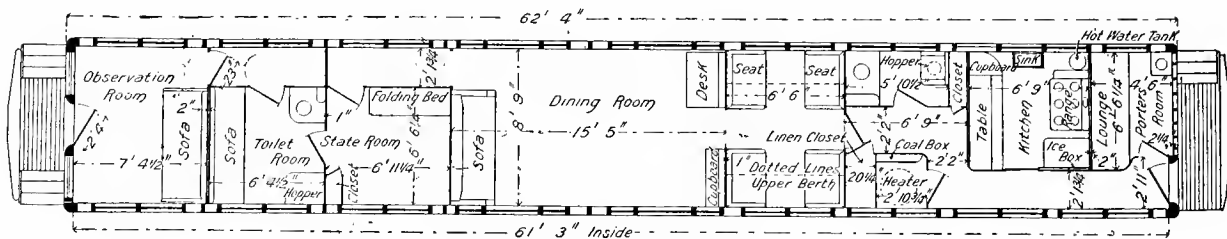

Fig. 198. Sectional Plan.
BUSINESS CAR, NEW YORK, LAKE ERIE & WESTERN RAILROAD.

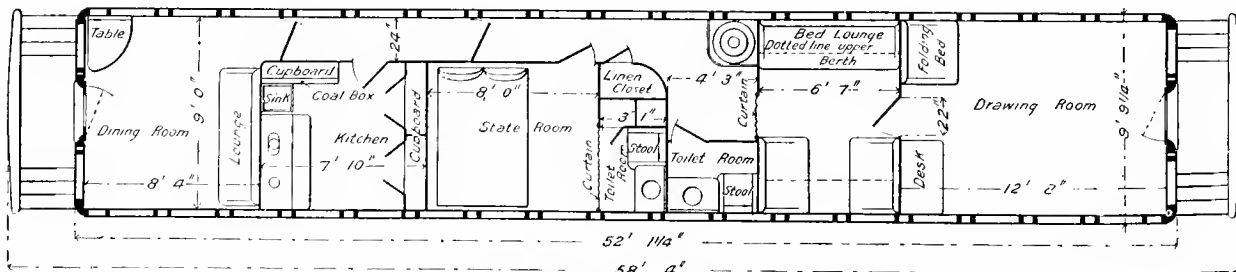

Fig. 199. Sectional Plan.
BUSINESS CAR, NEW YORK, LAKE ERIE & WESTERN RAILROAD.

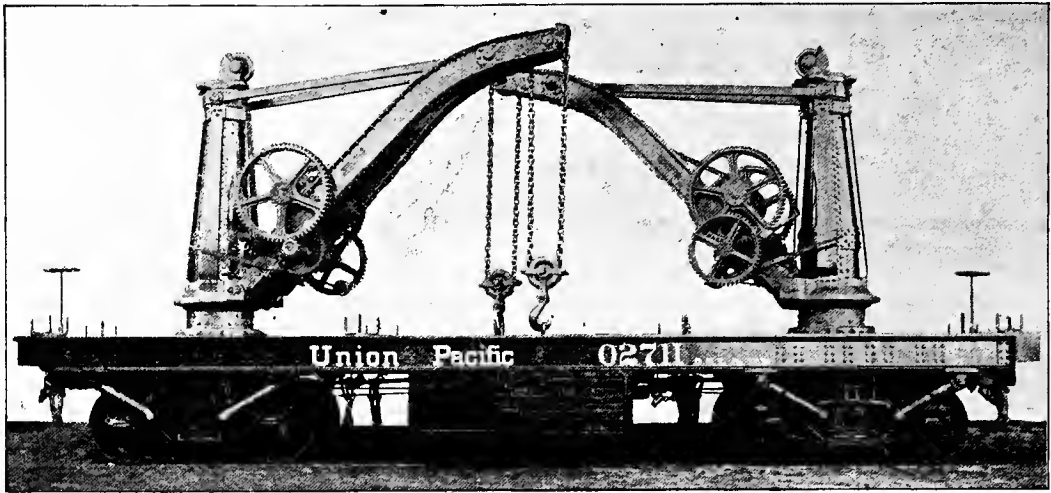

Fig. 206. WRECKING CAR, DOUBLE-HAND, UNION PACIFIC RAILWAY, BUILT BY INDUSTRIAL WORKS, BAY CITY, MICHIGAN. Capacity, 15 tons.

Numbers Refer to List of Names with Figs. 388-396.

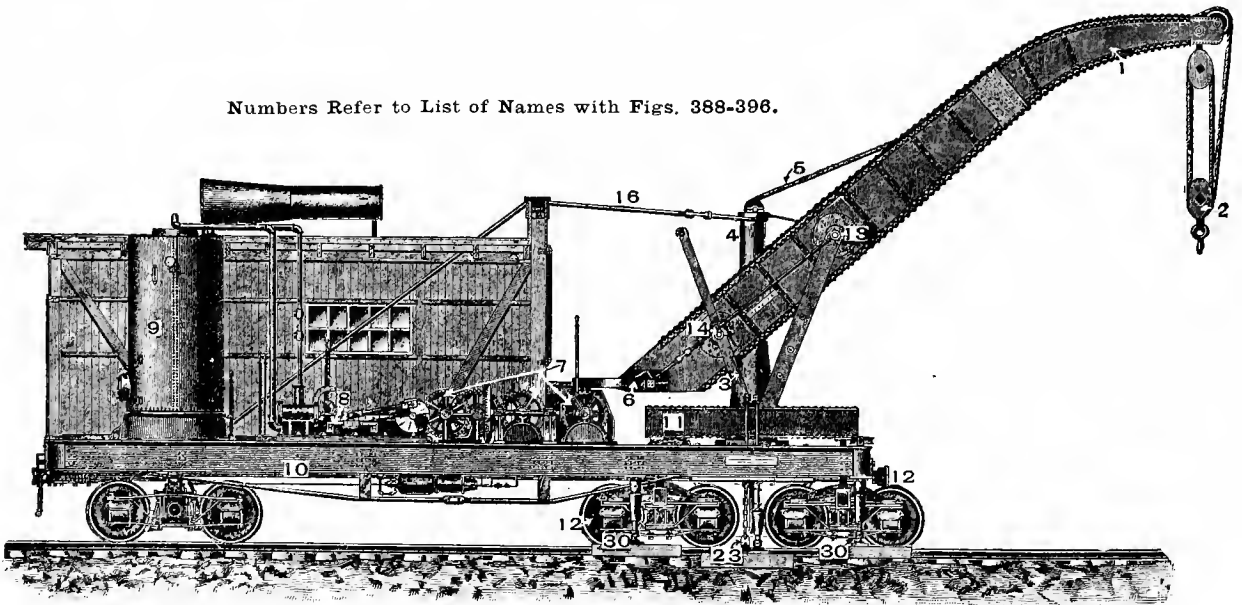

Fig. 207. STEAM WRECKING CRANE. INDUSTRIAL WORKS. Radius of arm, 22 ft. Capacity, 40 tons.

Numbers Refer to List of Names with Figs. 405-407.

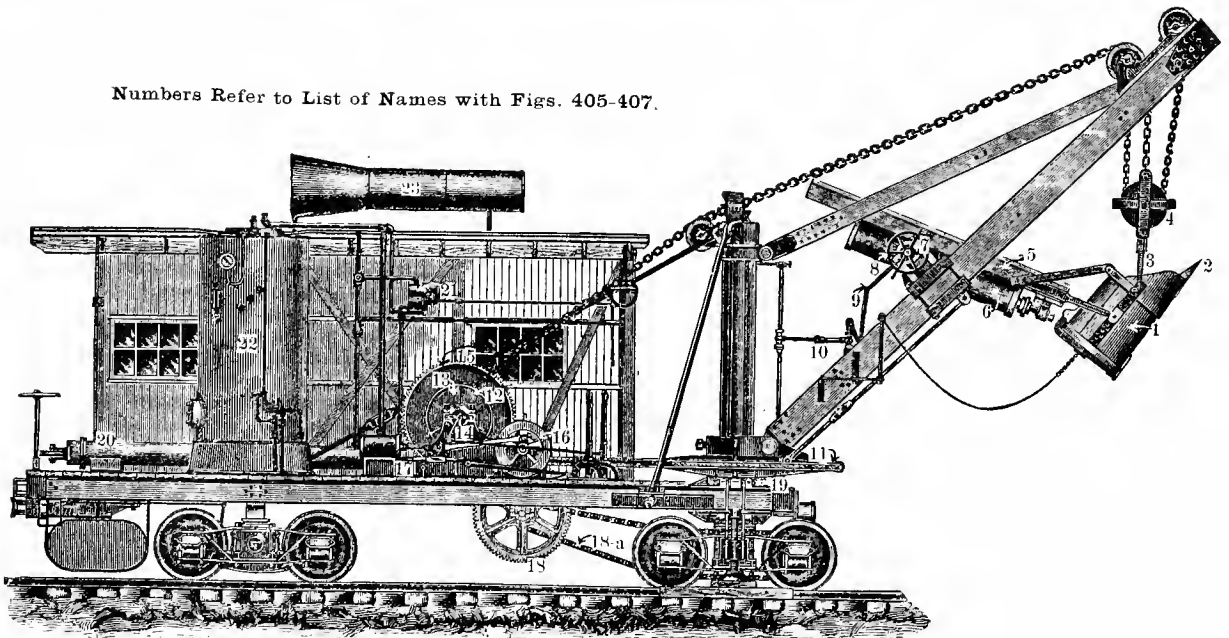

Fig. 208. STEAM SHOVEL. INDUSTRIAL WORKS.

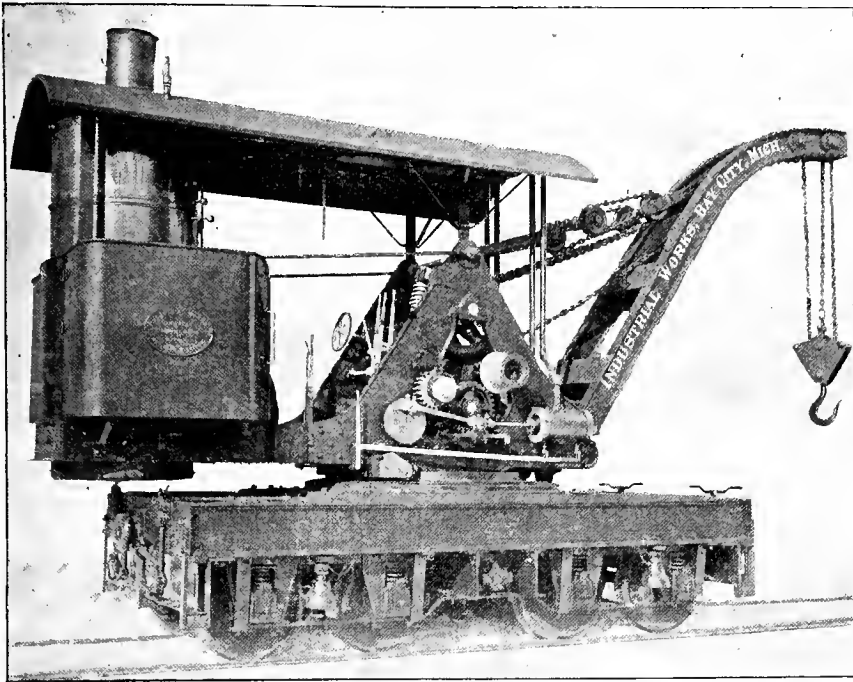

Fig. 209. LOCOMOTIVE CRANE, BUILT BY THE INDUSTRIAL WORKS. Capacity, 12 tons.

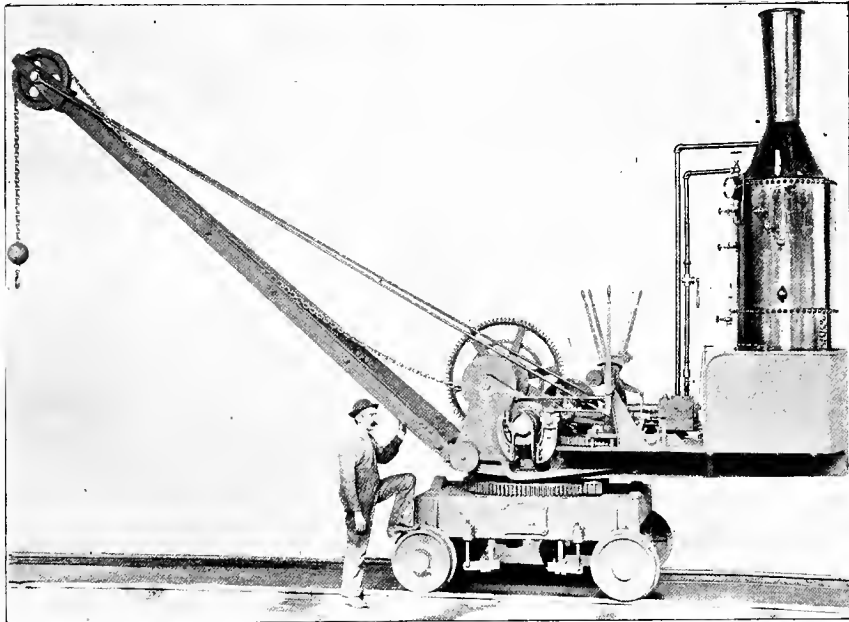

Fig. 210. LOCOMOTIVE CRANE. YALE & TOWNE MANUFACTURING COMPANY.
Radius of boom, 16 ft. Capacity, 4,000 lbs.

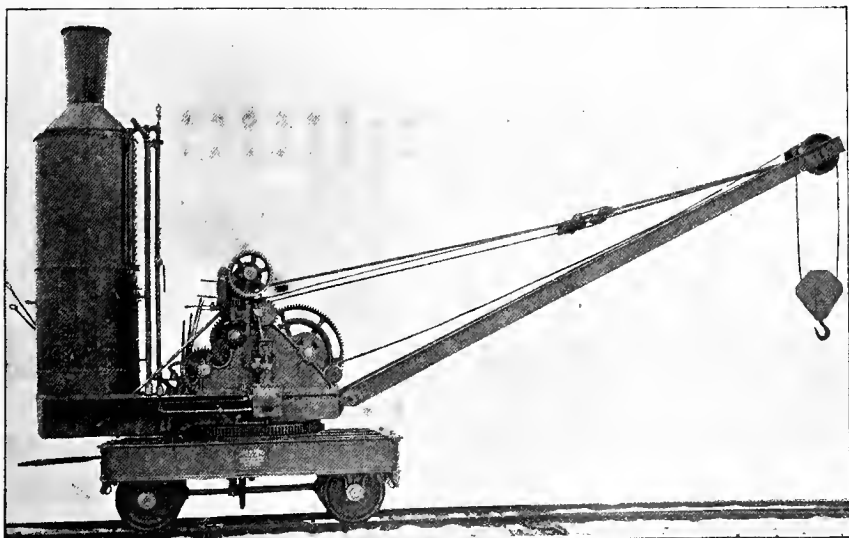

Fig. 211. LOCOMOTIVE CRANE. YALE & TOWNE MANUFACTURING COMPANY.
Radius of Boom, 26 ft. 6 ins. Capacity, 10 tons. Weight 56,000 lbs. (Details are shown in Figs. 389-391.)

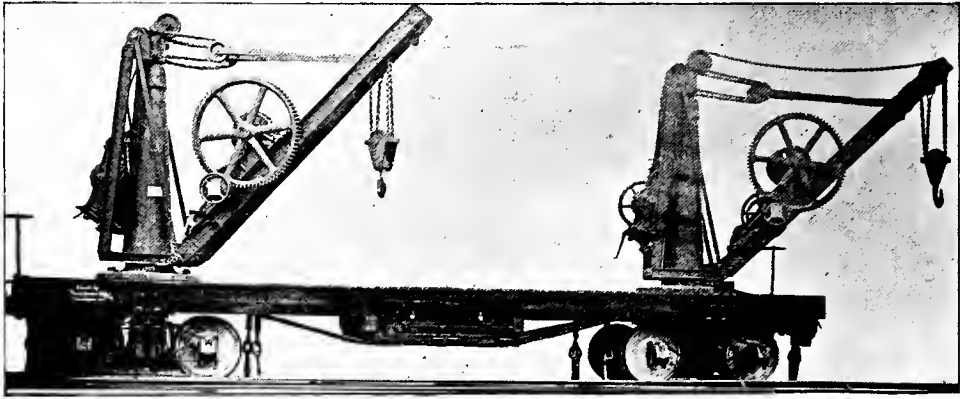

Fig. 212. DOUBLE DERRICK-CAR, YALE & TOWNE MANUFACTURING COMPANY.
Lifting Capacity, 20,000 lbs.

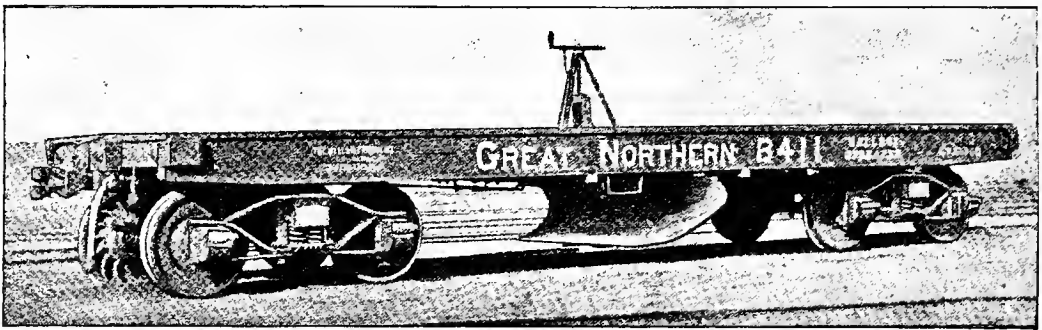

Fig. 213. RODGERS BALLAST DISTRIBUTING CAR.
With Plow Raised for Transportation.

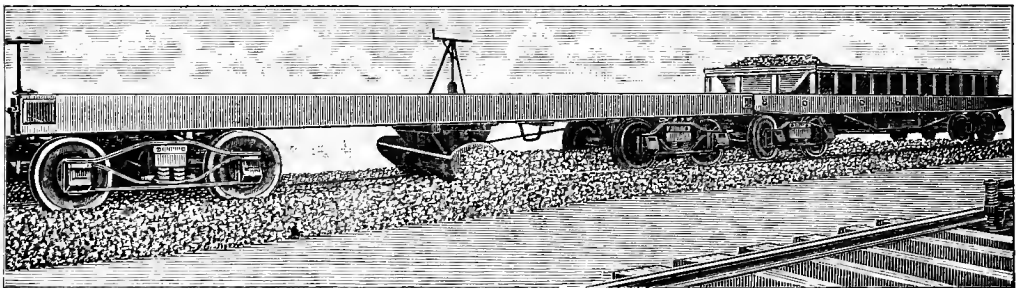

Fig. 214. BALLAST PLOW, PRECEDED BY A HOPPER-BOTTOM BALLAST CAR.



Fig. 215. CLEARANCE CAR, PENNSYLVANIA RAILROAD.



Fig. 216. CLEARANCE CAR, PENNSYLVANIA RAILROAD.

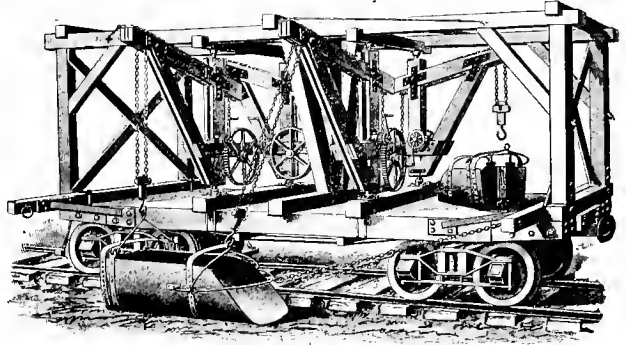

Fig. 217. RAILROAD DITCHING CAR, THE AMERICAN.

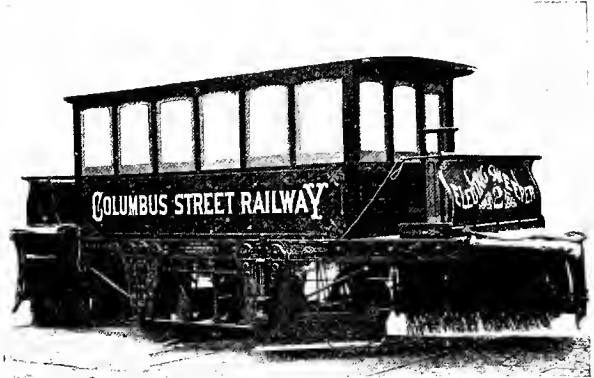

Fig. 217a. SWEEPING CAR, FOR ELECTRIC ROADS.

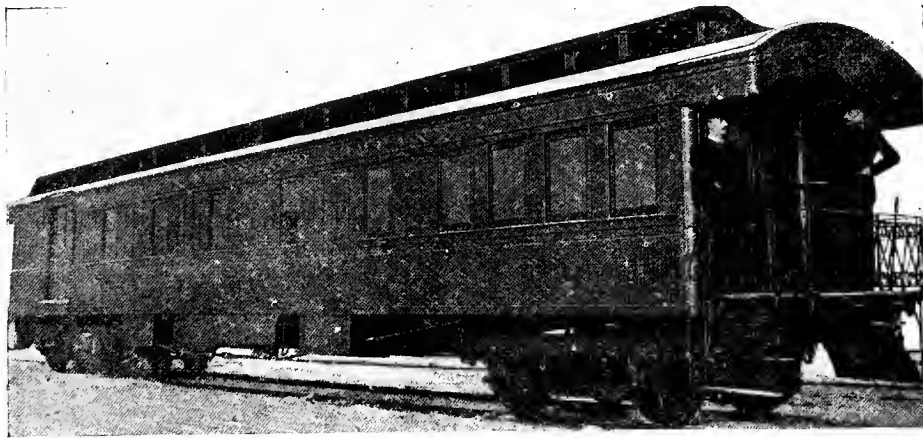

Fig. 218. AIR BRAKE INSTRUCTION CAR, WESTINGHOUSE AIR BRAKE COMPANY.

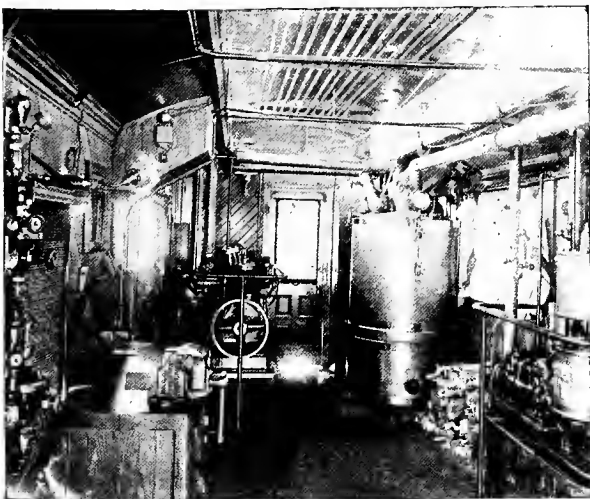

Fig. 219. INTERIOR AIR BRAKE INSTRUCTION CAR.

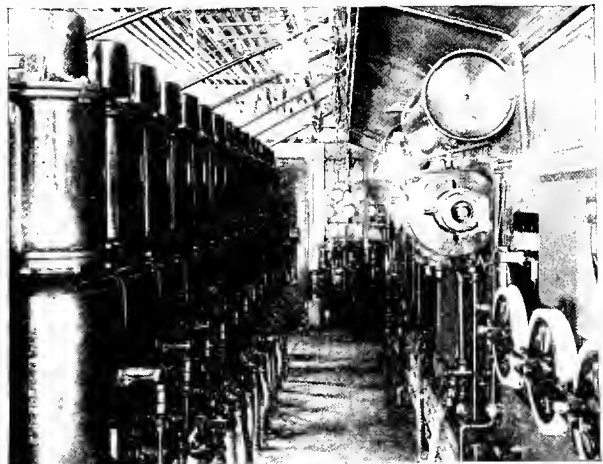

Fig. 220. INTERIOR AIR BRAKE INSTRUCTION CAR.

WESTINGHOUSE AIR BRAKE COMPANY.

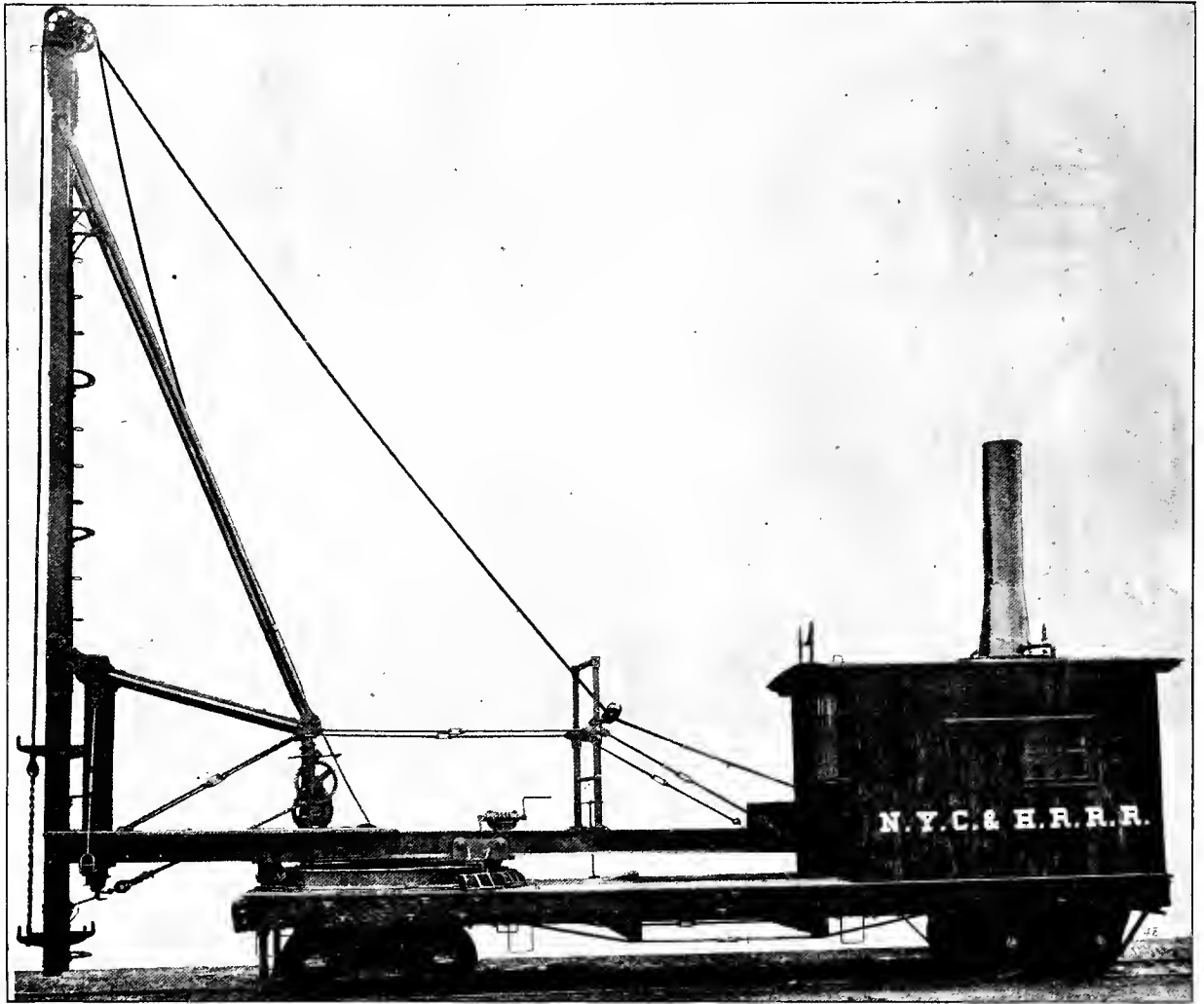

Fig. 221. PILE DRIVER CAR. NEW YORK CENTRAL & HUDSON RIVER RAILROAD.
Built by the Industrial Works, Bay City, Michigan. The framing of Pile Driver Cars is shown in Figs. 397-400.

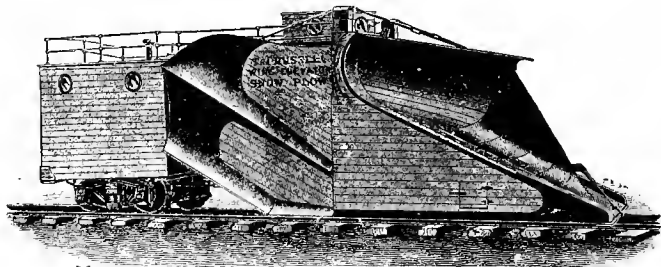

Fig. 222. THE RUSSELL WING ELEVATOR SNOW PLOW.

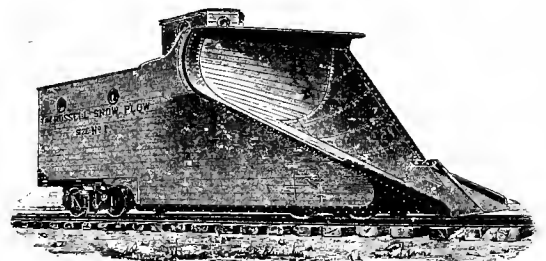

Fig. 223. THE RUSSELL SNOW PLOW.



Fig. 224. THE RUSSELL DOUBLE TRACK SNOW PLOW. (The framing is shown in Fig. 409.)
Snow Plows built by The Ensign Manufacturing Company.

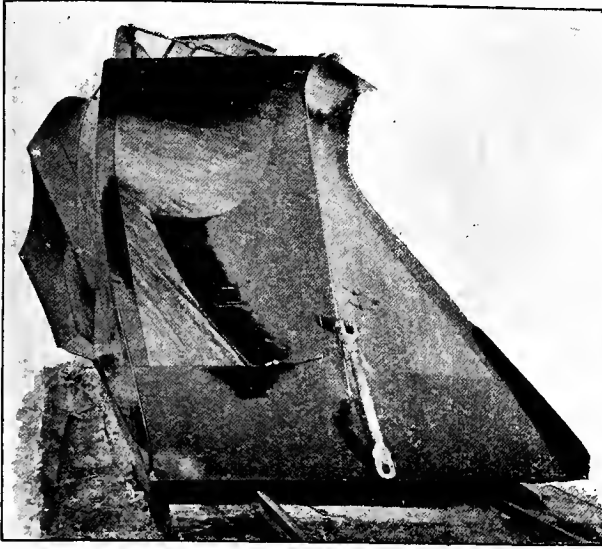

Fig 225. THE RUSSELL WING SNOW PLOW.
Built by the Ensign Manufacturing Company.

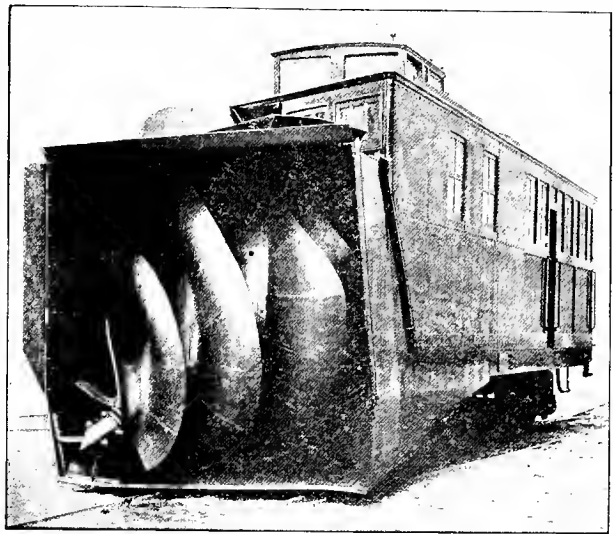

Fig. 226. THE JULL CENTRIFUGAL SNOW EXCAVATOR.



Fig. 227. THE JULL CENTRIFUGAL SNOW EXCAVATOR.
Built by The Jull Manufacturing Company, Brooklyn.

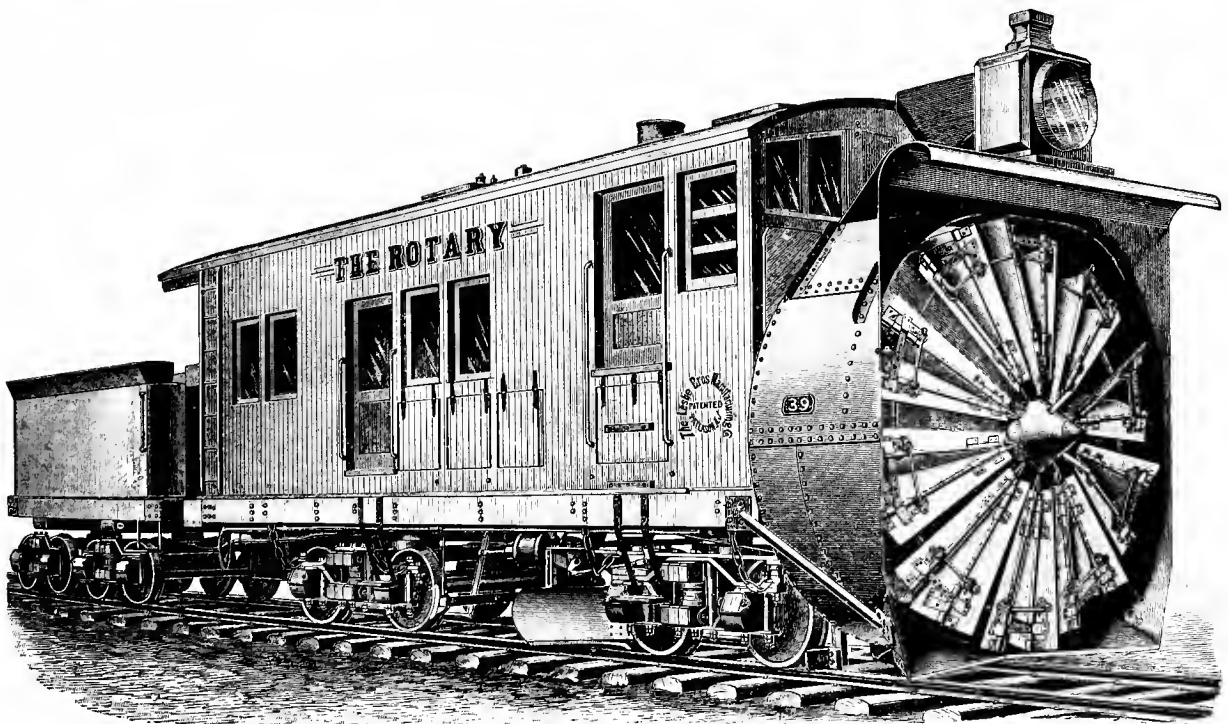

Fig. 228. THE ROTARY STEAM SNOW SHOVEL.
Built by The Leslie Brothers, Paterson, N. J.

CAR-BODIES.

Numbers refer to List of Names with Figs. 265-266.

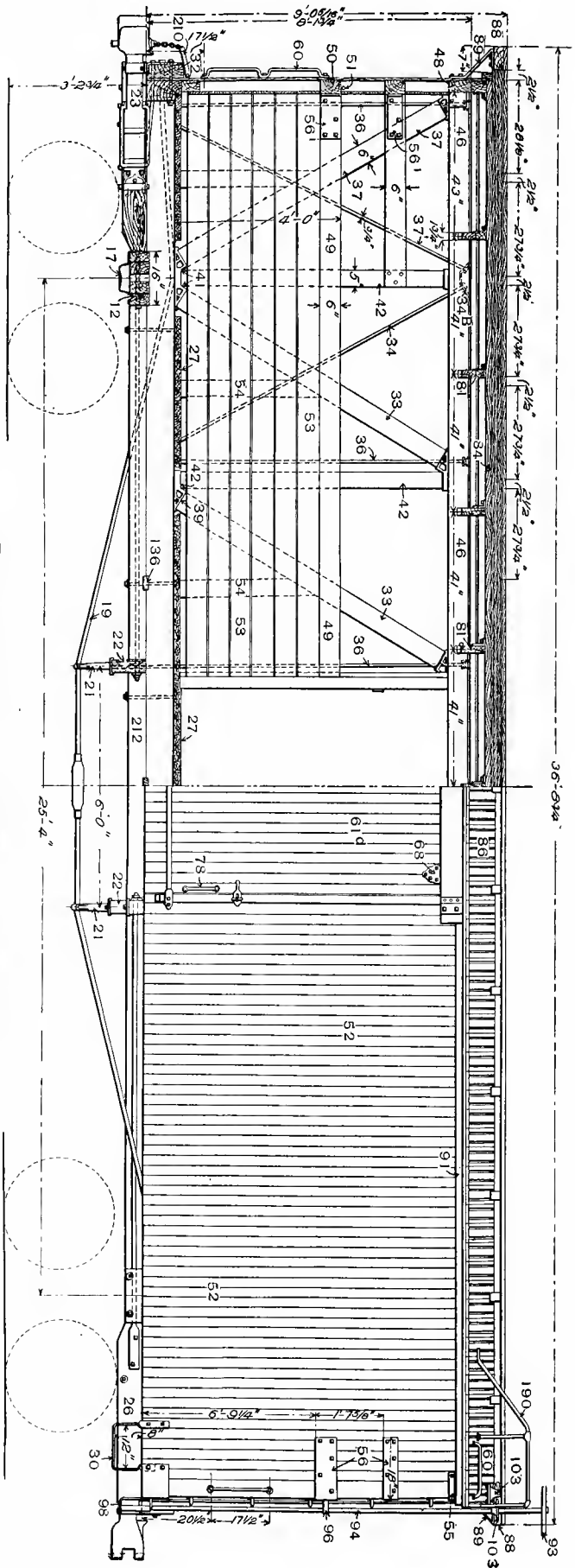

Fig. 229. Half Longitudinal Section and Half Side Elevation.

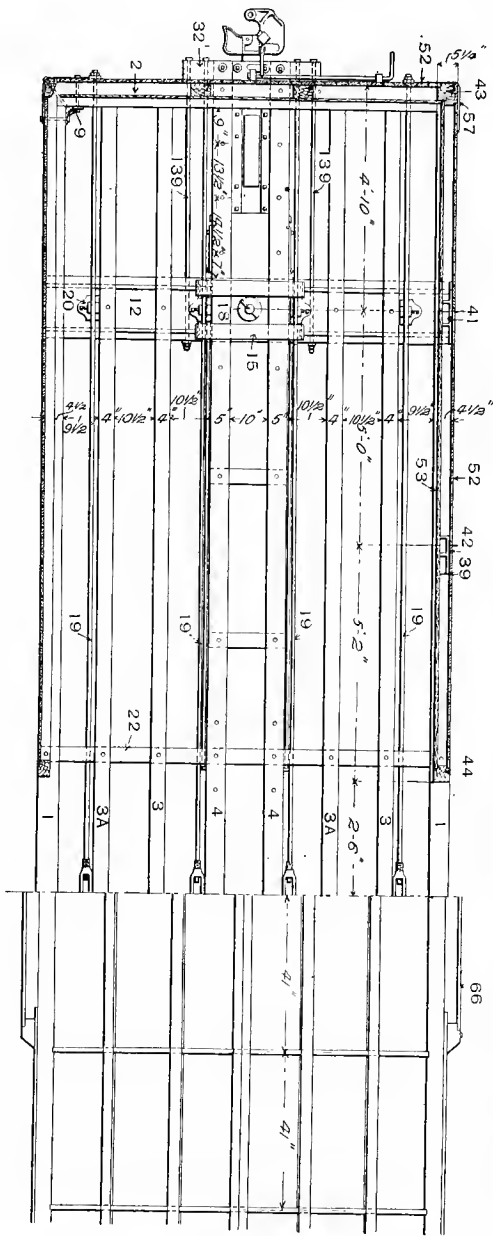
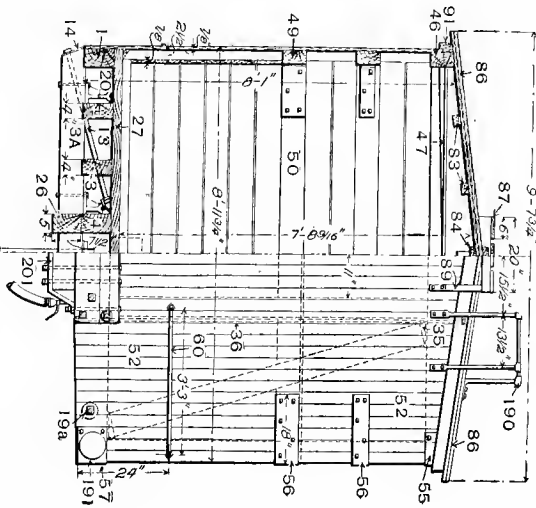

Fig. 230. Half Plan of Underframe and Part Plan of Roof.

BOX-CAR BODY, NEW YORK CENTRAL & HUDSON RIVER RAILROAD.
Length, 35 ft. Capacity, 60,000 lbs. Weight, with trucks, 30,000 lbs.



Numbers Refer to List of Names of Parts with Figs. 265-266.

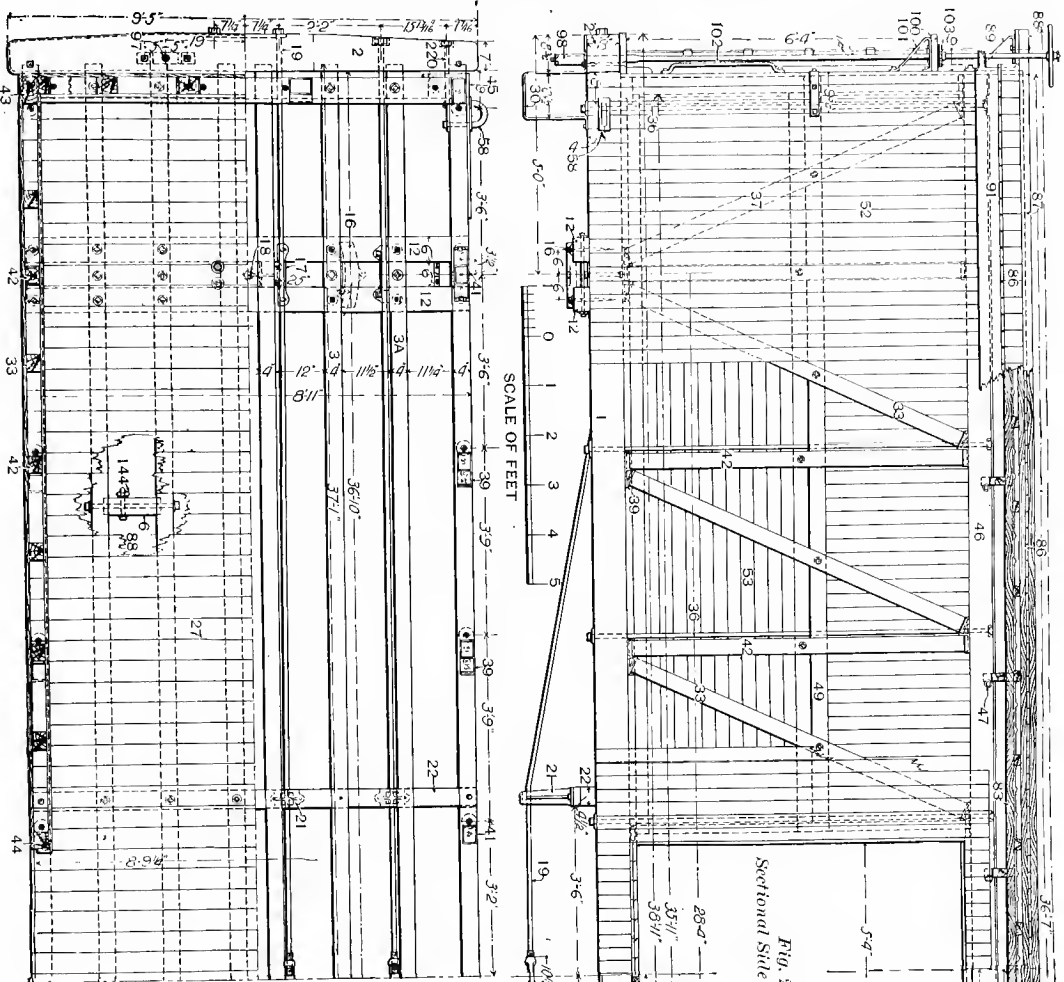

Fig. 232.
Sectional Side Elevation.

Fig. 233. Half Plan showing Framing.

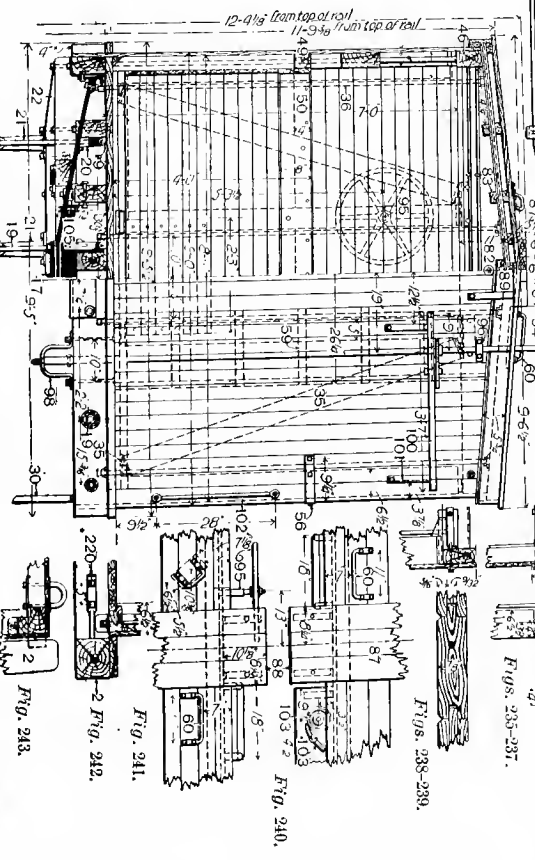
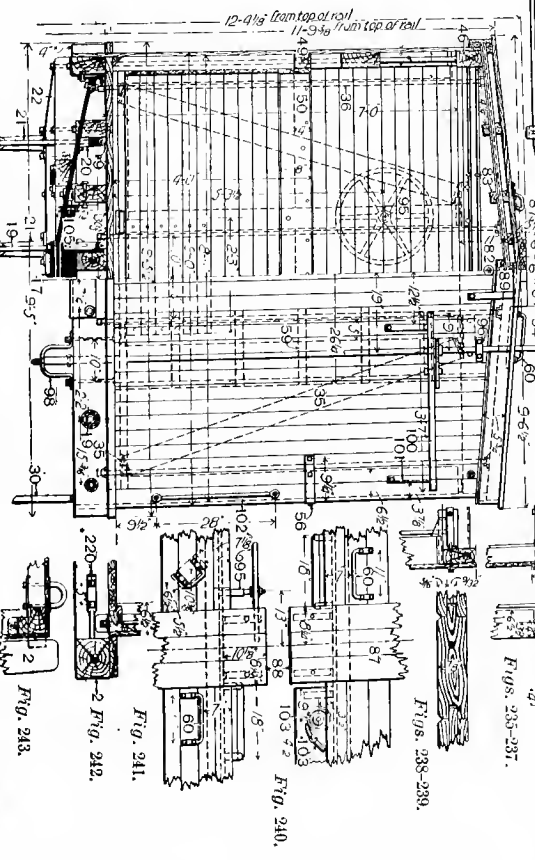

Fig. 234. Half Cross Section and Half End Elevation. Figs. 235-243. Details of Framing.



Figs. 238-239.

Figs. 235-237.

Fig. 240.

Fig. 241.

2 Fig. 242.

Fig. 243.

BOX-CAR BODY, PENNSYLVANIA RAILROAD.
Outside Endsill, Pratt Truss, Horizontal Brake Shaft, Iron Body Bolster.
General View shown in Fig. 2.)

Numbers Refer to List of Names of Parts with Figs. 265-266.

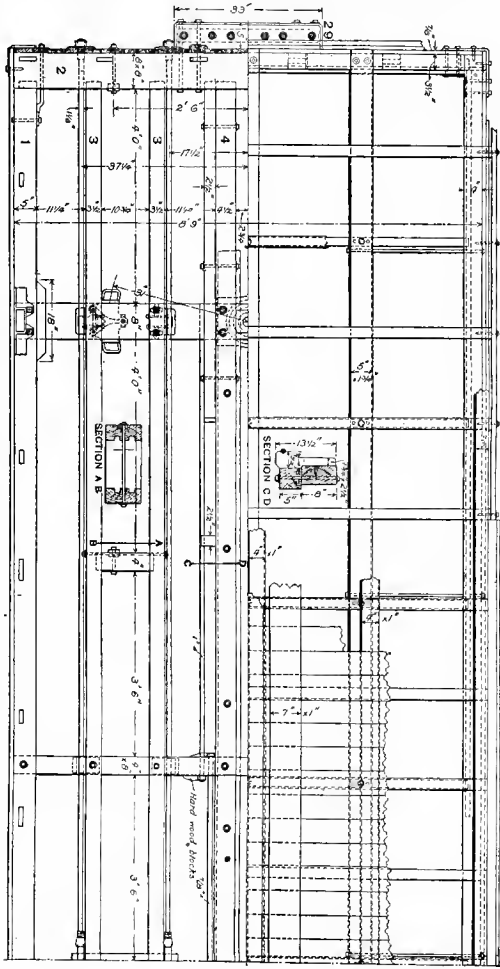

Fig. 245. Half Plan showing Roof and Underframing.

BOX-CAR BODY. LAKE SHORE & MICHIGAN SOUTHERN RAILWAY.

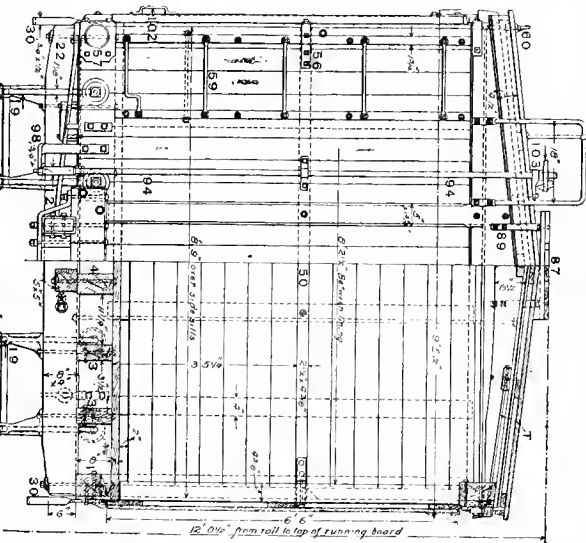

Fig. 246. Half End Elevation and Half Cross Section.

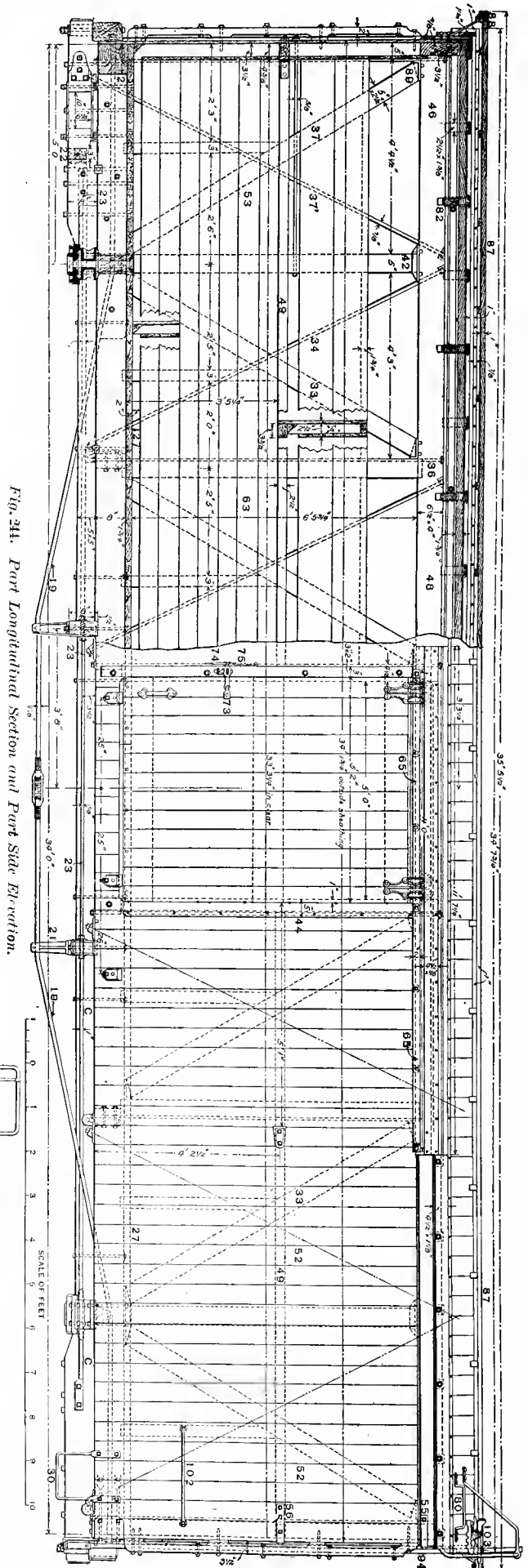

Fig. 244. Part Longitudinal Section and Part Side Elevation.

Numbers Refer to List of Names of Parts with Figs. 265-266.

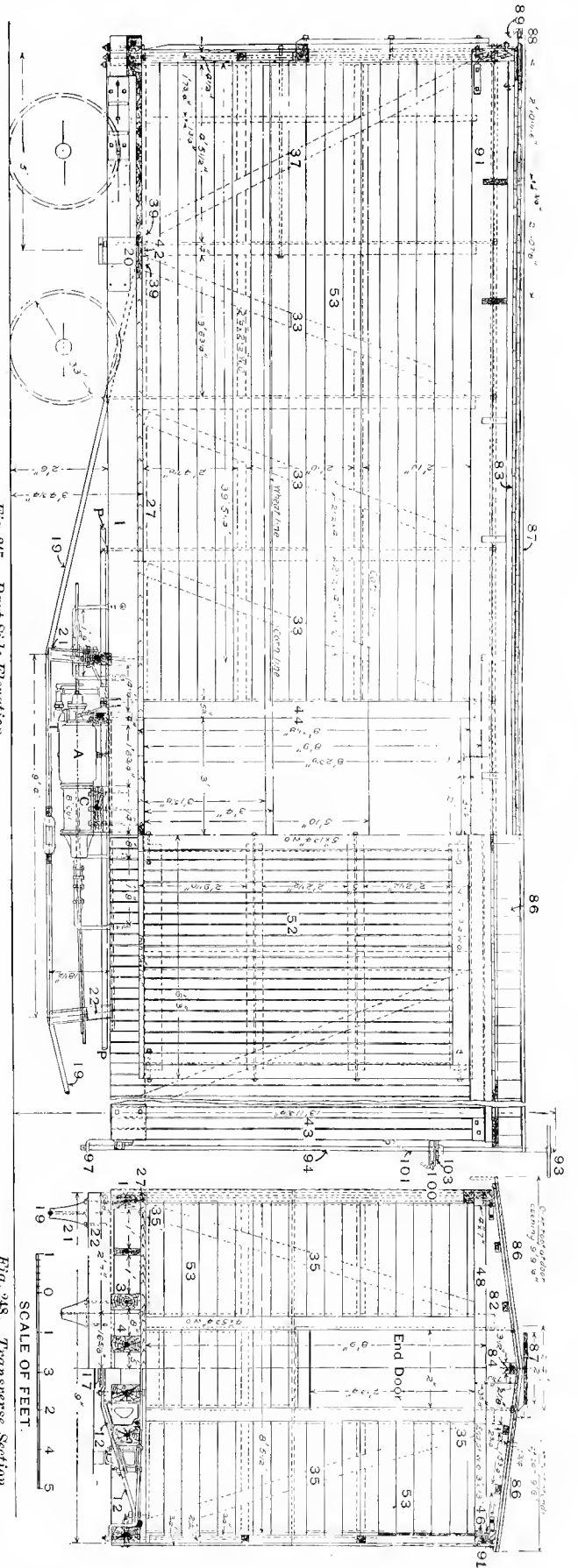

Fig. 247. Part Side Elevation.

Fig. 248. Transverse Section.

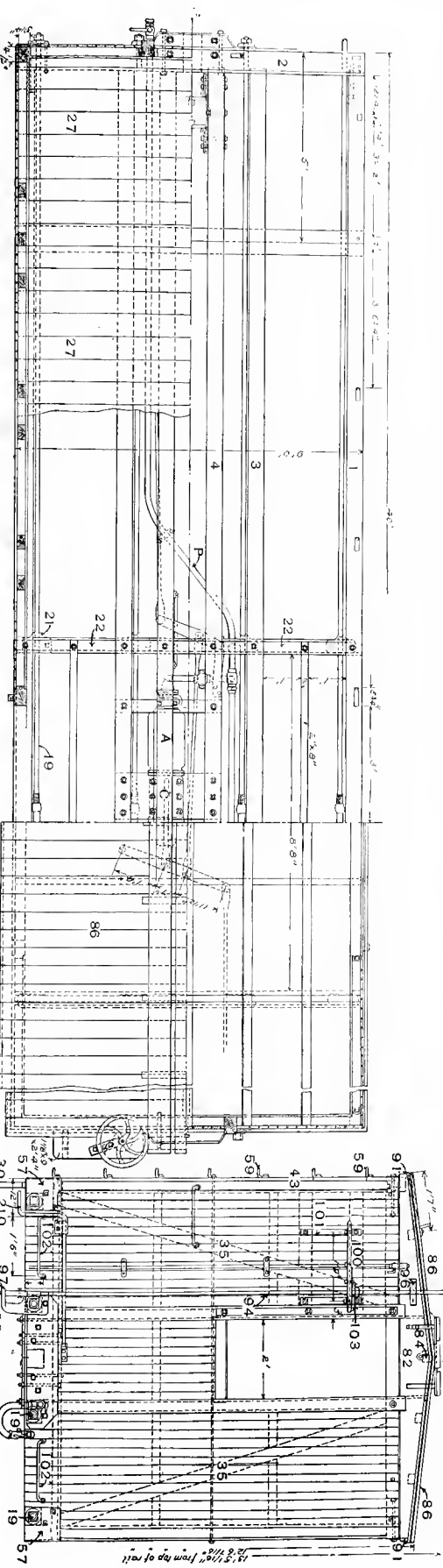
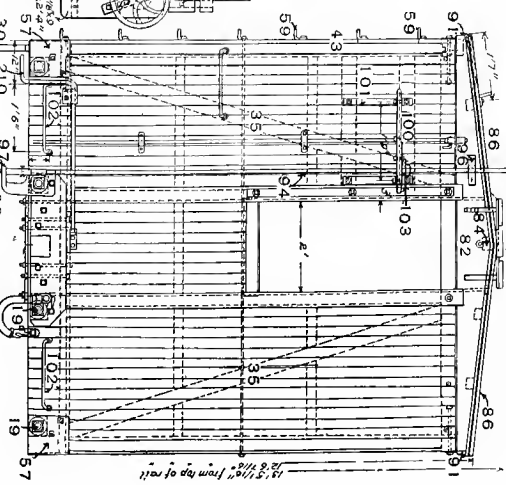

Fig. 249. Part Plan of Roof and Underframing.

FURNITURE-CAR BODY. CHICAGO, BURLINGTON & QUINCY RAILROAD.
 Length, 40 ft. Inside height, 8 ft. 9 ins. Capacity, 50,000 lbs. Weight, 31,850 lbs.
 Drawn Bar is placed between Sills. (A General View is shown in Fig. 4.)

Fig. 250. End Elevation.



Numbers refer to List of Names of Parts with Figs. 265-266.

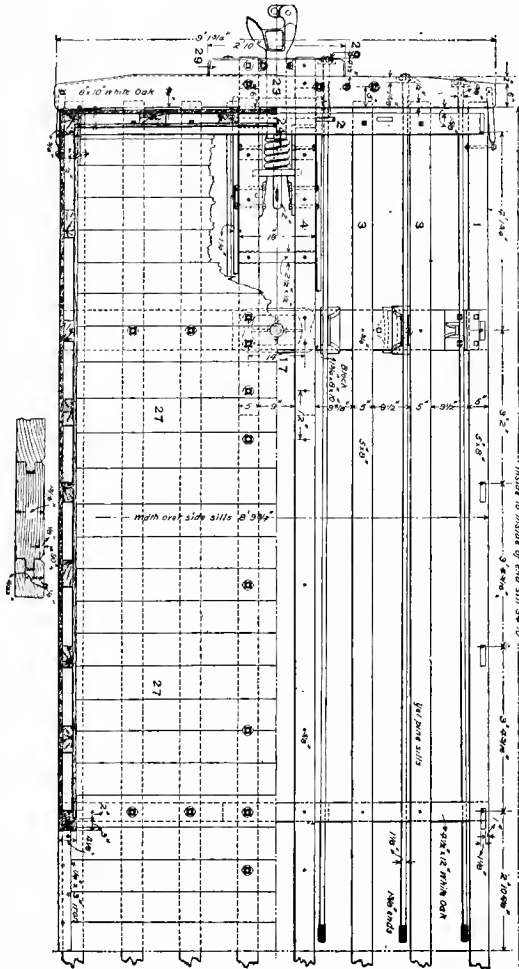

Fig. 252. Half Plan Showing Underframing and Floor.
BOX-CAR BODY. CLEVELAND, CINCINNATI, CHICAGO & ST. LOUIS RAILWAY.

Fig. 253. Half End Elevation and Half Cross Section.

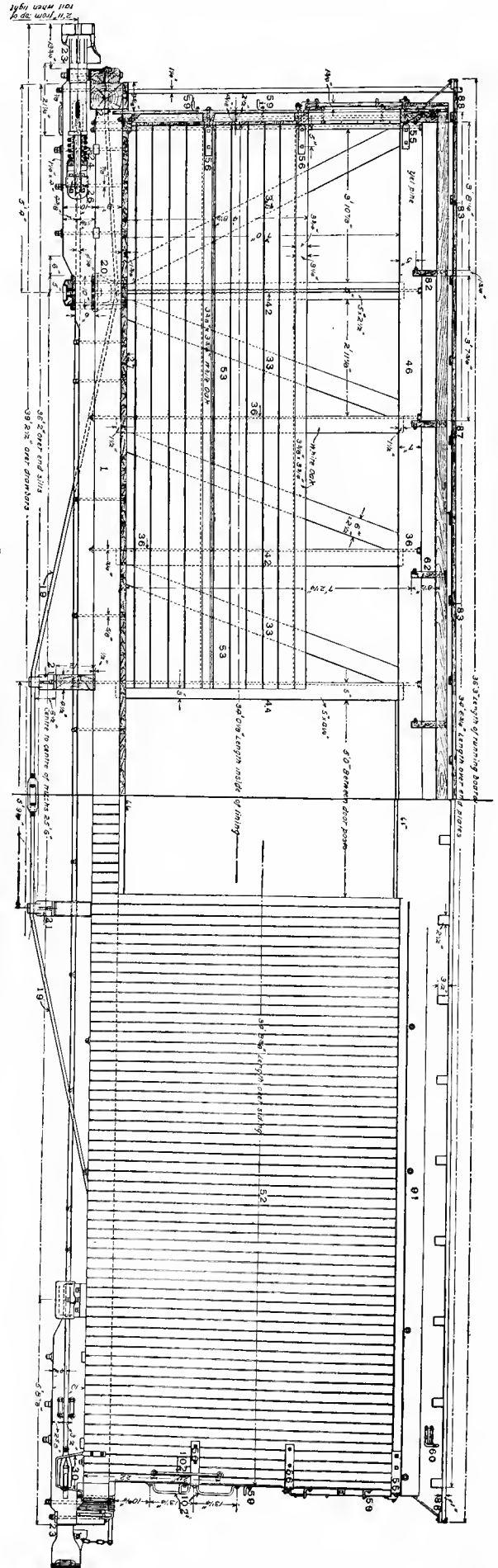
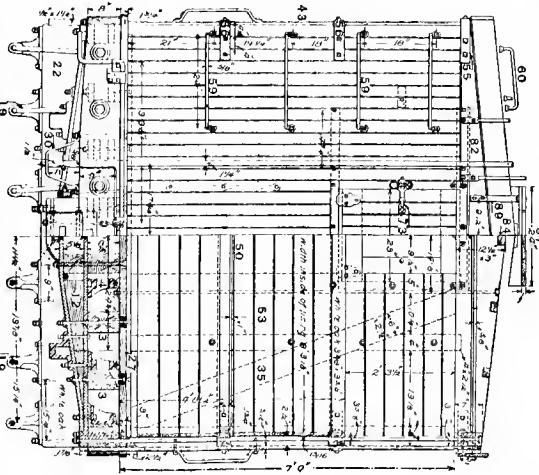
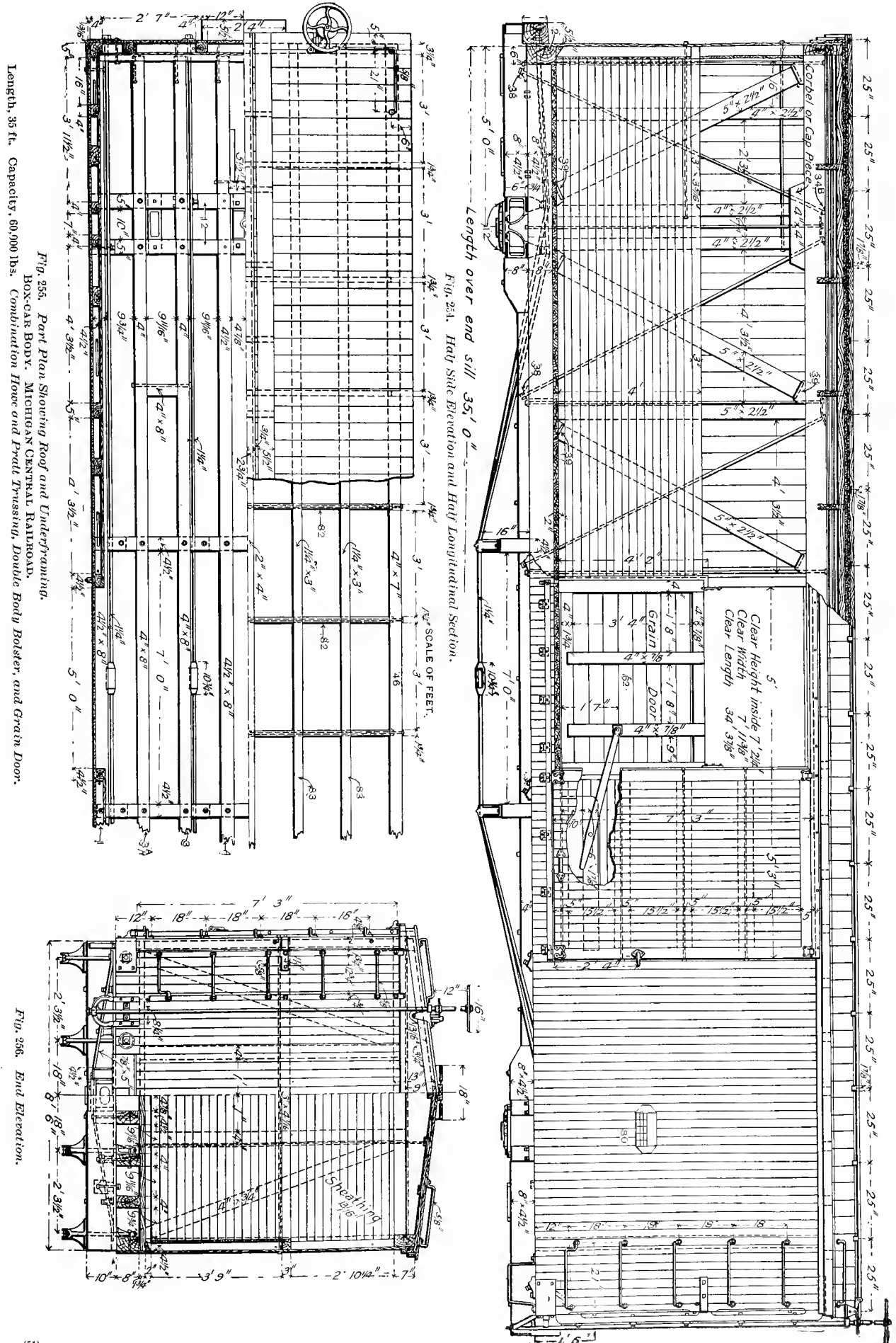

Fig. 251. Half Longitudinal Section and Half Side Elevation.

Numbers refer to List of Names of Parts with Figs. 265-266.



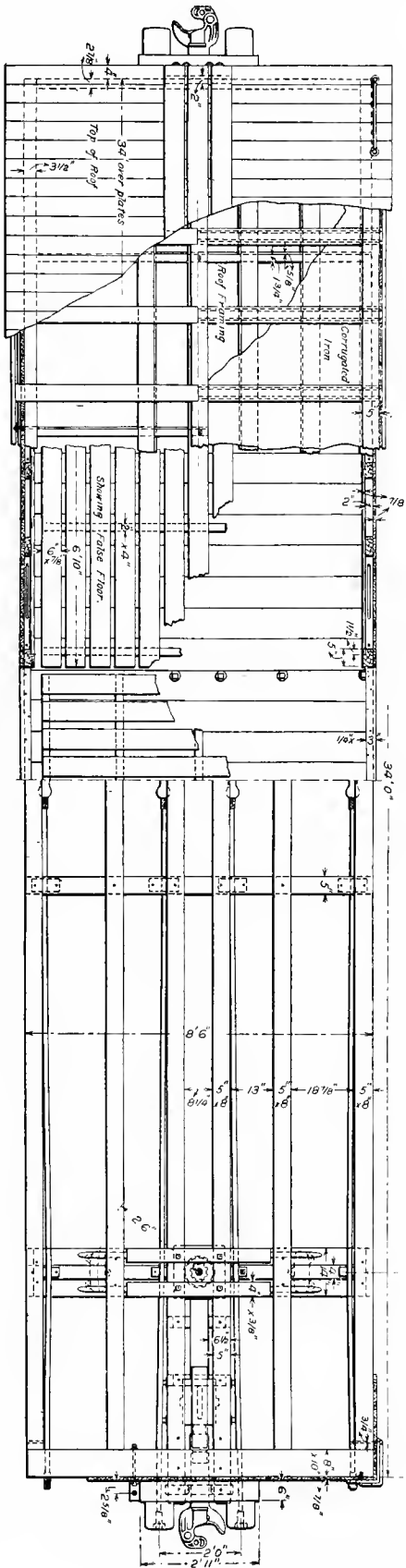
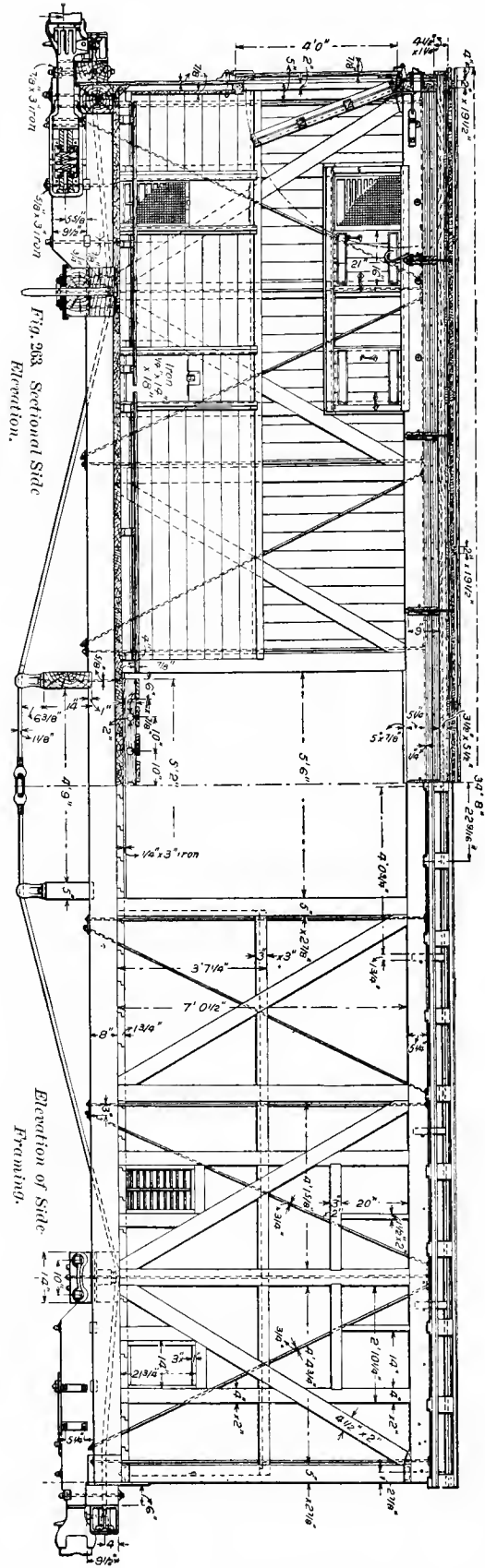

Fig. 264. Sectional Plan of Roof and Underframe.
 FRUIT-CAR BODY. CINCINNATI, NEW ORLEANS & TEXAS PACIFIC RAILWAY.
 Length, 35 ft. 3 ins. Capacity, 40,000 lbs. Weight, 34,800 lbs.



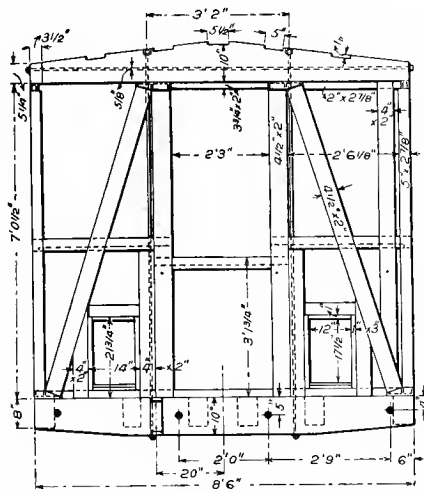

Fig. 265. End Elevation of Framing.

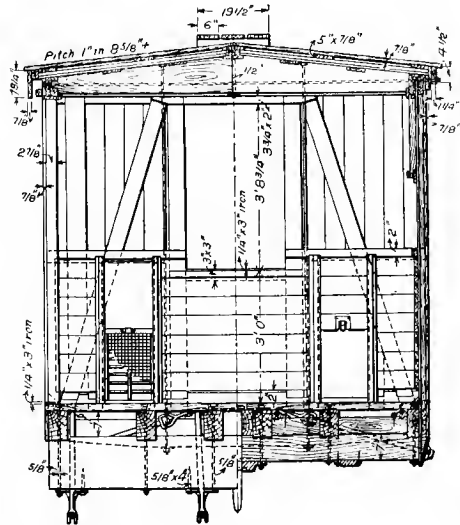

Fig. 266. Cross Sections through Door and Bolster.

VENTILATED FRUIT-CAR BODY. CINCINNATI, NEW ORLEANS & TEXAS PACIFIC RAILWAY.

LIST OF NAMES OF PARTS OF BOX-CAR BODIES. Figs. 229-266.

- | | | | |
|---|--|--------------------------------|---|
| 1. Side Sill. | 32. Buffer-block (same as 29). | 60. Hand-hold. | 103. Brake Ratchet-wheel. |
| 2. End-Sill. | 32a. Same as 32'. | 61. Grated Door. | 103'. Brake-pawl. |
| 3. Inner Intermediate-sill. | 32'. Buffer-beam. | 61d. Door. | 104. Horizontal Brake-shaft Chain. |
| 3a. Outer Intermediate-sill. | 33. Brace. | 62. Grain door. | 105. Brake-shaft Chain Sheave. |
| 4. Center-Sill. | 34. Brace-rod. | 63. Grain-door Rod. | 138. Drawbar Cross-timber. |
| 5. Short Floor timber. | 34'. End Brace-rod. | 64. Door-sill. | 139. Draw-gear Tie-rod. |
| 6. Brake-hanger Timber. | 34b. Double Counterbrace-rod Plate-washer. | 65. Top Door-track. | 141. Train Signal-lamp. |
| 7. Floor-timber Distance-block. | 34c. Counterbrace-rod Plate-washer. | 66. Bottom Door-track. | 142. Brake-head. |
| 8. Floor-timber Brace. | 35. End-brace. | 67. Door-track Bracket. | 143. Brake-beam. |
| 9. Sill Knee-iron. | 35'. End-brace Pocket. | 68. Door-hanger. | 144. Brake-hanger. |
| 10. Sill Tie-rod. | 36. Sill-and-plate Rod. | 69. Door-brace. | 145. Brake-lever. |
| 11. Transverse Floor-timber. | 37. Counterbrace. | 70. Door-shoe. | 146. Brake-lever Fulcrum. |
| 12. Body-bolster. | 37'. Counterbrace Rod. | 71. Open-door Stop. | 147. Brake-lever Guide. |
| 12'. Body-bolster Thimble. | 38. Brace-rod Washer. | 72. Closed-door Stop. | 148. Brake-lever Bracket. |
| 12a. Top Plate of Iron Body-bolster. | 39. Brace-pocket. | 73. Door-hasp. | 150. Brake-chain. |
| 12b. Bottom Plate of Iron Body-bolster. | 40. Same as 39. | 74. Door-pin. | 151. Brake-shaft Connecting-rod. |
| 13. Body-bolster Truss-rod. | 41. Double Brace-pocket. | 75. Door-pin Chain. | 152'. Brake-lever Connecting-rod. |
| 14. Body-bolster Truss rod Washer. | 42. Post. | 78. Door-handle. | 165. Journal-box. |
| 15. Body-bolster Truss-block. | 42'. Post-pocket. | 80. Card-rack. | 177. Door-cap. |
| 16. Body Side-bearing. | 43. Corner-post. | 81. Carline. | 186. Key-blocks. |
| 17. Body Center-plate. | 44. Door-post. | 82. Carline (same as 81). | 188. Brake-hanger Bolt. |
| 18. King-bolt or Center-pin. | 44w. Window-post. | 83. Purlin. | 190. Brake Hand-rail. |
| 19. Body Truss-rod. | 44'. Door-post Pocket. | 84. Ridge-pole. | 191. Push-pole Corner-iron. |
| 19a. Body Truss-rod Washer. | 45. Corner-post Pocket. | 86. Roof-boards. | 201. Drawbar Carry-iron. |
| 20. Body Truss-rod Saddle. | 46. Plate. | 86c. Ceiling (Fig. 262). | 210. Uncoupling-lever and Rod. |
| 21. Body Truss-rod Bearing. | 46s. Window-sill. | 87. Running-board. | 212. Draw-gear Tie-rod or Continuous Drawbar. |
| 22. Cross Tie-timber. | 46w. Window-cap. | 88. Running-board Extension. | 220. Sill Strap-bolt. |
| 23. Drawbar. | 47. Plate-rod. | 89. Running-board Bracket. | 222. Inside Upper-corner-plate. |
| 24. Draft-spring. | 48. End-plate. | 91. Fascia-board (same as 90). | A = Auxiliary Air Reservoir. |
| 25. Auxiliary Buffer-spring. | 49. Belt-rail. | 93. Brake Hand-wheel. | C = Brake-cylinder. |
| 26. Draft-timber. | 50. End Belt-rail. | 94. Brake-shaft. | P = Train-pipe. |
| 27. Floor. | 51. End Belt-rail Tie-rod. | 95. Horizontal Brake-shaft. | T = Triple-valve. |
| 28. Double-deck. | 52. Sheathing or Siding. | 96. Upper Brake-shaft Bearing. | V = Ventilators (Figs. 257-262). |
| 29. Buffer-block (same as 32). | 53. Inside Lining. | 97. Lower Brake-shaft Bearing. | |
| 30. Sill-step. | 54. Lining-strip. | 98. Brake-shaft Step. | |
| | 55. Upper Corner-plate. | 99. Brake-shaft Bracket. | |
| | 56. Middle Corner-plate. | 100. Brake-step. | |
| | 57. Lower Corner-plate. | 101. Brake-step Bracket. | |
| | 58. Roping-staple. | 102'. Hand-hold. | |
| | 59. Ladder-round. | | |

Numbers refer to Lists of Names of Parts on opposite and preceding pages.

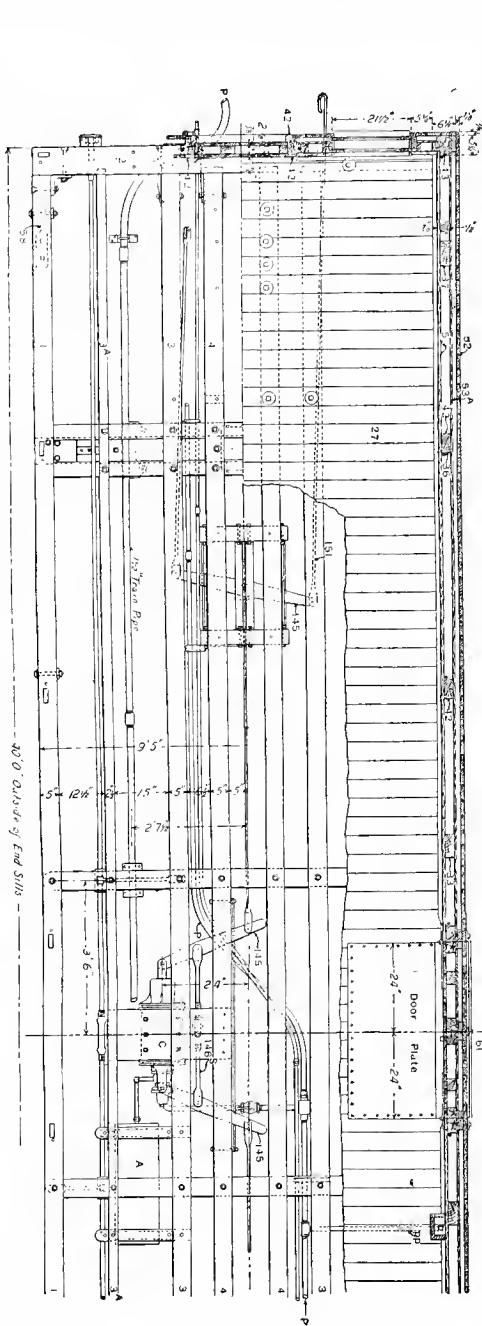

Fig. 269. Part Plan, showing Floor and Underframing.

MILK-CAR BODY. NEW YORK, LAKE ERIE & WESTERN RAILROAD.
Length, 40 ft. Capacity, 32,000 lbs., 288 Cans. Weight, 41,850 lbs.

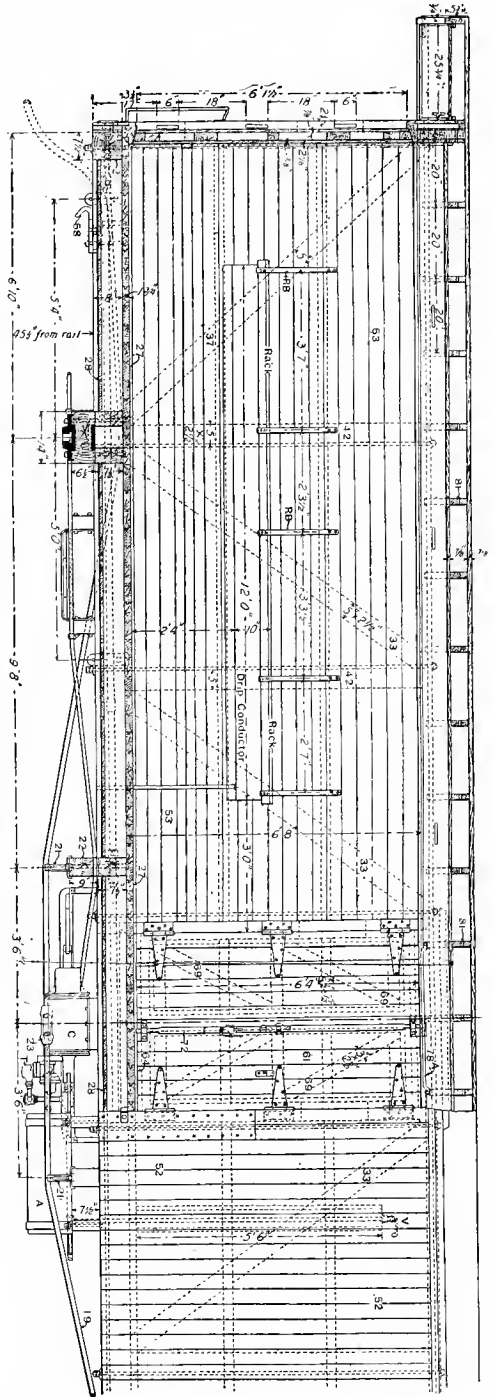

Fig. 267. Half Longitudinal Section and Port Side Elevation.

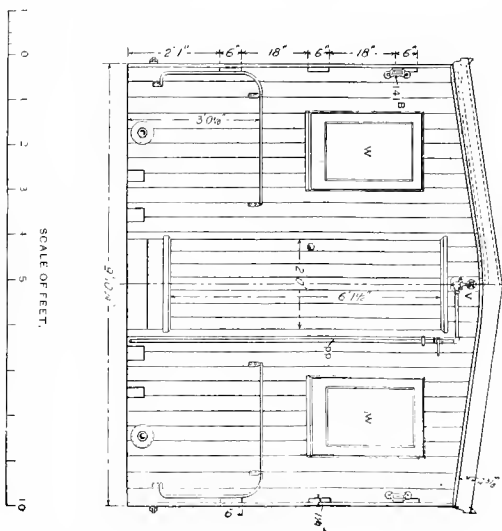

Fig. 270. End Elevation.

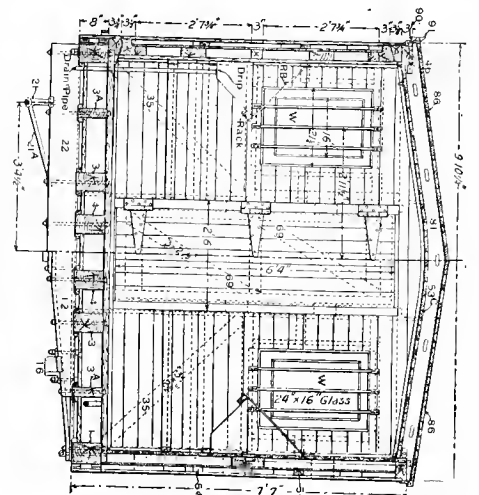

Fig. 268. Transverse Sections.

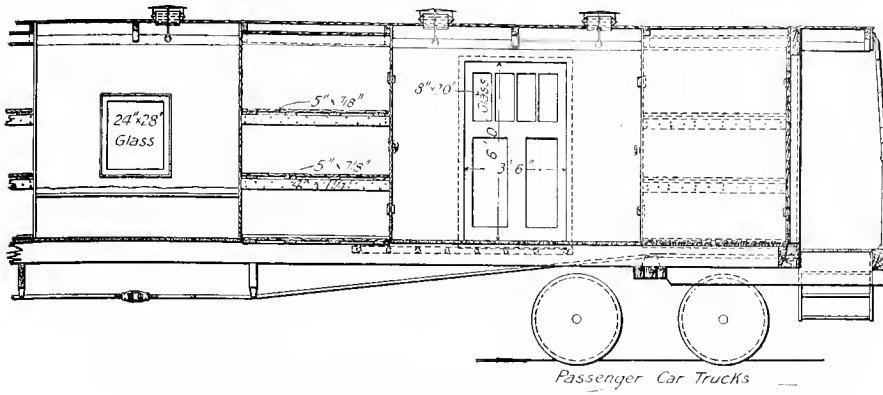

Fig. 271. Part Longitudinal Section.

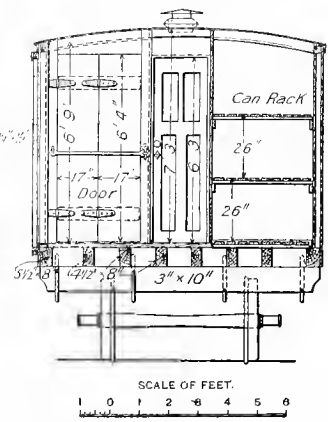

Fig. 272. Transverse Section.

NAMES OF PARTS SPECIAL TO Figs. 267-270.

- 21A. Body Truss-rod Bearing Brace.
- 23. Turnbuckle Truss Rod.
- 28. Deafening Ceiling.
- 42. Door-post.
- 53c. Ceiling.
- 53A. Intermediate Lining.
- 61. Door.
- 72. Door-rod or Bar.
- 90. Eaves Moulding.
- 141B. Signal-lamp Bracket.
- 146S. Brake-lever Tie-rod.
- 78A. Door Grab-iron.
- pp. Pipe to Conductor's Valve.
- RB. Can-rack Bracket.
- V. Conductor's Valve.
- W. Windows.

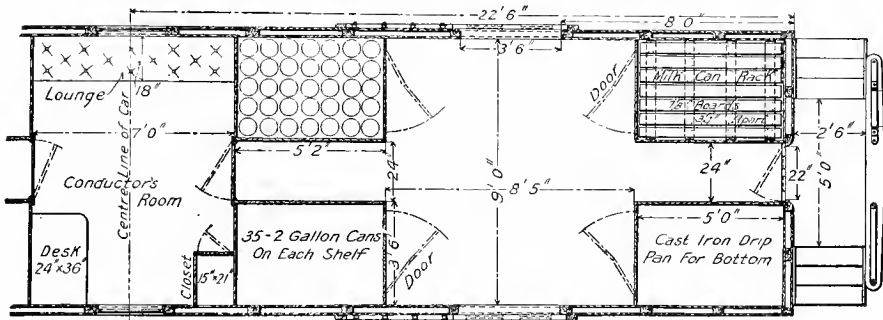

Fig. 273. Plan of Floor.

MILK-CAR BODY, FOR SMALL CANS, OLD COLONY RAILROAD.

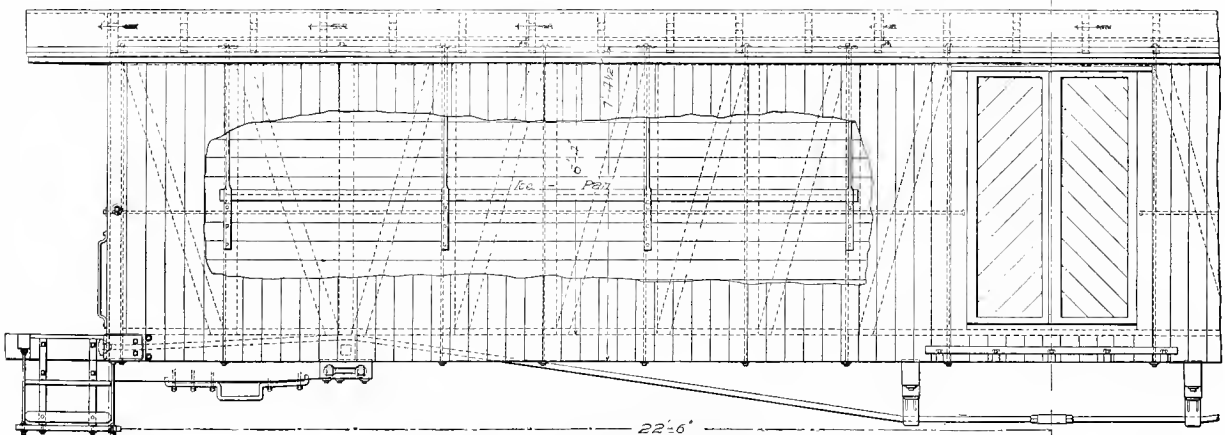

Fig. 273a. Sectional, Side Elevation.

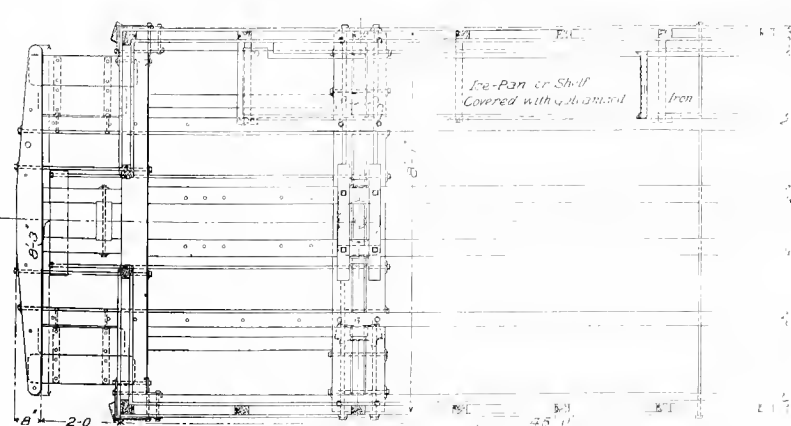

Fig. 273b. Part Plan Showing Underframe.

MILK-CAR BODY. NEW YORK, ONTARIO & WESTERN RAILWAY.

Length, 45 ft. Capacity, 60,000 lbs. or 280 10-gallon cans. Weight, 31,000 lbs.

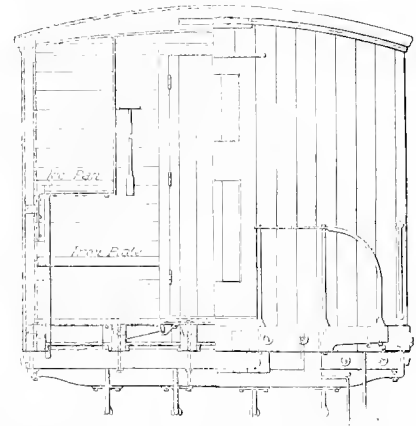

Fig. 273c. Half Cross Section and Elevation.

Fig. 275. Half Plan of Roof Frame and Underframe.

REFRIGERATOR-CAR BODY. HANRAHAN SYSTEM OF REFRIGERATION.

Half Plan of Floor and Roof.

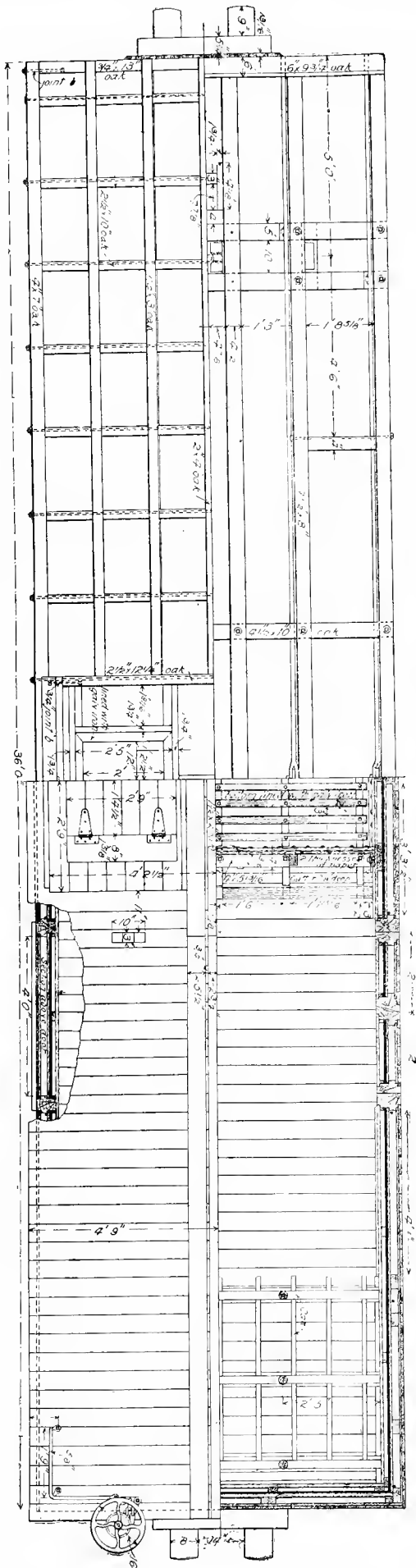
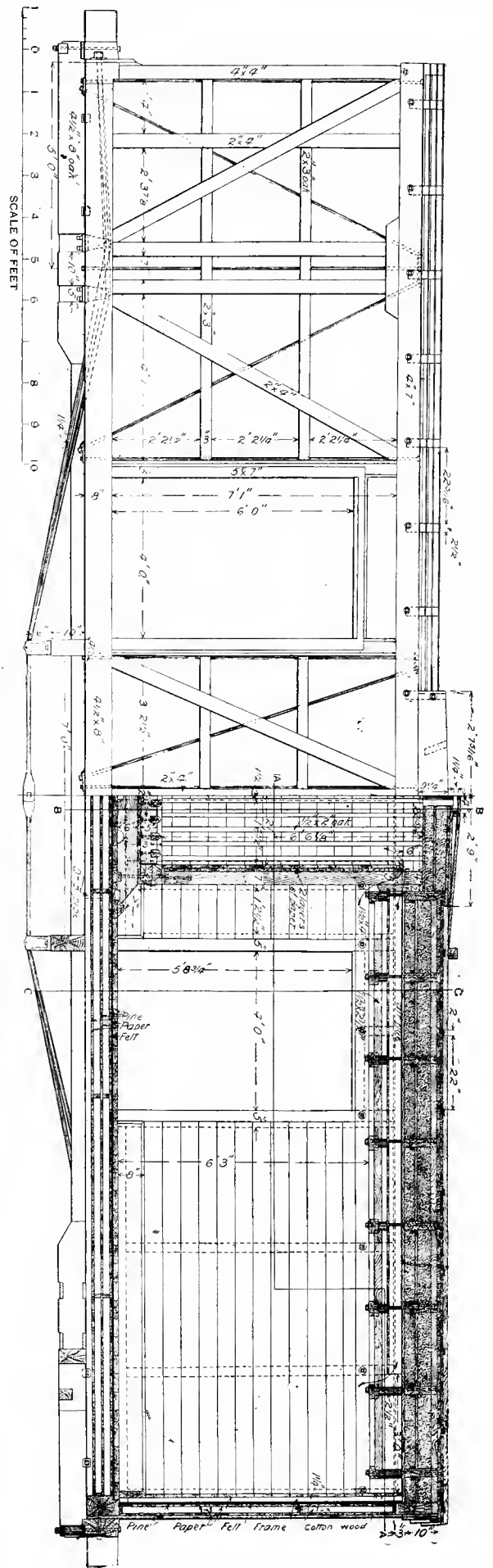

Fig. 274. Half Side Elevation of Fronting and Half Longitudinal Section.



Numbers refer to List of Names on Following Page.

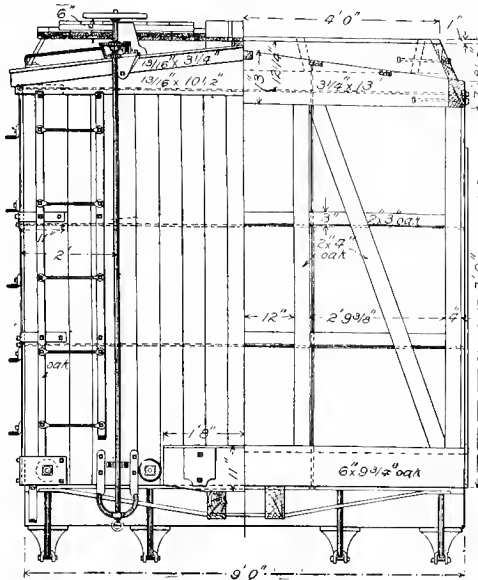

Fig. 276. End Elevation.

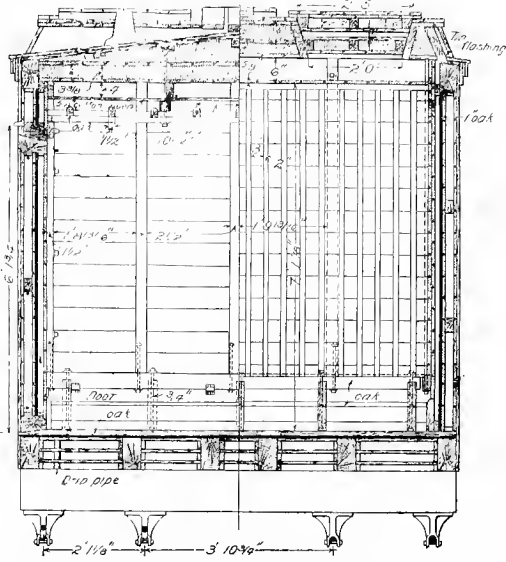

Fig. 277. Transverse Sections.

REFRIGERATOR-CAR BODY. HANRAHAN SYSTEM OF REFRIGERATION.

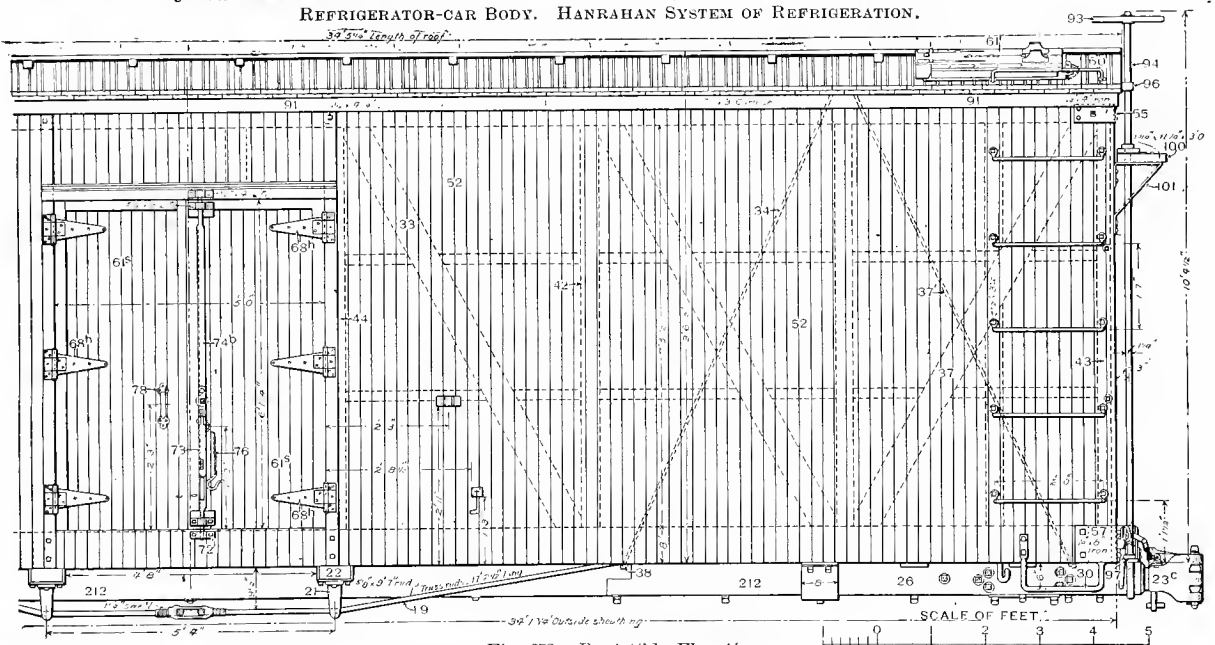

Fig. 278. Part Side Elevation.

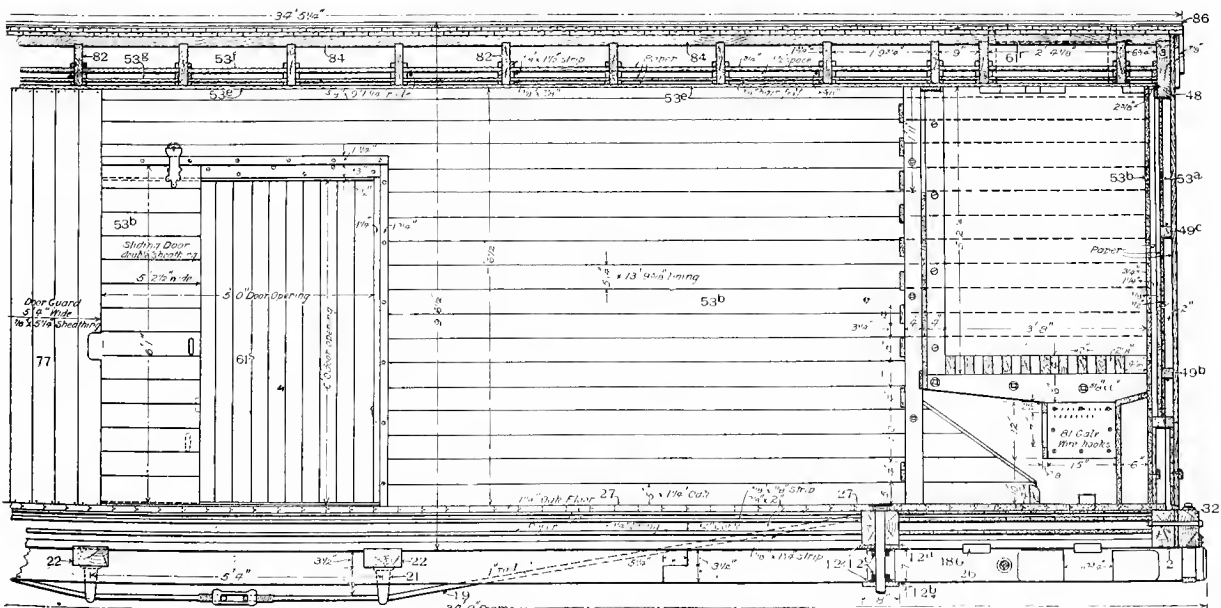

Fig. 279. Part Longitudinal Section.

REFRIGERATOR-CAR BODY. CHICAGO, MILWAUKEE & ST. PAUL RAILWAY.

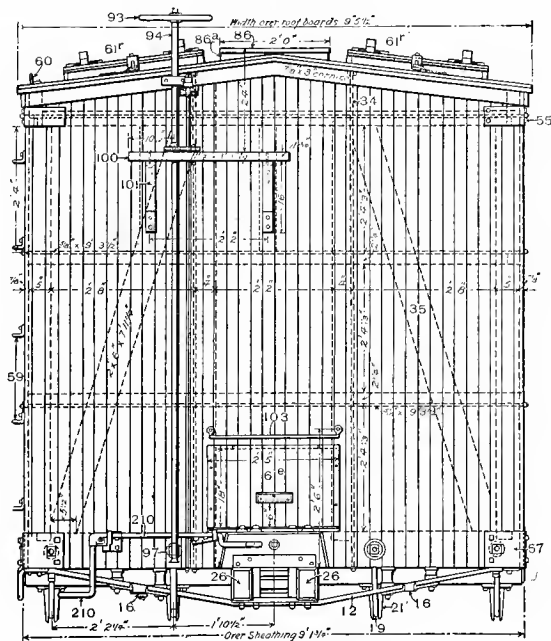

Fig. 280. End Elevation.

REFRIGERATOR-CAR BODY, C, M. & ST. PAUL RAILWAY.

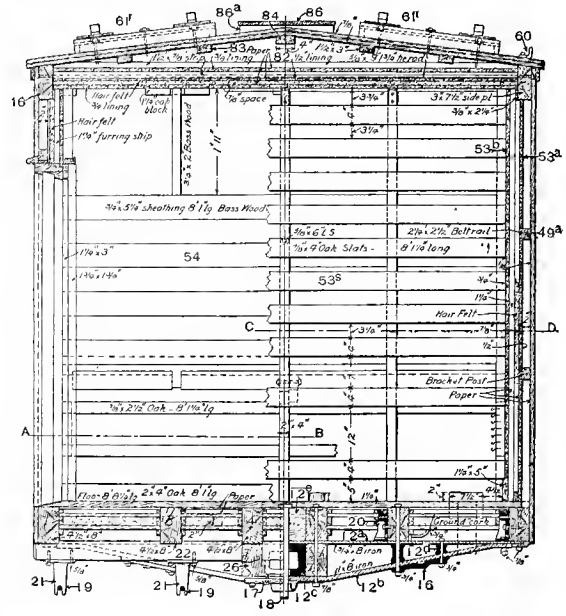

Fig. 281. Transverse Sections.

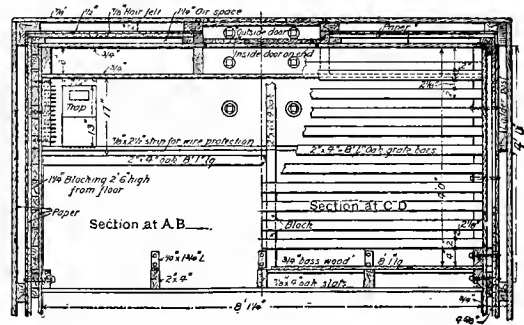

Fig. 282. Sectional Plan Showing Ice Box.

NAMES OF PARTS OF REFRIGERATOR CARS. Figs. 278-286.

- | | | |
|--------------------------------|---------------------------------------|--------------------------------|
| 2. End-sill. | 42. Post. | 68b. Door-hinge. |
| 12. Body-bolster. | 38. Brace-rod Washer. | 72. Door-bolt Bracket. |
| 12a. Top Bolster-plate. | 43. Corner-post. | 73. Door-hasp. |
| 12b. Bottom Bolster-plate. | 44. Door-post. | 74b. Door-bolt or Bar. |
| 12c. Bolster Center-casting. | 46. Plate. | 76. Door-pin Chain. |
| 12d. Body-bolster Thimble. | 48. End-plate. | 77. Door-guard. |
| 12e. Body-bolster Truss-block. | 49a. Side Bell-rail. | 82. Carline. |
| 16. Body Side-bearing. | 49b. End Bell-rail. | 83. Purlin. |
| 17. Body Center-plate. | 49c. End Bell-rail. | 84. Ridge-pole. |
| 18. King-bolt. | 52. Sheathing. | 86. Running-board. |
| 19. Body Truss-rod. | 53b. Inside Lining. | 86a. Running-board Blocking. |
| 20. Body Truss-rod Saddle. | 53a. Intermediate Lining. | 91. Fucia-board. |
| 21. Body Truss-rod Bearing. | 53s. Guard Lining-strips for Ice-box. | 93. Brake-wheel. |
| 22. Cross-tie-timber. | 53e. Inner Overhead Lining. | 94. Brake-shaft. |
| 23c. Coupler. | 53f. Outer Overhead Lining. | 97. Lower Brake-shaft Bearing. |
| 26. Draft-timber Floor. | 53g. Intermediate Overhead Lining. | 100. Brake-step. |
| 30. Sill-step. | 54. Lining-stud. | 101. Brake-slep Bracket. |
| 32. Buffer-beam. | 55. Upper Corner-plate. | 102. } Hand-hold. |
| 33. Brace. | 57. Lower Corner-plate. | 103. } |
| 34. Brace-rod. | 59. Ladder-round. | 186. Key-blocks. |
| 34'. End Brace-rod. | 60. Hand-holds. | 210. Uncoupling-lever and Rod. |
| 35. End-brace. | 61e. End-door. | 212. Buffing Sub-sill. |
| 37. Counterbrace. | 61r. Roof-door for Ice. | |
| 37'. Counterbrace-rod. | 61s. Door. | |

Numbers refer to Lists of Names of Parts on this and the opposite page.

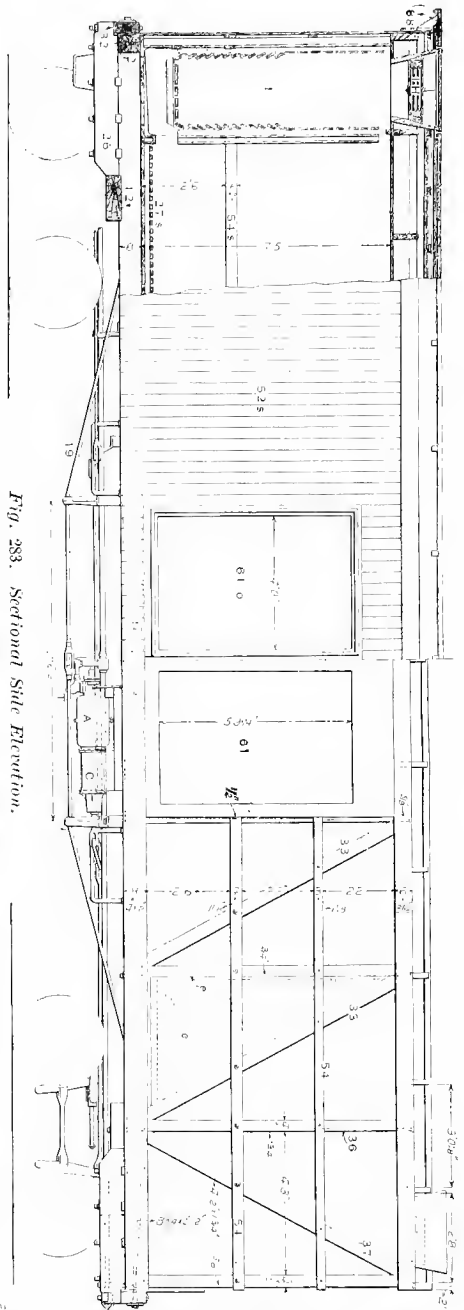

Fig. 283. Sectional Side Elevation.

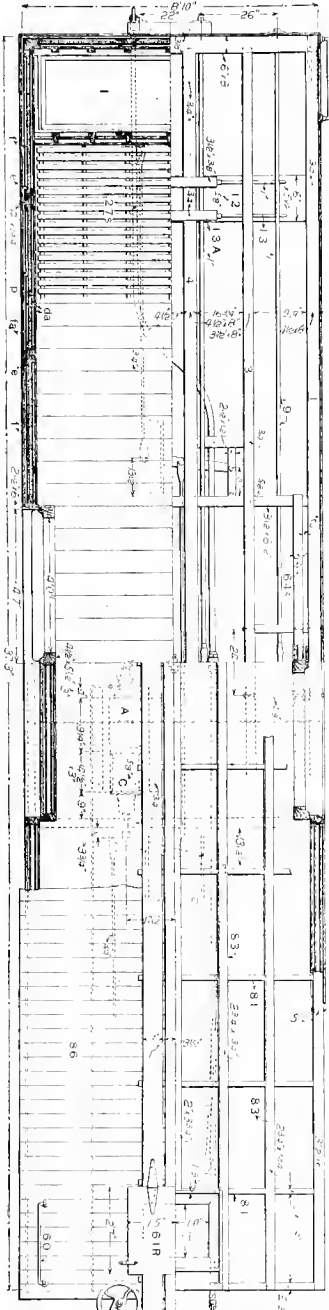

Fig. 281. Sectional Plan Showing Framing.

REFRIGERATOR-CAR BODY FOR FREIGHT. SOUTHERN PACIFIC COMPANY.
Length, 37 ft., 3 in. Capacity, 50,000 lbs. Weight, 40,000 lbs.
Contra Patents. (General view is shown in Fig. 12.)

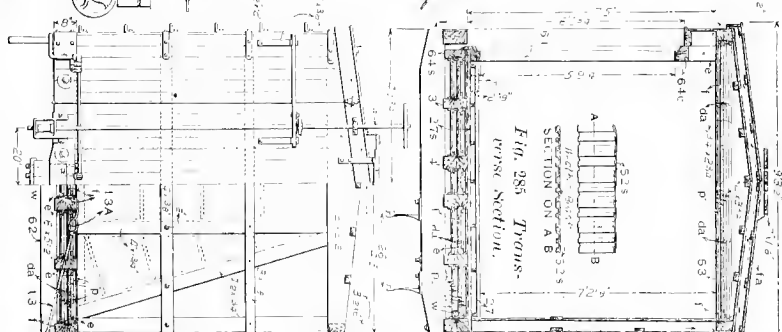

Fig. 285. Truss-section.

Fig. 286. End Elevation.

Names of Parts Special to Figs. 283-286.

- | | | |
|------------------------------------|-----------------------------|---------------------------------|
| 1. Side-sill. | 36. Sill-and-plate Rod. | 64c. Door-lintel. |
| 4. Center-sill. | 52s. Fluted Weather-boards. | 64s. Door Sub-sill. |
| 13. Body-bolster Truss-rod. | 53. Ceiling. | 81. Curstie. |
| 13a. Body-bolster Truss-rod Strap. | 54s. Belt-rail. | 88. Running-board Extension. |
| 26. Draft-timbers. | 61. Door. | A. Auxiliary Reservoir. |
| 27. Floor. | 61o. Open Door. | C. Brake-cylinder. |
| 27s. Slatted-floor. | 61r. Roof-door. | T. Triple-valve. |
| | | e. Skeleton Frame to Hold Felt. |
| | | f. Felt. |
| | | p. Paper. |
| | | da. Dead Air-space. |
| | | fa. Fyre Abr-space. |
| | | w. Wood-lining. |

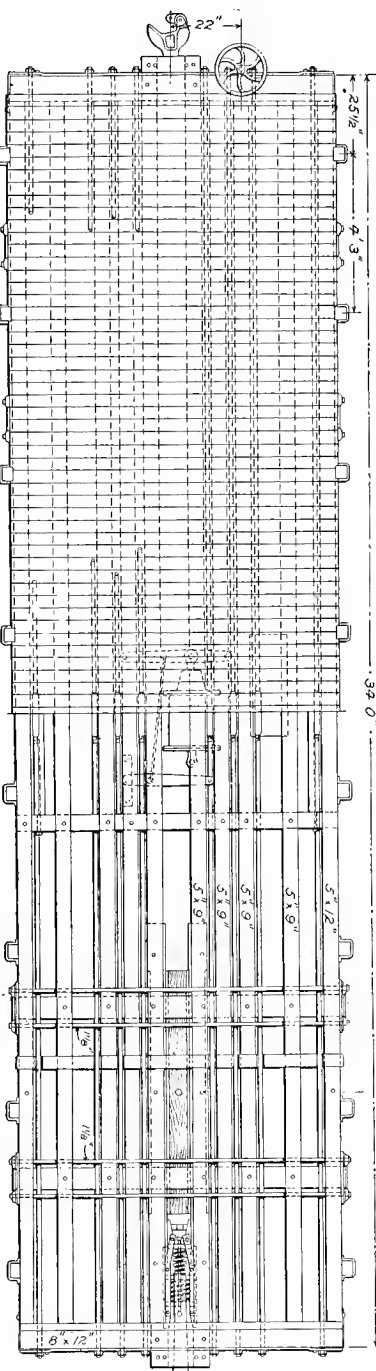
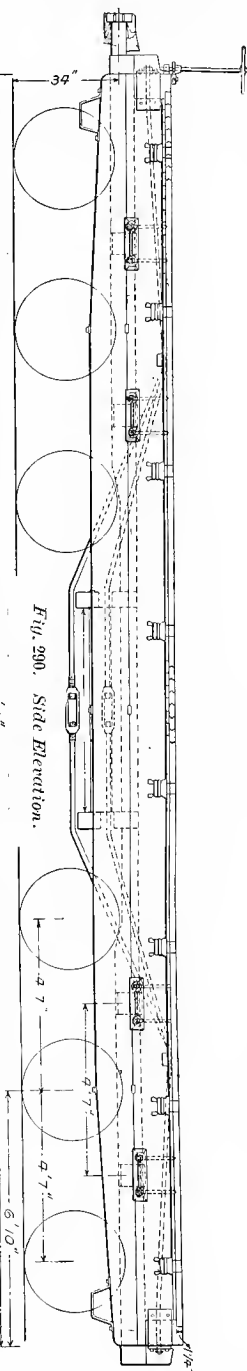

Fig. 291. Plan showing Floor and Underframing. FLAT-CAR BODY, CHICAGO & NORTH WESTERN RAILWAY. (Trucks are shown infra.) Capacity, 107,000 lb.

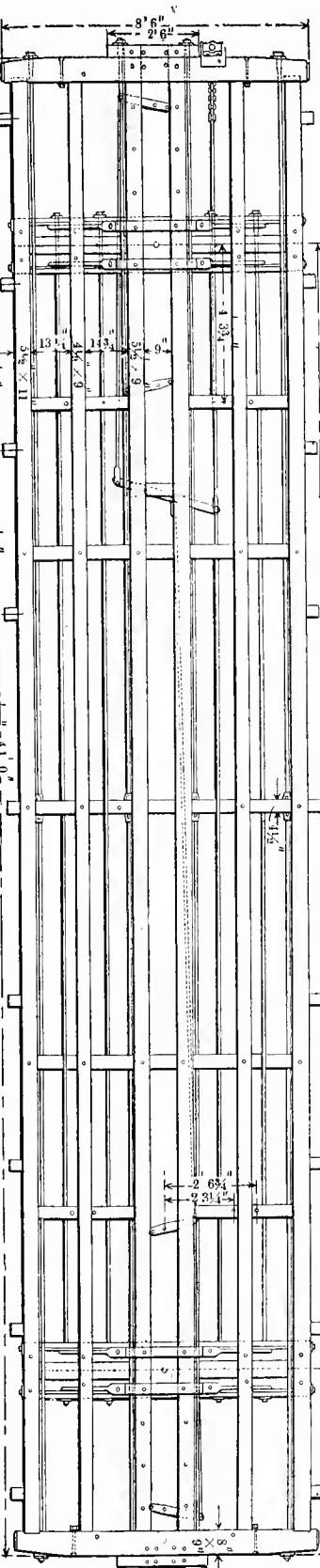
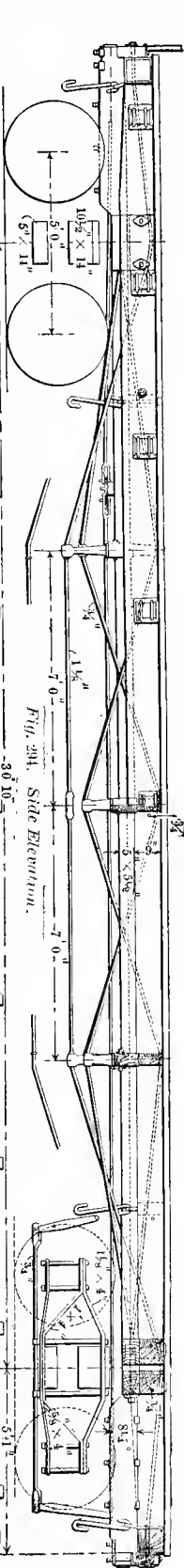
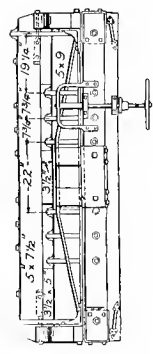

Fig. 293. Plan of Underframe. FLAT-CAR BODY, FOR LONG TIMBERS. ENSIGN MANUFACTURING COMPANY. Length, 41 ft. Capacity, 60,000 lbs. Weight, 23,700 lbs. Inverted King and Queen Post Trussing, with Counterstruts to prevent Buckling. (General view is shown in Fig. 19.)



End View.

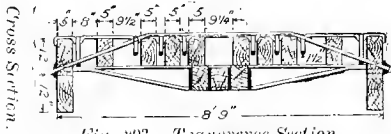

Fig. 293. Transverse Section.

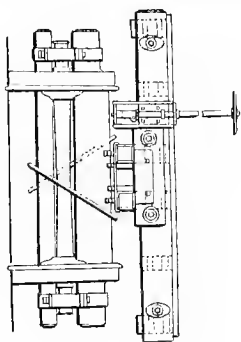

Fig. 296. End Elevation. FLAT-CAR BODY. Same as Fig. 293.

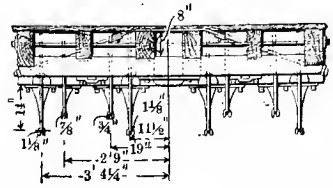
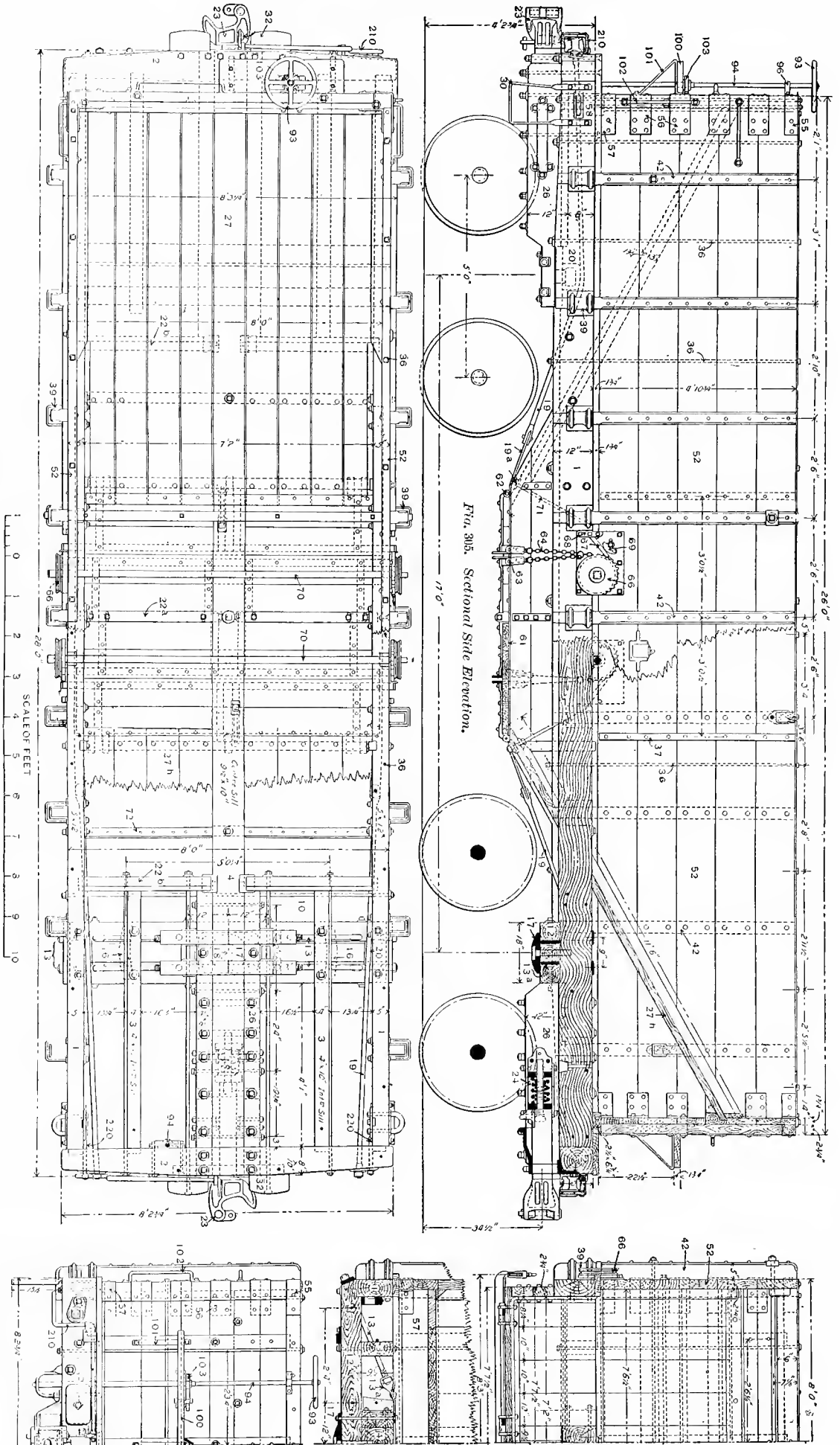

Fig. 297. Transverse Section.

Numbers Refer to List of Names with Figs. 298-304.



Numbers Refer to List of Names of Parts with Figs. 298-304.

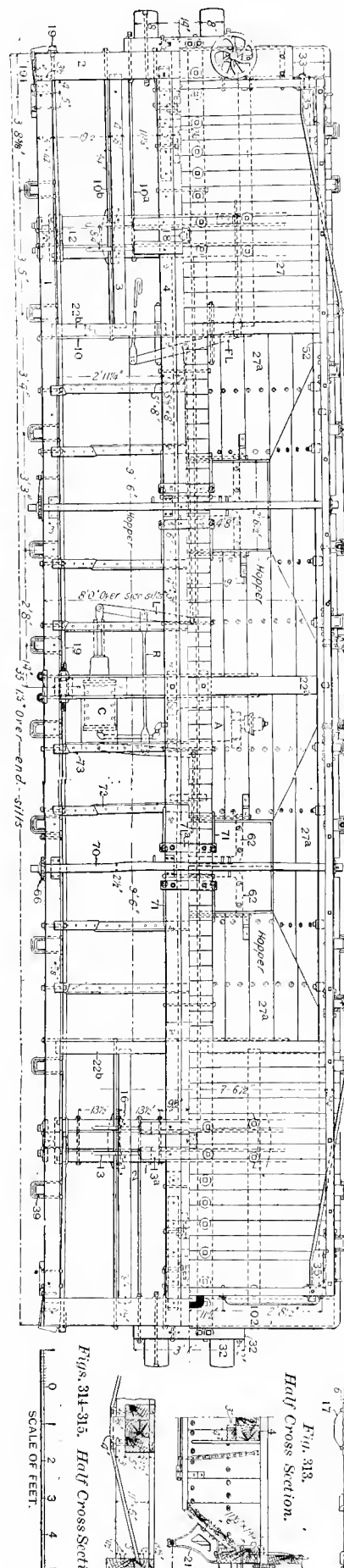
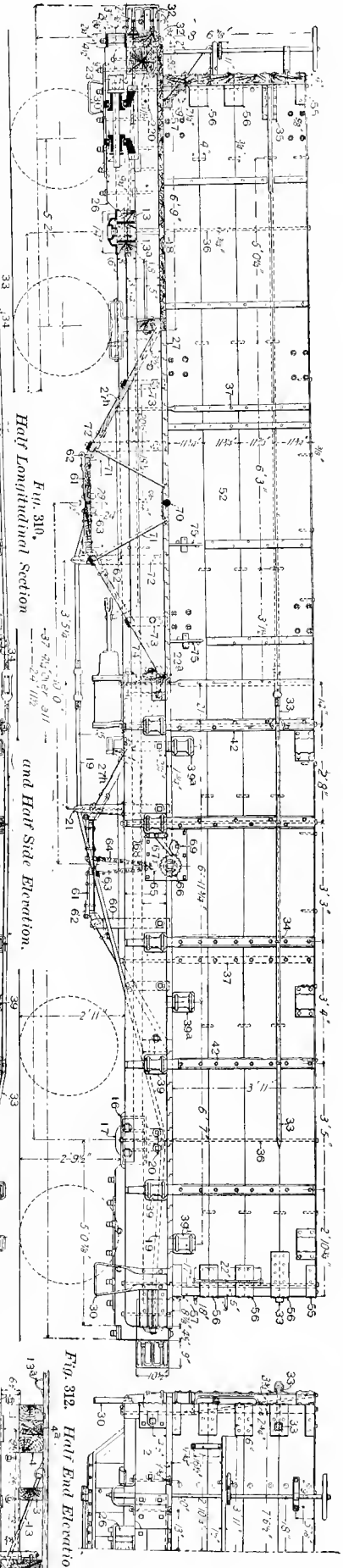

Fig. 311. Sectional Plan.
GONDOLA-CAR BODY, TWIN-HOPPER, FOR COAL.

NAMES OF PARTS OF ORE CAR. Figs. 325-327.

- | | | | |
|---------------------------|------------------------------|---------------------------------------|-------------------------------|
| 1. Side-sill. | C. Cross-timber Hopper-ends. | L. Side-bearing Timbers. | S. Inclined Struts for Floor. |
| 2. End-sill. | D. Cross-beam on Sills. | M. Supports for Side-bearing Timbers. | U. Deck-planks. |
| 3. Intermediate-sill. | E. Upper Cross-beam. | N. Side Hopper-plank. | V. Drop-door Planks. |
| 4A. Short Center-sill. | F. End-posts. | O. Bench-ends. | W. Side-wall. |
| 26. Draft-timber. | G. Corner-posts. | P. Bench-egg Posts. | X. End-wall. |
| 32. Buffer-block. | H. Center-posts. | Q. Side Chute-plank. | Y. Deck-beams. |
| A. Center Cross-beam. | J. Side-posts. | R. End Chute-plank. | |
| B. Center Cross-beam Cap. | K. End-braces. | | |

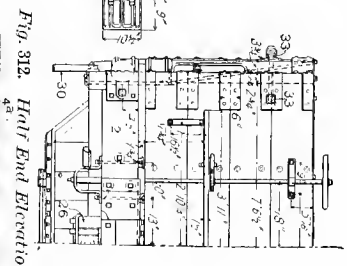
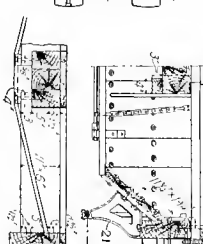
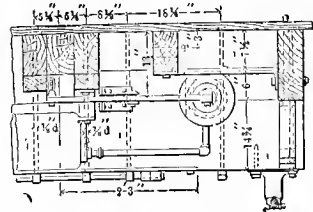
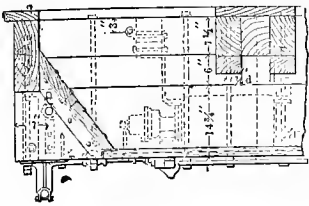

Fig. 313. Half Cross Section.



Figs. 314-315. Half Cross Sections.
SCALE OF FEET.



Figs. 318 and 319.
Part Cross Section.

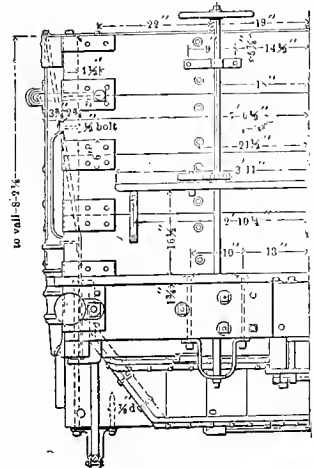

Fig. 320. Half End Elevation.
TWIN-HOPPER GONDOLA-CAR BODY.
N. Y., L. E. & W. R. R.

NAMES OF PARTS OF STONE CAR. Figs. 328-331.

- | | |
|----------------------------------|---|
| 1a. Side-sill. | 112. Transverse Rising-timber. |
| 2. End-sill. | 125. Side-door Hinge. |
| 3. Intermediate-sill. | 131. Side-door Unlocking-lever. |
| 4. Center-sill. | 131b. Unlocking-lever Bar. |
| 12. Body-bolster. | 131c. Side-door Catch. |
| 19. Body Truss-rod. | 131f. Side-door Unlocking-lever-bar Spring. |
| 22. Cross-tie-timber. | 137. End-girth or Rail. |
| 32. Buffer-beam. | 135. Inclined Floor. |
| 42. Post. | 136. Side-rail. |
| 110. Longitudinal Rising-timber. | 153. Inclined-floor Joist. |
| 111. Vertical Post or Strut. | |
| 111a. Outer Post or Strut. | |

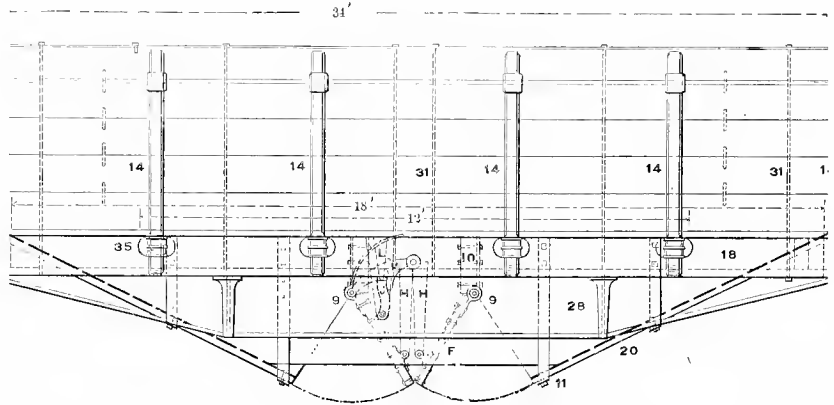

Fig. 324a. Side Elevation.

KING'S DOOR FOR HOPPER-BOTTOM CARS.

NAMES OF PARTS. Fig. 324a.

- | | |
|--|---|
| 9. Door Hinge. | 31. Sill-and-plank Rod. |
| 10. Cross-tie-timbers to which Doors are hung. | 35. Stake-pocket. |
| 11. Hopper Supporting-strap. | F. Door. |
| 14. Stake. | HH. Toggle-arms. |
| 18. Side-sill. | J. Rocking-lever. |
| 20. Hopper-floor. | K. Toggle-joint Lever with Arm, which works on arc of circle. |
| 28. Hopper-siding. | L. Lever-shaft Bracket. |

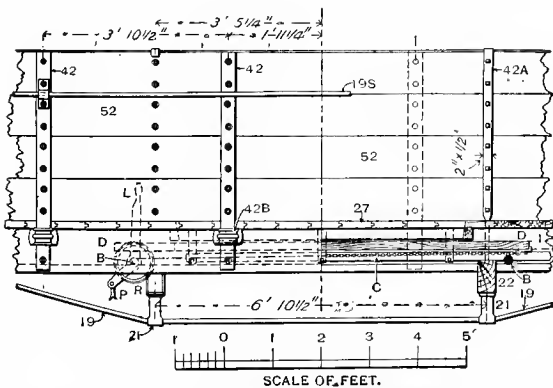

Fig. 321. Part Sectional Side Elevation.

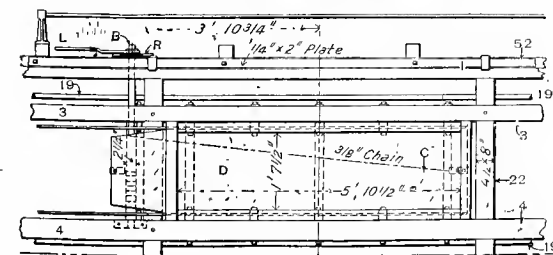

Fig. 322. Part Plan of Door.
SLIDE DOOR AND SIDE TRUSSING OF CANADA GONDOLA CAR.

NAMES OF PARTS. Figs. 321-324.

- | | |
|---------------------------|------------------------------------|
| 1. Side-sill. | 42a. Side-plank Strap. |
| 3. Intermediate-sill. | 52. Side Planking. |
| 4. Center-sill. | B. Chain Winding-shaft. |
| 19. Body Truss-rod. | C. Chain. |
| 19s. Side Body-truss-rod. | D. Slide door. |
| 21. Truss-rod Bearing. | R. Ratchet-wheel. |
| 22. Cross-tie-timber. | P. Pawl for Ratchet-wheel. |
| 27. Floor. | L. Lever to Operate Winding-shaft. |
| 42. Stake. | |
| 42b. Stake-pocket. | |

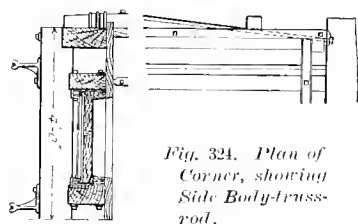

Fig. 323. Cross Section of Door.

Fig. 324. Plan of Corner, showing Side Body-truss-rod.

Letters Refer to List of Names with Figs. 310-315.

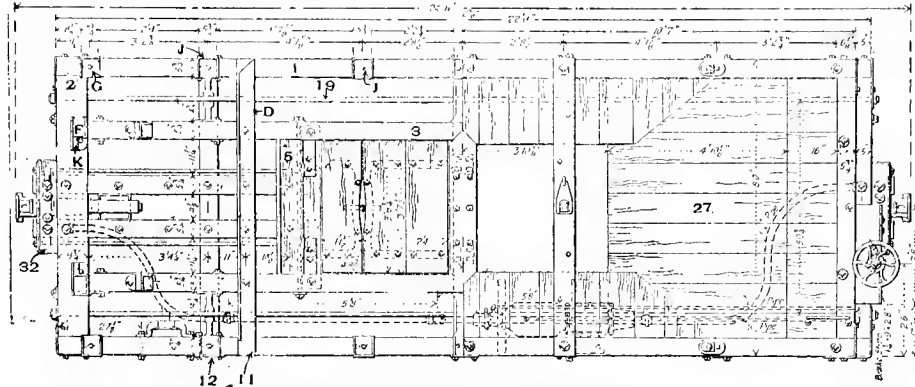
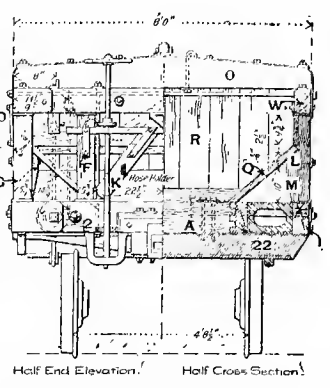
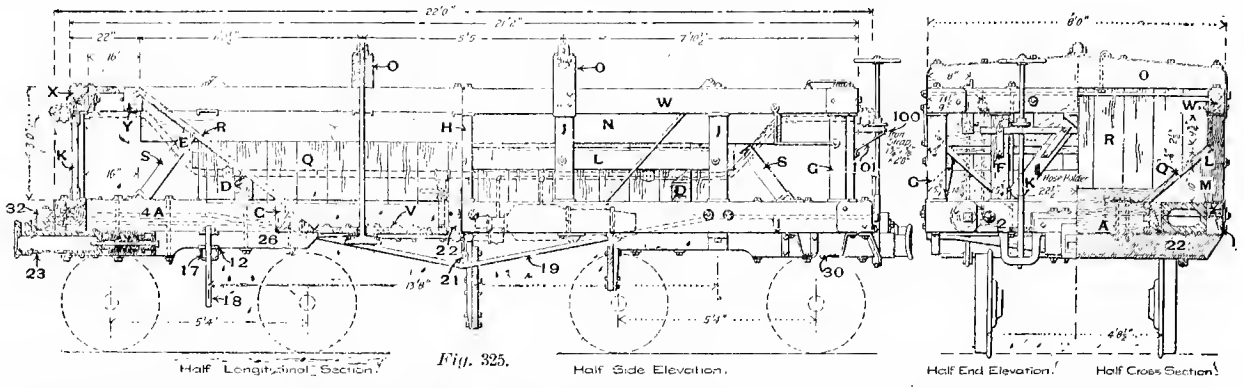

Fig. 326. Plan of Framing and Hopper.
ORE-CAR BODY. DULUTH & IRON RANGE RAILROAD.
Length, 22 ft. Capacity, 48,000 lbs.

Numbers Refer to List of Names on Preceding Page.

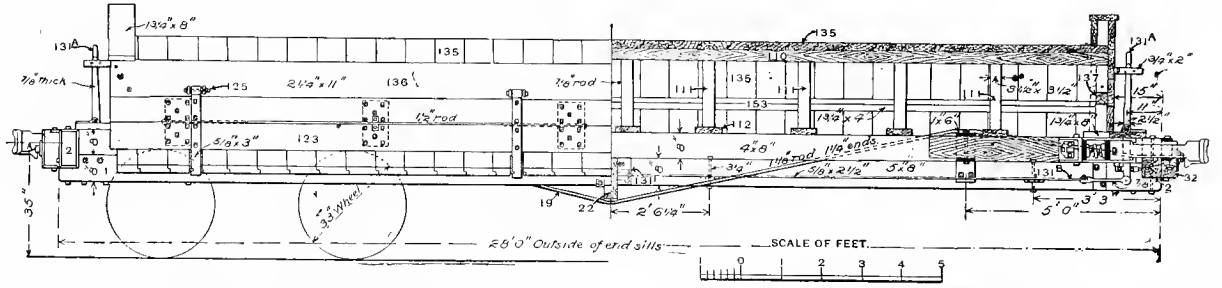

Fig. 328. Half Side Elevation. Half Longitudinal Section.

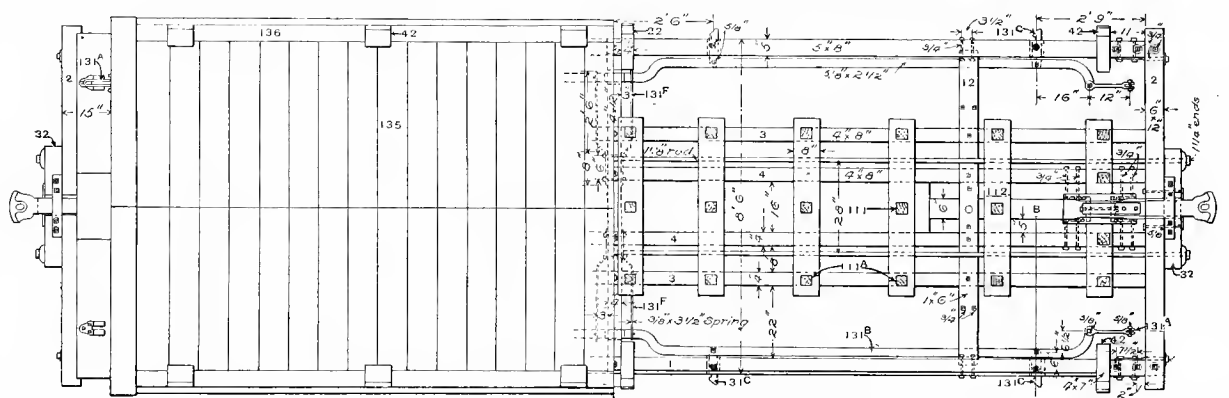

Fig. 329. Half Plan of Car and Half Plan of Underframe.

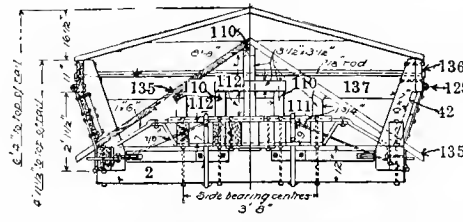

Fig. 330. Transverse Sections.

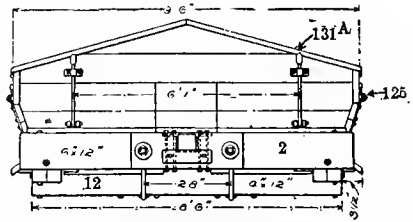

Fig. 331. End Elevation.

SIDE-DUMP-CAR BODY FOR STONE. CHESAPEAKE & OHIO RAILWAY.

Numbers Refer to List of Names on Following Page.

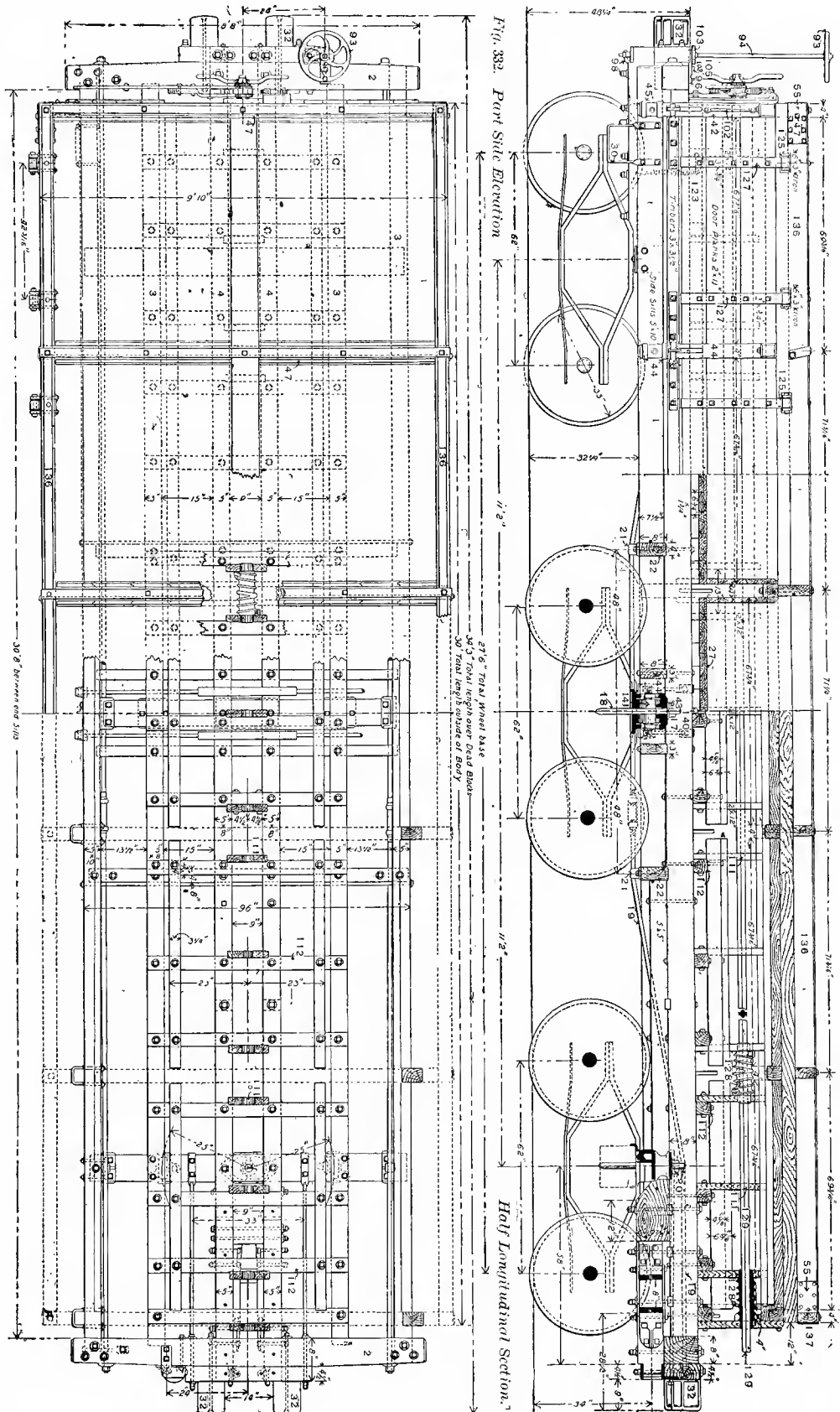

Fig. 333. Half Plan of Floor and Half Plan of Underframe.

SIDE-DUMP CAR BODY, FOR CRR. NEW YORK LAKE ERIE & WESTERN RAILROAD.

Twelve-wheel. Length, 30 ft. Capacity, 80,000 lbs.

Numbers Refer to List of Names on Preceding Page.

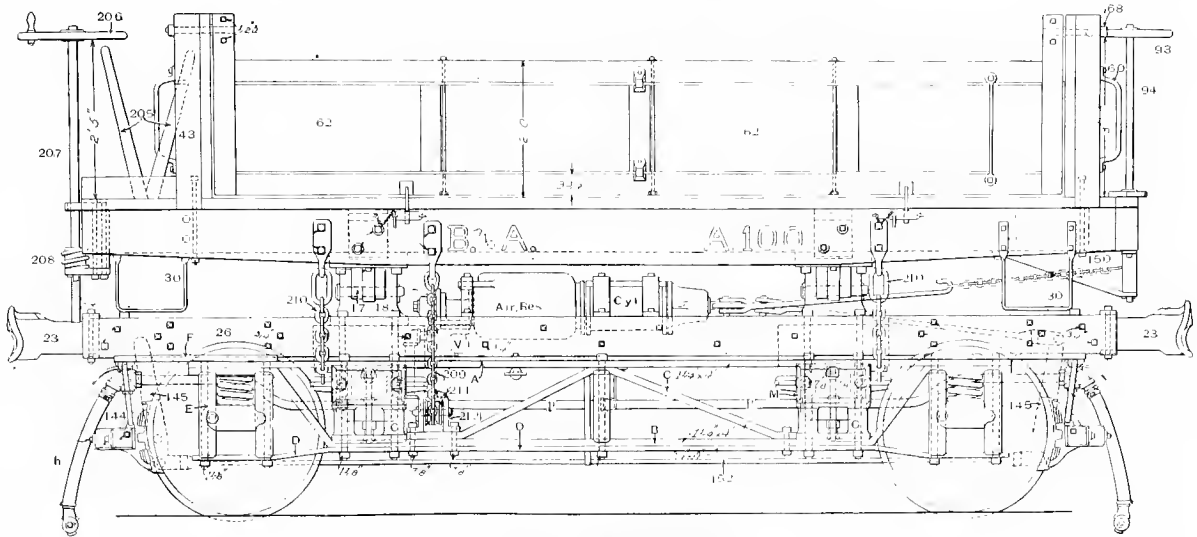

Fig. 336. Side Elevation.

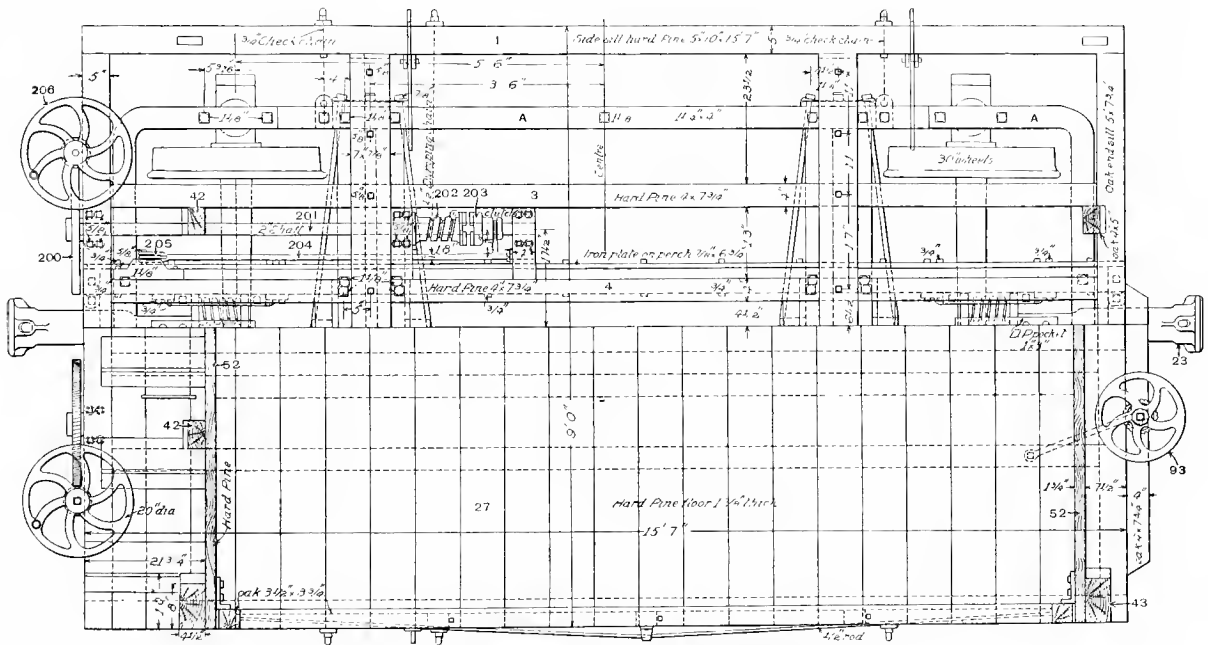

Fig. 337. Plan showing Floor and Underframe.

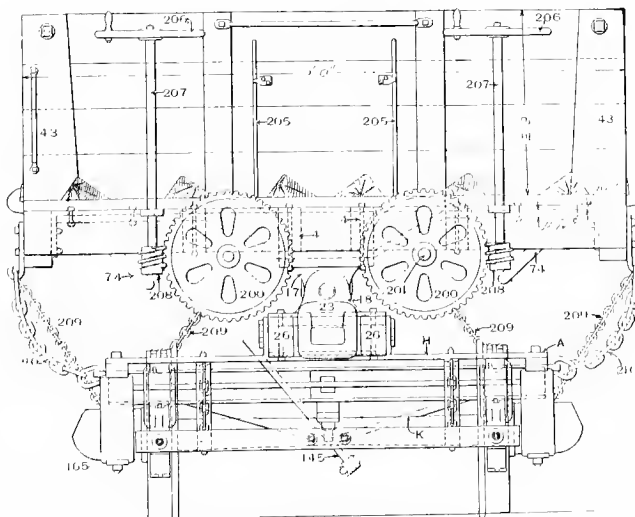

Fig. 338. End Elevation.

SIDE-DUMP CAR, BOSTON & ALBANY RAILROAD.
 (Dumped by Chain wound around a Shaft by Worm and Wheel.)

Numbers Refer to List of Names of Parts on this and the Opposite Page.

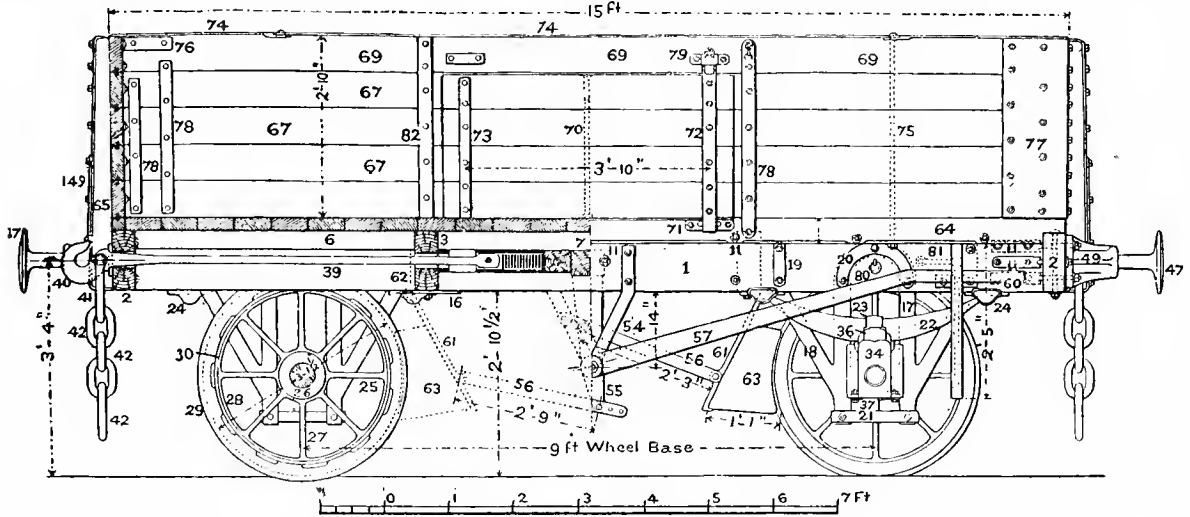

Fig. 348. Half Longitudinal Section and Half Side Elevation.

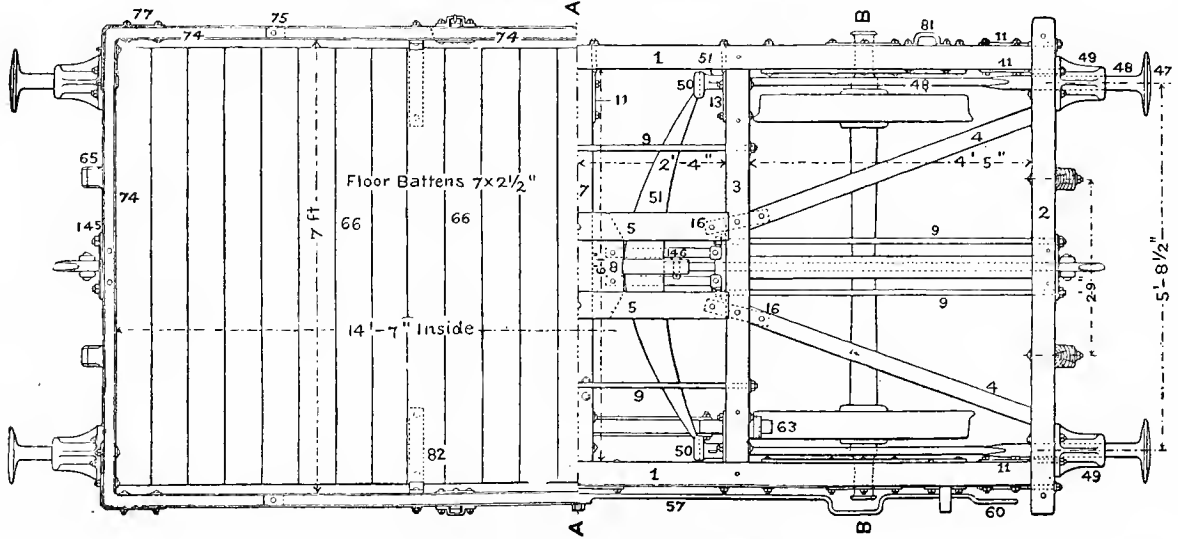

Fig. 349. Plan of Floor and Underframe.

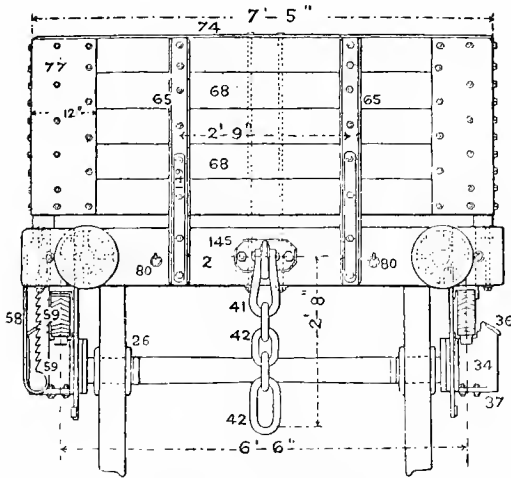

Fig. 350. End Elevation.

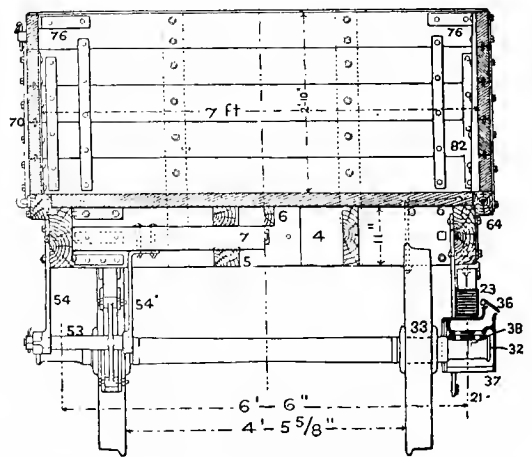

Fig. 351. Transverse Section.

ENGLISH OPEN " GOODS WAGON.

Length, 15 ft. Capacity, 18,000 lbs. Weight, 10,700 lbs.

NAMES IN USE IN ENGLAND FOR PARTS OF GOODS WAGON. Figs. 348-351.

- | | | | |
|---|---------------------------------------|-------------------------------------|--|
| 1. Solebar. | 7. Brake-shaft Cross-bearer, | 16. Spuler-plate (plain), or | 21. Axle-guard Keep, |
| 2. Headlock or Buffer-beam. | or Center Crossbar. | Underframe Plate. | Horn-stay, or Bridle. |
| 3. Cross-Bearer, Cross-bar or Transome. | 8. Buffing-spring Bed, or Back-Chock. | 17. Axle-guard-crown. | 22. Bearing-spring. |
| 4. Diagonal. | 9. Longitudinal Tie-rod. | 18. Axle-guard Wing. | 23. Bearing-spring Buckle, or Hoop. |
| 5. Middle Longitudinal. | 10. Transverse Tie-rod. | 17 and 18. Axle-guard, "W" Pattern. | 24. Bearing-spring Shoe. |
| 6. End Half-longitudinal, | 11. Strap-bolt. | 19. Axle-guard Wing-washer. | 25. Wheel (Solid Wrought-iron Single-spoke). |
| | | 20. Axle-guard Crown-washer. | |

(Continued.)

NAMES IN USE IN ENGLAND FOR PARTS OF A GOODS WAGON. Figs. 348-351.

(Continued.)

- | | | | |
|--|--|---|---|
| 26. Boss, or Nave. | 48. Buffer-rod. | 60. Brake-lever Handle. | 74. Coping or Capping-iron. |
| 27. Spoke. | 49. Buffer-rod Guide, or Buffer-Block. | 61. Brake-hanger, or Brake-Block Hanger. | 75. Through Body-bolt. |
| 28. Rim. | 50. Buffer-rod Shoe. | 62. Brake-hanger Bracket. | 76. Inside Body Corner-knee. |
| 29. Tire. | 51. Plate or Laminated Buffing and Draw-spring. | 63. Brake-block (Wood). | 77. Outside Corner-plate. |
| 26, 27 and 28. Wheel-center, or Skeleton. | 52. Auxiliary Draw-spring (Rubber). | 64. Crib-rail, Rocker-rail, or Side-rail. | 78. Strap-washer, or Washer-plate. |
| 30. Key-ring Tire-fastening. | 53. Brake-shaft, or Weigh-bar. | 65. End-stanchion, or End-muntin. | 79. Falling-door Latch, consisting of Door Fastening, Staple, Cotter and Chain. |
| 31. Journal. | 54. Brake-shaft Hanger (V-Pattern). | 66. Floor-board, or Floor-batten. | 80. Sheet-ring and Staple. |
| 32. Collar of Journal. | 54'. Brake-shaft Hanger (Plate Pattern). | 67. Side-board, or Side-sheeting. | 81. Horse-hook, or Towing-hook. |
| 33. Wheel-seat. | 55. Brake-shaft Arm, or Brake Double-lever. | 68. End-board, or End-sheeting. | 82. Body-knee. |
| 34. Grease Axle-box. | 56. Brake-rod, or Brake Push-rod. | 69. Continuous Topside. | 145. Dowel-hook Washer, or Drawbar Front-plate. |
| 35. Grease-chamber. | 57. Brake-lever, or Long Brake-lever. | 70. Falling Door, or Flap Door. | 146. Draw-spring Cradle plate. |
| 36. Axle-box Cover, or Lid. | 58. Brake-lever Guard. | 71. Strap-hinge, or Door-hinge Joint. | |
| 37. Axle-box Keep. | 59. Brake-lever Ratchet. (58 and 59 are also termed Brake-lever Rack.) | 72. Hinge-plate, or Door-hinge. | |
| 38. Axle-box Bearing, or Brass. | | 73. Hinge-plate Washer, or Door-hinge Washer-plate. | |
| 39. Drawbar. | | | |
| 40. Draw-hook. | | | |
| 41. Coupling-shackle. | | | |
| 42. Coupling-link. | | | |
| 41 and 42. Wagon-coupling, or Draw-chain, consisting of Shackle, Shackle-pin and Links | | | |
| 47. Buffer-head. | | | |

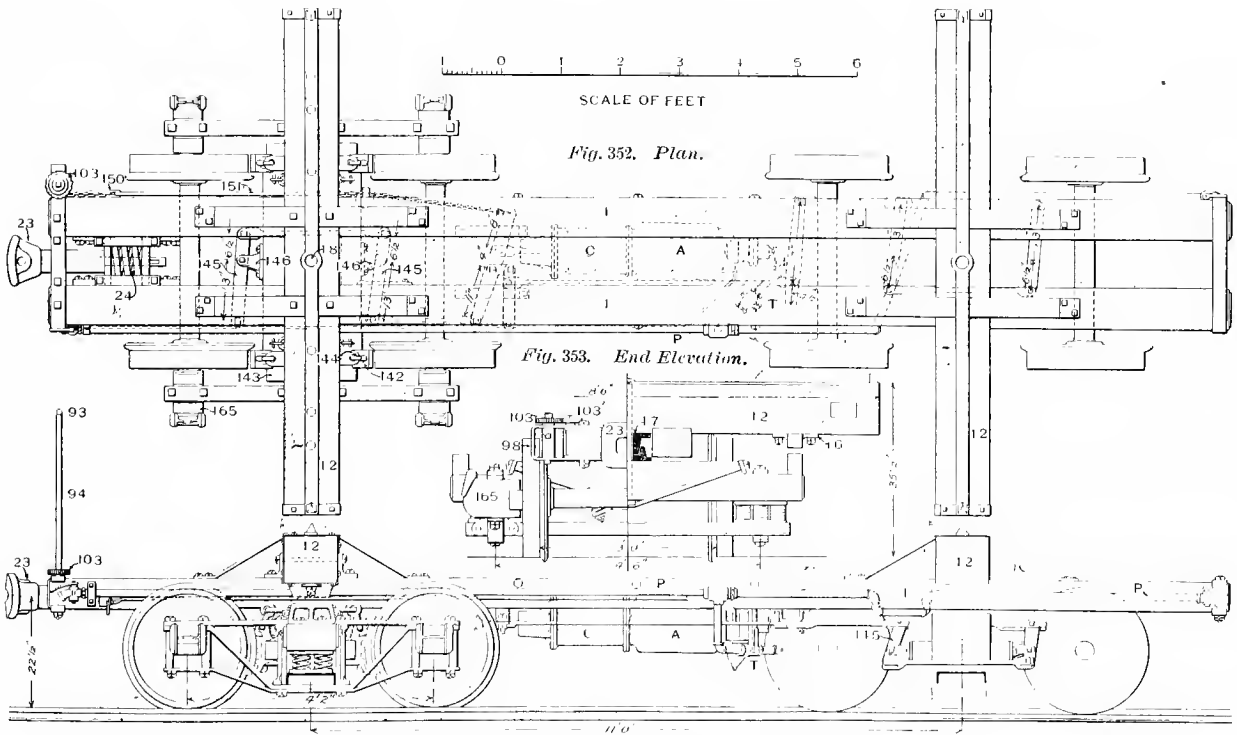

Fig. 354. Side Elevation.
 LOGGING CAR. RUSSELL WHEEL & FOUNDRY COMPANY.
 (General View is Shown in Fig. 36.)

NAMES OF PARTS OF LOGGING CAR. Figs. 352-354.

- | | | | |
|------------------------|---------------------------|---------------------------|--|
| 1. Sill. | 24. Draft-spring. | 142. Brake-head. | PARTS OF AIR-BRAKE.
A. Auxiliary Reservoir.
C. Brake-cylinder.
P. Train-pipe. |
| 12. Bolster. | 93. Brake-shaft Handle. | 143. Brake-beam. | |
| 16. Body Side-bearing. | 94. Brake shaft. | 144. Brake-hanger. | |
| 17. Center-plate. | 98. Brake-shaft Step. | 145. Brake-lever. | |
| 18. King-bolt. | 103. Brake Ratchet-wheel. | 146. Brake-lever Fulcrum. | |
| 23. Drawbar. | 103'. Brake-pawl. | 165. Journal-box. | |

Numbers Refer to List of Names with Figs. 367-368.

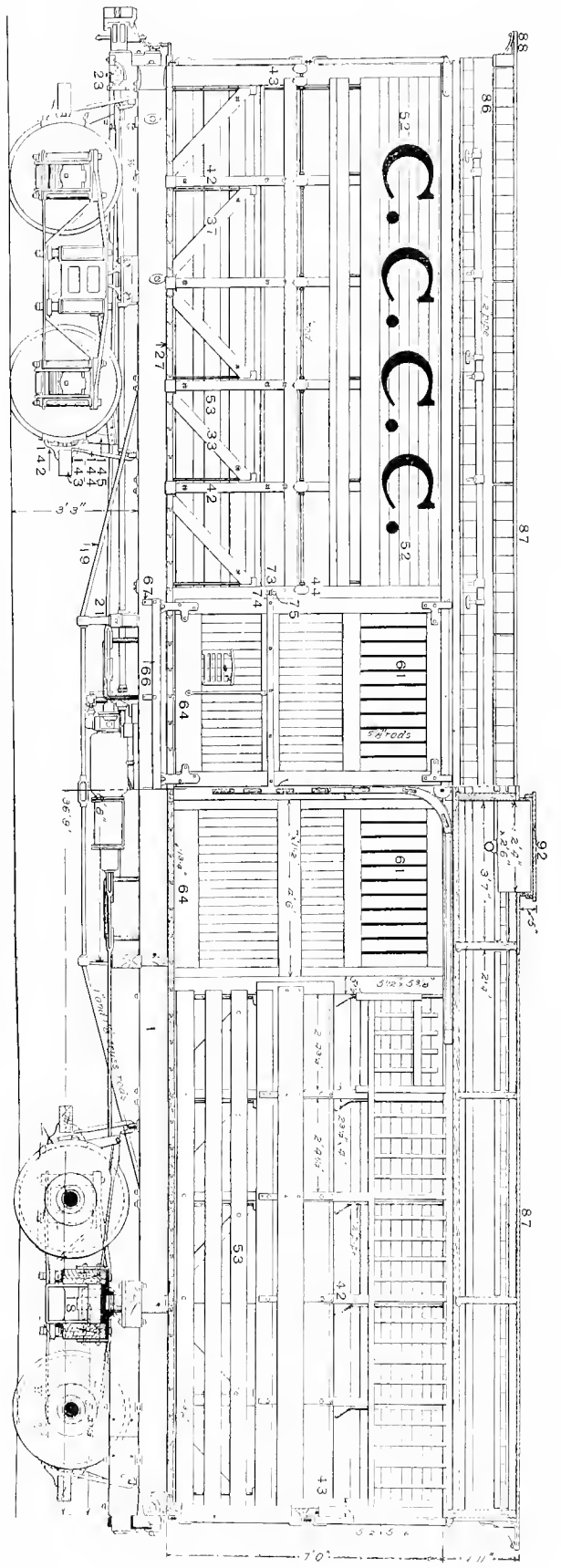

Fig. 359. Half Side Elevation and Half Longitudinal Section.

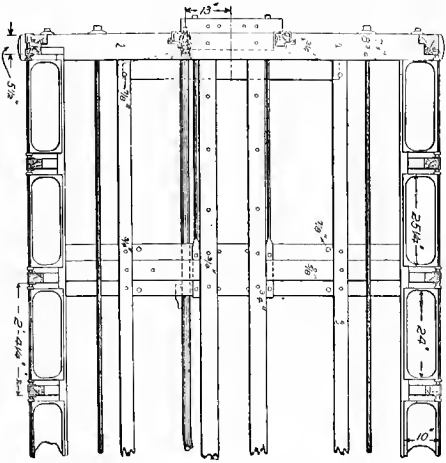

Fig. 360. Port Plan of Underframe.

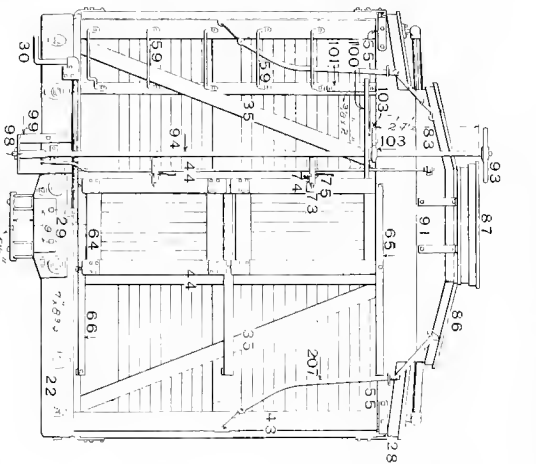
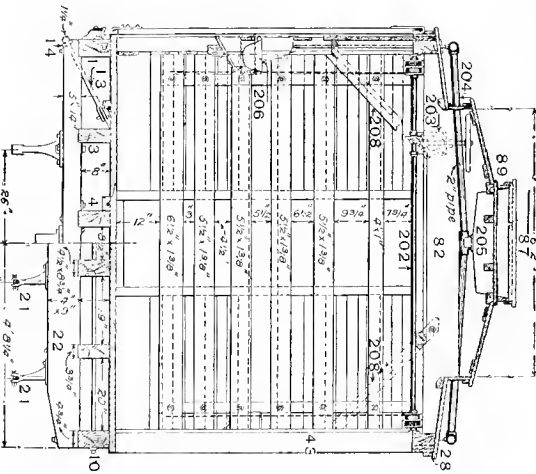

Fig. 361. End Elevation.



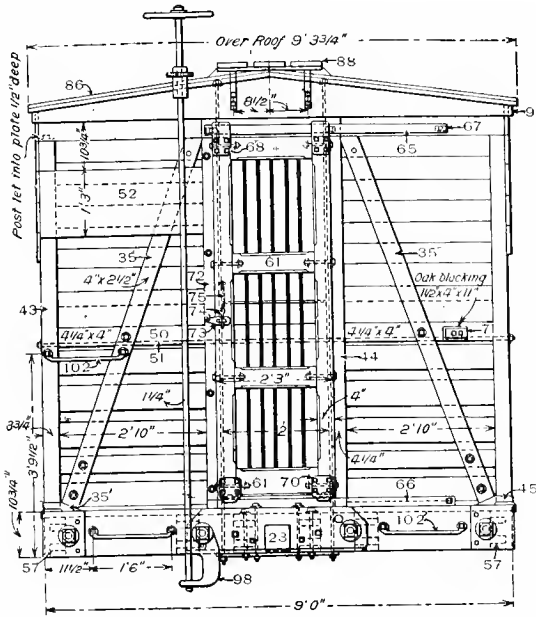

Fig. 367. End Elevation.

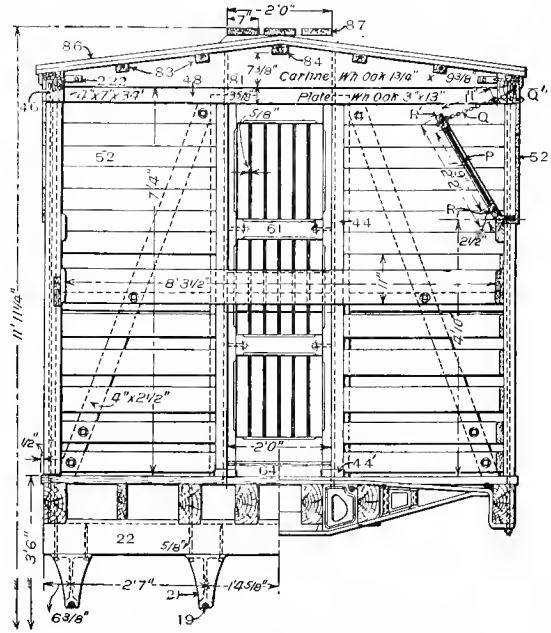

Fig. 368. Transverse Half Sections.

STOCK-CAR BODY. CHICAGO, BURLINGTON & QUINCY RAILROAD.

NAMES OF PARTS OF STOCK-CAR BODIES, Figs. 355-372.

- | | | |
|---|---------------------------------|--------------------------------------|
| 1. Side-sill. | 39. Brace-pocket. | 74. Door-pin. |
| 2. End-sill. | 40. Right-hand Brace-pocket. | 75. Door-pin Chain. |
| 3. Intermediate-sill. | 41. Double Brace-pocket. | 77. Door-guard or Cattle Bar. |
| 3a. Outer Intermediate-sill. | 42. Post. | 78. Door-handle. |
| 4. Center-sill. | 42'. Post-pocket. | 81. Carline. |
| 9. Sill Knee-Iron. | 43. Corner-post. | 82. (Same as 81.) |
| 10. Sill Tie-rod. | 44. Door-post. | 83. Purlin. |
| 12. Body-bolster. | 44'. Door-post Pocket. | 84. Ridge-pole. |
| 13. Body-bolster Truss-rod. | 45. Corner-post Pocket. | 86. Roof-boards. |
| 13a. Body-bolster Truss-rod Saddle. | 46. Plate. | 87. Running-board. |
| 14. Body-bolster Truss-rod Washer. | 47. Plate-rod. | 88. Running-board Extension. |
| 15. Body-bolster Truss-block. | 48. End-plate. | 89. Running-board Extension Bracket. |
| 16. Body Side-bearing. | 49. Girth. | 91. Eaves Facia-board. |
| 17. Body Center-plate. | 50. End-girth. | 93. Brake-wheel. |
| 18. King-bolt or Centre-pin. | 51. End-girth Tie-rod. | 94. Brake-shaft. |
| 19. Body Truss-rod. | 52. Sheathing. | 95. Horizontal Brake-shaft. |
| 20. Body Truss-rod Saddle. | 53. Inside-lining. | 96. Upper Brake-shaft Bearing. |
| 21. Body Truss-rod Bearing | 55. Outside Upper Corner-plate. | 98. Brake-shaft Step. |
| 22. Cross Tie-limber. | 55'. Inside Upper Corner plate. | 99. Brake-shaft Bracket. |
| 23. Drawbar. | 56. Middle Corner-plate. | 100. Brake-step. |
| 26. Draft-limbers. | 57. Lower Corner-plate. | 101. Brake-step Bracket. |
| 27. Floor. | 58. Roping-staple. | 102. Hand-hold. |
| 28. Upper-floor or Double-deck. | 59. Ladder-rombs. | 103. Brake Ratchet-wheel. |
| 30. Sill-step. | 60. Roof Grab-iron. | 105. Brake-shaft-chain Sheave. |
| 31. Sill-step Stay. | 61. Grated-door. | 178. Door Center-girth. |
| 32. Buffer-blocks. | 64. Door-sill. | 186. Key-blocks. |
| 32'. Buffer-beam. | 65. Top Door-track. | 190. Brake Hand-rail. |
| 33. Side Brace. | 66. Bottom Door-track. | 191. Push-pole Corner-plate. |
| 34'. Side Brace-rod. | 67. Door-track Bracket | 201. Drawbar Curry-iron. |
| 34b. Double Counter-brace-rod Plate-washer. | 68. Door-hanger. | 210. Uncoupling-lever. |
| 35. End Body-brace. | 69. Door-brace. | 212. Draw-gear Tie-rod. |
| 36. Sill-and-plate Rod. | 70. Door-shoe. | 220. Sill Strap-bolt. |
| 37. Counterbrace. | 71. Open-door Stop. | 221. (Same as 220.) |
| 37'. Counterbrace-rod. | 72. Closed-door Stop. | 222. Inside Upper Corner-plate. |
| | 73. Door-batsp. | |

Numbers Refer to List of Names on Preceding Page.

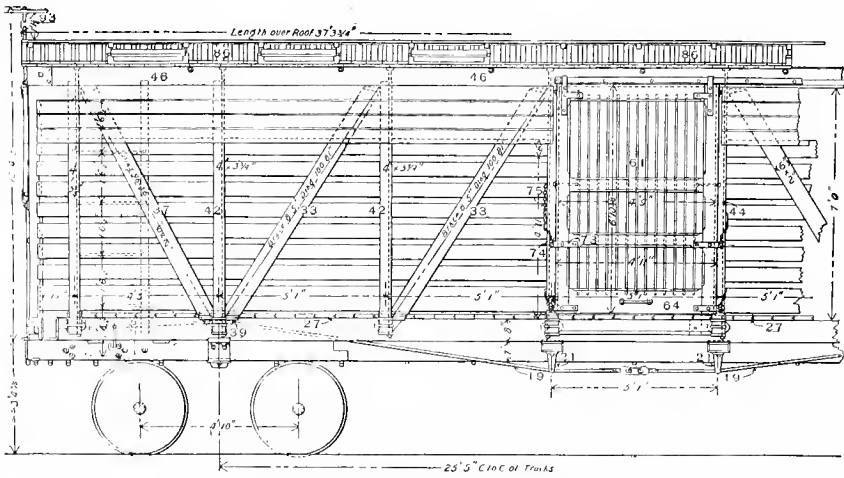

Fig. 369. Part Side Elevation.

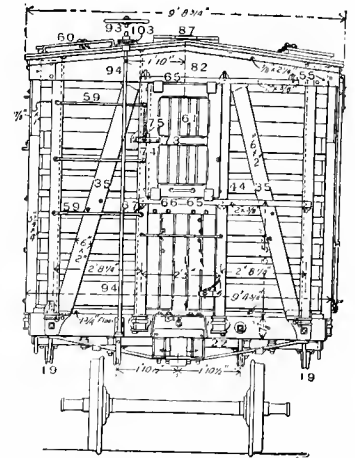

Fig. 370. End Elevation.

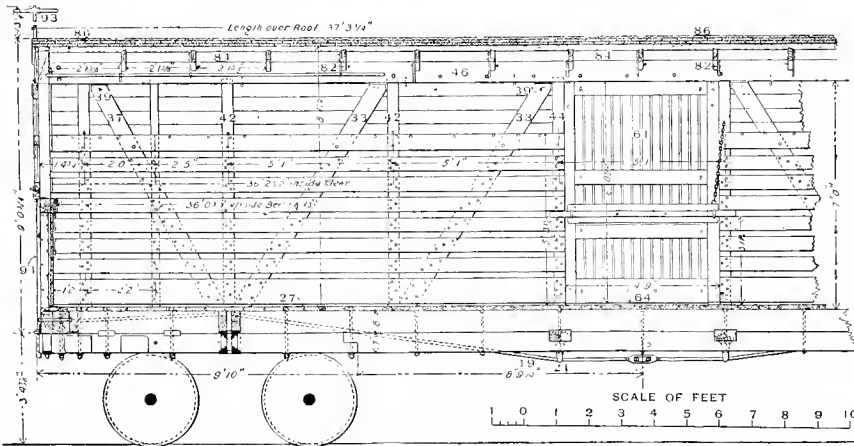

Fig. 371. Part Longitudinal Section.

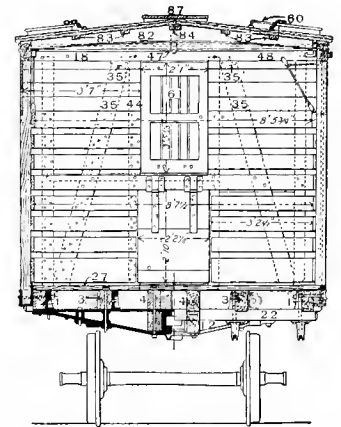

Fig. 372. Transverse Sections.

STOCK-CAR BODY. CHICAGO, MILWAUKEE & ST. PAUL RAILWAY.

NAMES OF PARTS OF TANK CAR. Figs. 373-379.

- | | |
|---------------------------------|--------------------------------------|
| 1. Sill. | 108. Tank-dome. |
| 2. End-sill. | 109. Dome-head. |
| 4. Center-sill. | 110. Man-hole. |
| 7. Floor-timber Distance-block. | 111. Man-hole Cover. |
| 11. Transverse Floor-timbers. | 112. Safety-valve. |
| 12. Body-bolster. | 113. Man-hole Cover-hinge. |
| 17. Body Center-plate. | 114. Tank-valve. |
| 19. Body Truss-rod. | 115. Tank-valve Seat or Tank-nozzle. |
| 20. Body Truss-rod Bearing. | 117. Tank-valve Rod. |
| 22. Cross Tie-timber. | 117a. Tank-valve Rod Screw. |
| 23. Draw-bar. | 117b. Tank-valve Rod Lever. |
| 26. Draw-timbers. | 117c. Tank-valve Rod Bracket. |
| 30. Sill-step. | 118. Tank-nozzle Cap. |
| 32. Dead-blocks. | 119. Running-board. |
| 32a. Buffer-beam. | 121. Hand-rail. |
| 93. Brake-wheel. | 122. Hand-rail Post. |
| 94. Brake-shaft. | B. Upper and Lower Filling-strips. |
| 96. Upper Brake-shaft Bearing. | C. Tank-slabbing. |
| 98. Brake-shaft Step. | D. Tank-saddles. |
| 102. Grab-iron or Hand-hold. | E. Tank Head-block. |
| 106. Tank, for Tank-car. | F. Tank-band Tie-rod. |
| 106'. Tank-head. | |
| 107. Tank-band. | |

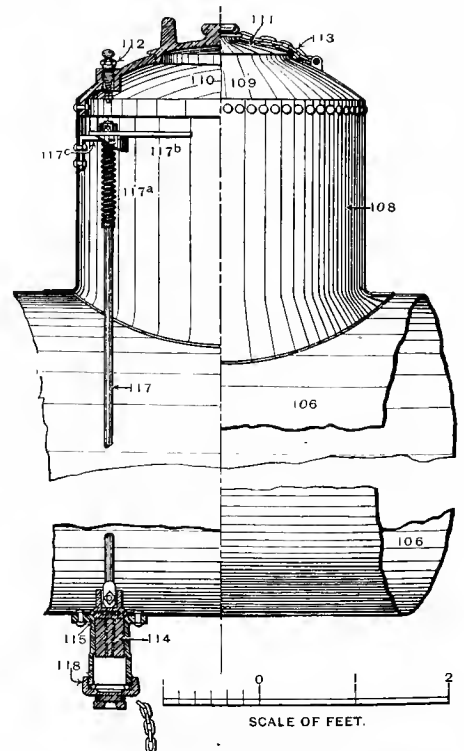

Fig. 373. Sectional Elevation of Tank, Dome and Valve.

Numbers Refer to List of Names on Opposite Page.

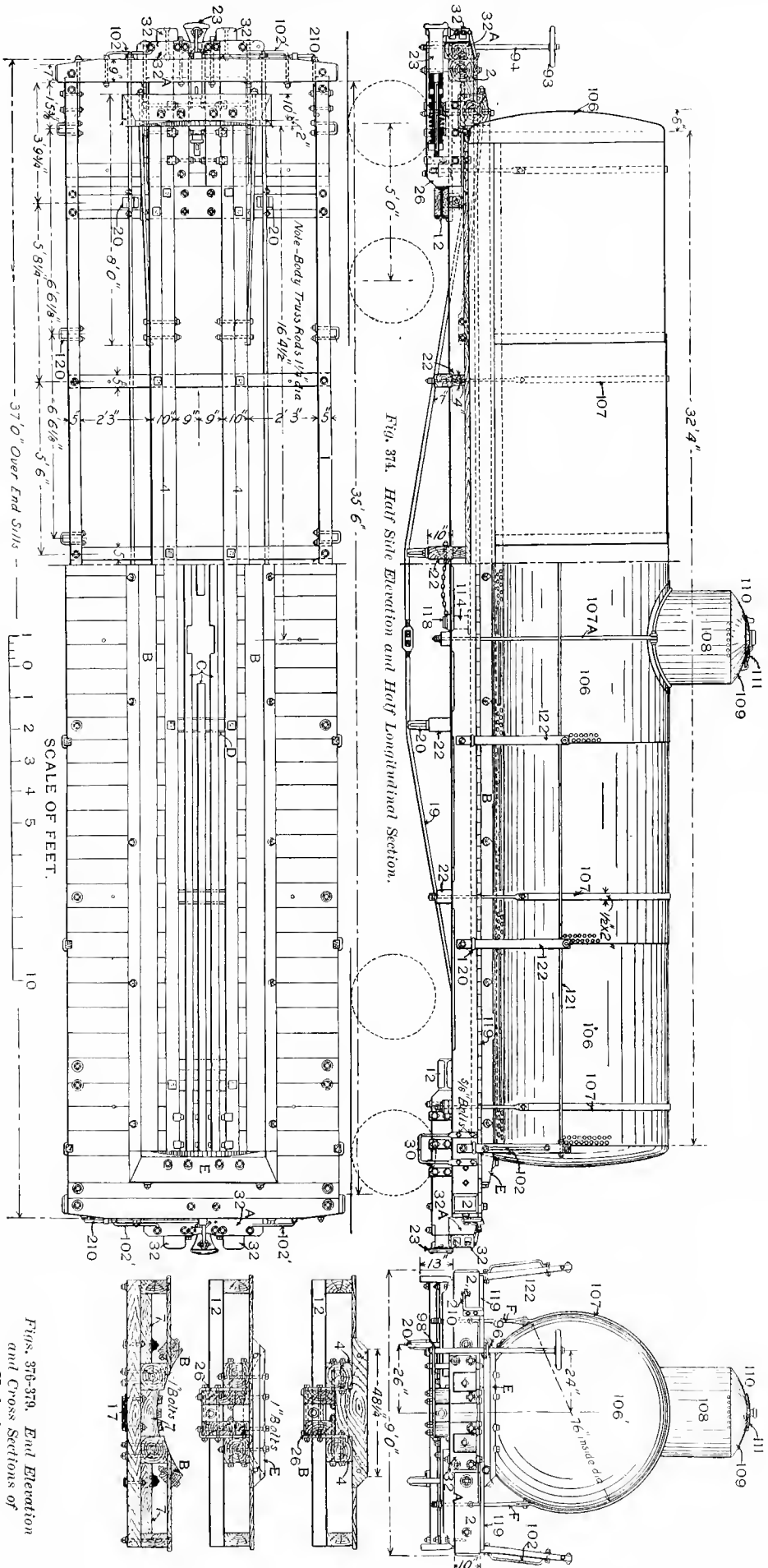

Fig. 375. Plan Showing Underframing, Floor and Tank Bed.

TANK-CAR BODY. UNION TANK LINE.
(General views are shown in Figs. 38-49.)

SCALE OF FEET.

Figs. 376-379. End Elevation and Cross Sections of Underframing.

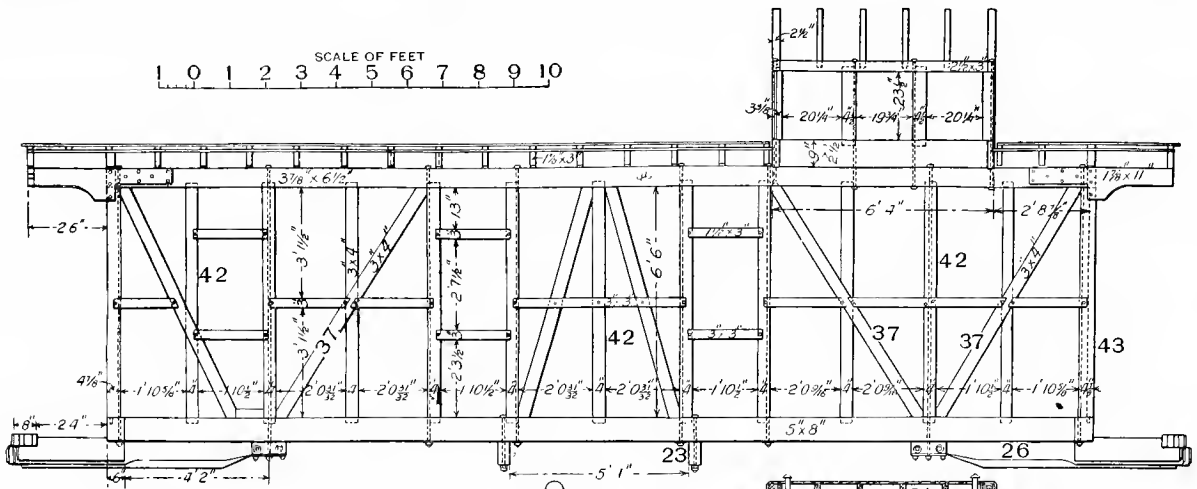

Fig. 380. Side Elevation of Frame.

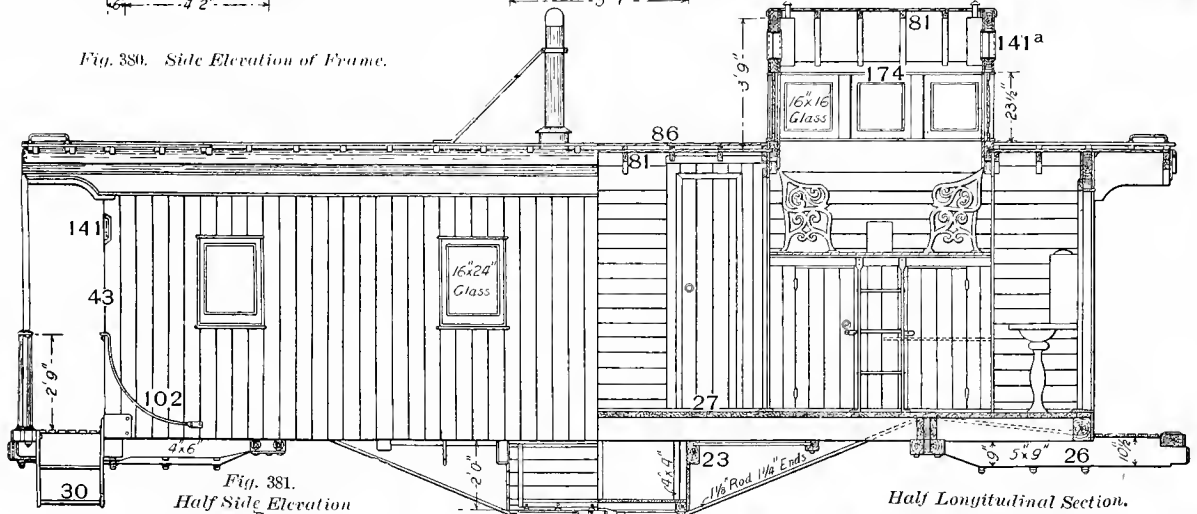

Fig. 381. Half Side Elevation

Half Longitudinal Section.

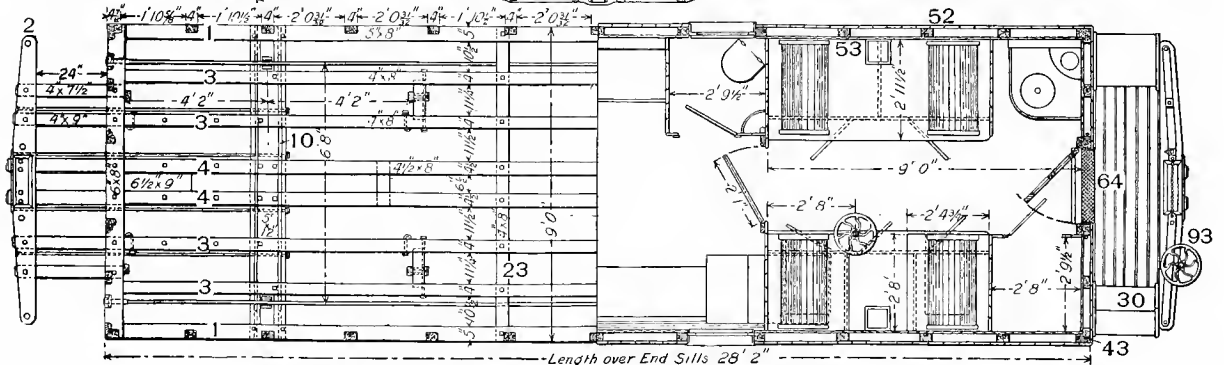

Fig. 382. Half Plan of Underframe and Half Plan of Floor.

NAMES OF PARTS. Figs. 380-384.

1. Side-sill.
3. Intermediate-sill.
4. Center-sill.
10. Body-holster.
23. Cross Tie-timber.
26. Draft-timber.
27. Floor.
30. Platform-step.
37. Brace.
42. Post.
43. Corner Post.
46. Plate.
52. Sheathing.
53. Lining.
64. Door-sill.
81. Carline.
86. Roof.
141. Signal-lamp Bracket.
- 141a. Lookout Signal-lamp.
174. Lookout.
102. Hand-hold.

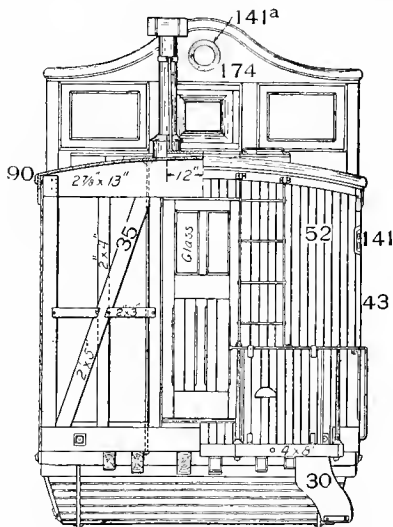

Fig. 383. Transverse Sections of Framing and Car Body.

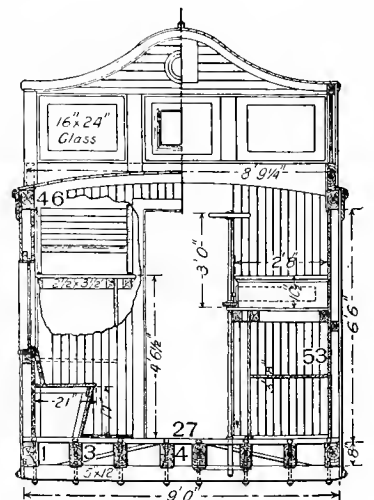

Fig. 384. Half End Elevation.

Numbers Refer to List of Names on Preceding Page.

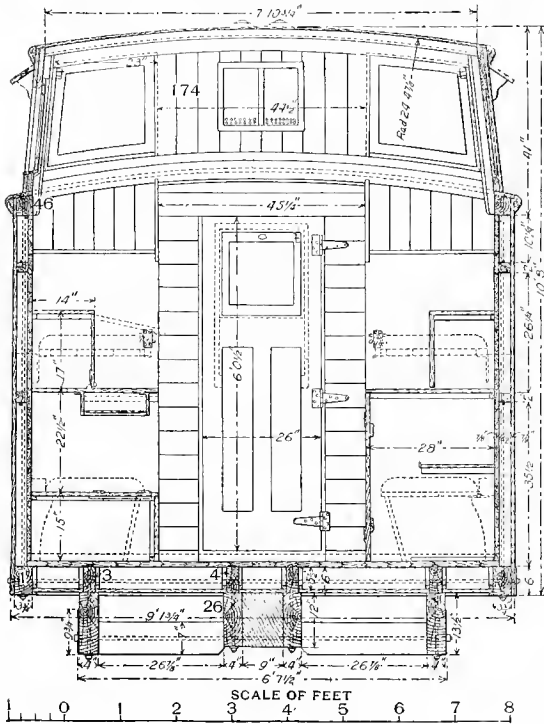

Fig. 387. Transverse Section.

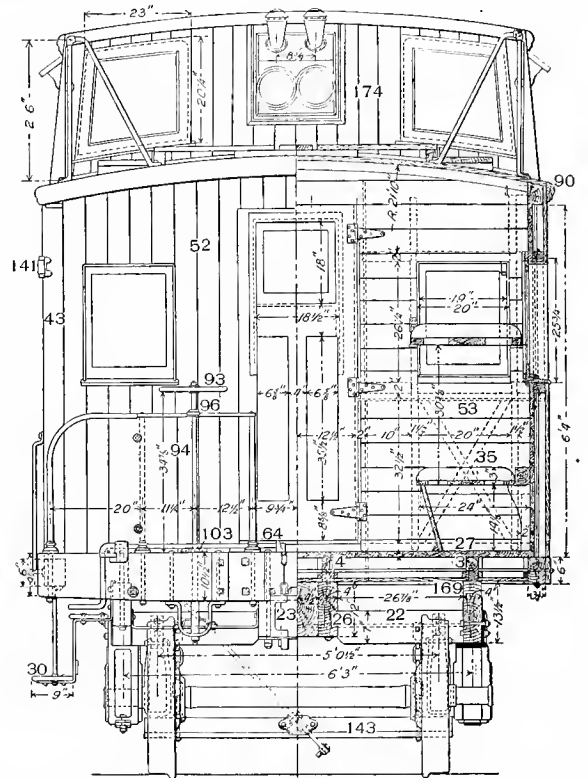

Fig. 388. Half End Elevation and Half Cross Section.

FOUR-WHEELED CABOOSE. NEW YORK, LAKE ERIE & WESTERN RAILROAD.

Numbers Refer to List of Names on Opposite Page.

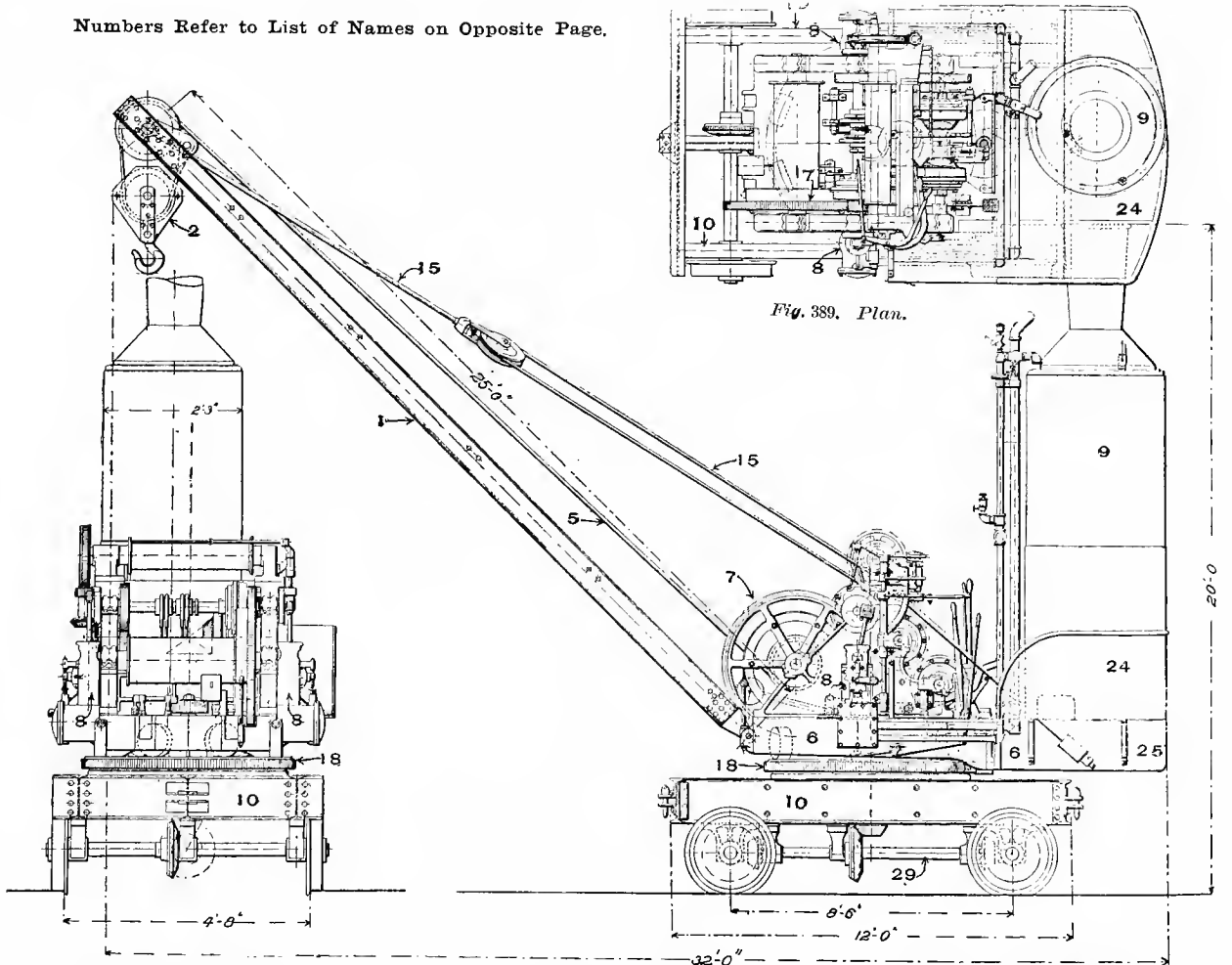

Fig. 390. End Elevation.

Fig. 391. Side Elevation.

(General View is Shown in Fig. 211.)

LOCOMOTIVE CRANE. BUILT BY YALE & TOWNE MANUFACTURING COMPANY.
Length, 32 ft. Capacity, 10 tons. Weight, 56,000 lbs.

Numbers refer to List of Names of Parts of Cranes and Derricks, Figs. 389, 396 and 207.

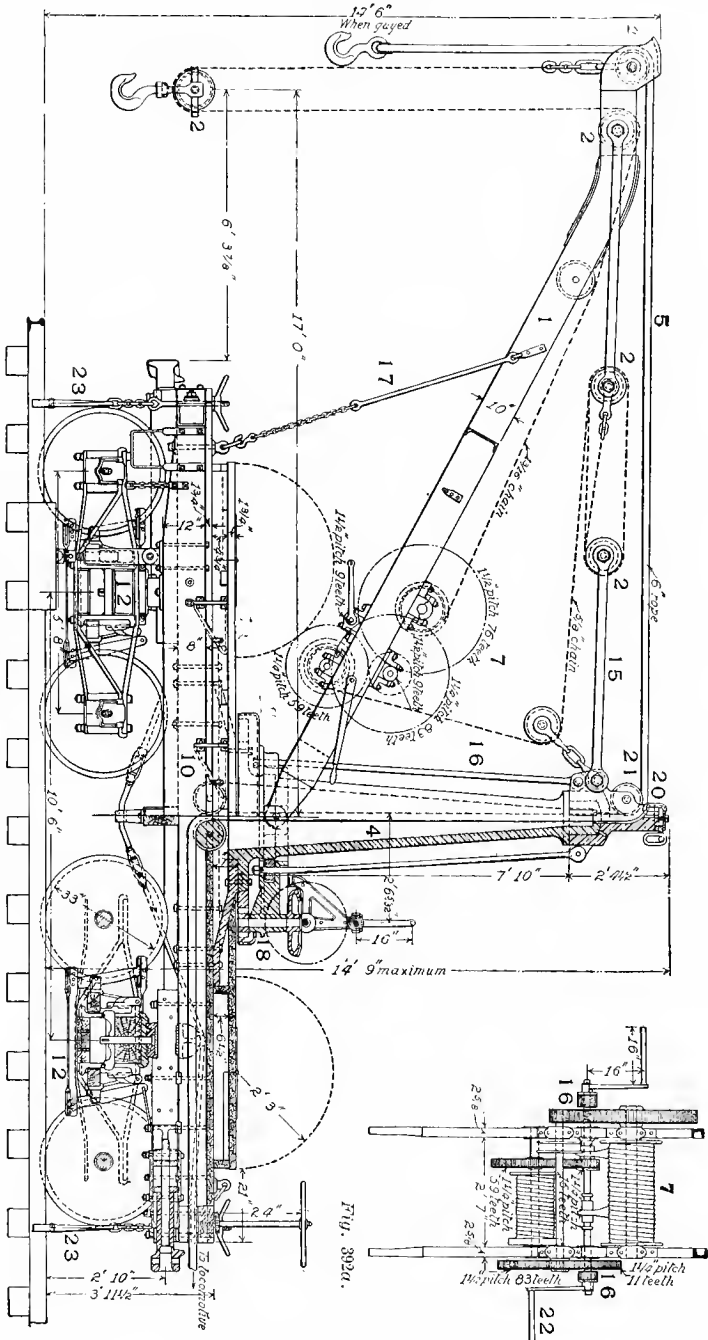

Fig. 392. Side Elevation.
HAND DERRICK CAR. BALTIMORE & OHIO RAILROAD.
Capacity, 20,000 lbs. Sweep, 31 ft.

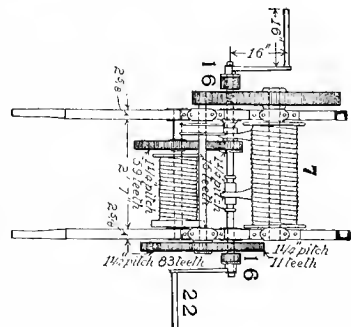

Fig. 392d.

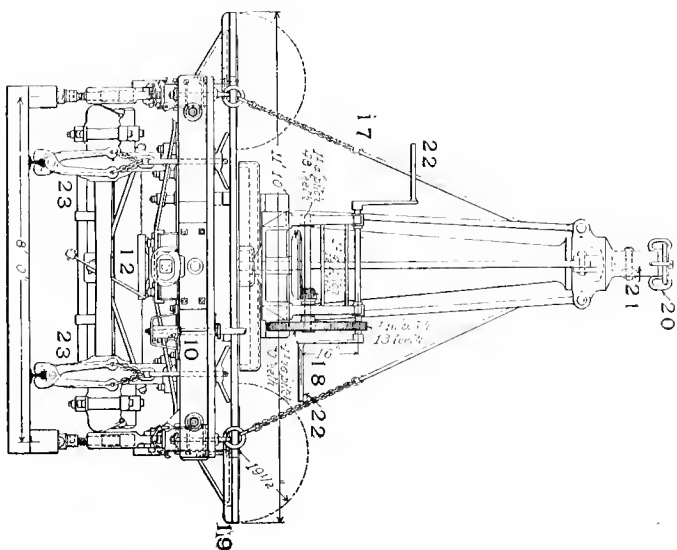
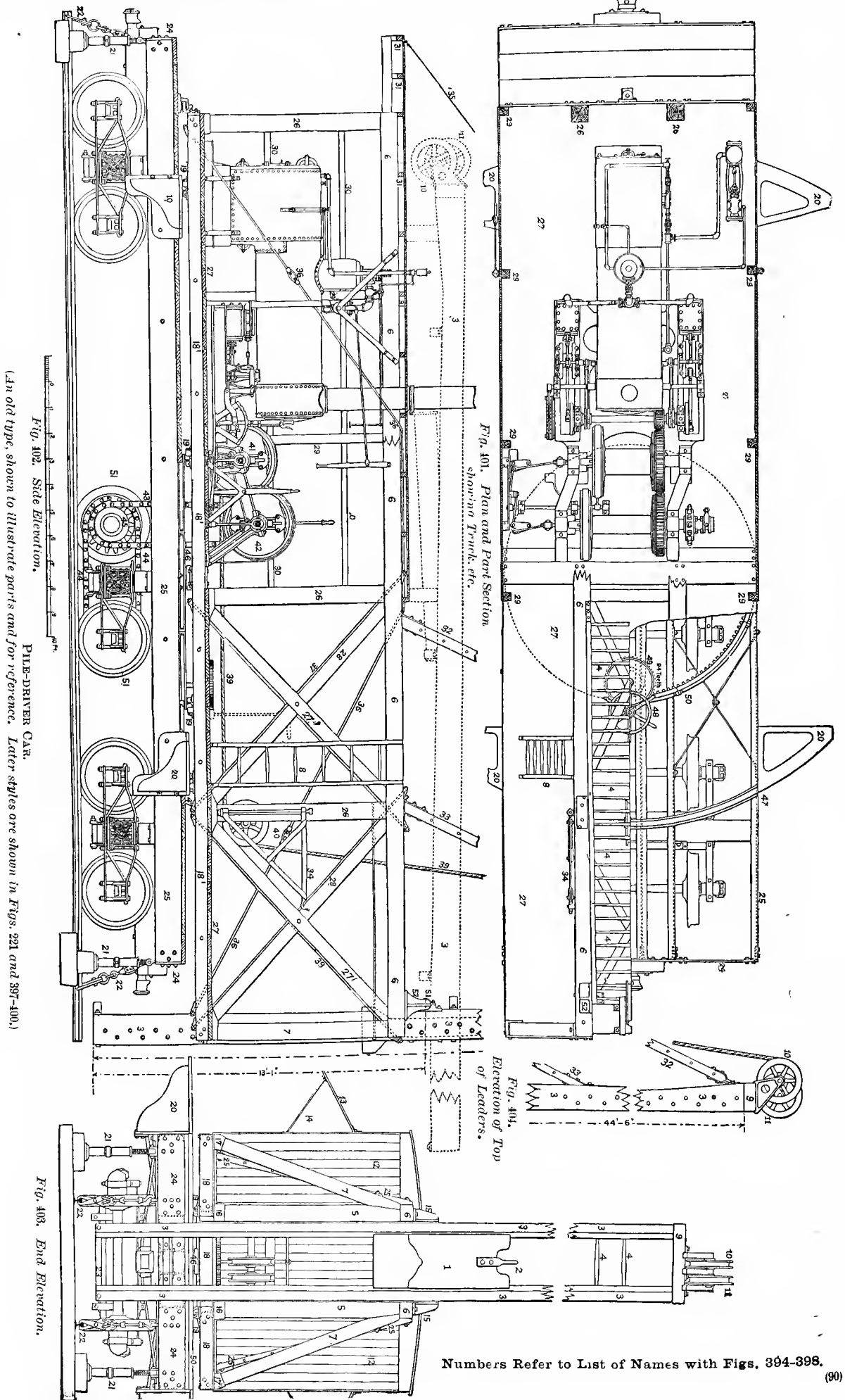

Fig. 388. End Elevation.

- | | | | | |
|--------------------------------------|---|--|-----------------------------|---|
| 1. Steel Jib or Boom. | 9. Upright Boiler. | 14. Removable Pin for Traveiling. | 20. Mast Gunglink. | 27. Removable I-beam. |
| 2. Sheaves and Pulley-blocks. | 10. Car-body. | 15. Boom Tie-rod or Boom Raising-chain. | 21. Mast Pulley. | 28. Operating Levers. |
| 3. Frame, Supporting Jib. | 11. Equidistant-frame for Distributing Load on Forward End of Car. | 16. Mast Stay or Gung. | 22. Operating-crank. | 29. Chain-wheel Driving-gale or Propelling-shaft. |
| 4. Mast or Crane-post. | | 16a. Boom Tie-rod Gear. | 23. Rail-clips or Clumps. | 30. Blocking-up Jacks. |
| 5. Slaving-rope or Chain. | | 17. Gugs for Boom. | 24. Coal-box. | 31. Mast Frame for Machinery. |
| 6. Slaving-rack or Platform for Jib. | 12. Trucks. | 18. Rotating Mechanism or Revolution Wheels. | 25. Counterpoise Platform. | |
| 7. Hoisting-gear or Windlass. | 13. Trunnion Support Used in Lowering Jib Preparatory for Traveiling. | 19. Wing Platform. | 26. Rail-clamp Hand-screws. | |
| 8. Hoisting-engine Cylinders. | | | | |



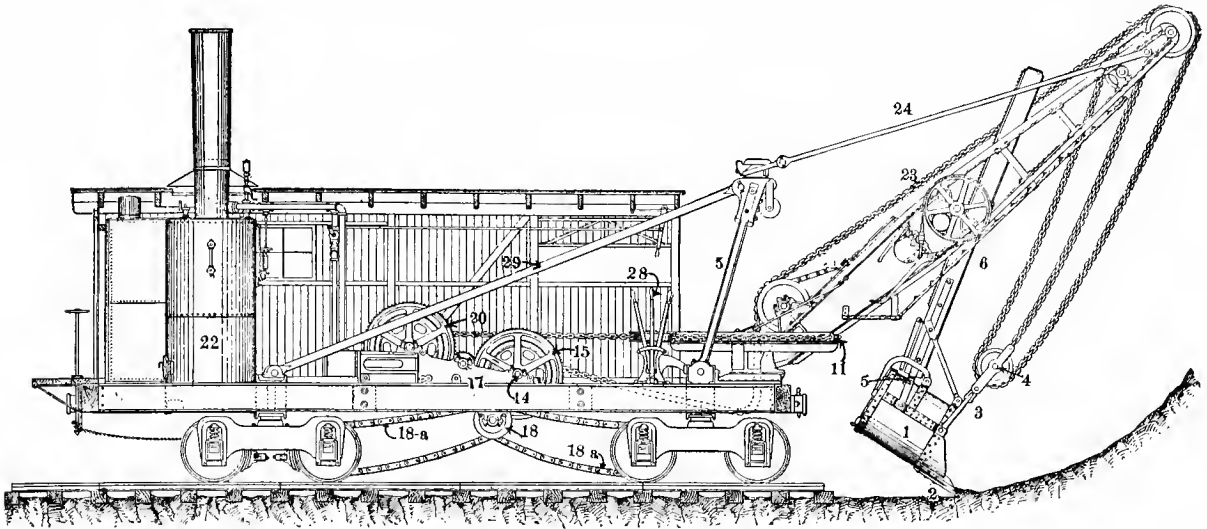

Fig. 405. Sectional Side Elevation showing Dipper just before filling.

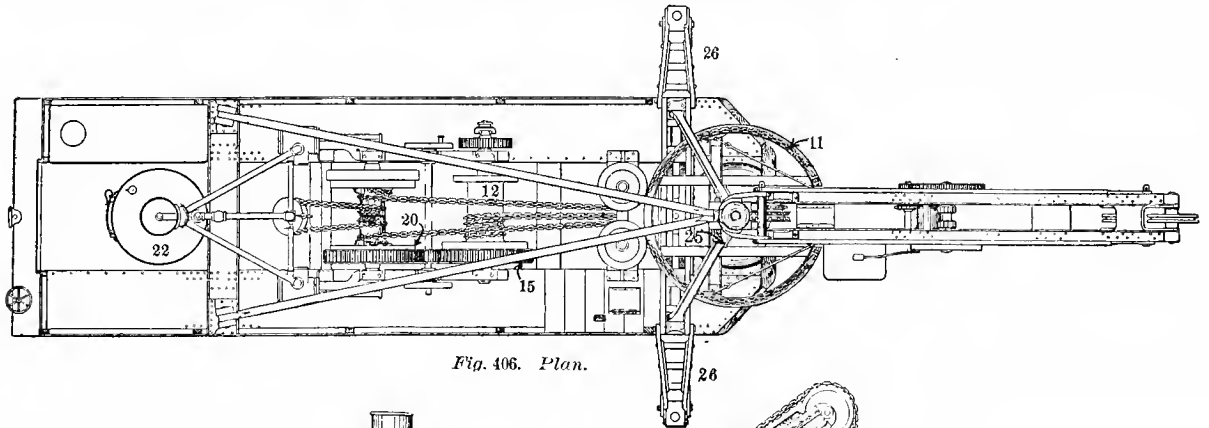

Fig. 406. Plan.

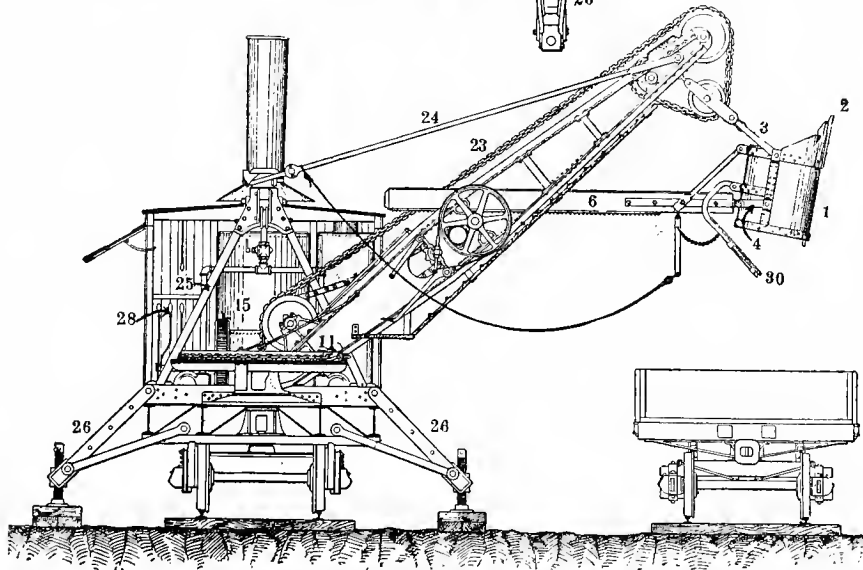

Fig. 407. End Elevation showing Dipper just after dumping.

STEAM SHOVEL, BOOM PATTERN. BUCYRUS STEAM SHOVEL & DREDGE COMPANY.

Engine cylinders, 8 x 12 in Boom, 23 ft. Dipper, 1 3/4 cu. yds. Car, 10 ft. x 30 ft. Fox Trucks, 60,000 lbs. capacity.

NAMES OF PARTS OF STEAM SHOVEL. Figs. 405-407 and 208.

- | | | | |
|-------------------------------------|----------------------------------|---------------------------|-------------------------|
| 1. Dipper. | 8. Valve Hand-wheel and Spindle. | 15. Spur-wheel. | 23. Hoisting-chain. |
| 2. Teeth. | 9. Coil Steam-pipe. | 16. Disc-crank. | 24. Boom Tie-rod. |
| 3. Bail. | 10. Slip-joint. | 17. Engine Bed-plate. | 25. "A"-frame. |
| 4. Block. | 11. Mast-wheel or Boom-wheel. | 18. Spur-wheel. | 26. Jack-arms. |
| 5. Handle. | 12. Chain-spool. | 18a. Chain-wheel. | 28. Operating Levers. |
| 6. Dipper-cylinder or Ratchet-beam. | 13. Friction-brake Wheel. | 19. Mast Base-casting. | 29. "A"-frame Stay-bar. |
| 7. Trunnion-bearings with Cap. | 14. Drum-shaft. | 20. Swing-cylinder. | 30. Dipper-bottom. |
| | | 21. Swing-cylinder Valve. | |
| | | 22. Boiler. | |

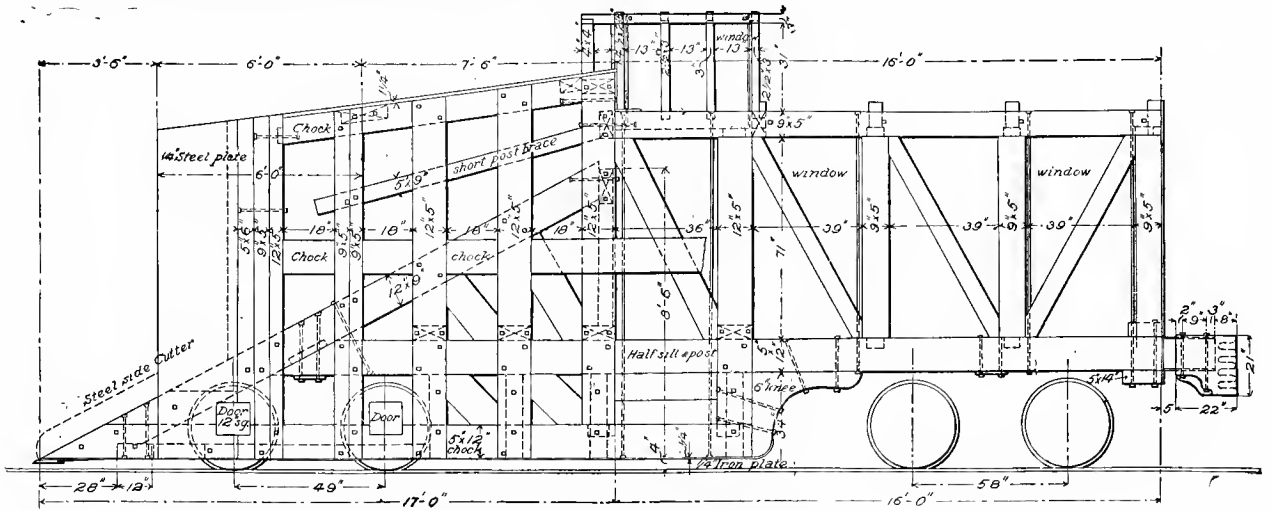

Fig. 408. Side Elevation of Framing.

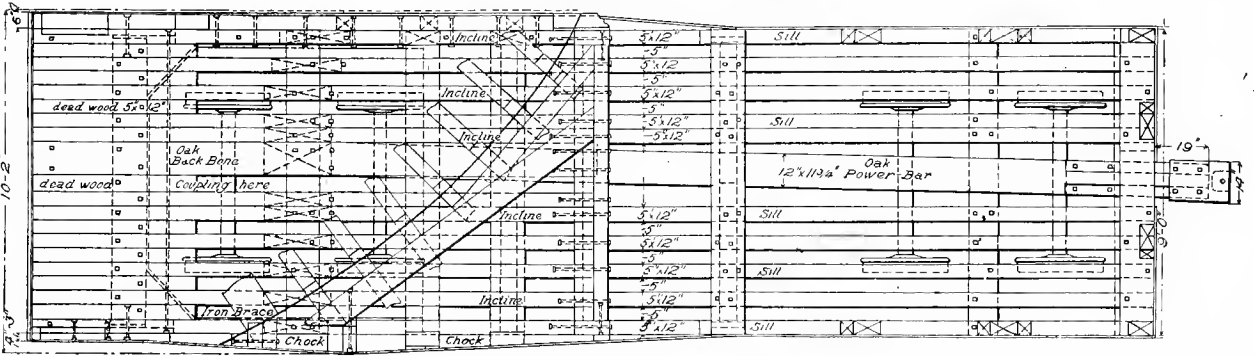

Fig. 409. Plan of Framing.

DOUBLE-TRACK SNOW PLOW (RUSSELL'S), ENSIGN MANUFACTURING COMPANY.
(A general view is shown in Fig. 224.)

Numbers Refer to List of Names on Opposite Page.

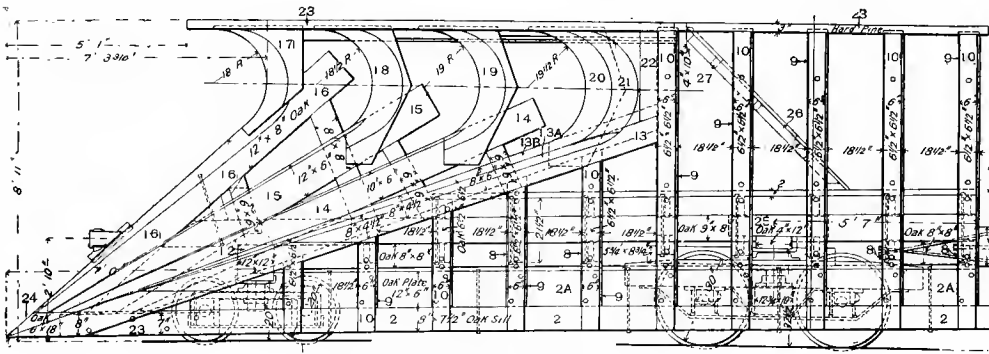

Fig. 410. Side Elevation of Framing.

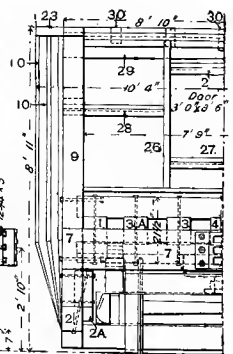

Fig. 412. Half Rear End Elevation.

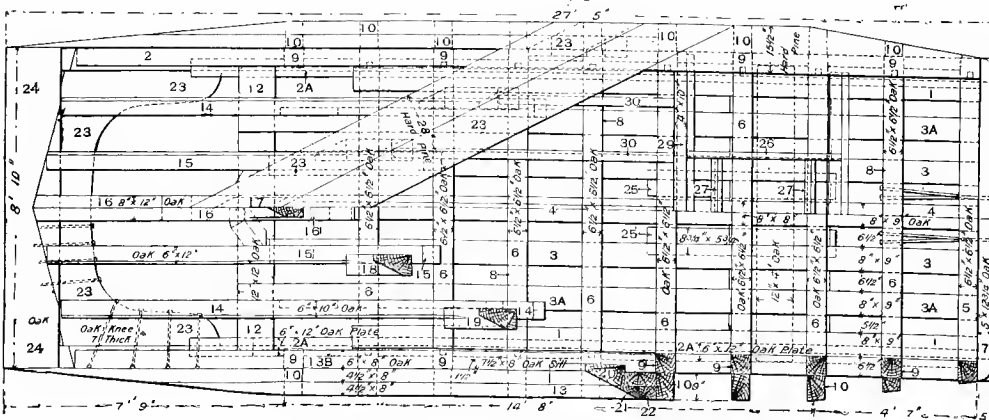

Fig. 411. Half Plan and Half Horizontal Section.

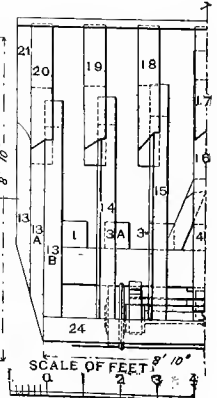

Fig. 413. Half Front End Elevation.

SNOW PLOW, BUILT BY THE PORTLAND COMPANY, PORTLAND, MAINE.

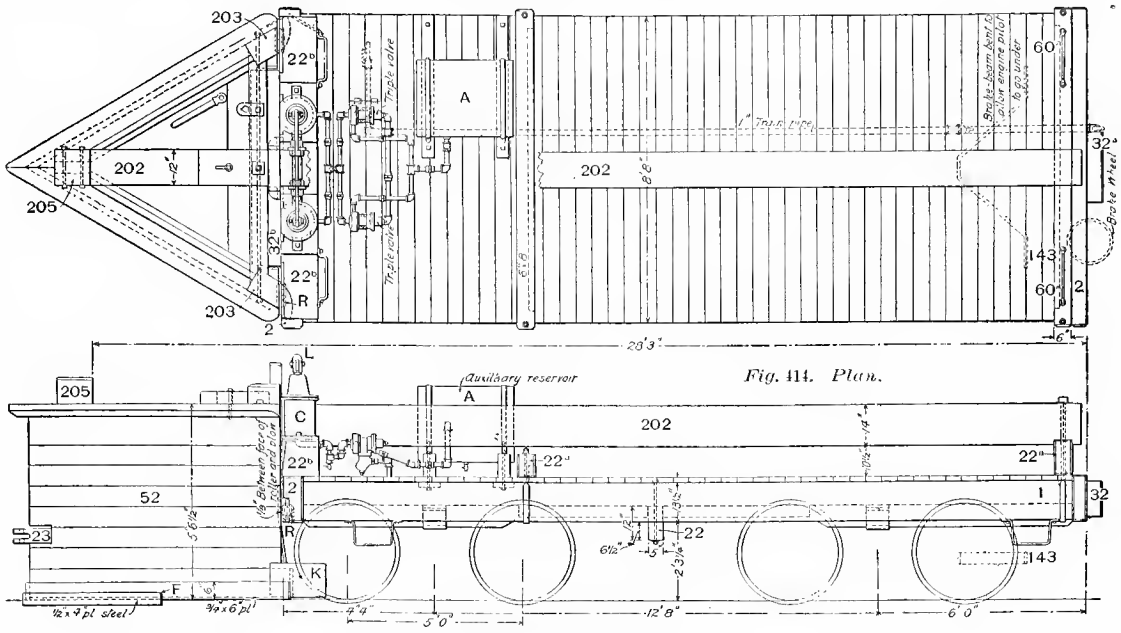

Fig. 415. Side Elevation.

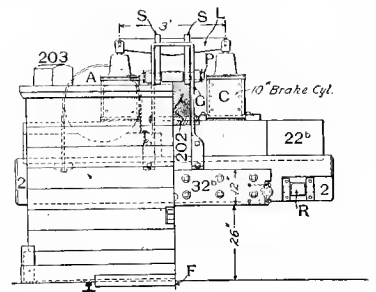
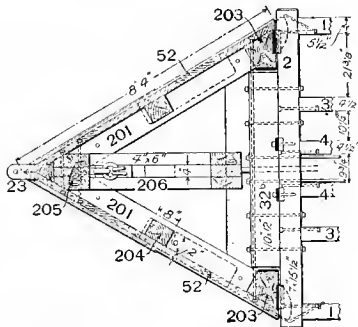
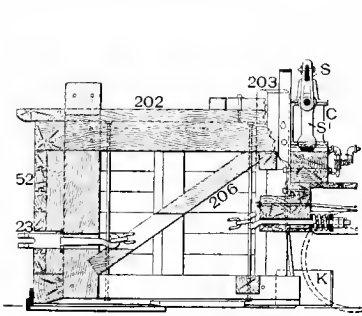

Fig. 415. Longitudinal Section.

Fig. 417. Horizontal Section.

Fig. 418. Half End Elevation and Cross Section.

SNOW PLOW AND FLANGER MICHIGAN CENTRAL RAILROAD.
(To be Attached to a Flat Car.)

NAMES OF PARTS OF SNOW PLOW OR FLANGER. Figs. 414-418.

- | | | | |
|------------------------|----------------------------------|----------------------------|-------------------------|
| 1. Side-sill. | 22b. Transversely Filling-block. | 143. Bent Brake-beam. | A. Auxiliary Reservoir. |
| 2. End-sill. | 23. Draw-bar. | 201. Diagonal Chock-piece. | C. Air-cylinders. |
| 3. Intermediate-sill. | 32b. Buffer-beam (Same as 32). | 202. Plow Suspension-beam. | F. Steel Flange-plate. |
| 4. Center-sill. | 52. Planking of Plow. | 203. Corner Guide-post. | K. Steel Flanger. |
| 22. Cross-tie-timber. | 60. Hand-hold. | 204. Post of Plow. | L. Piston Lever-bar. |
| 22a. Cross-tie-timber. | | 205. Center Forward-post. | R. Roller-guide. |
| | | 206. Diagonal-strut. | S. Stirrup. |

NAMES OF PARTS OF SNOW-PLOW BODY. Figs. 410-413.

- | | | | |
|------------------------|-------------------------------------|--|--|
| 1. Side-sill. | 6. Top-girts or Cross-tie timber. | 13 and 13a. Furring-pieces. | 23. Out-knee. |
| 2. Bottom-sill. | 7. Butler Beam. | 13b, 14, 15. Shear-beams. | 23'. Deck-timber. |
| 2a. Side-plate. | 8. Bottom-girt or Cross-tie-timber. | 16. Stem. | 24. Front End-sill. |
| 3. Intermediate-sill. | 9. Post. | 17. Center Throat-piece. | 25. Center Iron-timbers. |
| 3a. Intermediate-sill. | 10. Gurring-piece. | 18 and 19. Intermediate Throat-pieces. | 26 and 27. Frame for Door in Bulkhead. |
| 4. Center-sill. | 12. Front Body-bolster. | 20. Side Throat-piece. | 29 and 30. Bulkhead and Deck-timber. |
| 5. End-girt. | | 21 and 22. Furring-pieces. | |

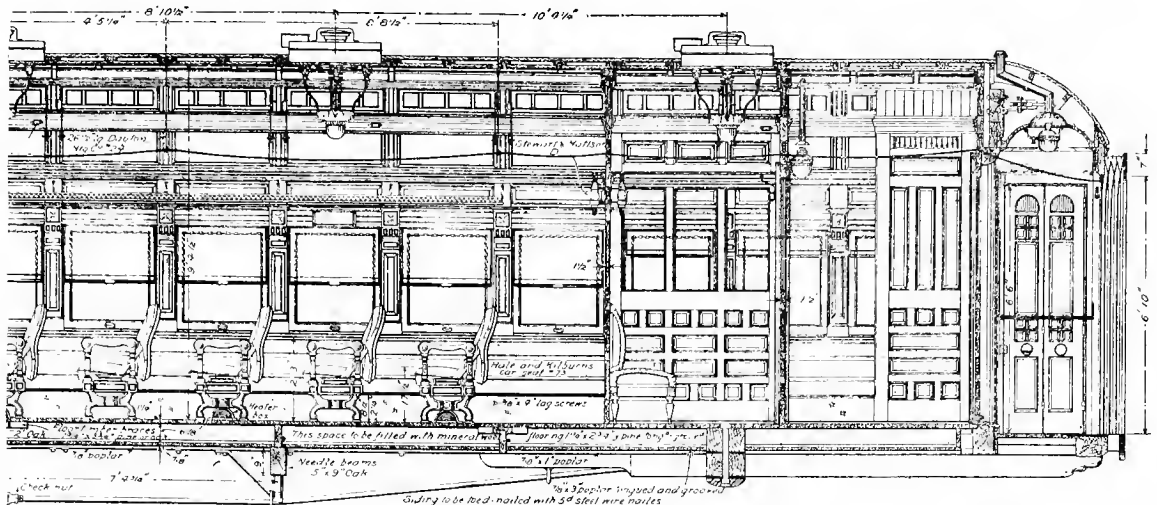

Fig. 422. Half Side Elevation of Interior.

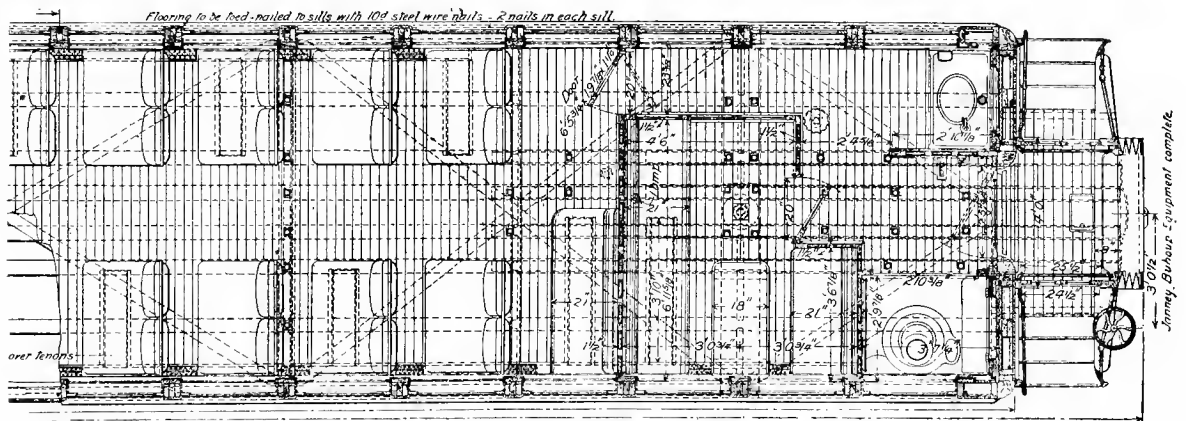

Fig. 423. Half Plan of Interior and Section of Sides

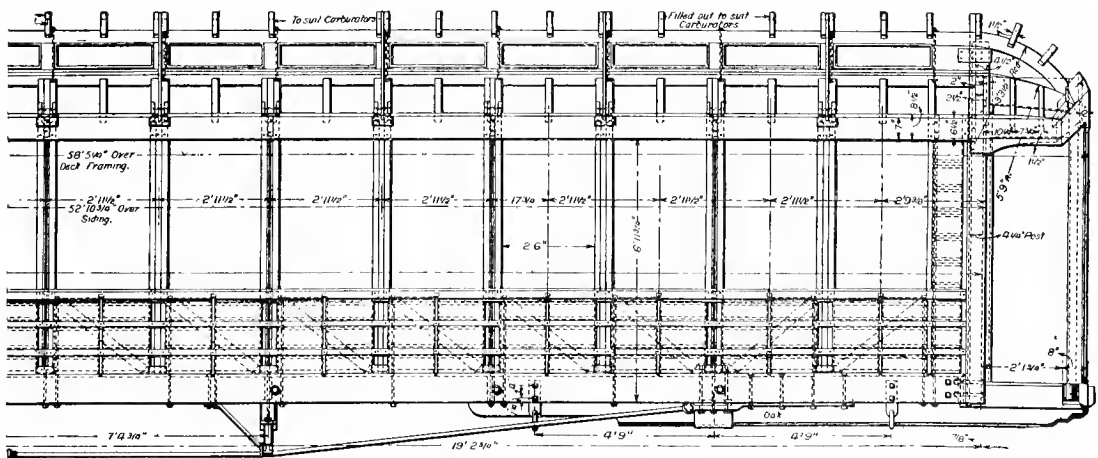

Fig. 424. Side Elevation of Framing.

Numbers Refer to List of Names of Parts with Figs. 441-446.

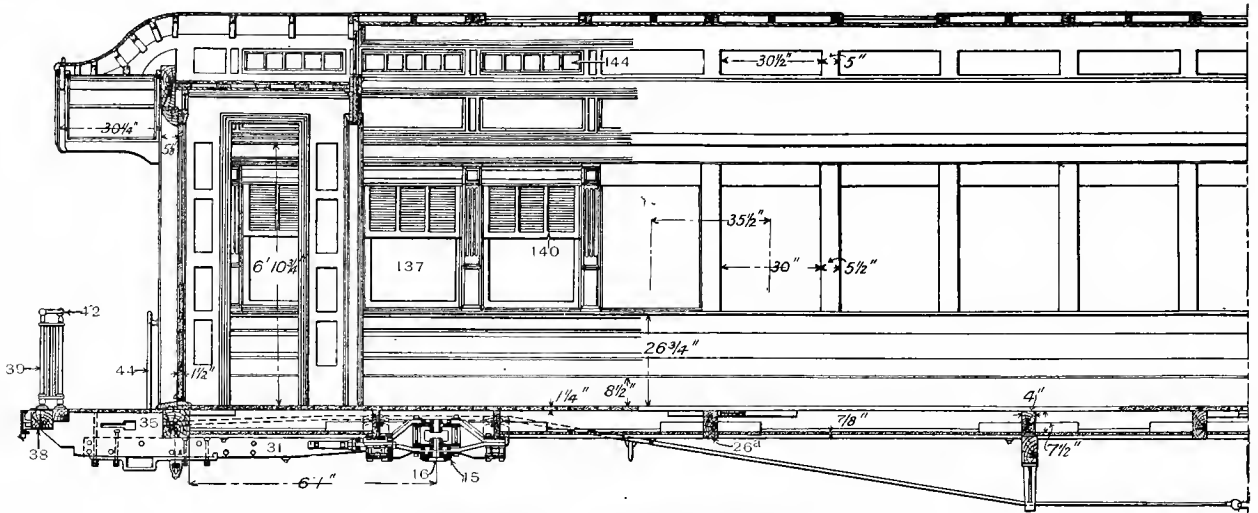

Fig. 435. Part Longitudinal Section and Sectional View of Interior.

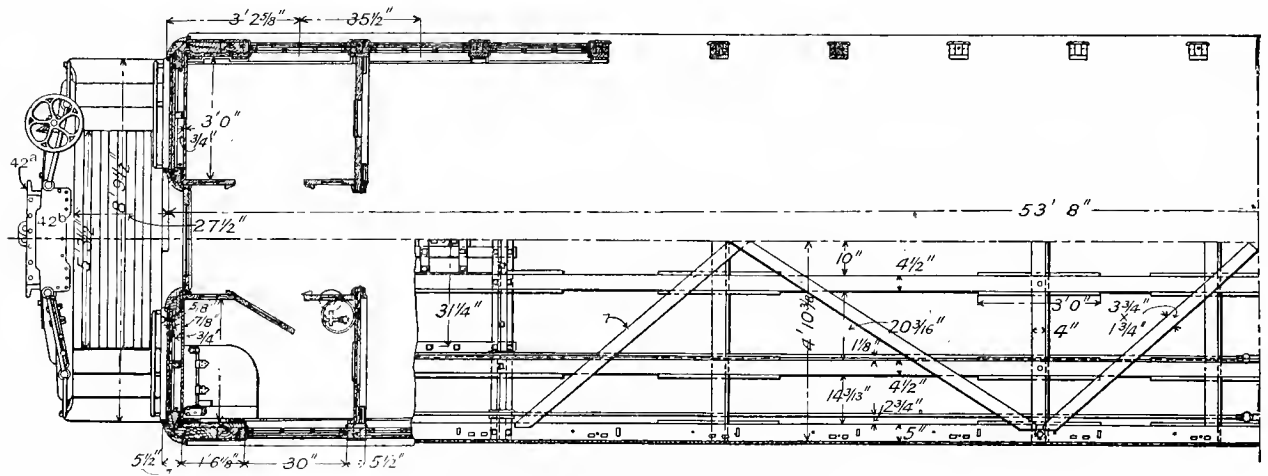

Fig. 436. Half Plan of Underframing and Floor.

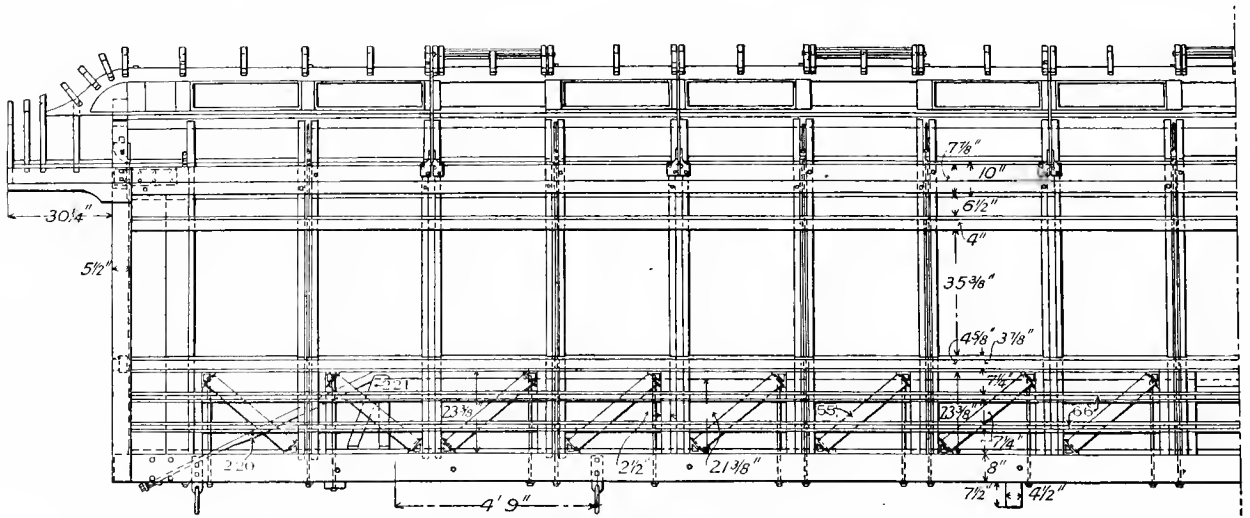

Fig. 437. Side Elevation showing Framing.

FIRST-CLASS PASSENGER COACH. PENNSYLVANIA RAILROAD.

Numbers Refer to List of Names of Parts with Figs. 441-446.

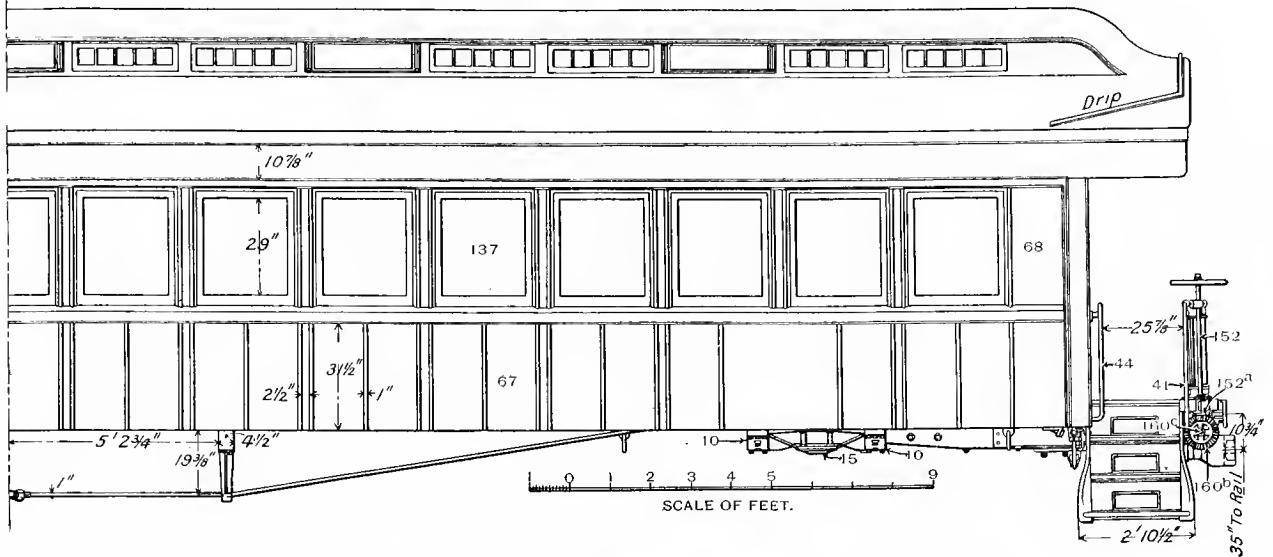

Fig. 438. Side Elevation of Exterior.

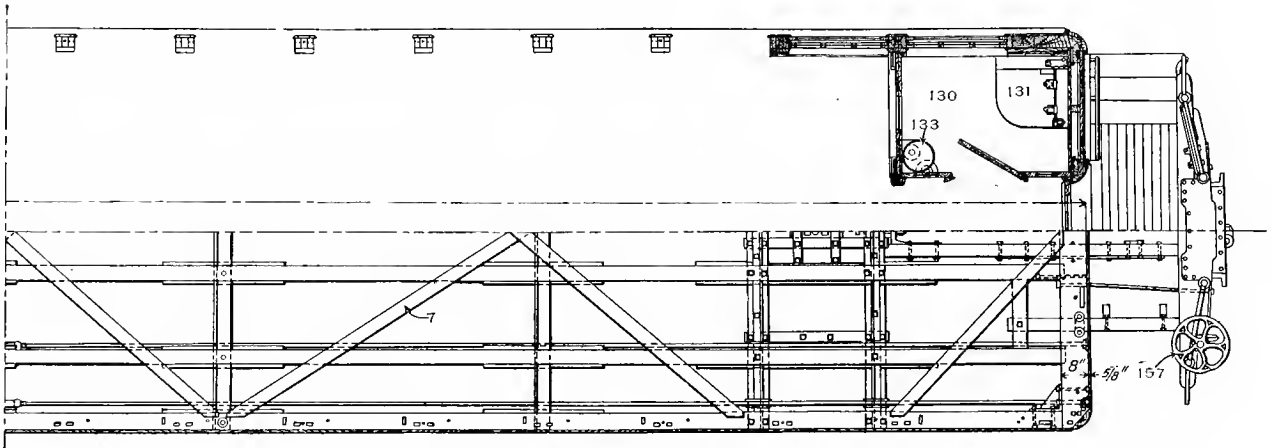

Fig. 439. Part Plan of Underframing.

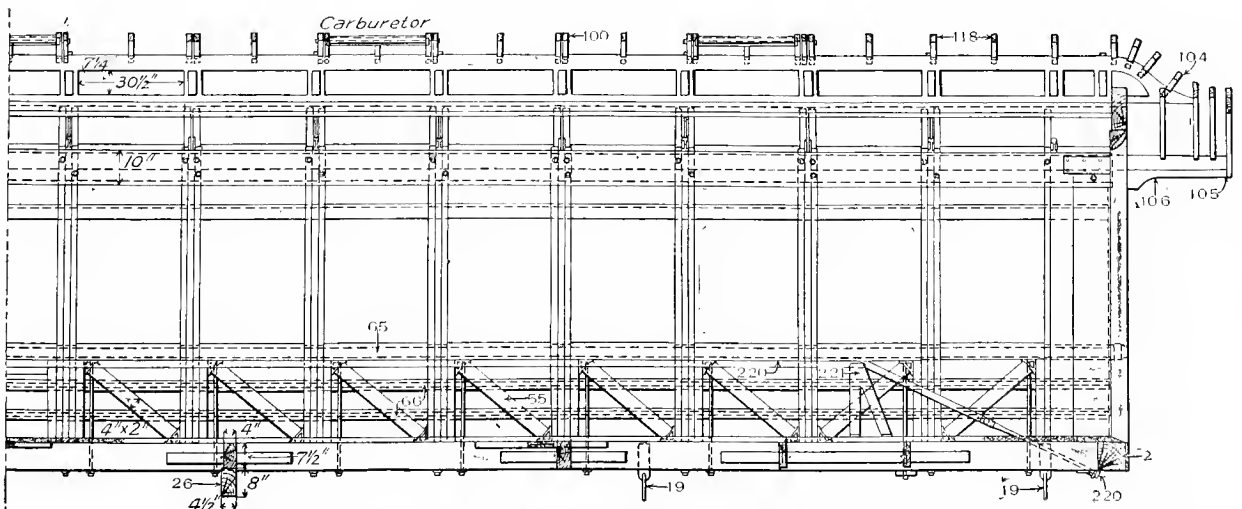

Fig. 440. Side Elevation showing Framing.

FIRST-CLASS PASSENGER COACH. PENNSYLVANIA RAILROAD.

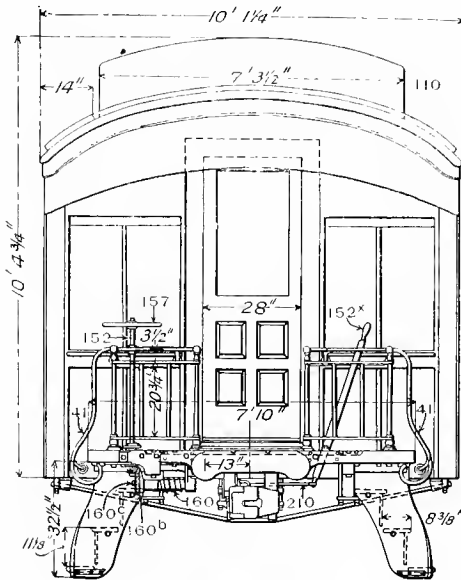

Fig 441. End Elevation.

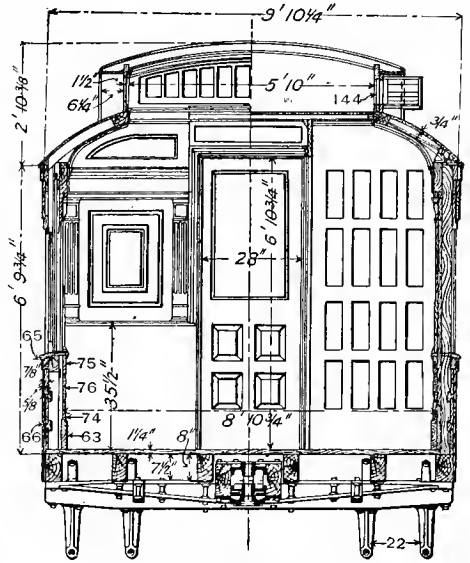

Fig. 442. Transverse Section.

FIRST-CLASS PASSENGER-COACH BODY. PENNSYLVANIA RAILROAD.

NAMES OF PARTS OF PASSENGER CAR-BODIES. Figs. 435-473.

- | | |
|---|--|
| 1. Side-sill. | 32. Center-draft Drawbar. |
| 2. End-sill. | 34. Platform-floor. |
| 3. Intermediate-sill. | 35. Platform-sill. |
| 3a. Outer Intermediate-sill. | 37. Platform Short-sill. |
| 4. Center-sill. | 38. Platform End-sill. |
| 5. Floor-timber Distance-block. | 39. Platform Railing-post. |
| 6. Bridging. | 40. Base Washer for Platform Railing-post. |
| 7. Floor-timber Brace. | 41. Platform-rail. |
| 8. Sill Knee-iron. | 42. Same as 41 in Fig. 435. |
| 9. Sill Tie-rod. | 42. Platform Hand-rail Chain. |
| 10. Body-bolster. | 42a. Buffer-plate (Fig. 436). |
| 11. Body-bolster Truss-rod. | 42b. Foot-plate (Fig. 436). |
| 12. Body-bolster Truss-rod Washer. | 44. Body Hand-rail. |
| 12a. Upper Bolster-plate. | 45. Platform-step. |
| 12b. Lower Bolster-plate. | 46. Tread-board. |
| 13. Body-bolster Truss-block. | 47. Step-iron. |
| 14. Body Side-bearings. | 48. Step-hanger. |
| 15. Body Centre-plate. | 48b. Step-hanger Brace. |
| 16. King-bolt. | 49. Splash-board. |
| 17. King-bolt Plate. | 51. Brace. |
| 18. Check-chain. | 52. Brace-rod. |
| 19. Body Check-chain Eye. | 53. Brace-rod Straining-rod. |
| 20. Body Truss-rod. | 54. Sill-and-plate Rod. |
| 21. Body Truss-rod Saddle. | 55. Counterbrace. |
| 22. Body Queen-post | 56. Counterbrace Rod. |
| 22a. Body Queen-post Brace. | 57. Brace-rod Washer. |
| 23. Turnbuckle. | 58. Window-post. |
| 24. Truss-rod Anchor-iron. | 59. Sheathing Furring. |
| 26. Cross Tie-timber. | 60. Stud. |
| 26a. Intermediate Cross Tie-timber. | 61. Corner-post. |
| 27. Floor. | 62. Door-post. |
| 26a. Intermediate Cross-frame-tie-timber. | 63. Truss-plank. |
| 28. Deafening Ceiling. | 64. Truss-plank Cap. |
| 29. Drawbar. | 65. Belt-rail. |
| 30. Draft-spring. | 66. Sheathing-rail. |
| 31. Draft-timber. | 67. Outside Panel or Sheathing. |

(Continued.)

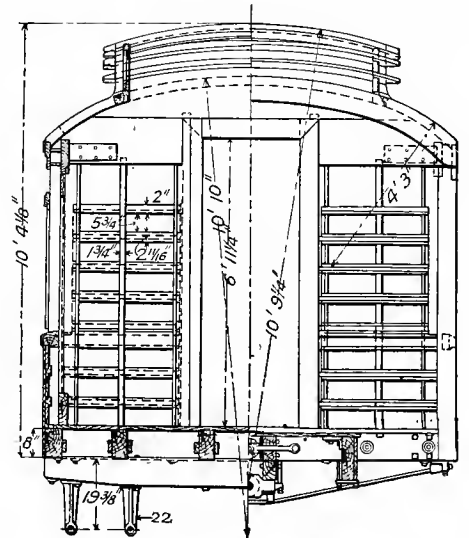

Fig. 443. End Elevation Framing.

- | |
|--|
| 67a. Sheathing. |
| 68. Outside Window-panel or Sheathing. |
| 69. Sheathing-strips. |
| 70. Sheathing (70a). |
| 71. Sheathing. |
| 74. Lower Wainscot-rail. |
| 75. Upper Wainscot-rail. |
| 76. Wainscot-panel. |
| 77. Outside Window-sill. |
| 78. Inside Window-sill. |
| 79. Window-sill Cap. |
| 80. Window-sill Moulding. |
| 81. Belt-rail Cap. |
| 82. Upper Belt-rail. |
| 83. Sash Parting-strip. |
| 84. Outside Window-stop. |

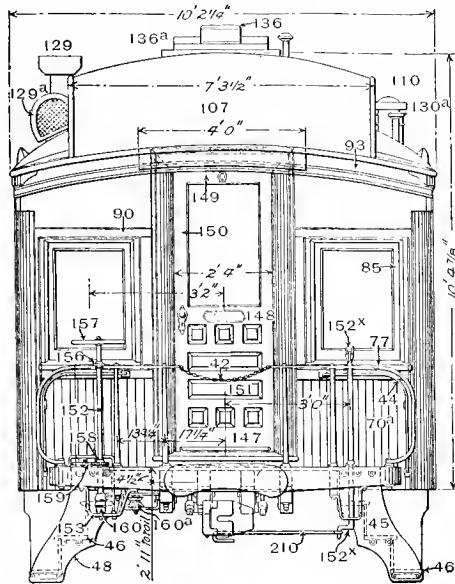

Fig. 444. End Elevation.

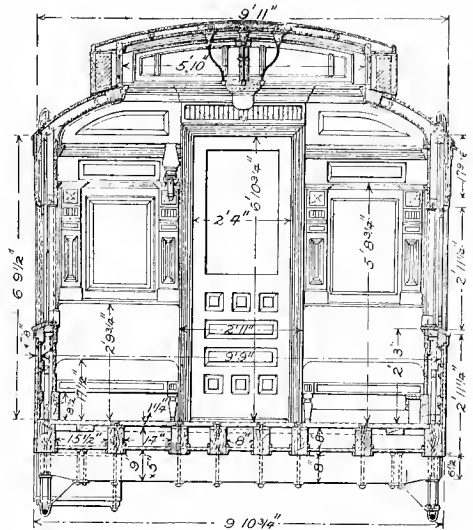

Fig. 445. Transverse Section.

COMBINATION PASSENGER AND BAGGAGE-CAR BODY. NORFOLK & WESTERN RAILROAD.

NAMES OF PARTS OF PASSENGER CAR-BODIES. Figs. 435-473.

(Continued)

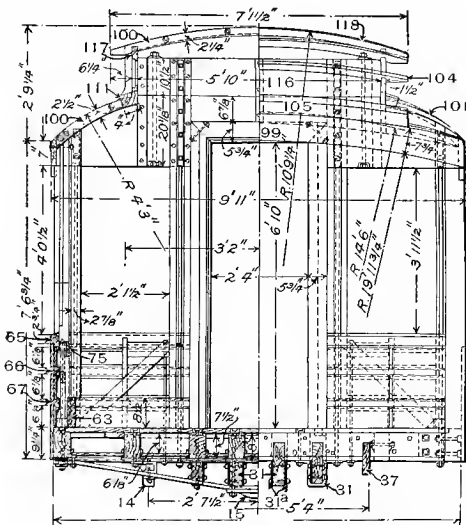
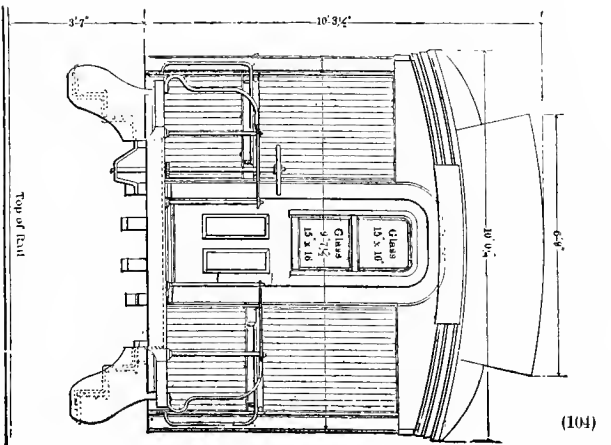
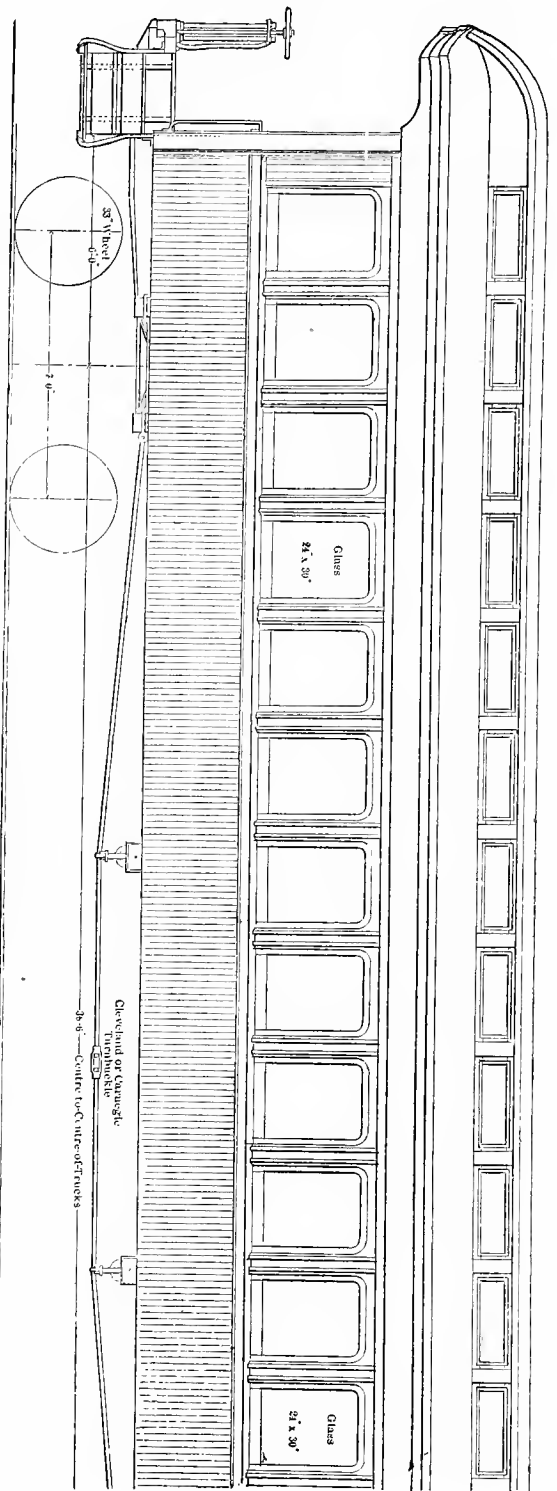
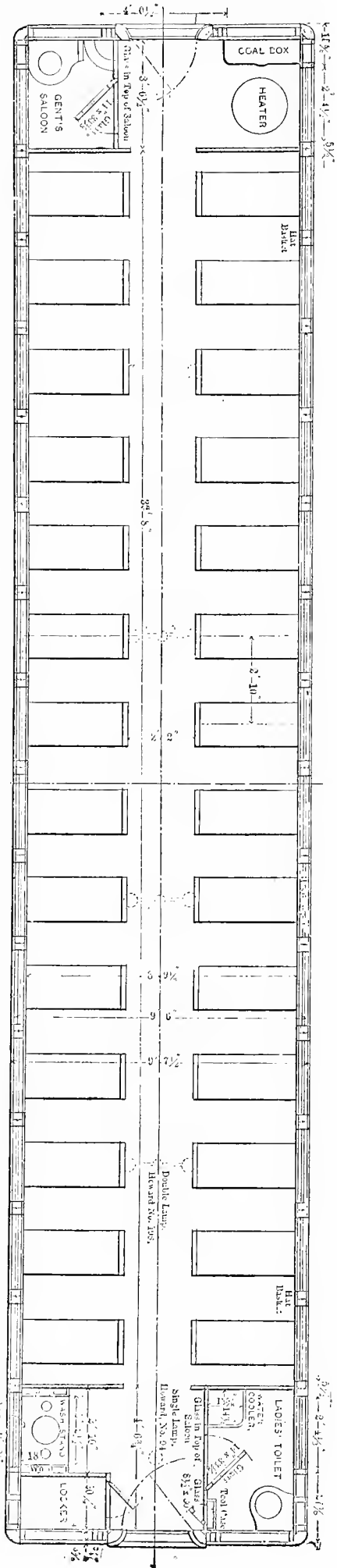

Fig. 446. End Elevation of Framing.

- 85. Window Sash.
- 86. Window Blind-sash.
- 86'. Inside Window-stop or Window-casing.
- 87. Window Cove-moulding.
- 88. Window-moulding.
- 89. Inside Window-pannel.
- 90. Window-lintel.
- 91. Letter-board.
- 92. Fascia-board.
- 93. Eaves-moulding.
- 94. Inside Cornice.
- 95. Inside Cornice Fascia-board.
- 96. Inside Cornice Sub-fascia-board.
- 97. Inside Lining.
- 98. Plate.
- 99. Door-lintel.
- 100. Carline or Compound Carline.
- 101. Rafter.
- 102. Roof-boards.
- 102a. Sash-balance (Fig. 447).

- 103. Platform Roof.
- 104. Platform-roof Carline.
- 105. Platform-roof End Carline.
- 106. Roof-apron.
- 107. Platform Hood.
- 108. Platform-hood Bow.
- 109. Platform-hood Post.
- 110. Clear-story or Upper-deck.
- 111. Deck-sill.
- 112. Same as 111 in Fig. 462.
- 112. Deck Bottom-rail.
- 113. Deck End-sill.
- 114. Deck-sill Facing.
- 115. Deck Post.
- 116. Deck End-pannel or Ventilator.
- 117. Deck-plate.
- 118. Upper-deck Carline.
- 119. Upper-deck Eaves-moulding.
- 120. Inside Deck-cornice.
- 121. Deck Soffit-board.
- 122. Car Seat.
- 123. Seat-end or Aisle Seat-end.
- 124. Seat-stand.
- 125. Seat-back.
- 127. Foot-rest.
- 128. Stove or Heater.
- 129. Stove-pipe Jack.
- 129a. Smoke-pipe Jack (Fig. 444).
- 130. Saloon.
- 130a. Saloon Ventilator-pipe.
- 131. Closet Hopper.
- 132. Urinal.
- 133. Water-cooler.
- 134. Water-alcove.
- 135. Center-lamp.
- 136. Lamp-jack.
- 136a. Fro Carburetter.
- 137. Window.
- 140. Window-blind.
- 140a. Window-shade.
- 141. Frieze Ventilator.
- 142. End-ventilator.
- 143. Side Deck-ventilator.
- 143a. Deck Sash-opener.
- 144. Deck-sash or Deck-window.
- 145. Basket-rack.
- 146. Door-mullion.
- 147. Bottom Door-rail.
- 148. Middle Door-rail.
- 149. Top Door-rail.
- 150. Door-stile.
- 151. Door-pannel.
- 152. Brake-shaft.
- 152a. Hand Brake-shaft Bevel Gear-wheel.
- 152x. Uncoupling-staff.
- 153. Brake-shaft Step.
- 155. Lower Brake-shaft Bearing.
- 156. Upper Brake-shaft Bearing.
- 157. Brake Hand-wheel.
- 158. Brake Ratchet-wheel.
- 159. Brake-panl.
- 160. Brake-chain Worm.
- 160a. Brake-chain Sheave.
- 160b. Horizontal Brake-chain-shaft Bevel Gear-wheel.
- 160c. Brake-chain Worm-shaft.
- 161. Flag-holder Socket-plate.
- 162. Platform Tie-rod.
- 163. Compression-beam.
- 164. Compression-beam Brace.
- 164r. Body Counterbrace-rod.
- 165. Counterbrace.
- 167. Overhang Brace-rod.
- 167a. Same as 167.
- 172a. Uncoupling-rod.
- 172. Uncoupling-shaft.
- 173. Uncoupling-lever.
- 210. Uncoupling-rod.
- 220. Same as 167.
- 221. Overhang Brace-rod Strut.



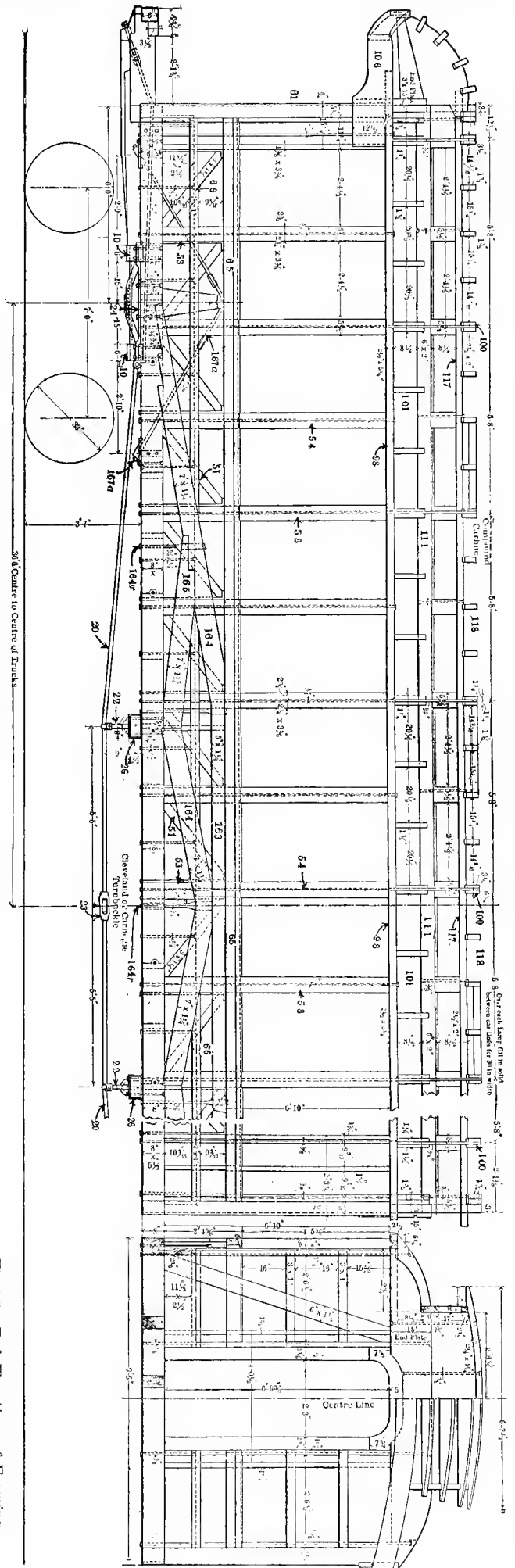

Fig. 456. Part Side Elevation of Framing.

Fig. 457. End Elevations of Framing.

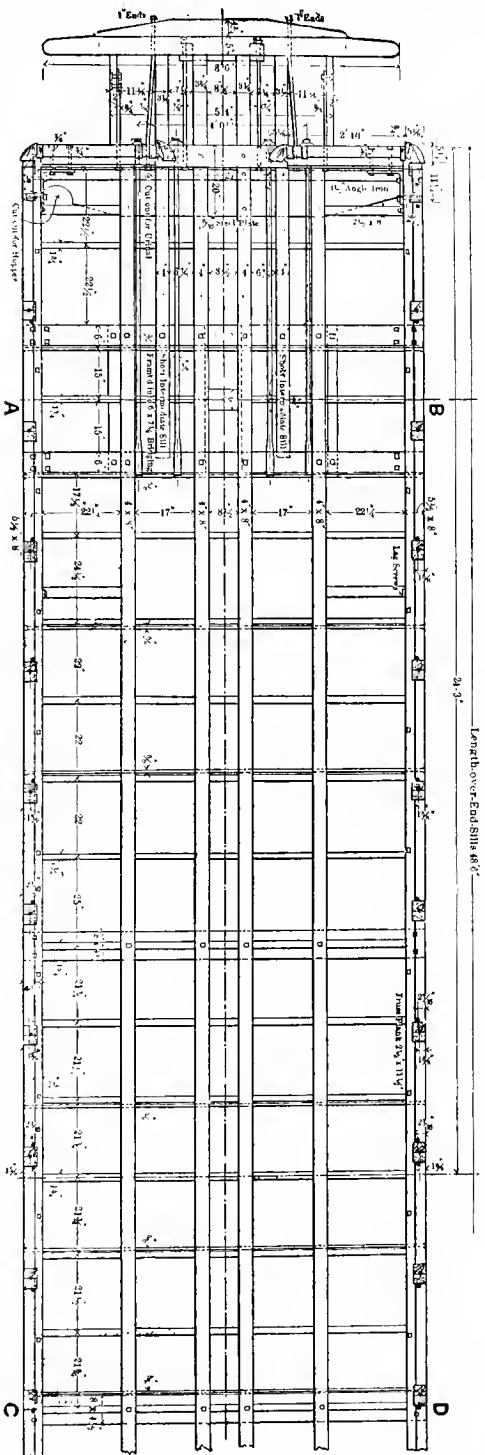
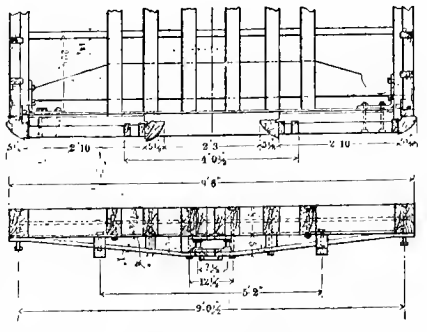
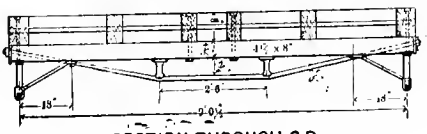

Fig. 458. Part Plan of Underframe.



SECTION THROUGH A B.



SECTION THROUGH C D.

FIRST-CLASS PASSENGER COACH. BALTIMORE & OHIO RAILROAD.

Figs. 459 and 460. Transverse Sections of Underframe.

Numbers refer to List of Names with Figs. 441-446.

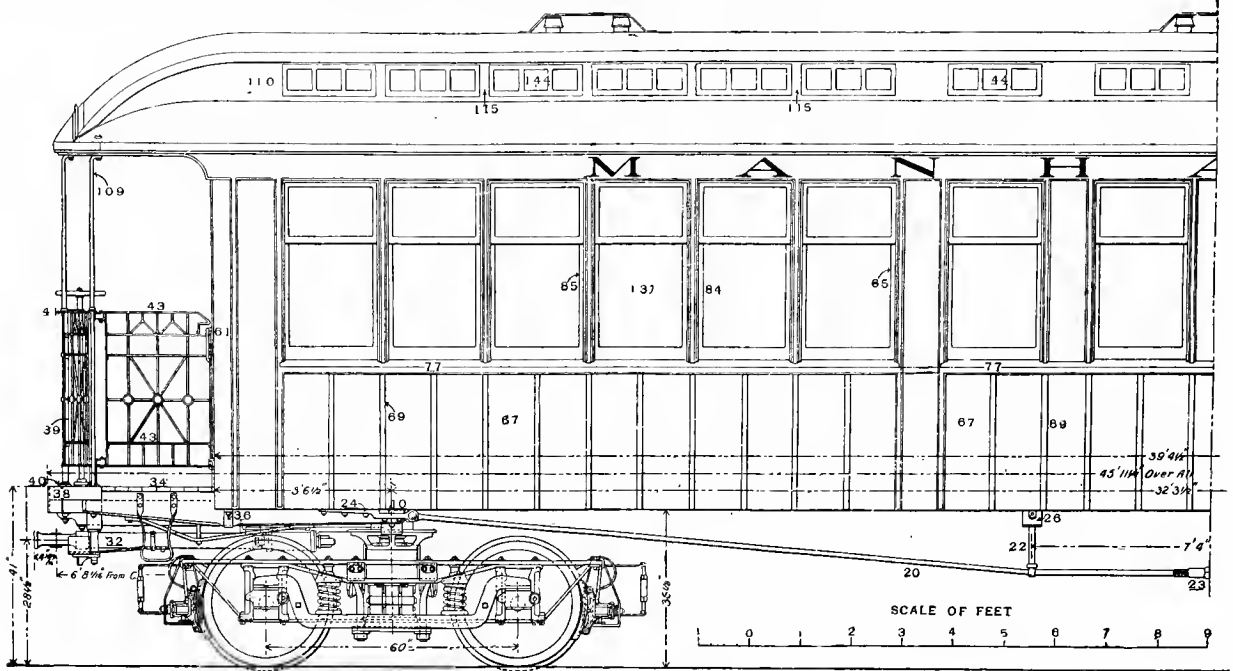

Fig. 461. Half Side Elevation.

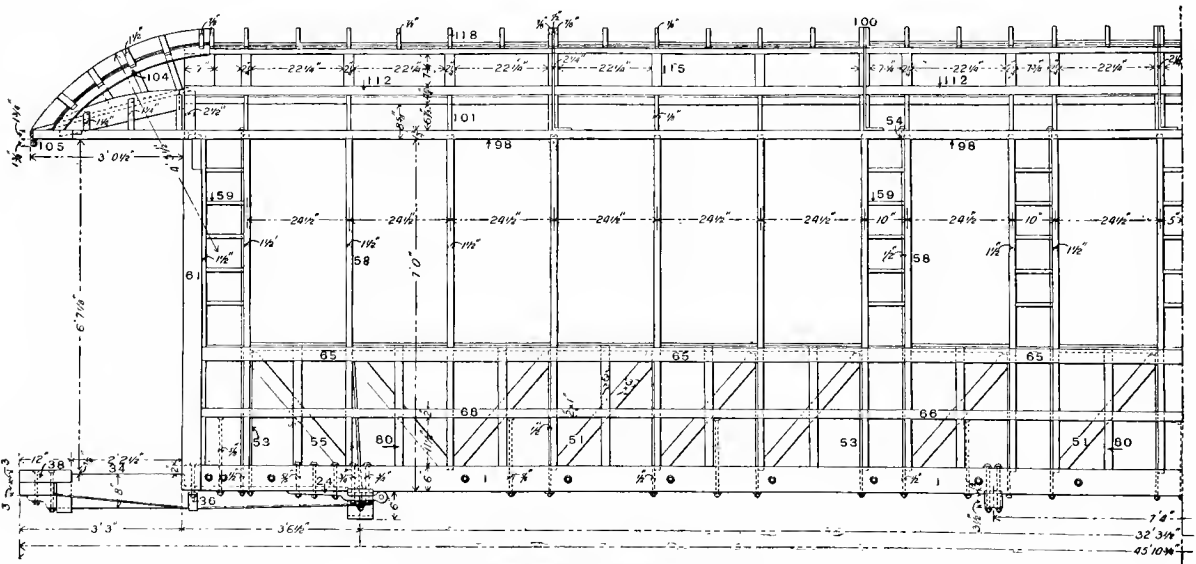

Fig. 462. Half Side Elevation of Framing.

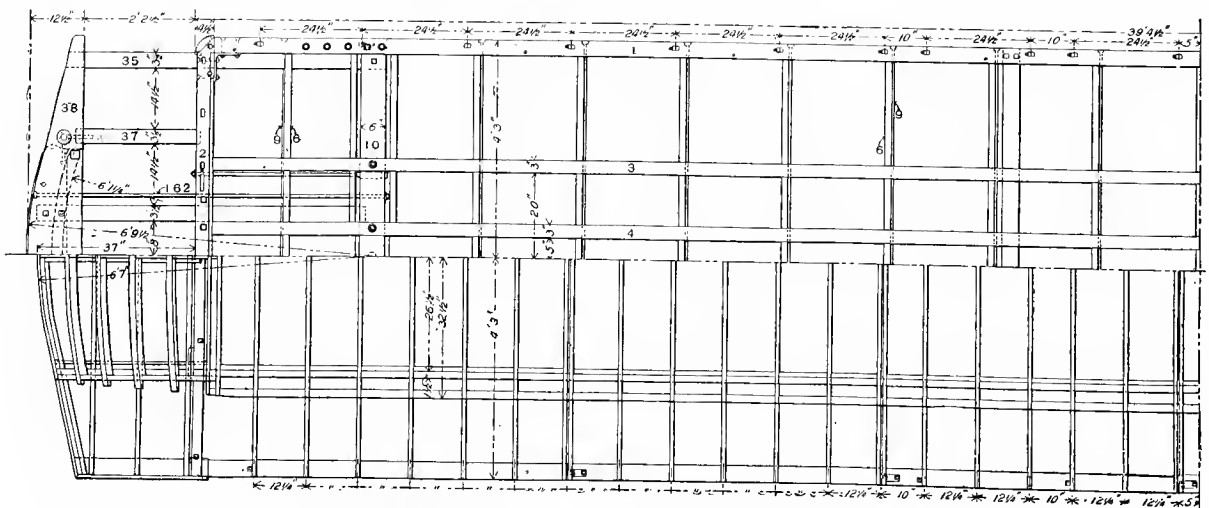

Fig. 463. Half Plan of Underframing and Roof Framing.

SUBURBAN PASSENGER CAR, MANHATTAN RAILWAY, NEW YORK CITY.

Numbers refer to List of Nsmes with Figs. 441-446.

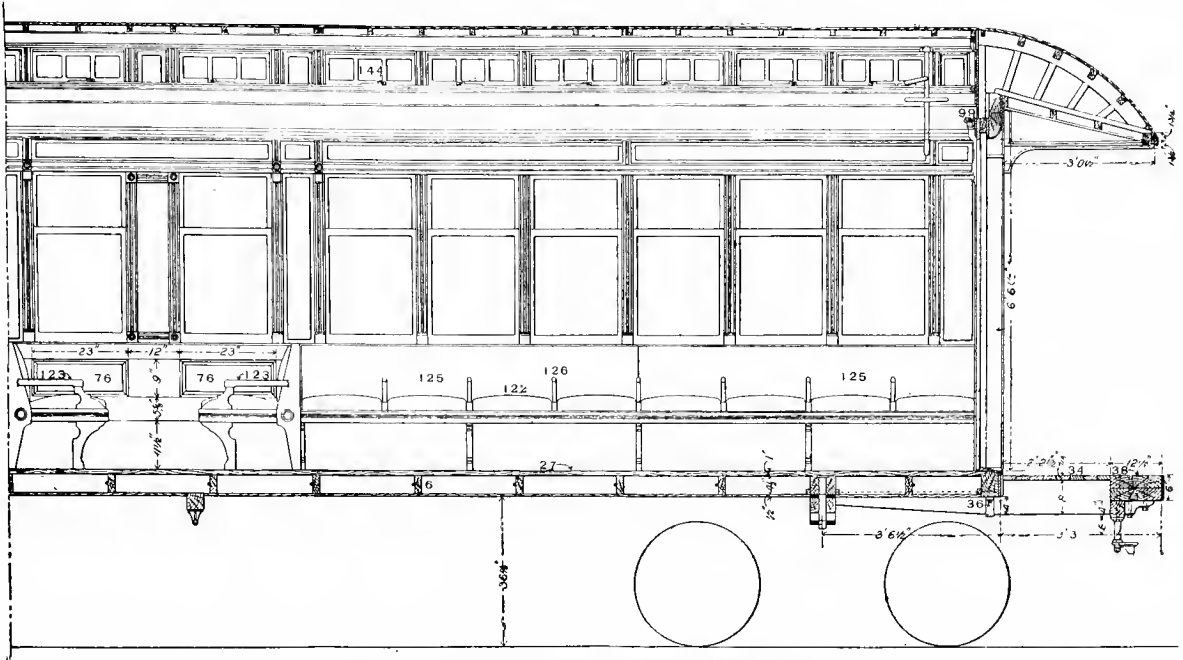

Fig. 464. Half Longitudinal Section, Showing Interior.

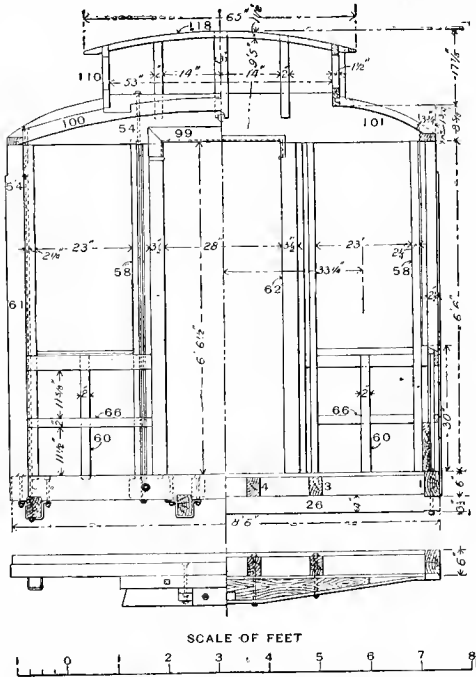

Fig. 465. End Elevation of Framing.

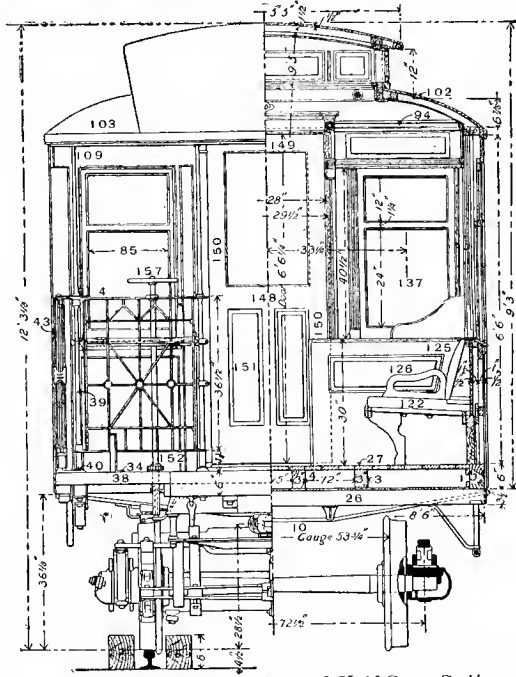

Fig. 466. Half End Elevation and Half Cross Section.

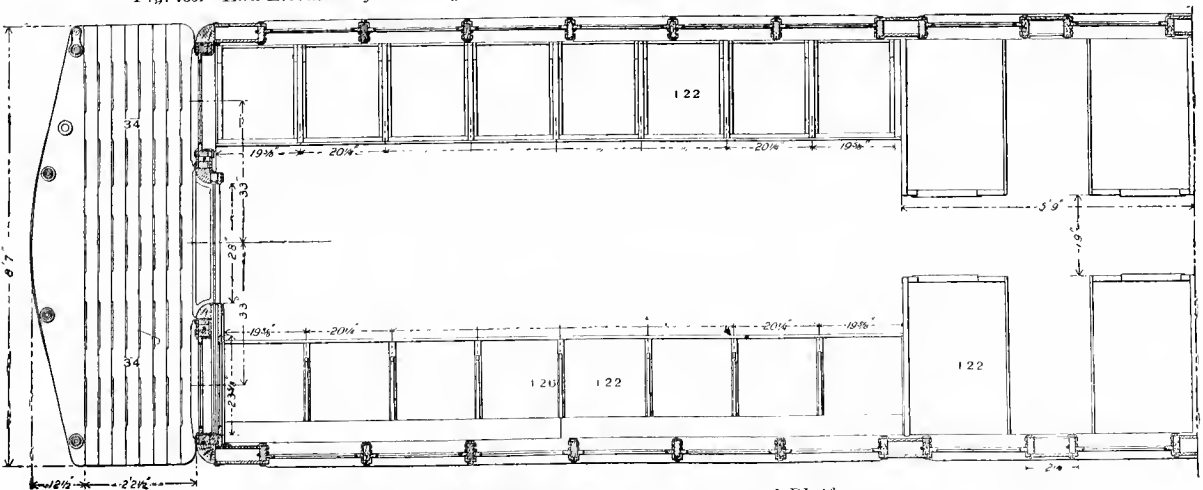

Fig. 467. Sectional Half Plan, Showing Seats and Platform.

SUBURBAN PASSENGER CAR. MANHATTAN RAILWAY, NEW YORK CITY.

Numbers Refer to List of Names with Figs. 441-446.

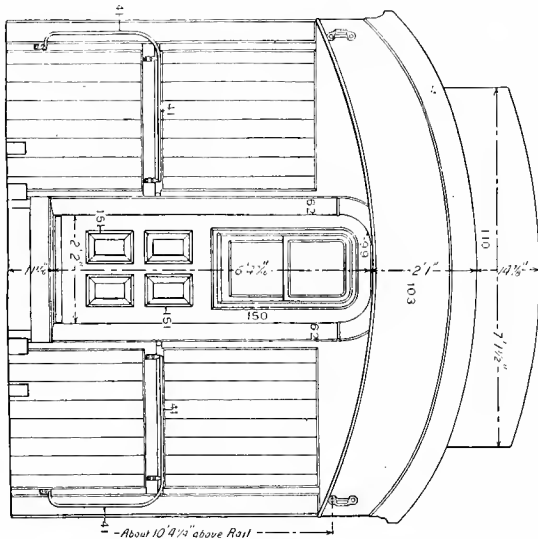

Fig. 469. End Elevation.

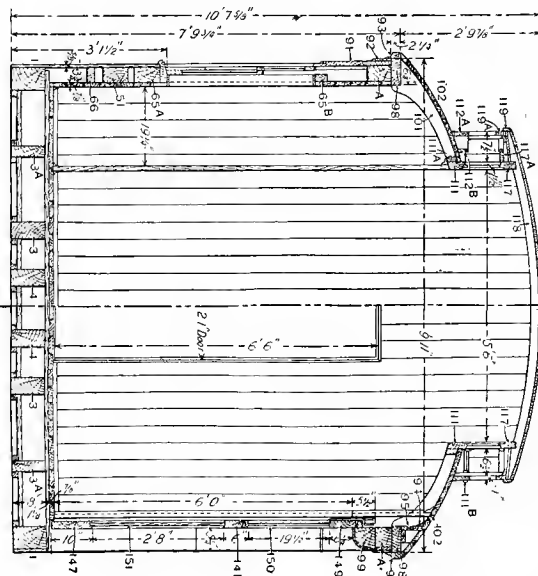

Fig. 470. Transverse Sections. COMBINATION BAGGAGE, MAIL AND SMOKING CAR. NEW YORK, LAKE ERIE & WESTERN RAILROAD.

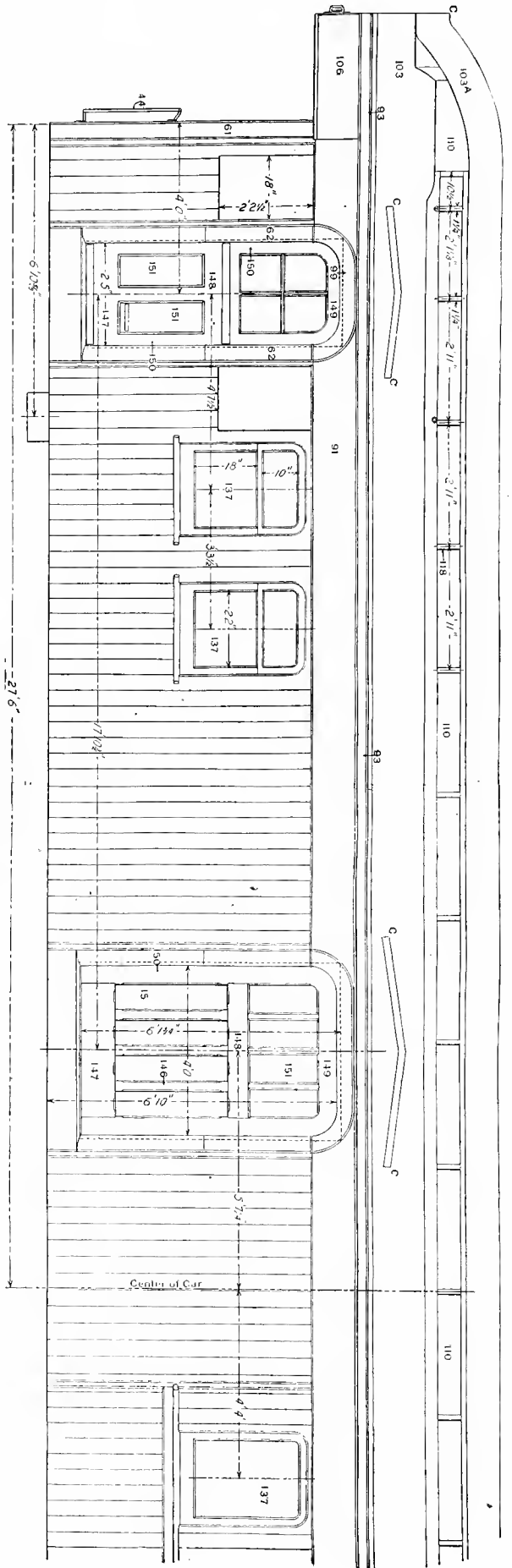

Fig. 468. Part Side Elevation.

SPECIAL LIST OF NUMBERS FOR Figs. 468-470.

- C. Water Dip.
- 4g. Same as 4f.
- 65a. Window-sill.
- 65b. Window-cup.
- 103a. Platform-hood.
- 111a. Deck-sill Re-enforcing-piece.
- 111b. Deck-sill Bolt.
- 112a. Deck-screen Bottom-rail.
- 112b. Distance Piece.
- 117a. Deck Soffit-board.
- 119. Deck Facia-board.
- 119a. Deck Sub-facia-board.

For Names of other Parts Numbered see List with Figs. 441-446.

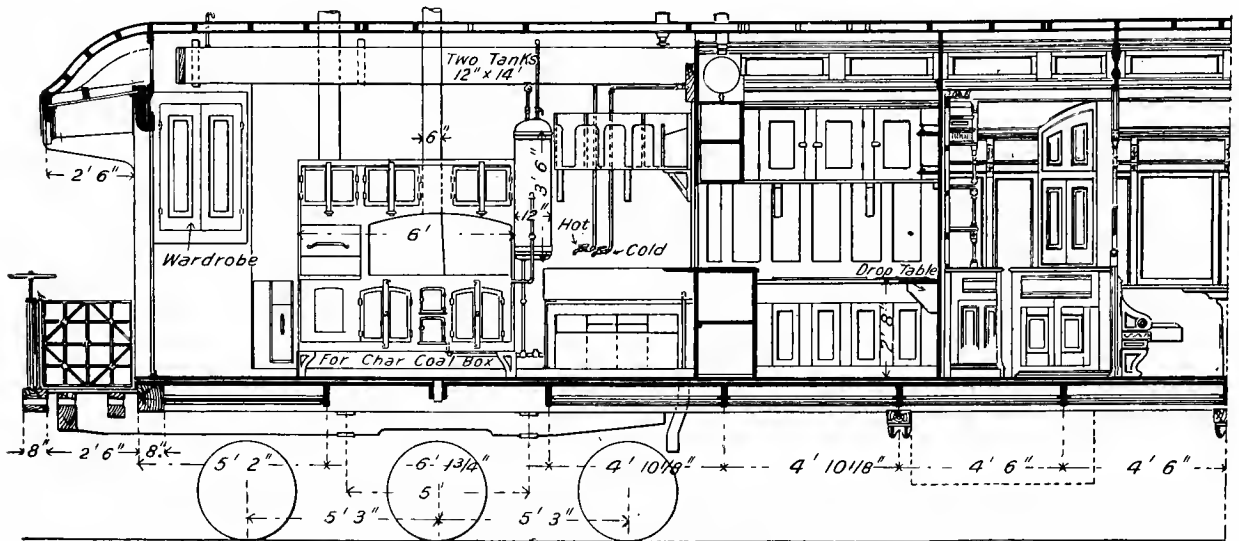

Fig. 474. Sectional Half Side Elevation.

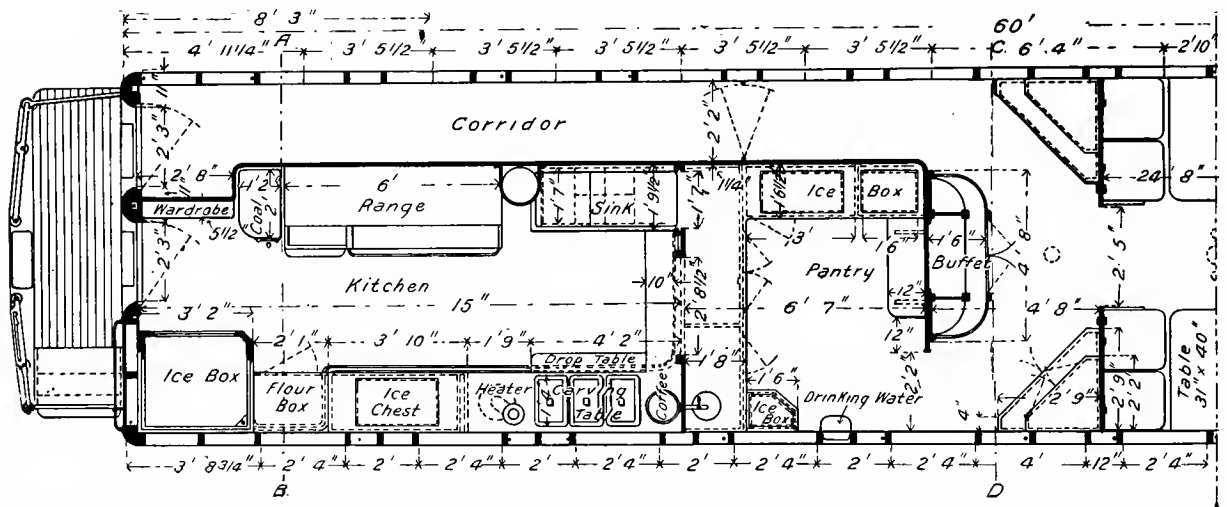

Fig. 475. Plan of Kitchen, Pantry and Buffet.

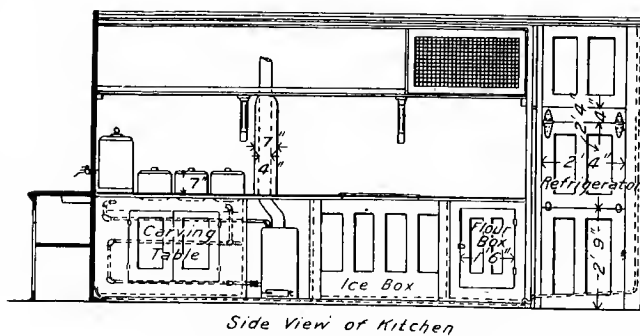

Fig. 476. Side Elevation of Kitchen.



Fig. 477. Refrigerator.

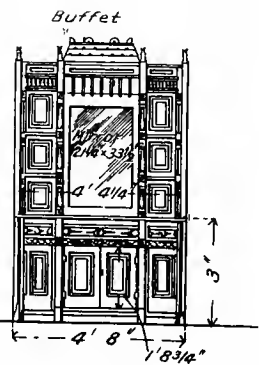

Fig. 478. Buffet.

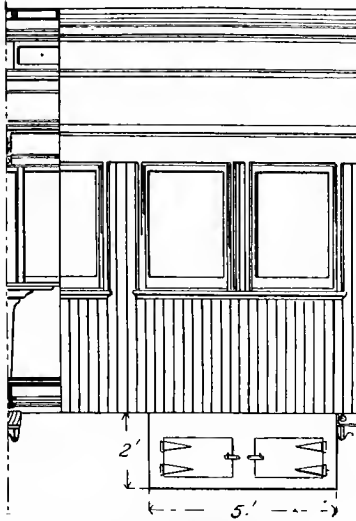

Fig. 479. Part Side Elevation.

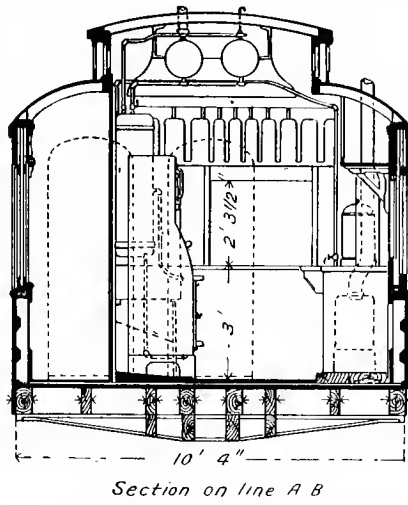
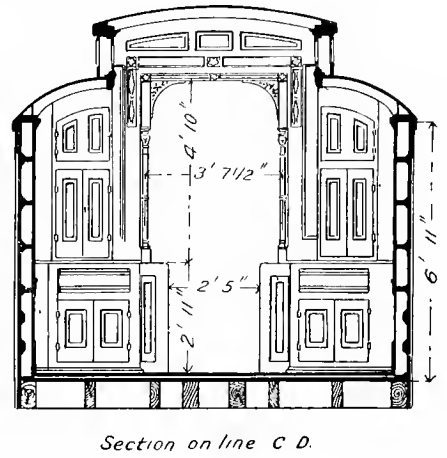

Fig. 480. Transverse Section showing Kitchen.



Section on line C D.

Fig. 481. Transverse Section showing Bulkhead.

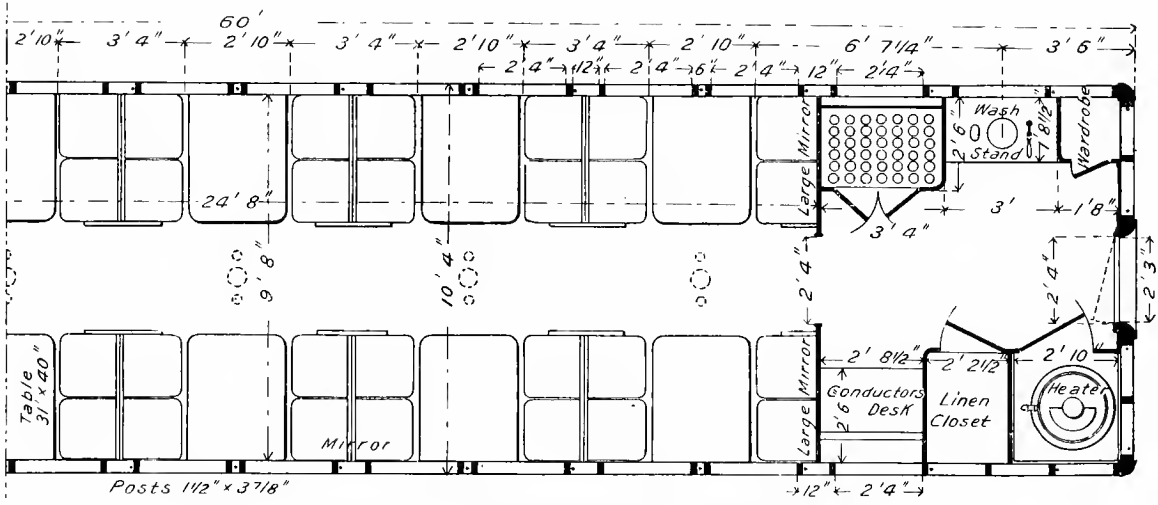
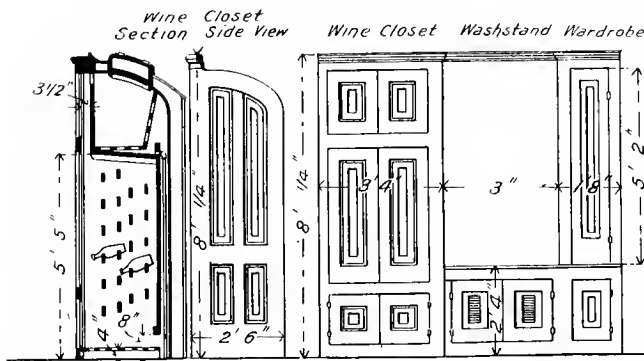

Fig. 482. Plan of Dining Room and Conductor's Quarters.



Figs. 483 and 484. Wine Closet.

Fig. 485. Side Elevation of Conductor's Quarters.

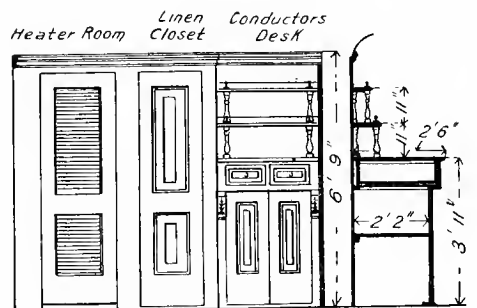

Fig. 486. Side Elevation of Conductor's Quarters.

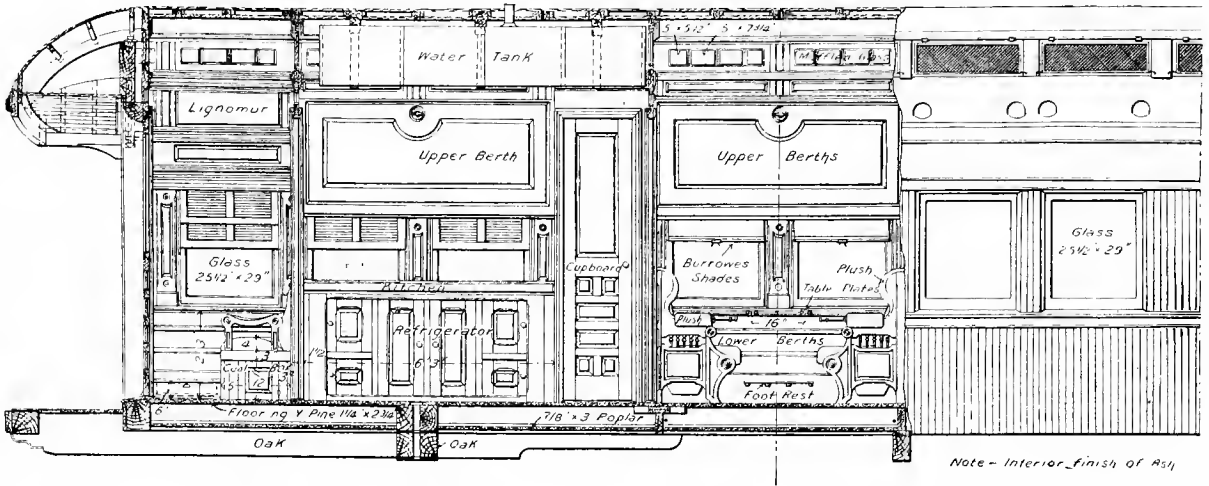

Fig. 487. Part Longitudinal Section and Part Side Elevation

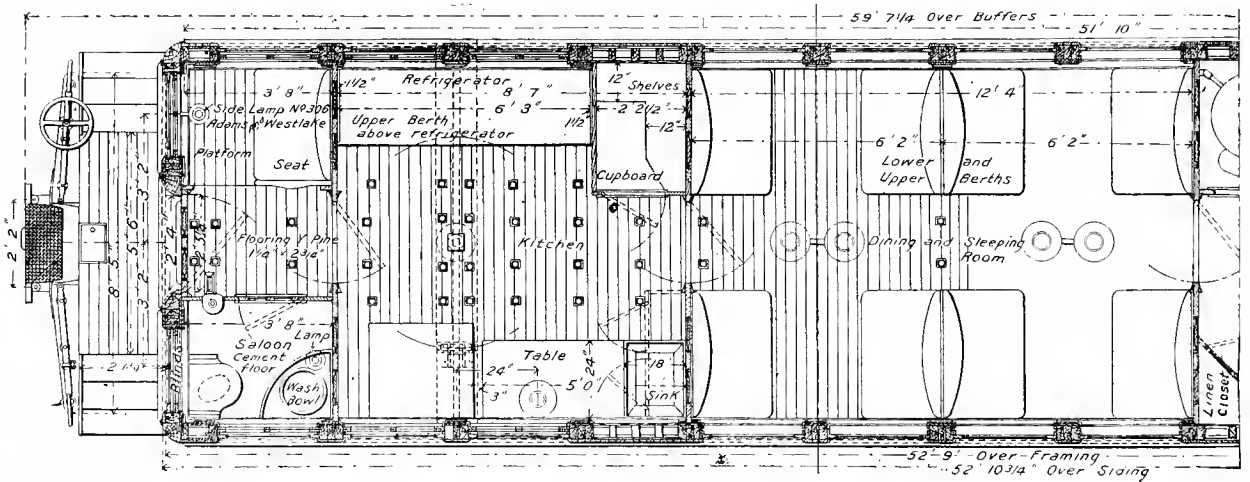

Fig. 488. Sectional Plan of Floor.

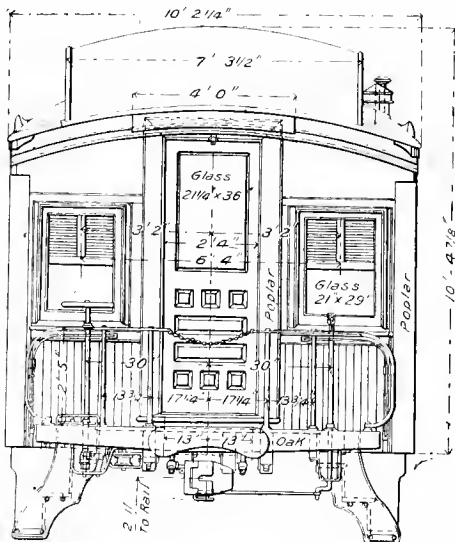

Fig. 489. End Elevation.

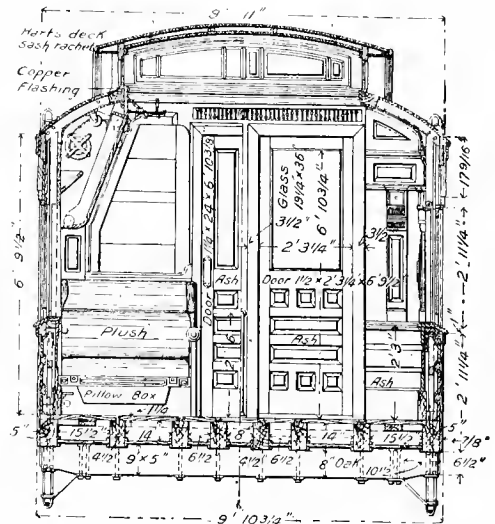

Fig. 490. Transverse Section.

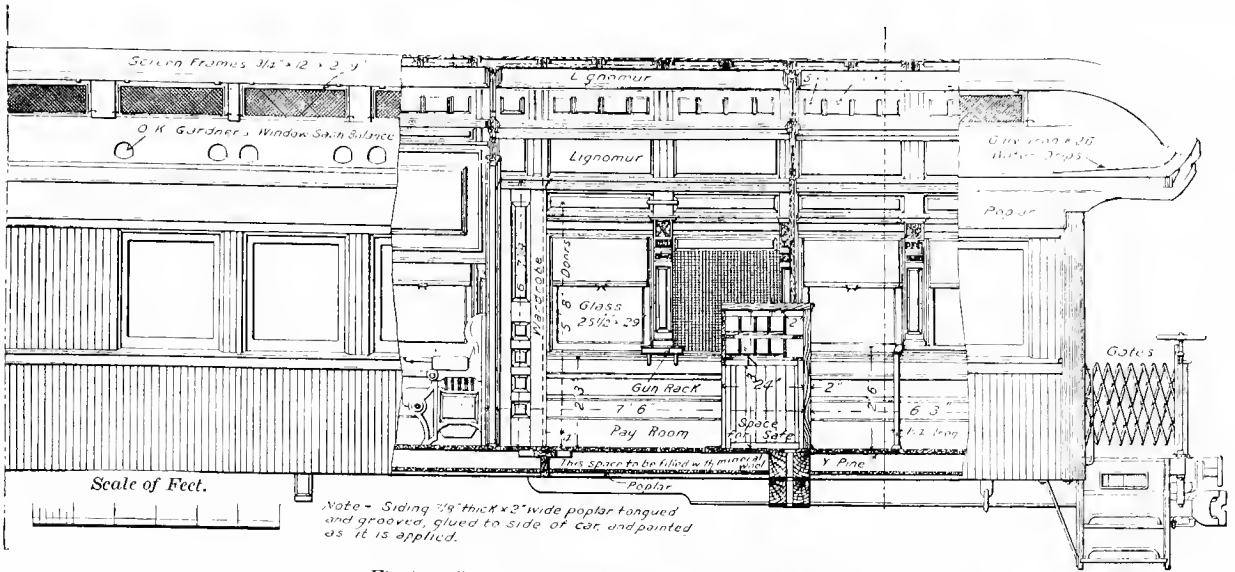

Fig. 491. Part Elevation and Part Longitudinal Section.

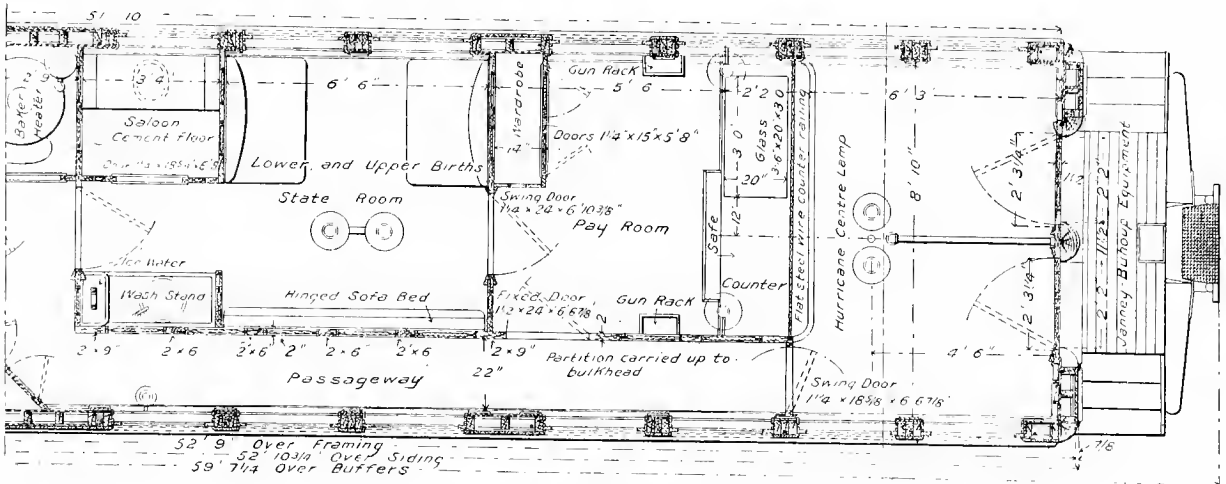

Fig. 492. Sectional Plan of Floor.

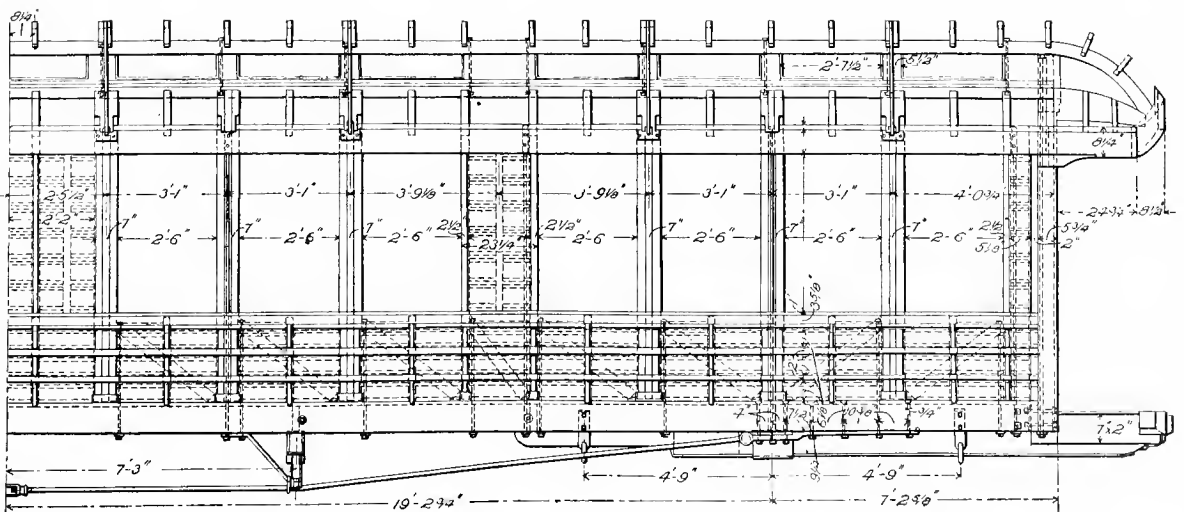
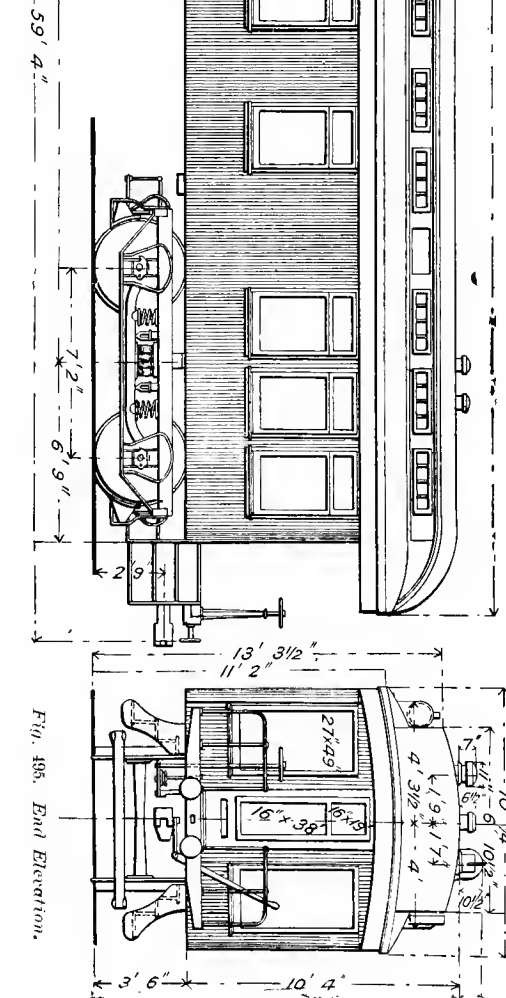
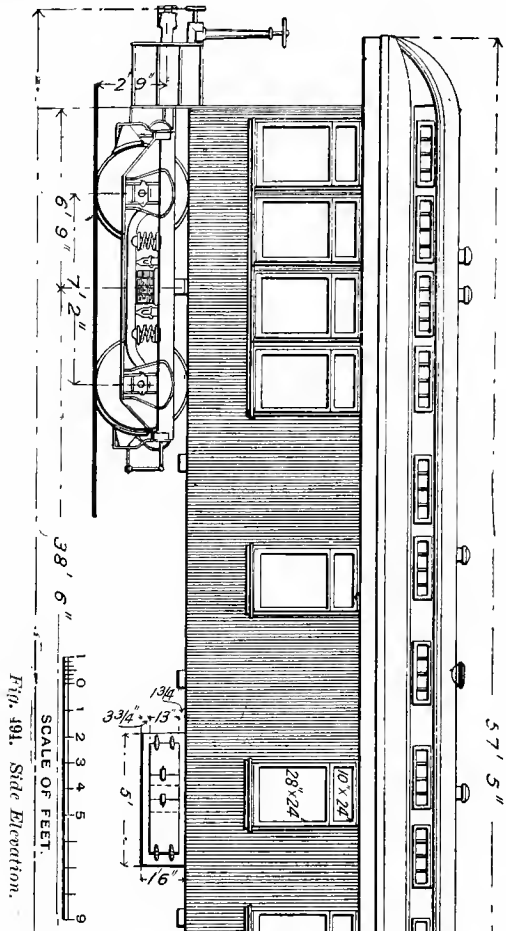
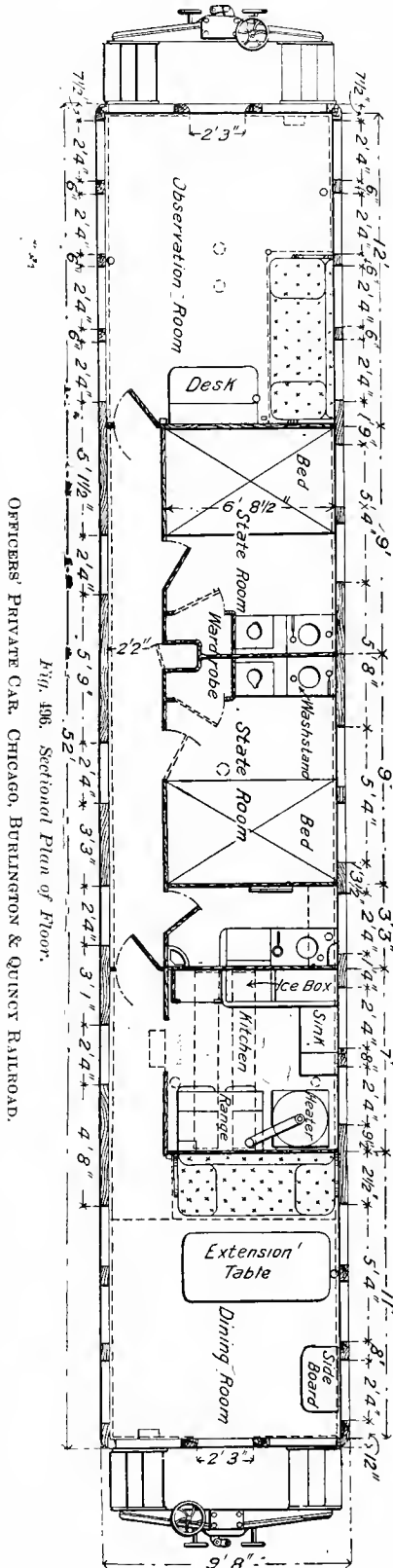

Fig. 493. Half Side Elevation of Framing.



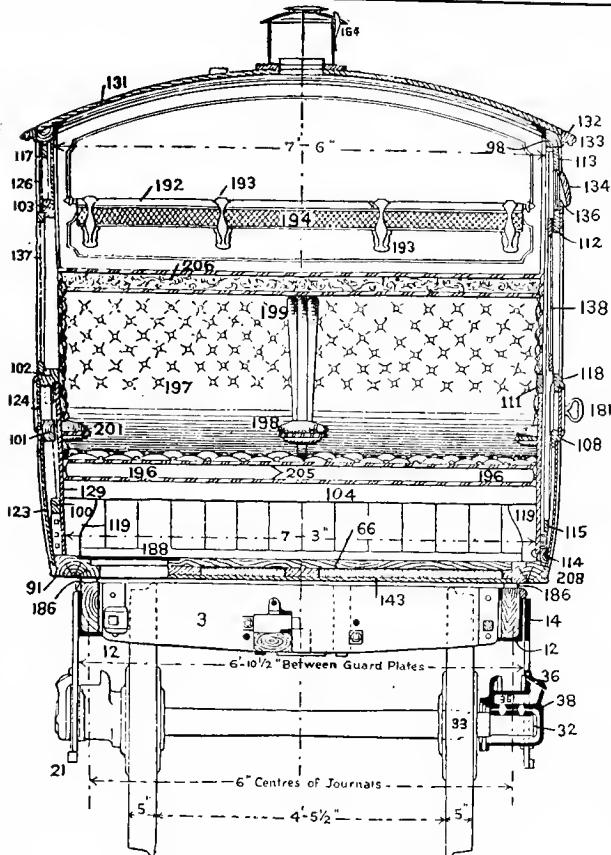

Fig. 503. Transverse Section.

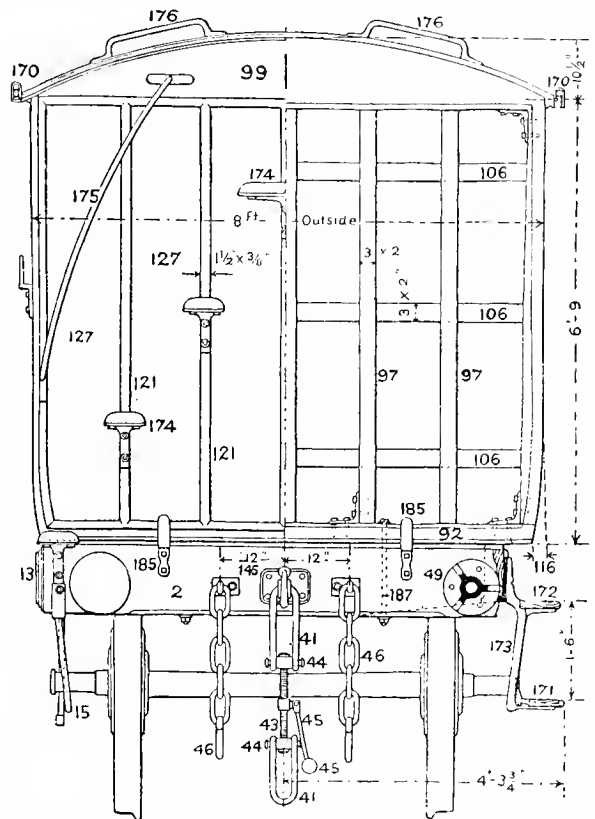

Fig. 504. End Elevation.

NAMES OF PARTS OF ENGLISH FIRST-CLASS CARRIAGE, Figs. 501-504.

- | | | | |
|---|--|--|---|
| 1. Solebar. | 46. Safety Chain, or Side Chain, consisting of Eye-bolt, Chain and Hook. | 109. Door-panel batten. | 143. Outer Double Floor, or Floor Underlining. |
| 2. Headstock, or Buffer Beam. | 47. Buffer-head. | 110. Quarterlight Pillar. | 144. Bottom-side and End Knee. |
| 3. Cross-bearer, Crossbar, or Transome. | 48. Buffer-rod. | 111. Door Garnish-rail. | 145. Draw-hook Washer, or Drawbar Front-plate. |
| 4. Diagonal. | 49. Buffer-rod Guide, or Buffer Block. | 112. Door Bottom Ventilator-rail. | 146. Draw-spring Cradle-plate. |
| 5. Middle Longitudinal. | 50. Buffer-rod Shoe. | 113. Door Top-rail. | 150. Seat-board. |
| 6. End Half-longitudinal. | 51. Plate, or Laminated Buffering and Draw-spring. | 114. Door Bottom-rail. | 151. Cushion Back-rail. |
| 7. Brake-shaft Cross-bearer, or Center Crossbar. | 52. Auxiliary Draw-spring (rubber). | 115. Door Glass-frame Stop-rail. | 152. Back Seat Rail. |
| 8. Buffering-spring Bed, or Back Chock. | 66. Floor Board, or Floor Batten. | 116. Fall-under, or Turn-under. | 160. Lamp Case. |
| 9. Longitudinal Tie rod. | 83. Headstock and Diagonal Knee. | 117. Side Top-panel Rail. | 161. Lamp-cover, or Lamp Protector. |
| 10. Transverse Tie-rod. | 84. Spring-link, or Spring Shuckle. | 118. Door Fence-rail. | 162. Lamp-plug. |
| 11. Strap Bolt. | 85. Spring-link Adjusting-screw, or Tee-bolt. | 119. Seat-rail Support. | 163. Lamp-plug Stand. |
| 12. Solebar Angle-iron. | 86. Spring-link Adjusting-screw (special pattern). | 120. Roof-stick, or Hoop-stick. | 164. Lamp-cover Spring-catch. |
| 13. Headstock Cap (cast iron). | 87. Auxiliary Rubber Bearing-spring. | 121. Planted Moulding, or Bead Moulding. | 165. Lamp-burner. |
| 14. Axle-guard (plate pattern), or Hornplate. | 88. Scroll-iron, or Spring Hanger. | 122. Wrought Moulding, or Fascia Moulding. | 166. Lamp-glass. |
| 15. Axle-guard Stay-rod, or Axle-guard Stretcher. | 89. End Scroll-iron. | 123. Bottom Side-panel. | 167. Lamp-case Base, or Packing. |
| 16. Spider Plate (plain), or Underframe Plate. | 90. Scroll-iron (special pattern). | 124. Waist-panel. | 168. Inner Lamp-ring. |
| 21. Axle-guard Keep, Horn-stay, or Bridle. | 91. Bottom-side. | 125. Quarter-panel. | 170. Communication-cord Pulley. |
| 22. Bearing-spring. | 92. Bottom End-piece, or Bottom End-bar. | 126. Quarterlight-panel. | 171. Lower Foot-board. |
| 23. Bearing spring Buckle, or Hoop. | 93. Bottom Cross-piece, or Bottom Crossbar. | 127. End-panel. | 172. Upper Foot-board (continuous). |
| 31. Journal. | 94. Corner-pillar. | 128. Bottom Door-panel. | 173. Step-iron, or Leg-iron. |
| 32. Collar, of Journal. | 95. Standing, Intermediate, or Partition Pillar. | 129. Inside Casing, or Inside Lining. | 174. End Ascending-step. |
| 33. Wheel-seat. | 96. Doorway Pillar. | 130. Partition. | 175. End Ascending-rail. |
| 34. Grease Axle-box. | 97. End Pillar. | 131. Roof-board. | 176. Roof Ascending rail, or Roof Commode-handle. |
| 35. Grease Chamber. | 98. Cant-rail. | 132. Side-gutter, or Outside Cornice. | 177. Commode-handle. |
| 36. Axle-box Cover, or Lid. | 99. End Arch-rail. | 133. Side-gutter, or Outside Cornice Moulding. | 178. Upper Door-hinge. |
| 37. Axle-box Keep. | 100. Waist-rail. | 134. Ventilator Hood, or Cowl. | 179. Center Door-hinge and Stop (Cross' Patent). |
| 38. Axle-box Bearings, or Brass. | 101. Elbow-rail. | 135. Ventilator Sliding-panel. | 180. Lower Door-hinge. |
| 39. Drawbar. | 102. Bottom Light-rail. | 136. Ventilator Fixed-panel. | 181. Door-handle. |
| 40. Draw-hook. | 103. Top Light-rail. | 137. Quarterlight, or Side-light (fixed). | 182. Private Lock. |
| 41. Coupling Shackle. | 104. Front Seat-rail. | 138. Door-light (falling). | 183. Destination-board Bracket. |
| 43. Coupling Screw. | 105. Bottom Panel-batten. | 139. Door Pillar or Door-Style. | 184. Side Lamp-iron. |
| 44. Screw-Coupling, Nut and Gudgeons. | 106. End-rail. | 140. Door-light Bottom Sash-rail, or Glass-frame Bottom Sash-rail. | 185. End Lamp-iron. |
| 45. Screw-coupling Weighted Lever. | 107. Top Panel-batten. | 141. Door-light Stile, or Glass-frame Stile. | 186. India-rubber Body-cushion, or Attock's Body-block. |
| 41-45. Screw coupling, consisting of Shackle, Screw, Nuts and Weighted Lever. | 108. Elbow-rail. | 142. Quarterlight Moulding, or Glass-frame Stile. | 187. Body Holding-down Bolt. |

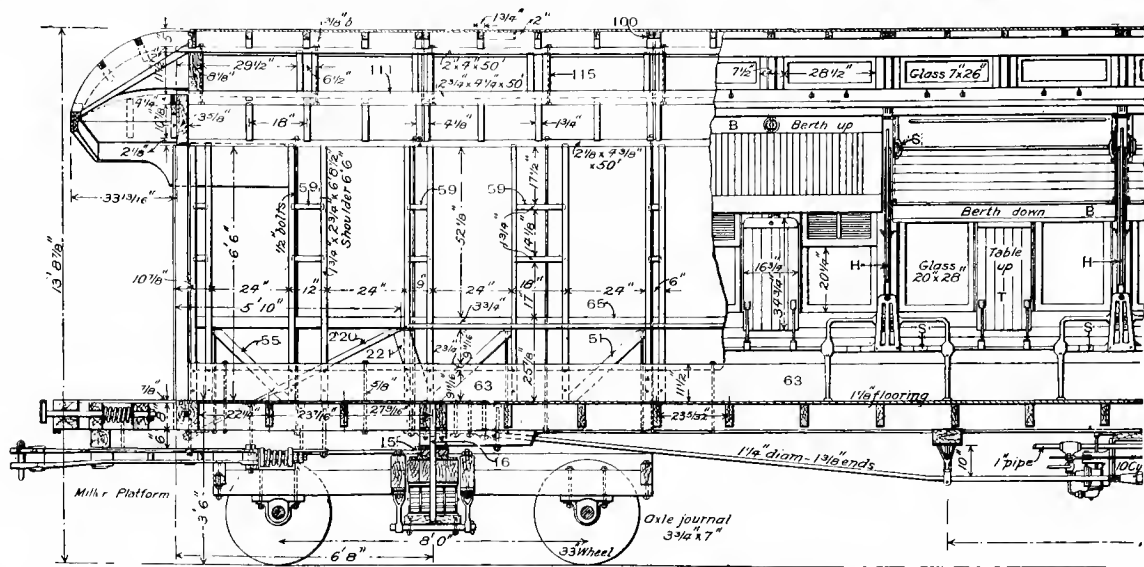

Fig. 505. Half Longitudinal Section Showing Framing and Interior.

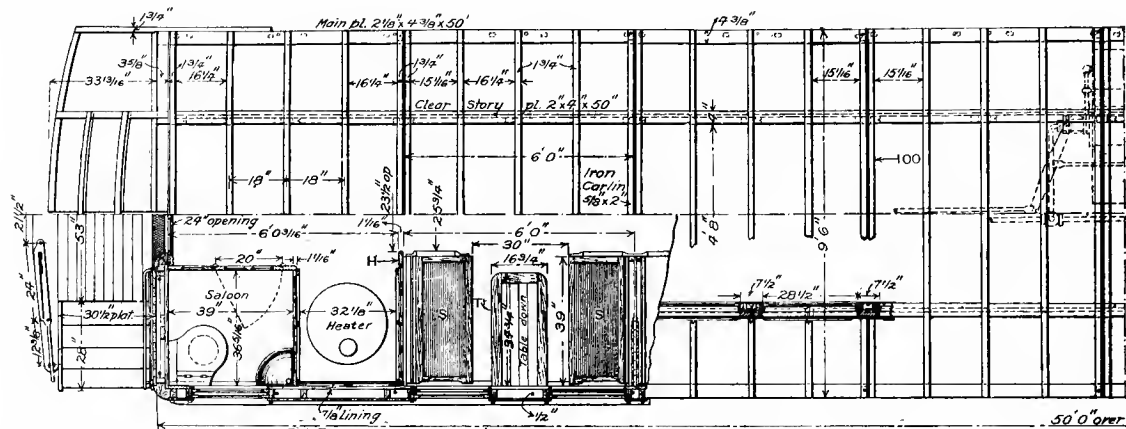

Fig. 506. Half Plan Showing Seats and Roof Framing.

NAMES OF PARTS, Figs. 505-511.

- | | |
|--|------------------------------------|
| 1. Side-sill. | 46. Tread-board. |
| 2. End-sill. | 51. Brace. |
| 3. Intermediate-sill. | 55. Counter-brace. |
| 4. Center-sill. | 59. Sheathing Furring. |
| 6. Bridging. B. Upper Berth. | 63. Truss-plank. |
| 9. Sill Tie-rod. | 65. Belt-rail. |
| 15. Body Center-plate. | 98. Plate. |
| 16. King-bolt. | 100. Carline. |
| 27. Floor. H. Head Board. | 102. Roof-boards. |
| 28. Drawbar. | 110. Clear-story or Upper-deck. |
| 35. Platform-sills. | 111. Deck-sill. |
| 37. Platform Short-sills. | 115. Deck-post. |
| 39. Platform Railing-post. | 116. Deck End-panel or Ventilator. |
| 40. Base-washer for Platform Railing-post. | 117. Deck plate. |
| 41. Platform-rail. | 118. Upper-deck Carline. |
| 44. Body Hand-rail. S. Seat. | 220. Overhang Truss-rod. |
| 45. Platform-step. T. Table. | 221. Overhang Truss-rod Strut. |

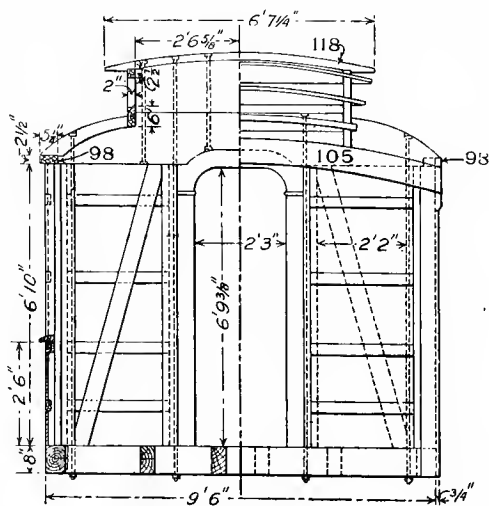

Fig. 507. End Elevation of Framing.

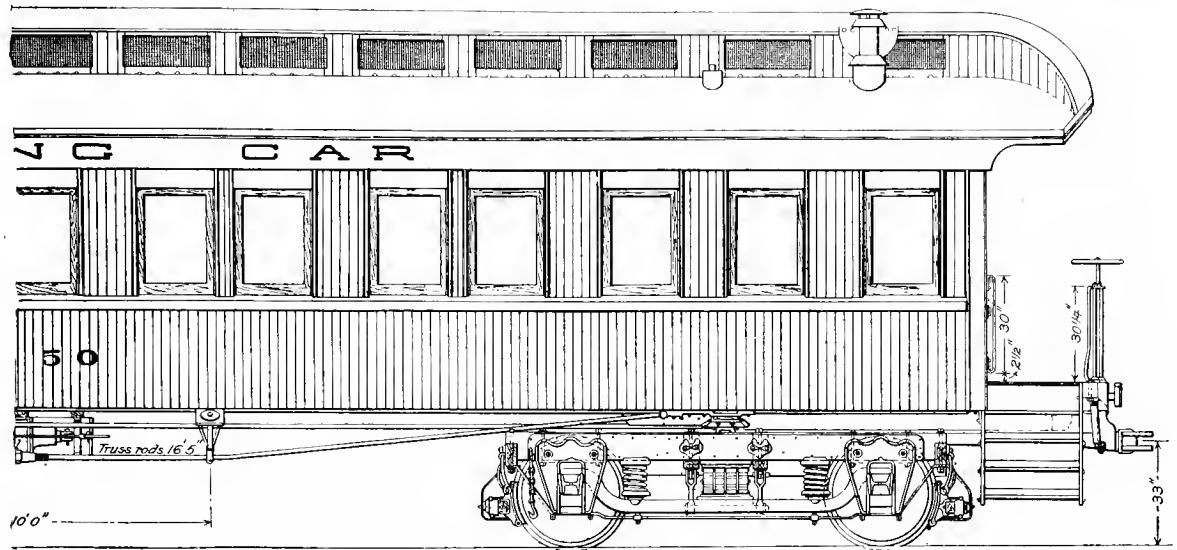

Fig. 508. Half Side Elevation.

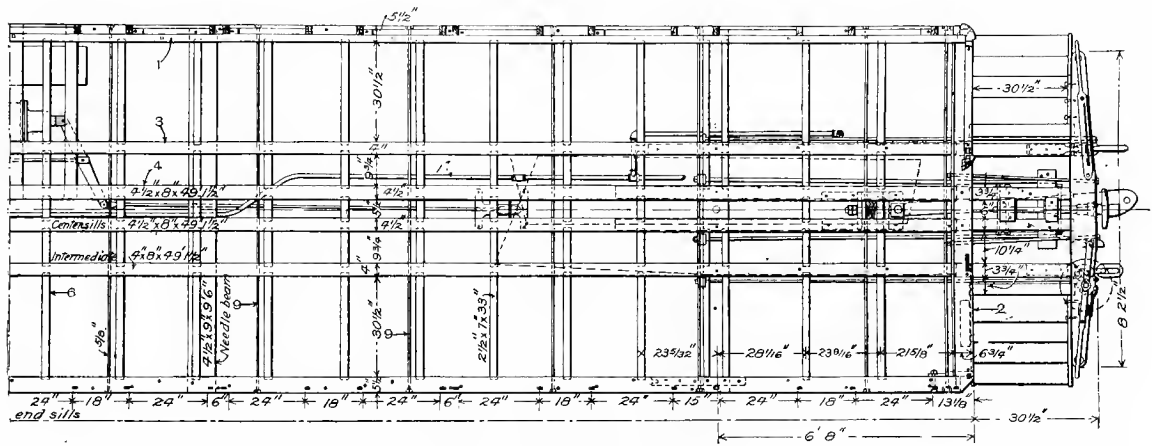

Fig. 509. Half Plan of Underframe.

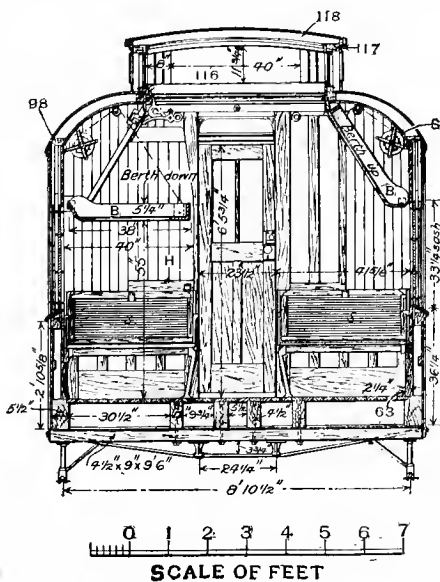

Fig. 510. Transverse Section Showing Seats and Berths.

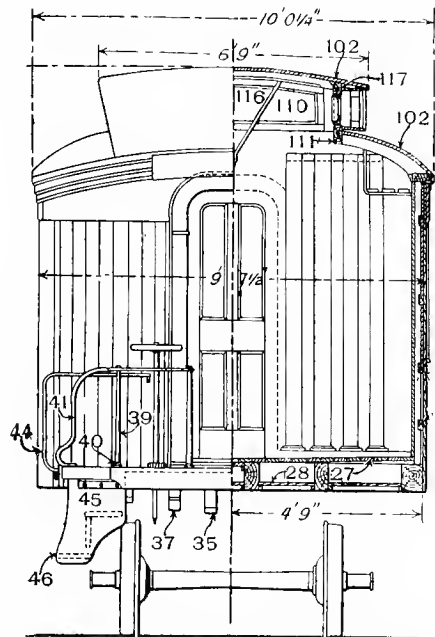

Fig. 511. End Elevation and Cross Section.

EMIGRANT OR TOURIST'S SLEEPING CAR. SOUTHERN PACIFIC COMPANY.

NAMES OF PARTS, Figs. 512-518.

- 1. Side-sill.
- 2. End-sill.
- 3. Intermediate-sill.
- 4. Center-sill.
- 8. Sill Knee-iron.
- 20. Body Truss-rod.
- 22. Cross Tie-timber.
- 35. Platform-sills.
- 51. Brace.
- 54. Sill-and-plate Rod.
- 55. Counterbrace.
- 58. Window-post.
- 59. Pier Panel-furring.
- 60. Stud.
- 61. Corner-post.
- 63. Truss-plank.
- 98. Plate.
- 101. Rafter.
- 103. Platform-roof.
- 104. Platform-roof Carline.
- 105. Platform-roof End-carline.
- 106. Roof-apron.
- 111. Deck-sill.
- 117. Deck-plate.
- 118. Upper-deck Carline.
- 119. Upper-deck Window-frame.

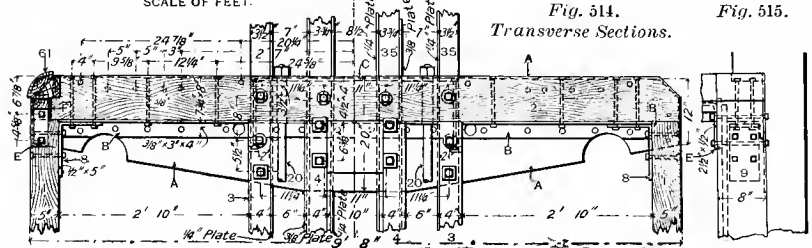
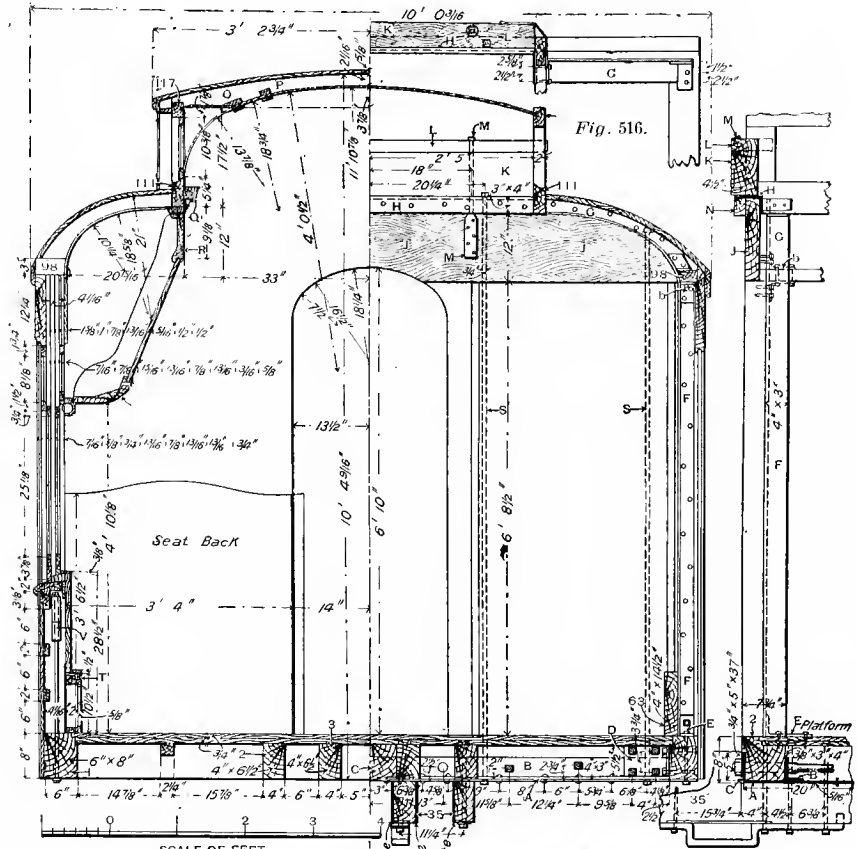
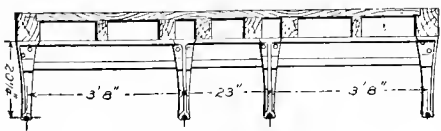

Fig. 517. Sectional Plan.

Fig. 518. Corner.

STANDARD END FRAMING FOR PARLOR, PRIVATE AND SLEEPING CARS.
 PULLMAN'S PALACE CAR COMPANY.
 (Showing Anti-Telescoping Device.)



Section on center line
519

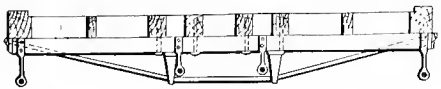

Section on line A A
520



Section on line B B
521



Section on line C C
522

Figs. 519-522, CROSS SECTIONS OF UNDERFRAME FOR SLEEPING AND PRIVATE CARS.
 PULLMAN'S PALACE CAR COMPANY.
 (Steel Needle-beams.)

NAMES OF PARTS, Figs. 514-518.

- A. End sill Stiffening-plate.
- B. End-sill Stiffening-angle.
- b. Iron Carline Knee-iron.
- C. Truss-rod Washer-plate.
- D. Sill Knee-iron.
- E. Corner-post Knee-iron.
- F. Corner Angle-post.
- G. Iron-carline or Rafter.
- H. End-plate Strengthening-angle.
- J. Body End-plate.
- K. Deck End-plate.
- L. Corner-plate.
- M. Deck End-plate Strap-bolt.
- N. Platform-roof Carline.
- O. Ceiling-furring.
- P. Ceiling-furring
- Q. Inside Upper Deck-cornice.
- R. Berth-front, Upper-part.
- S. End Sill-and-plate Tie-rod.
- V. Side Cantilever-truss for Overhang.

Fig. 523-526. CAR-BODIES, Passenger; Framing for Sleeping Cars.

Fig. 525. End Elevation and Cross Section.

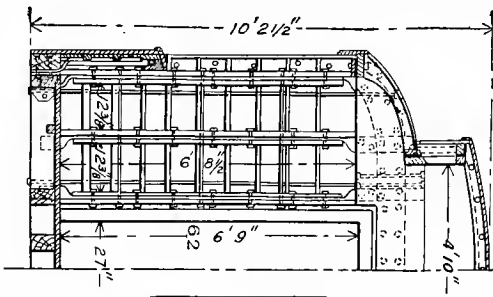

Fig. 523. Longitudinal Section of End.

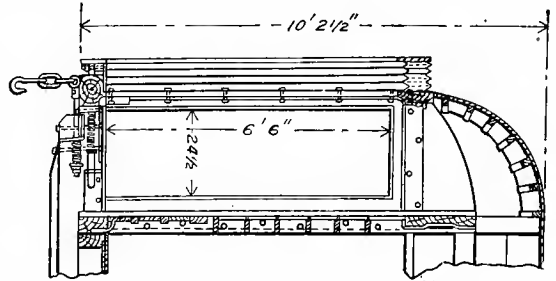
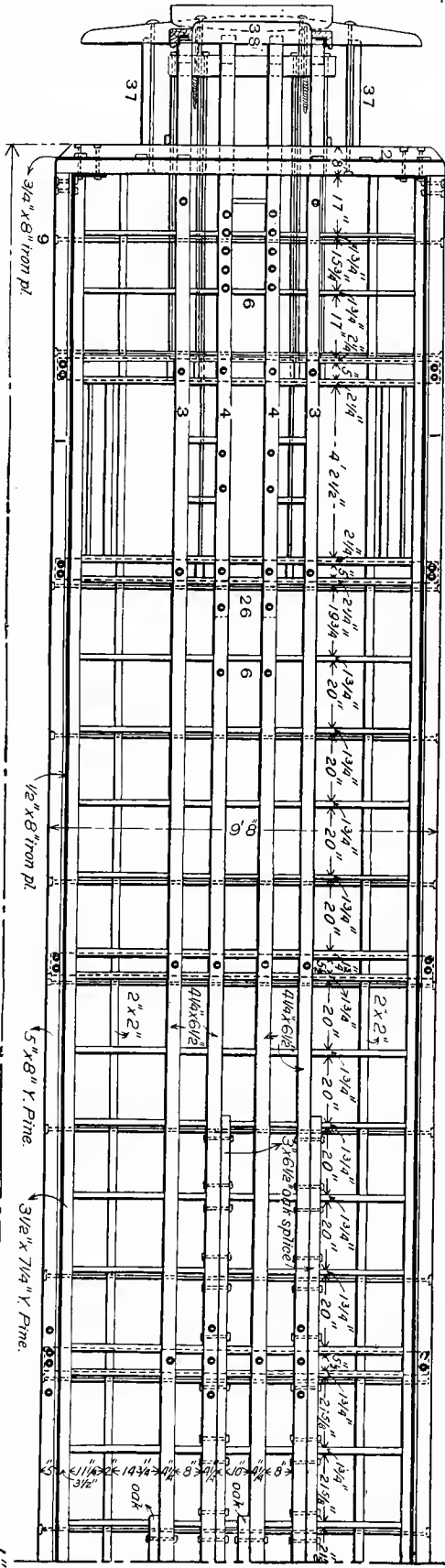
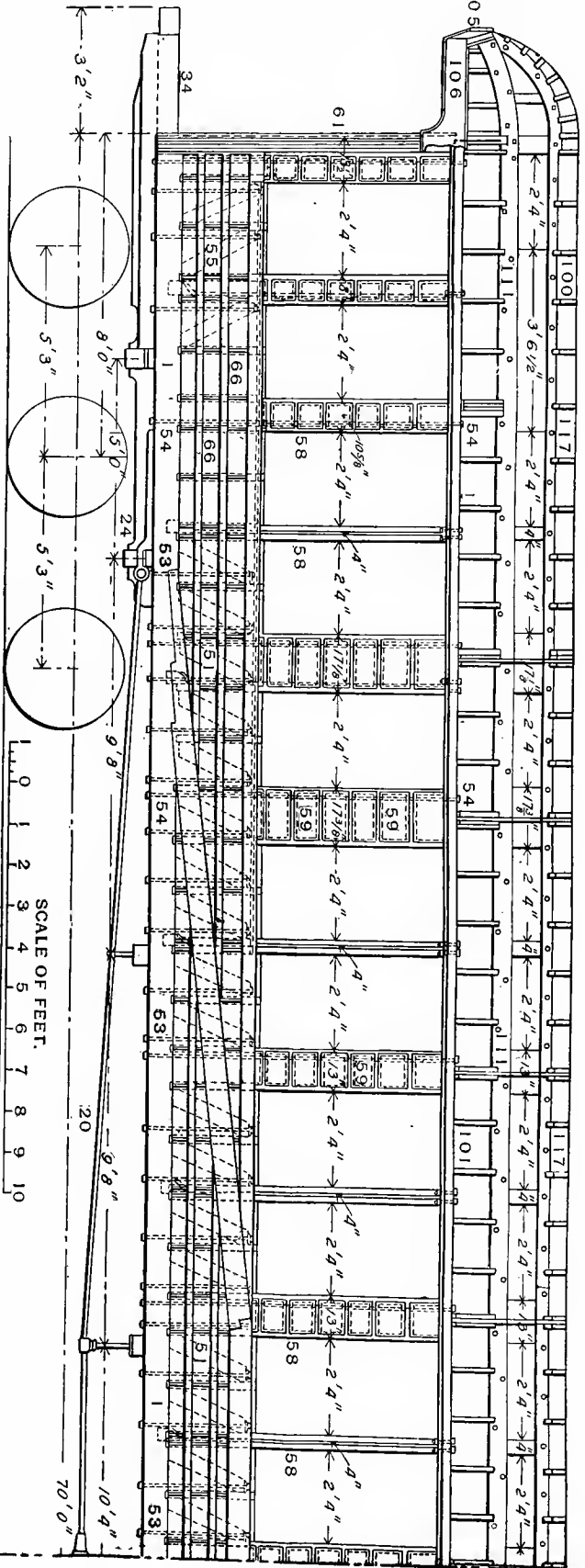

Fig. 526. Half Plan of Underframe.



STANDARD FRAMING FOR PARLOR, PRIVATE AND SLEEPING CARS. WAGNER PALACE CAR COMPANY.

Fig. 534. Half Side Elevation of Framing.



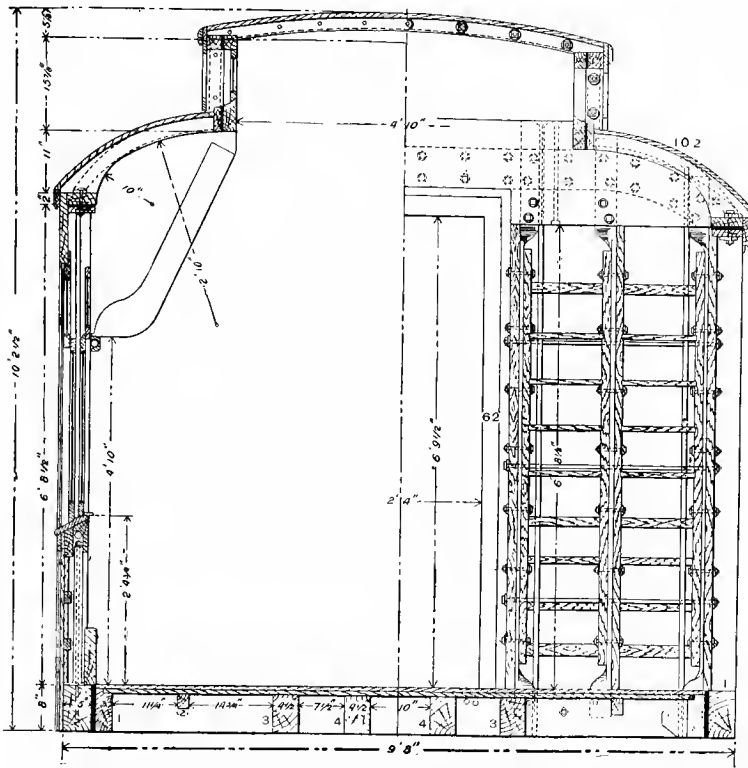

Fig. 527. Half Cross Section and Half End Elevation.

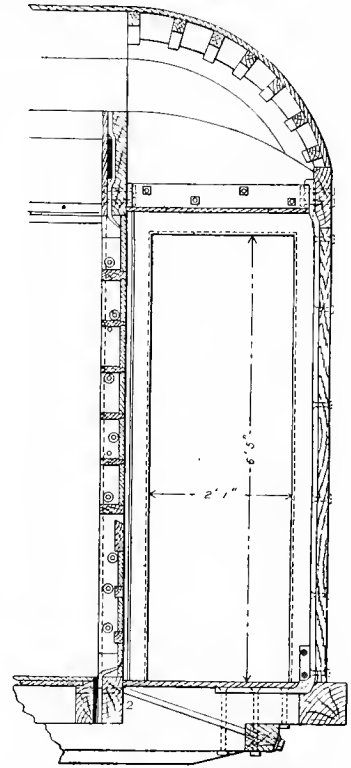
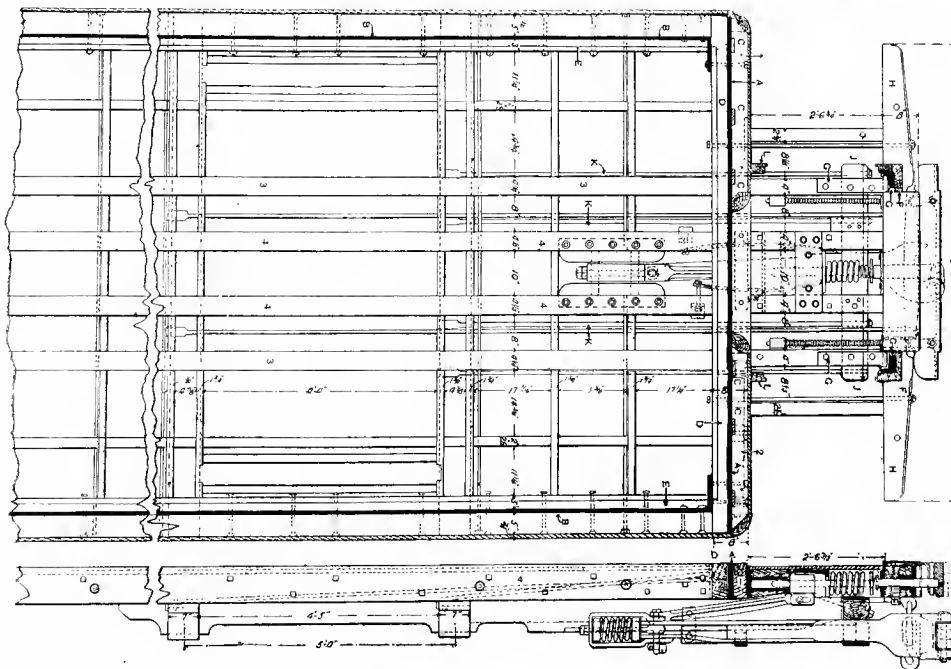

Fig. 528. Section of Vestibule.



Figs. 529-530. Plan and Side Elevation of Platform and Car End.

STANDARD COMPOSITE END FRAMING FOR PARLOR, PRIVATE AND SLEEPING CARS.
WAGNER PALACE CAR COMPANY.

NAMES OF PARTS. Figs. 523-530.

- | | | | |
|-----------------------------|---------------------------------|------------------------------------|--|
| 1. Side-sill. | 51. Brace. | 101. Rafter. | D. End-sill Fitch-plank. |
| 2. End-sill. | 53. Sill-and-belt-rail Tie-rod. | 102. Roof Boards. | E. Side-sill Fitch-plank. |
| 3. Intermediate-sill. | 54. Sill-and-plate Tie-rod. | 105. Platform-roof End-carline. | F. Vestibule Composite End-post. |
| 4. Center-sill. | 55. Counterbrace. | 106. Platform-roof Apron. | G. Foot of Iron Bar of Vestibule End-post. |
| 6. Bridging. | 58. Window-post. | 111. Deck-sill. | H. Platform End-sill. |
| 9. Sill Tie-rod. | 59. Window Sheathing Furring. | 117. Deck-plate. | J. Platform Cross-timber. |
| 20. Body Truss-rod. | 61. Corner-post. | A. End-sill Fitch-plate. | K. Platform Tie-rods. |
| 24. Truss-rod Anchor-strap. | 62. Door-post. | B. Side-sill Fitch plate. | L. Vestibule Body-corner-posts. |
| 26. Draft-timbers. | 66. Sheathing-strips. | C. Iron Bar of Composite End-post. | |
| 34. Platform. | 100. Upper-deck Carlines. | | |
| 37. Platform Short-sill. | | | |
| 38. Platform End-sill. | | | |

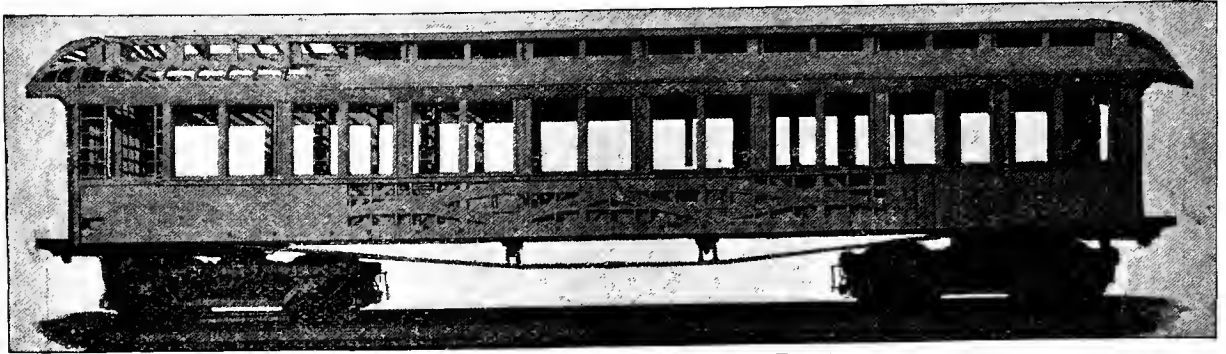

Fig. 531. *Side View, showing Truss and Roof Framing.*

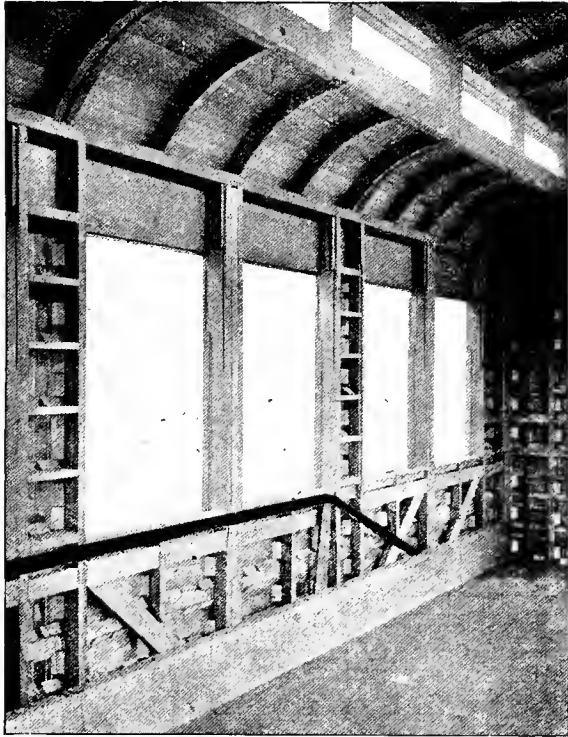

Fig. 532. *Interior View, showing Blocking and Overhang Truss-rod and Strut.*

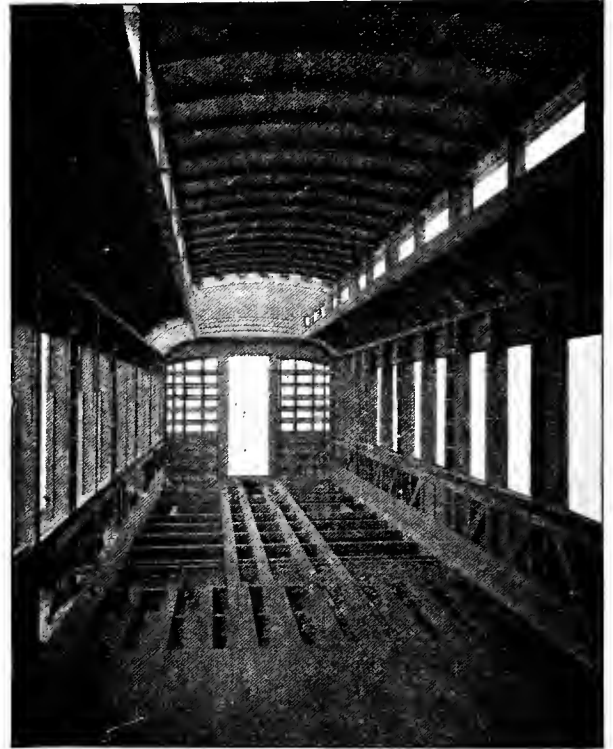

Fig. 533. *Interior View, showing Sills, Bridging, Truss-plank, Trussing and Superstructure.*

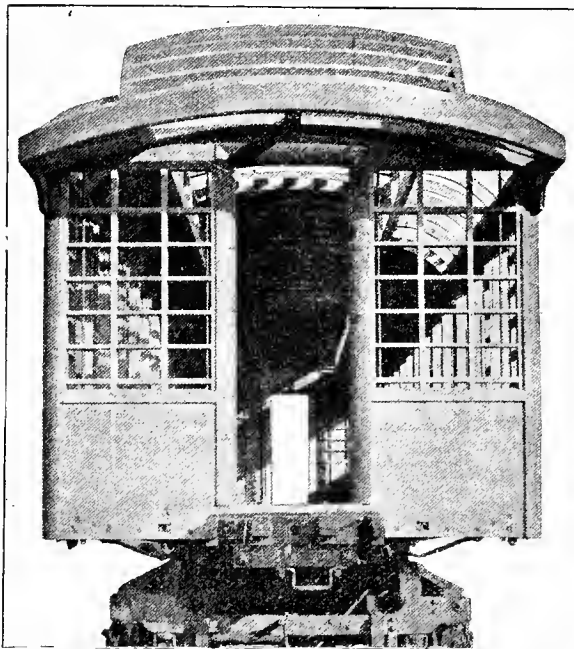

Fig. 534. *End View, showing Hood and End Framing.*

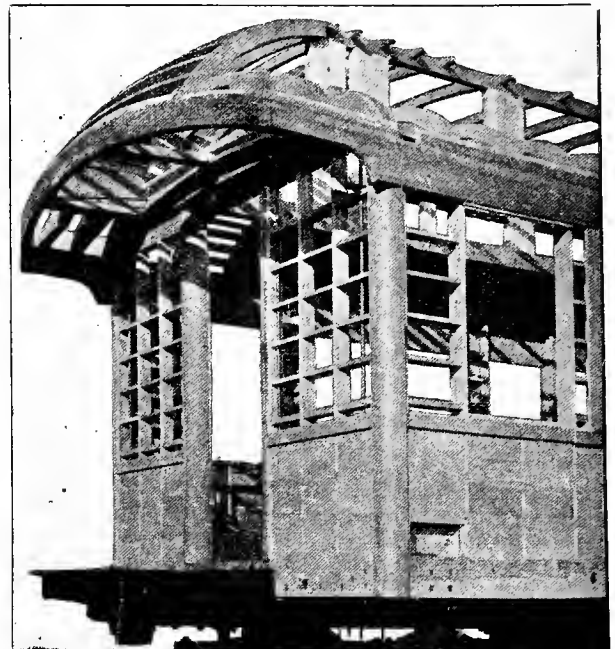

Fig. 535. *Corner View, showing Hood, End and Side Framing.*

PASSENGER CAR FRAMING ADOPTED BY PULLMAN'S PALACE CAR COMPANY.

NAMES OF PARTS ; Figs. 531-538.

- 20. Body Truss-rod.
- 22. Body Queen-post.
- 26. Cross-tie-timber.
- 26t. Cross-tie-timber Truss-rod.
- 26p. Cross-tie-timber Truss-rod Bearing.
- 51. Brace.
- 58. Window-post.
- 59. Sheathing Furring.
- 59b. Furring-blocks.
- 59e. End-sheathing or End Panel-furring.
- 60. Stud.
- 60e. End-studs.
- 61. Corner-post.
- 62. Door-post.
- 63. Truss-plank.
- 65. Belt-rail.
- 65a. Auxiliary Belt-rail.
- 66. Sheathing-rail.
- 81. Belt-rail Cap.
- 90. Window-lintel.
- 93. Eaves-moulding.
- 98. Plate.
- 99. Door-lintel.
- 100. Compound Carline.
- 101. Rafter.
- 102. Roof Boards.
- 108. Platform-hood Bow.
- 111. Deck-sill.
- 115. Deck-post.
- 117. Deck-plate.
- 118. Upper-deck Carline.
- 137. Window.
- 163. Compression-beam.

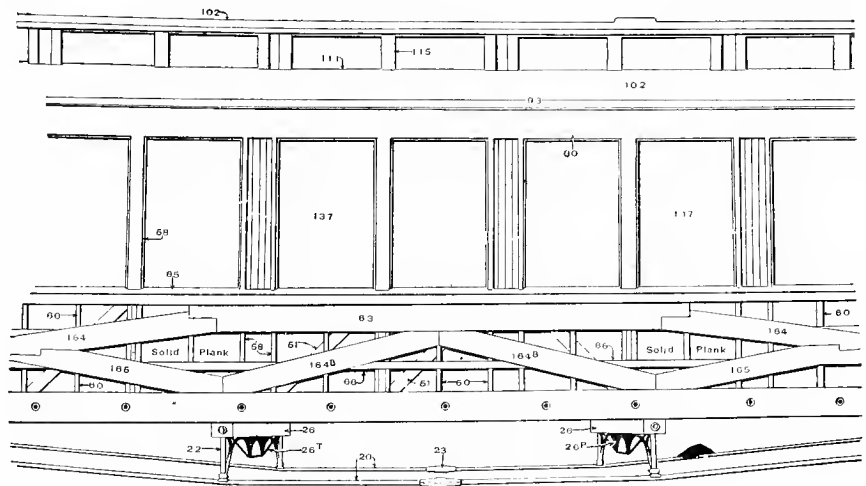

Fig. 536. Part Side Elevation.

- 164. Compression-beam Brace.
- 164b. Auxiliary Compression-beam Brace.
- 165. Counterbrace.
- 260. Deck End-sill.

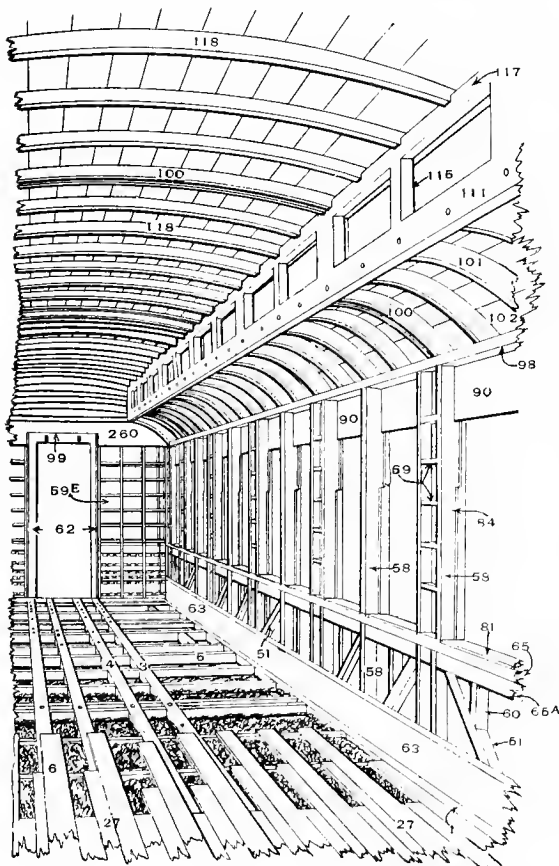

Fig. 537. Interior View.

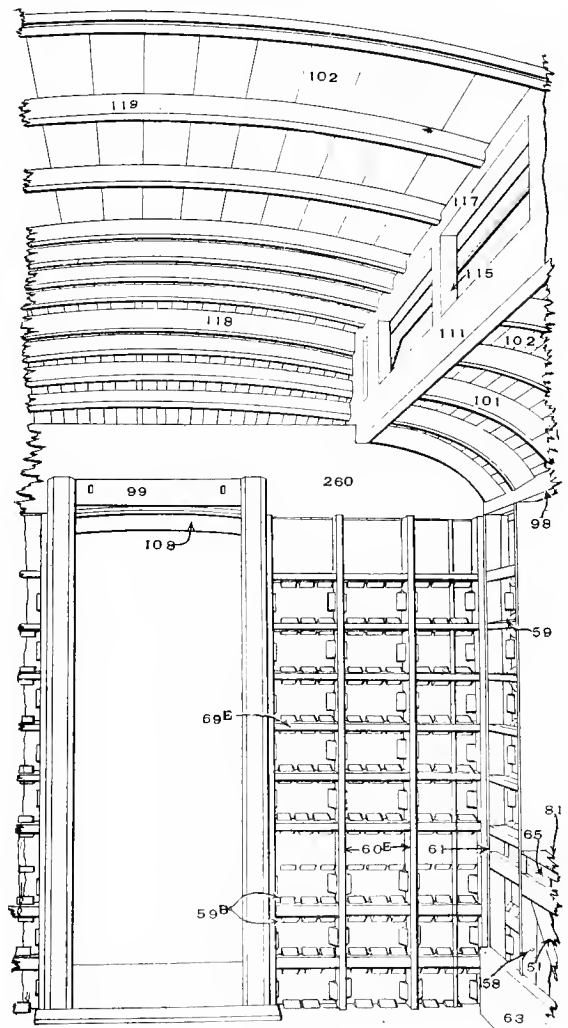

Fig. 538. Interior View.

PASSENGER CAR FRAMING, ADOPTED BY PULLMAN'S PALACE CAR COMPANY.
BALTIMORE & OHIO, WABASH AND OTHER RAILROADS.

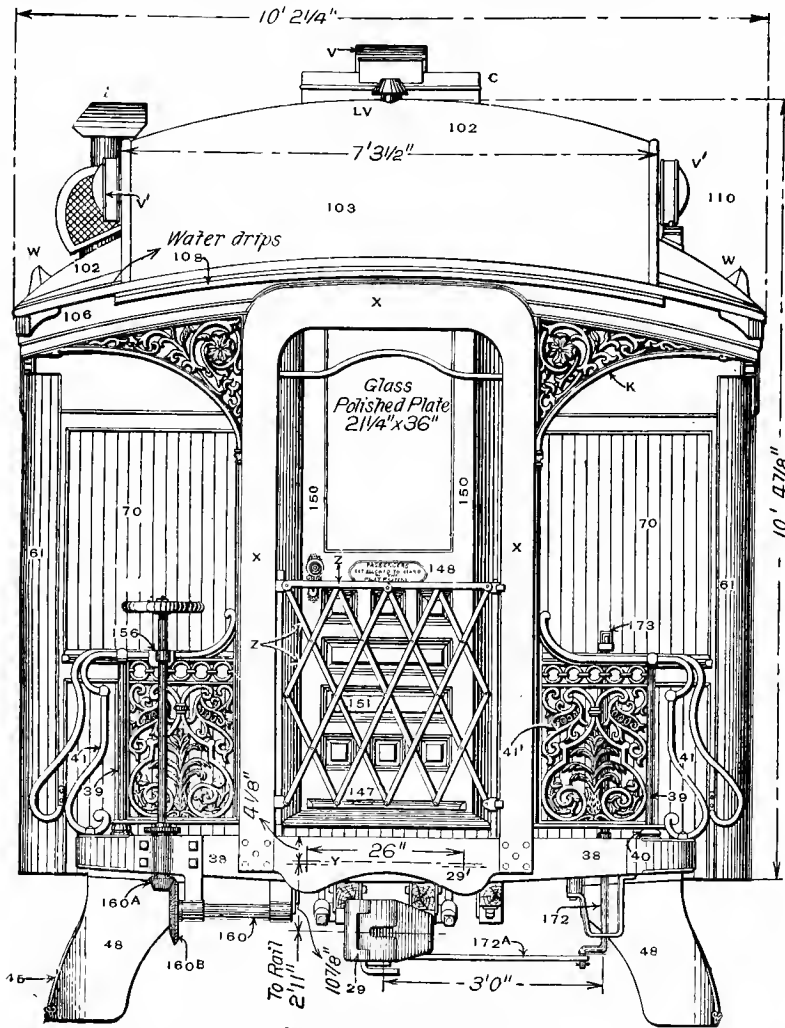

Fig. 539. End Elevation.
FIRST-CLASS PASSENGER COACH.

- 88. Window Moulding.
- 89. Inside Window-panel.
- 90. Window-lintel.
- 91. Letter-board.
- 92. Fascia-board.
- 93. Eaves-moulding.
- 94. Inside Cornice.
- 95. Inside Cornice Fascia-board.
- 97. Inside Lining.
- 98. Plate.
- 99. Door-lintel.
- 100. Compound Carline.
- 101. Rafter.
- 102. Roof Boards.
- 104. Platform-roof Carline.
- 105. Platform-roof End-carline.
- 106. Roof-apron.
- 108. Platform-hood Post.
- 110. Clear-story or Upper Deck.
- 111. Deck-sill.
- 112. Deck Bottom-rail.
- 113. Deck End-sill.
- 114. Deck-sill Facing.
- 114a. Deck-sill Sub-facing.
- 115. Deck-post.
- 116. Deck End-panel or Ventilator.
- 118. Upper-deck Carline.
- 120. Inside Deck-cornice.
- 121. Deck-plate (117).
- 121s. Deck Soffit-board.
- 122. Car Seat.
- 123. Seat-end or Aisle Seat-end.
- 124. Seat-stand.
- 125. Seat-back.
- 137. Window.
- 140. Window-blind.
- 140a. Window-shade.

(Continued)

NAMES OF PARTS, Figs. 539-541.

- | | |
|---|---------------------------------|
| 1. Side-sill. | 48. Step-hanger. |
| 2. End-sill. | 51'. End-brace. |
| 3. Intermediate-sill. | 54. End Sill-and-plate Rod. |
| 3a. Outer Intermediate-sill. | 58. Window-post. |
| 4. Center-sill. | 61. Corner-post. |
| 6. Bridging. | 62. Door-post. |
| 7. Floor-timber Brace. | 63. Truss-plank. |
| 9. Sill Tie-rod. | 65. Belt-rail. |
| 10. Body-bolster. | 65a. Window-sill Cornice-board. |
| 20. Body Truss-rod. | 66. Sheathing-rail. |
| 22. Body Queen post. | 67. Outside Panel or Sheathing. |
| 22b. Body Queen-post Brace. | 70. Sheathing. |
| 23. Turbuekle. | 74. Lower Wainscot-rail. |
| 26. Cross Tie-timber. | 75. Upper Wainscot-rail. |
| 27. Floor. | 76. Wainscot-panel. |
| 28. Deafening-ceiling. | 77. Outside Window-sill. |
| 29. Drawbar or Coupler. | 78. Inside Window-sill. |
| 29'. Vestibule Buffer-plate. | 80. Window-sill Moulding. |
| 35. Platform-sill. | 82. Upper Belt-rail. |
| 37. Platform Short-sill. | 85. Window-sash. |
| 38. Platform End-sill. | 86. Window Blind-sash. |
| 39. Platform-railling Post. | 87. Window Cove-moulding. |
| 40. Base-washer for Platform-railling Post. | |
| 41. Platform-rail. | |
| 44. Body Hand-rail. | |
| 45. Platform-step. | |

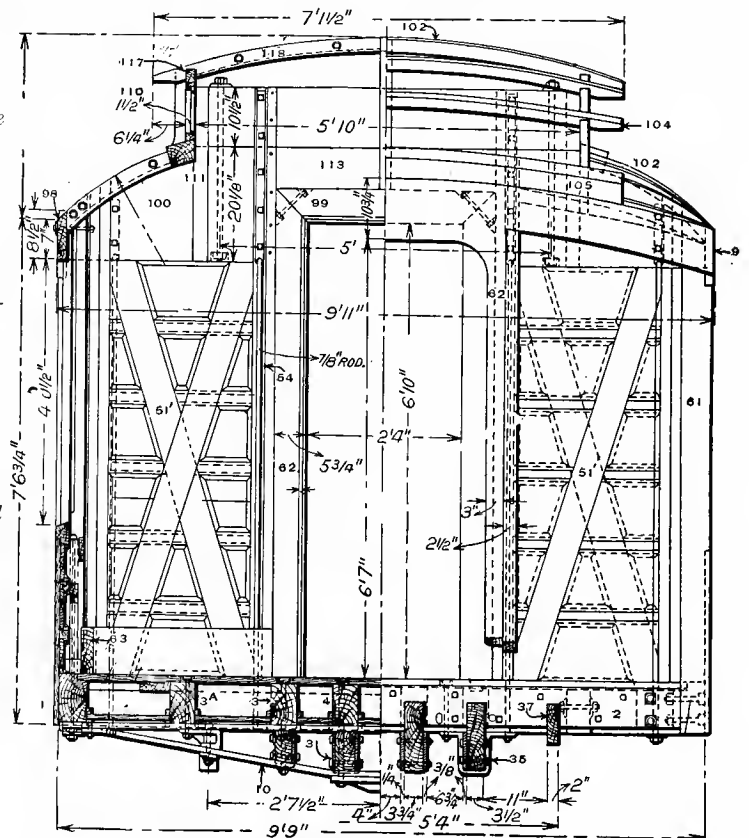

Fig. 539a. End Elevation of Framing.
FIRST CLASS PASSENGER COACH.
(Full Framing is Shown in Figs. 419-427.)

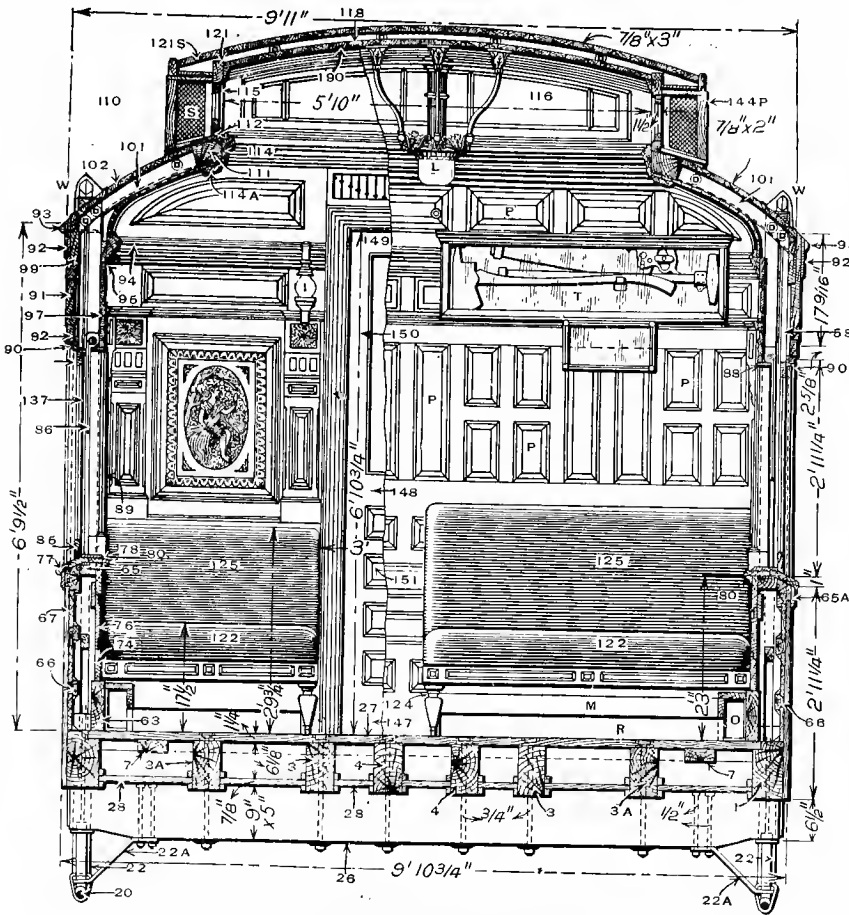

Fig. 540. Transverse Section Showing Interior.
FIRST-CLASS PASSENGER COACH.

- A. Basket-rack.
- B. Bell-cord and Hanger.
- C. Frost Carburetor.
- D. Deck-sash Window-opener.
- E. Base of Pilaster.
- F. Cap of Pilaster.
- G. Rafter Ribs and Cornices.
- H. Heater or Seal-radiator.
- J. Sash-lift.
- K. Platform End-bracket.
- L, L. Center-lamp.
- L. Vestibule-lamp Ventilator.
- M. Seat-frame.
- O. Box for Heating-pipes.
- P, P. Panels.
- R. Seat Radiator, same as H.
- S. Deck Window-screens.
- T. Emergency Tool-box.
- V. Lamp Jack or Ventilator.
- V. Saloon Ventilator.
- W. Window sash Balance.
- X. Vestibule Face plate.
- Y. Vestibule Buffer plate.
- Z. Vestibule Gate.

NAMES OF PARTS, Figs. 539-541.

(Continued.)

- 144. Deck-sash or Deck-window.
- 144p. Deck-screen Post.
- 145 or A. Continuous Basket-rack.
- 147. Bottom Door-rail.
- 148. Middle Door-rail.
- 149. Top Door-rail.
- 150. Door stile.
- 151. Door panel.
- 152. Brake-shaft.
- 156. Upper Brake-shaft Bearing.
- 157. Brake Hand-wheel.
- 160. Brake-chain Worm.
- 160a. Brake-chain Sheave.
- 160b. Brake-shaft Bevel Gear wheel.
- 172. Uncoupling-shaft.
- 172a. Uncoupling-rod.
- 173. Uncoupling-lever.
- 190. Ceiling.

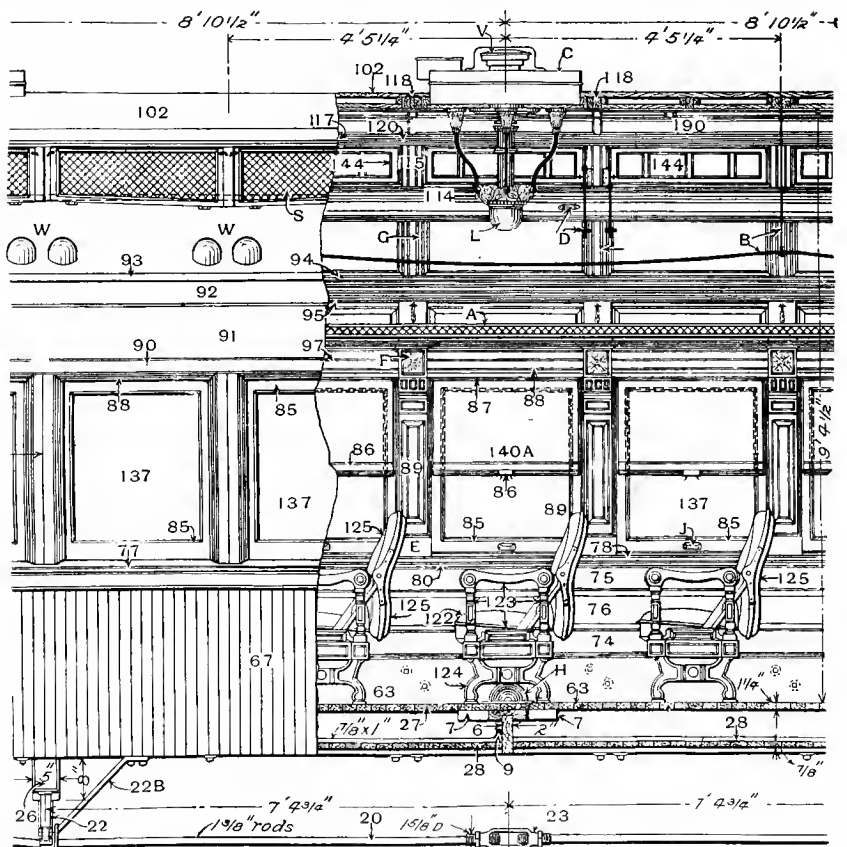

Fig. 541. Sectional Side Elevation, showing Exterior and Interior
FIRST-CLASS PASSENGER COACH.
(Full elevation and plan are shown in Figs. 419-427.)

NAMES OF PARTS. Figs. 542-567.

- | | |
|---|---|
| 1. Side-sill. | 86s. Window-blind. |
| 1a. Side-sill Fitch-plank. | 90. Window-lintel. |
| 1b. Sill Fitch-plate. | 91. Letter-board. |
| 3a. Outer Intermediate-sill. | 92. Eaves Sub-fascia-board. |
| 3. Intermediate-sill. | 93. Eaves Fascia-board. |
| 4. Center-sill. | 94. Inside Cornice. |
| 9. Sill Tie-rod. | 94b. Plate Facing, or Inside
Cornice Fascia-board. |
| 27. Car Floor. | 95. Inside Cornice Fascia-
board, same as 94b. |
| 27b. Sub-car-floor. | 97. Inside Lining. |
| 28. Deafening Ceiling. | 98. Plate. |
| 54. Sill-and-plate Rod. | 98a. Auxiliary Plate. |
| 58. Window-post. | 98b. Upper Window Panel-
rail. |
| 59. Window-panel or
Sheathing Furring. | 99. Door Lintel. |
| 63. Truss-plank. | 99b. Door Lintel Top-rail. |
| 64. Truss-plank Cap or
Moulding. | 100. Compound Carline. |
| 65. Belt-rail. | 101. Rafter. |
| 66. Sheathing-rail. | 102. Roof-boards. |
| 67. Sheathing. | 111. Deck-sill. |
| 67b. Inside Lining. | 111a. Deck-sill Side-mould-
ing. |
| 67f. Inside Lining over
Window. | 111b. Deck-sill Top-mould-
ing. |
| 74. Lower Wainscot-rail. | 111c. Same as 112. |
| 75. Upper Wainscot-rail. | 112. Deck Bottom-rail. |
| 76. Middle Wainscot-rail or
Panel. | 113. Deck End-sill. |
| 77. Outside Window-sill. | |
| 78. Inside Window-sill. | |
| 81. Belt-rail Cap. | |
| 82. Upper Belt-rail. | |
| 83. Sash Parting-strip. | |
| 85. Outside Window-sash. | |
| 85a. Upper Outside Window-
sash. | |
| 86. Inner Window-sash. | |
| 86a. Upper Inner Window-
sash. | |

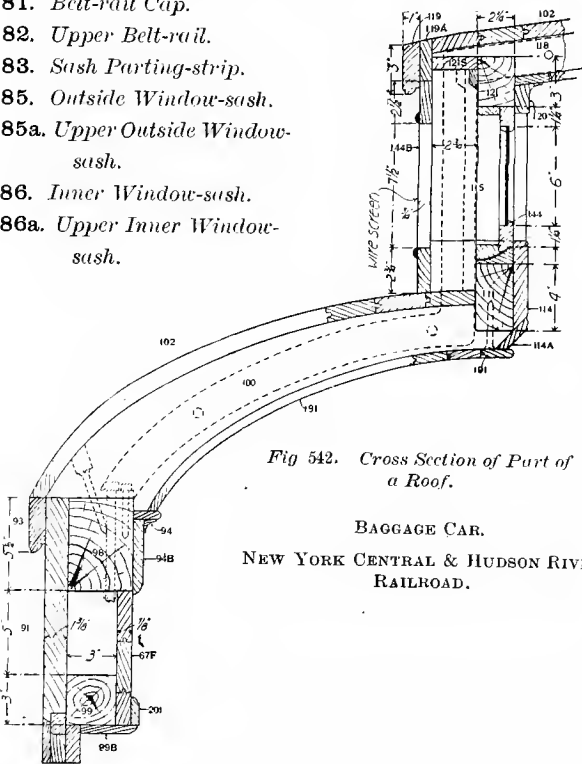

Fig 542. Cross Section of Part of a Roof.

BAGGAGE CAR.
NEW YORK CENTRAL & HUDSON RIVER
RAILROAD.

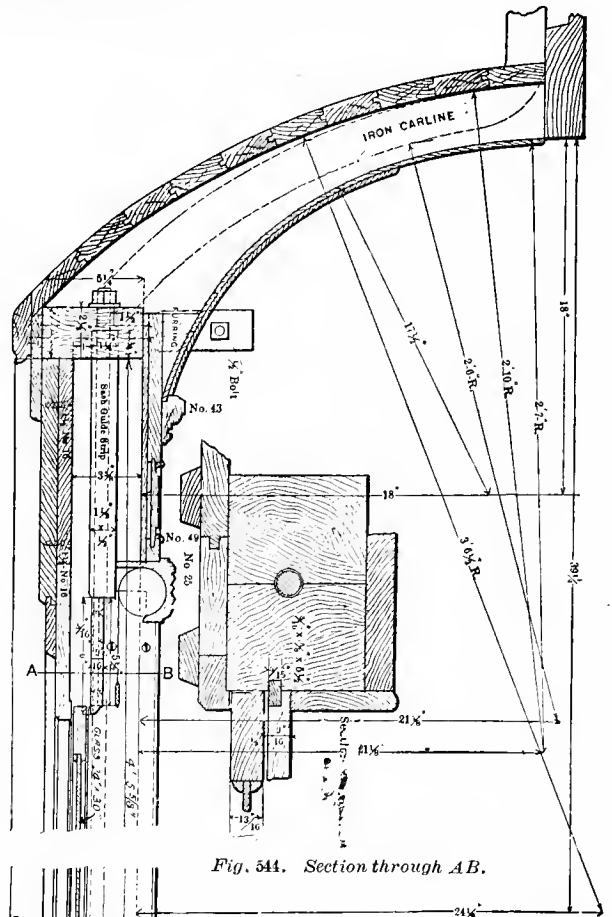

Fig. 544. Section through AB.

NAMES OF PARTS (Continued).
Figs. 542-567.

- | |
|--|
| 114. Deck-sill Facing. |
| 114a. Deck-sill Bottom-
moulding. |
| 115. Deck-post. |
| 117. Deck-plate. (Marked
121 in Figs. 542, 550
and 554). |
| 118. Upper-deck Carline. |
| 119. Deck Eaves-fascia-
board. |
| 119a. Deck Eaves-sub-fascia-
board. |
| 120. Deck Inside Cornice. |
| 121. Deck-plate in Figs. 542,
550 and 554. |
| 121. Deck-cornice Filling-
block in Figs. 551,
556, 560. |
| 121s. Deck Soffit-board. |
| 144. Deck-sash or Window. |
| 144a. Outer Deck-sash for
Screen. |
| 144b. Deck-screen. |
| 146. Door-mullion. |
| 147. Bottom Door-rail. |

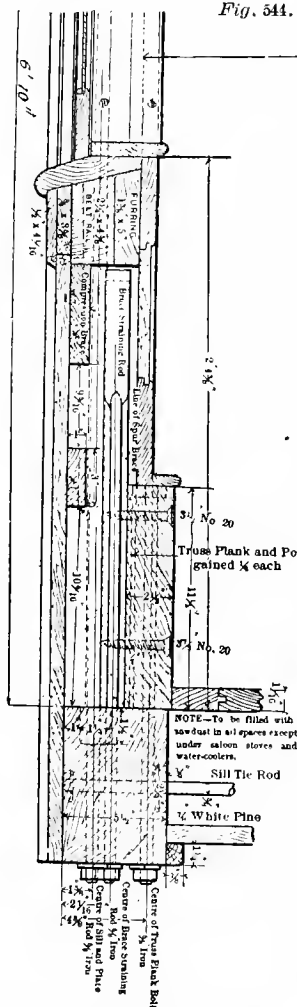
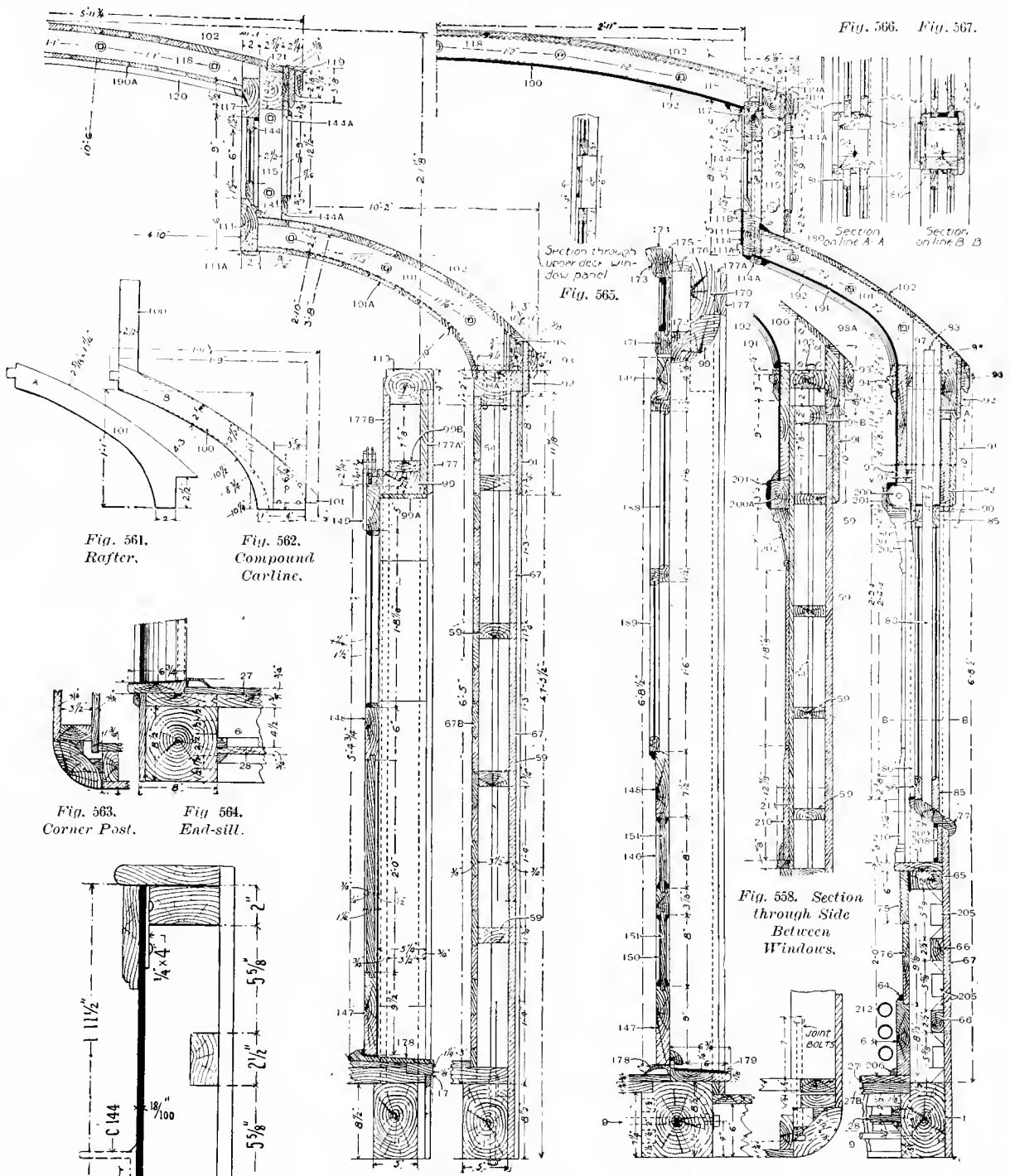

Fig. 543. Transverse Section of Side and Lower Deck.

COACH. BALTIMORE & OHIO RAILROAD.



Cross Sections of Baggage Car. Cross Sections of Passenger Car.

SIDE, END AND ROOF FRAMING OF BAGGAGE AND PASSENGER CAR.
CHICAGO, BURLINGTON & QUINCY RAILROAD.

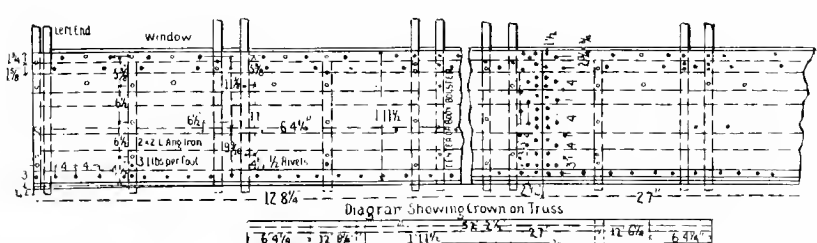
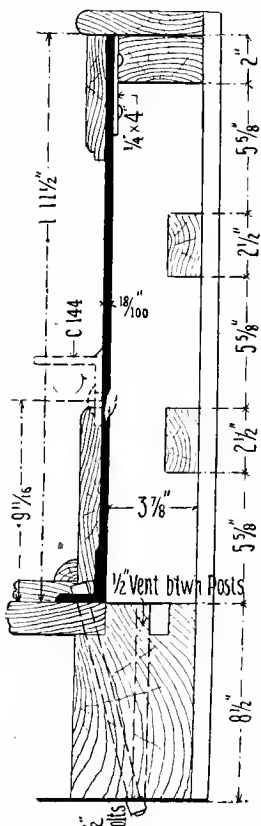

Fig. 568. Cross Section

Fig. 569. Side Elevation.

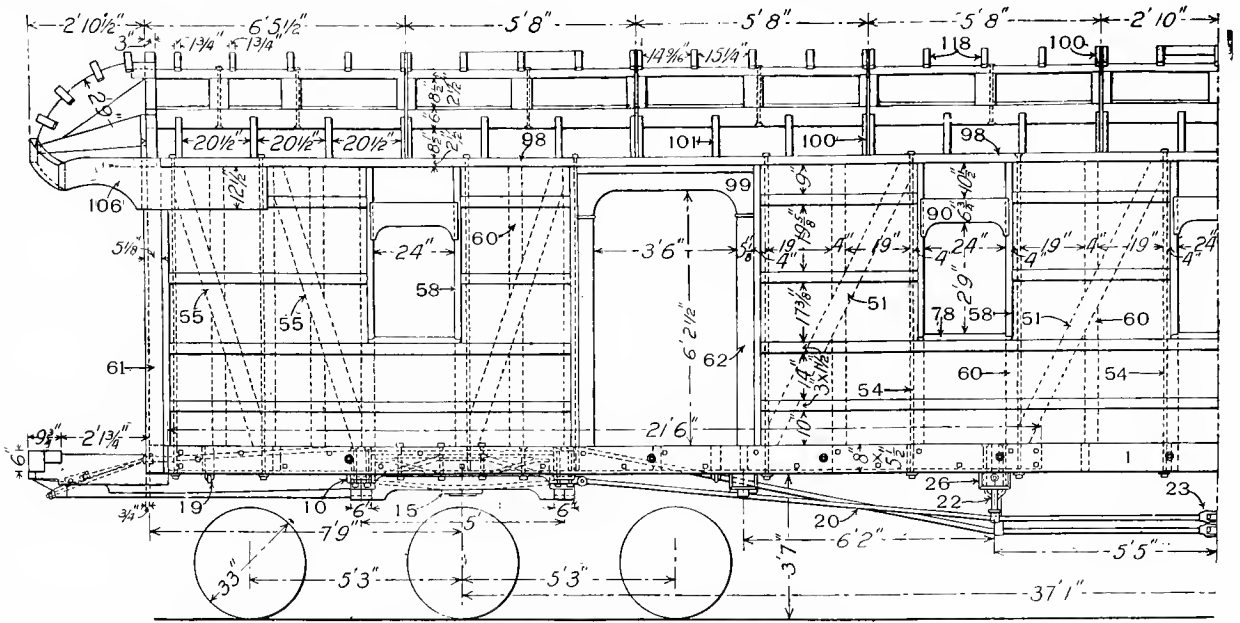

Fig. 570. Side Elevation of Framing.

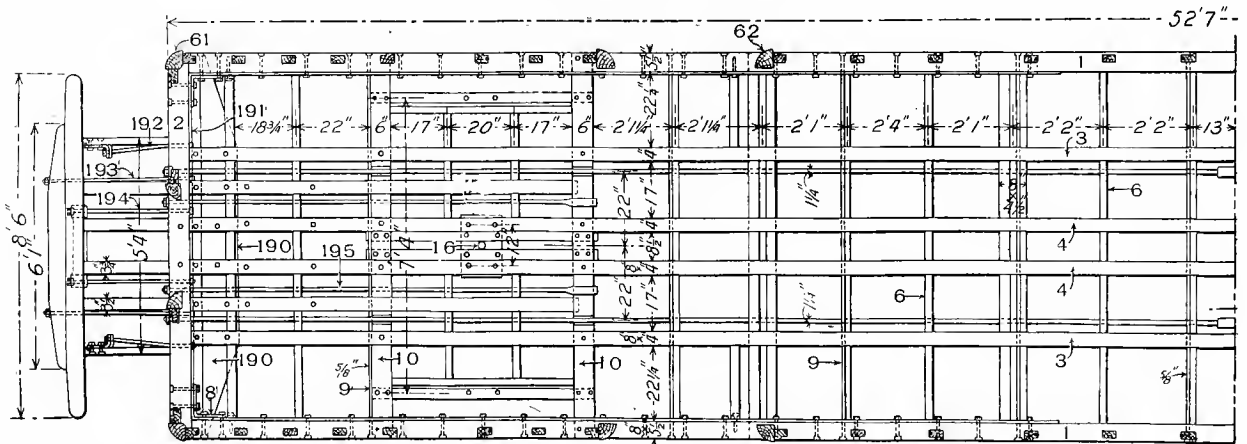

Fig. 571. Plan of Underframing.

BAGGAGE AND EXPRESS CAR. BALTIMORE & OHIO RAILROAD.

NAMES OF PARTS. Figs. 542-567 (Concluded).

- | | |
|---------------------------------------|--|
| 180. Deck-screen Sash-sill. | 206. Base-board Corner Moulding. |
| 188. Upper End-door Sash. | 208. Filling-board (Fig.560). |
| 189. Lower End-door Sash. | 209. Filling-board. |
| 190. Deck Ceiling Veneered. | 210. Base of Pilaster. |
| 190a. Ceiling of Baggage Car. | 211. Inside Sub-lining. |
| 191. Veneering of Lower Deck Ceiling. | 220. Ceiling Strips or Furring (Fig. 554). |
| 191. Lower Deck Veneered Ceiling. | 220b. Ceiling-furring. |
| 191a. Lower Deck Boarded Ceiling. | 221. Ceiling Furring-brace. |
| 200. Hartshorn Roller for Shade. | 222. Berth Front, Upper Part. |
| 200a. Rail between Windows. | 223. Berth-front Panel. |
| 201. Moulding for Shade-roller Box. | 224. Berth Front, Lower Part. |
| 202. Cap for Pilaster. | 225. Top-rail of Pipe-box. |
| 203. Shade. | 226. Bottom-rail of Pipe-box. |
| 205. Furring Brace-blocks. | G. Overhang-truss. |
| | F. Overhang-Truss Tie-rod. |

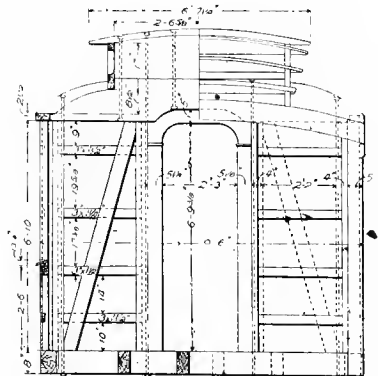

Fig. 571a. Half Cross Section and Half End Elevation, showing Framing.

BAGGAGE AND EXPRESS CAR. BALTIMORE & OHIO RAILROAD.

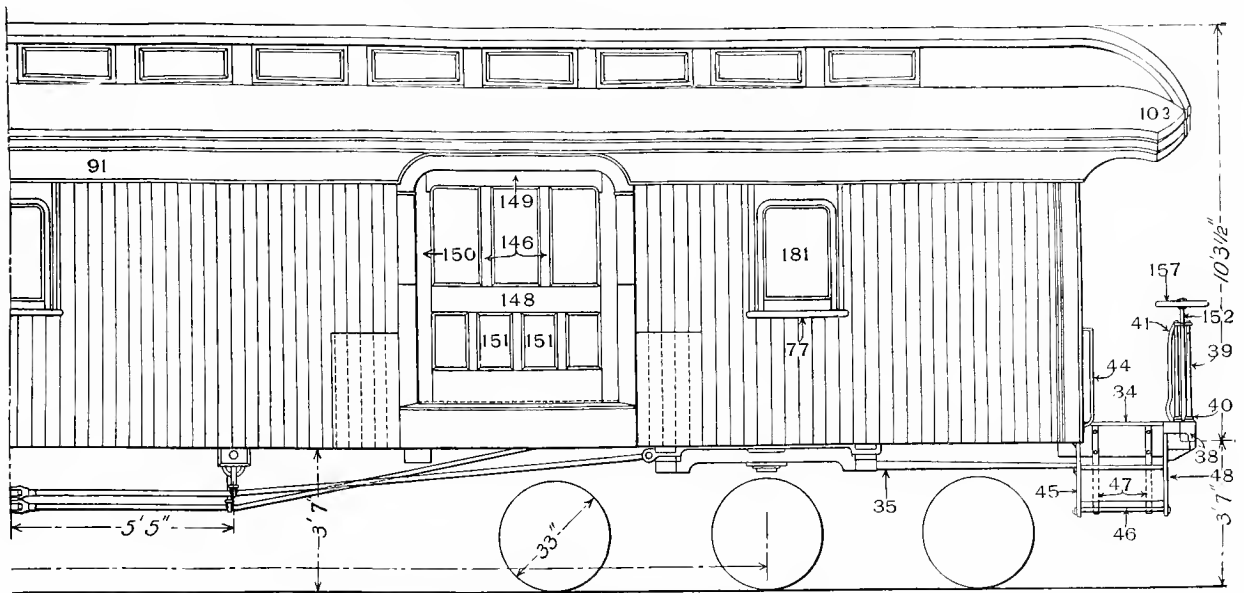

Fig. 572. Half Side Elevation of Exterior.

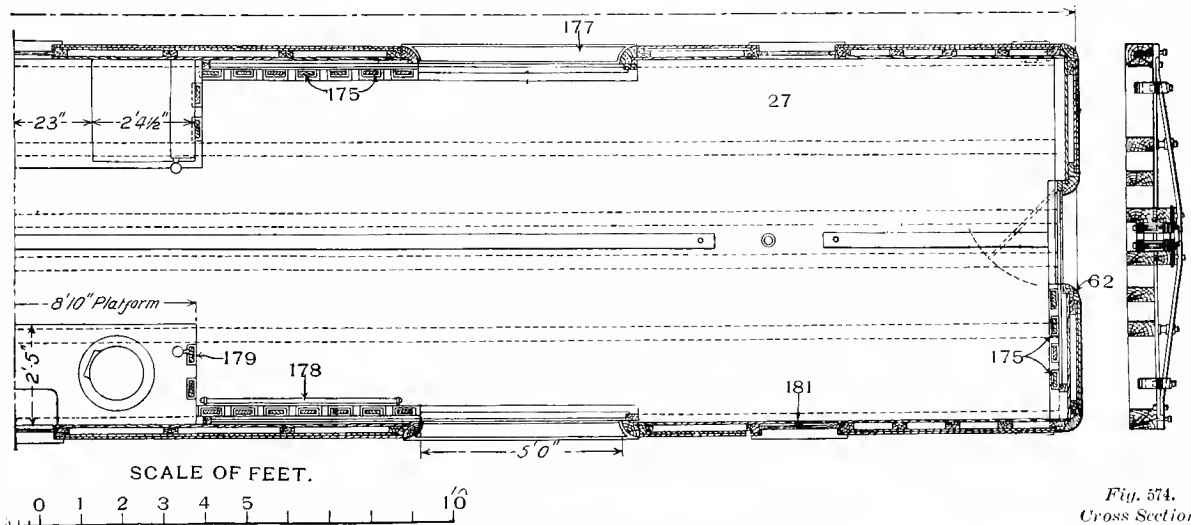

Fig. 573. Half Plan and Horizontal Section of Sides.
BAGGAGE AND EXPRESS CAR. BALTIMORE & OHIO RAILROAD.

Fig. 574.
Cross Section
of Underframe.

NAMES OF PARTS OF BAGGAGE CARS. Figs. 570-583.

- | | | |
|------------------------------|--|---------------------------|
| 1. Side-sills. | 20. Body Truss-rod. | 45. Platform Steps. |
| 1a. Side-sill Fitch-plate. | 22. Body Queen-post. | 46. Tread-board. |
| 1b. Side-sill Fitch-plank. | 23. Turnbuckle. | 47. Step-iron. |
| 2. End-sill. | 26. Cross-tie-timber. | 48. Step-hanger. |
| 2a. End-sill Fitch-plate. | 27. Floor. | 51. Brace. |
| 2b. End-sill Fitch-plank. | 31a. Platform Cross-timber. | 51a. Counter Brace-rod. |
| 3. Intermediate-sill. | 31b. Platform Tie-rod. | 51b. Counter Brace-rod. |
| 3a. Outer Intermediate-sill. | 34. Platform. | 52a. Composite End-posts. |
| 4. Center-sill. | 35. Platform Timbers. | 54. Sill-and-plate Rod. |
| 6. Bridging. | 37. Platform Short-sill. | 55. Counterbrace. |
| 8. Sill Knee-iron. | 38. Platform End-sill. | 58. Window-posts. |
| 9. Sill Tie-rod. | 39. Platform-railing Post. | 60. Stud. |
| 10. Body-bolster. | 40. Base-washer for Platform-railing-post. | 61. Corner-post. |
| 15. Body Center-plate. | 41. Platform Rail. | 62. Door-post. |
| 16. King-bolt. | 42. Body Haul-rail. | 77. Outside Window-sill. |
| 19. Body Check-chain Eye. | | 90. Window-lintel. |

(Continued.)

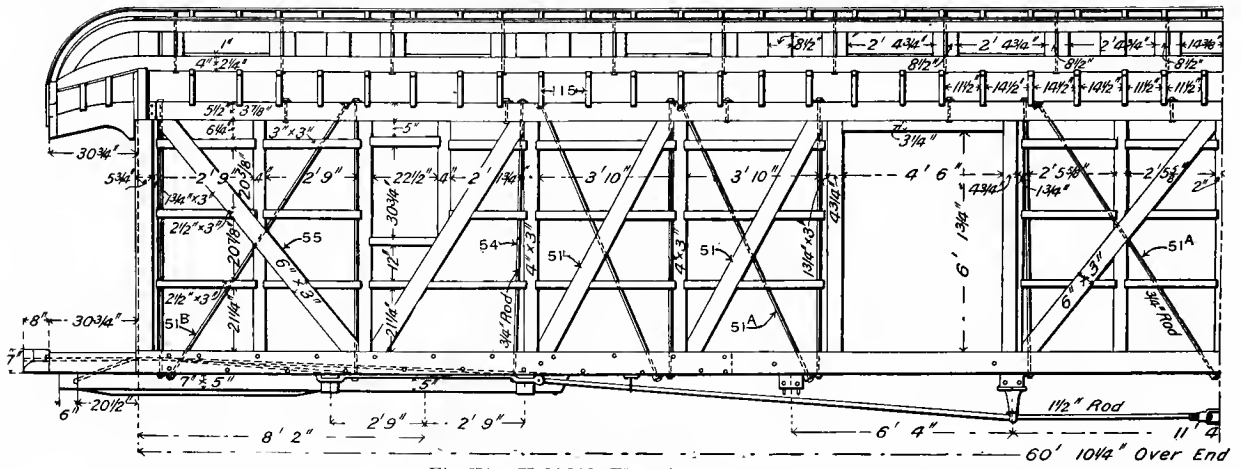

Fig. 574. Half Side Elevation of Framing.

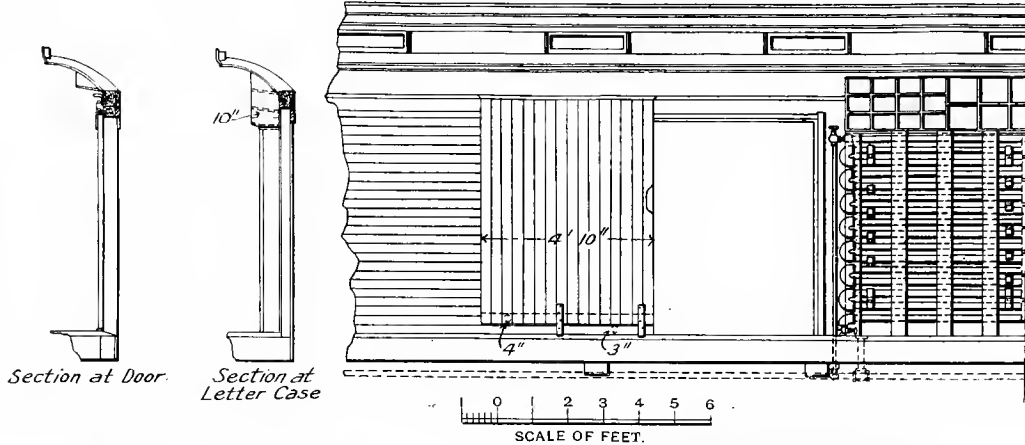

Fig. 575.

Fig. 576.

Fig. 577. Part Side Elevation of Interior.

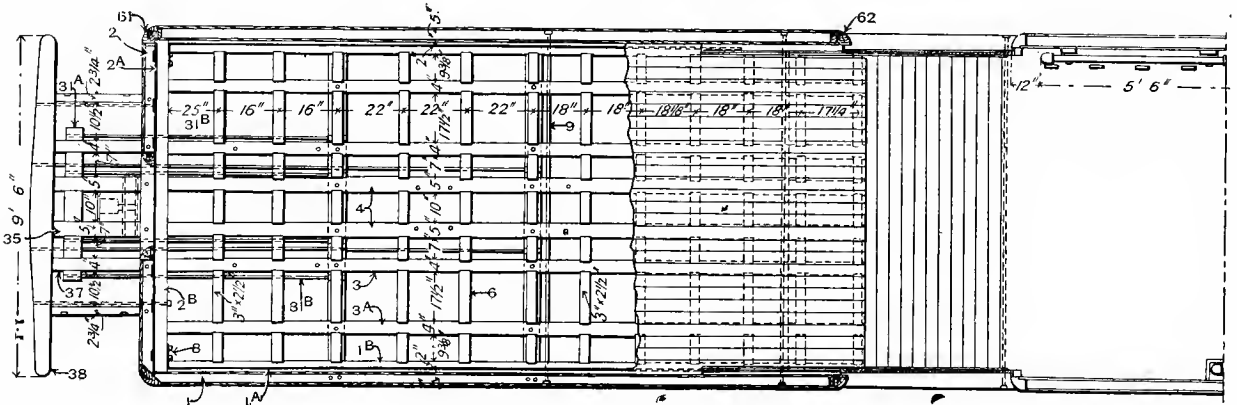

Fig. 578. Part Plan of Underframing.

BAGGAGE CAR. NEW YORK CENTRAL & HUDSON RIVER RAILROAD.
(Details are shown in Figs. 1176-1363.)

NAMES OF PARTS OF BAGGAGE CARS. Figs. 570-583. (Concluded.)

- | | | |
|----------------------------------|--------------------------|-------------------------------------|
| 91. Letter-board. | 115. Deck-post. | 175. Door Guards. |
| 98. Plate. | 117. Deck-plate. | 177. Door-threshold. |
| 99. Door-lintel. | 118. Upper-deck Carline. | 179. Guard for Heater. |
| 100. Compound-carline. | 146. Door-mullion. | 181. Window. |
| 101. Rafter. | 148. Door Middle-rail. | 190. End-sill Stiffening-plate. |
| 103. Platform Roof. | 149. Door Upper-rail. | 191. End-sill Stiffening-angle. |
| 106. Roof-apron. | 150. Door-stile. | 192. Platform Short-sill Tie-rod. |
| 111. Deck-sill. | 151. Door-panels. | 193. Platform End-sill Tie-rod. |
| 113. Deck End-sill. | 152. Brake-shaft. | 194. Platform Truss-rod. |
| 113a. End-sill Stiffening-plate. | 157. Hand Brake-wheel. | 195. End-plate-and-bolster Tie-rod. |

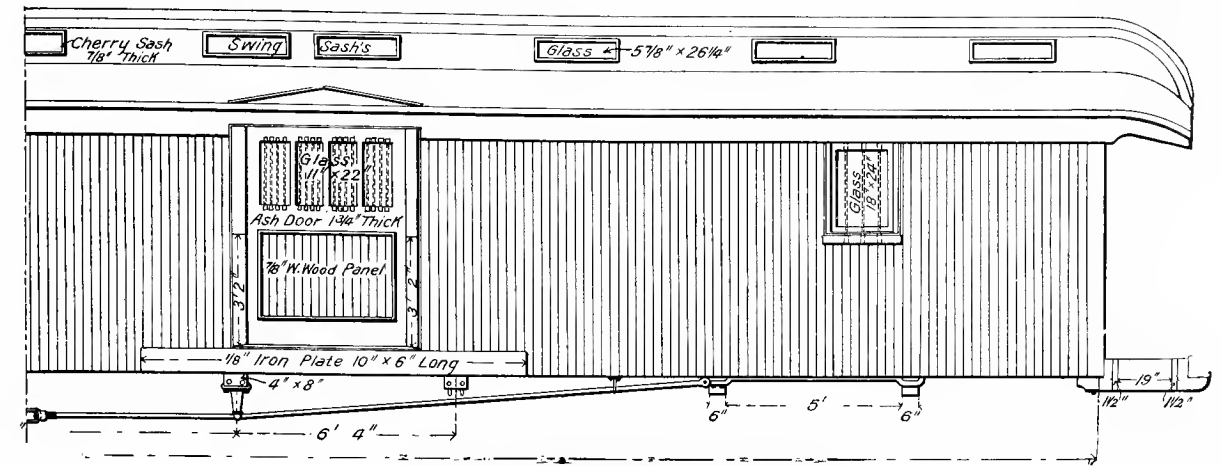

Fig. 579. Half Side Elevation of Exterior.

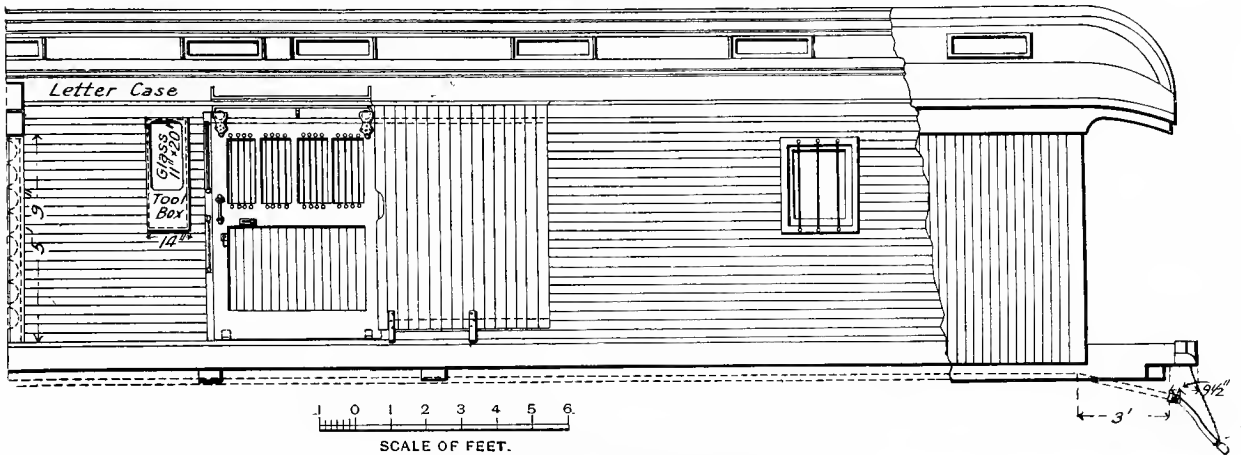

Fig. 580. Half Side Elevation of Interior.

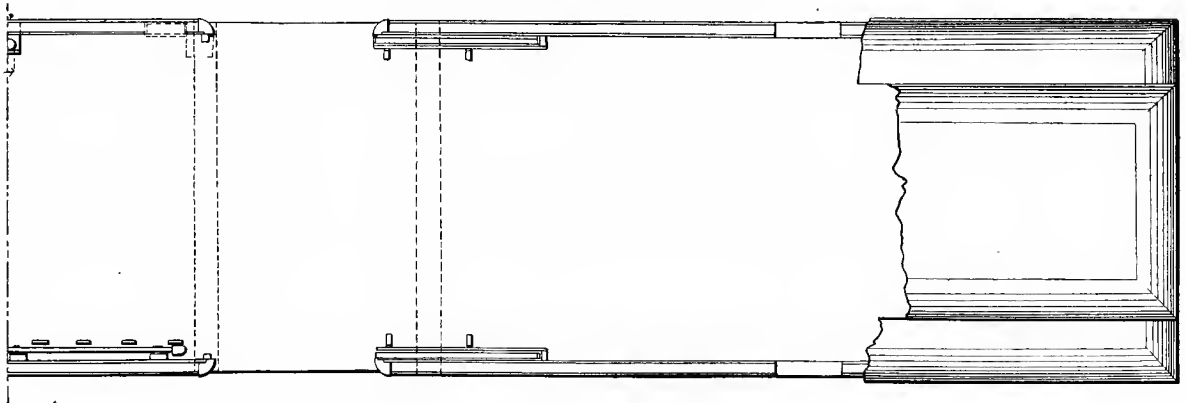

Fig. 581. Half Plan of Floor and Roof.

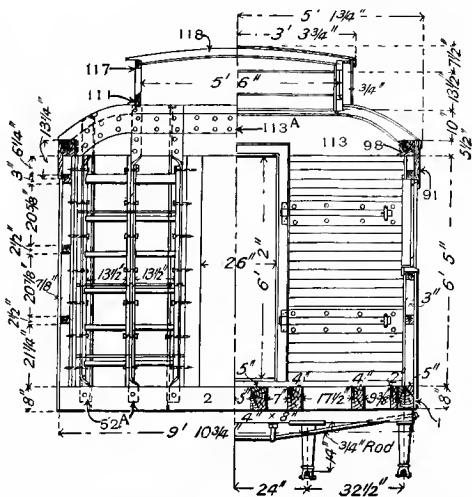

Fig. 582. Half End Elevation of Framing and Cross Section.

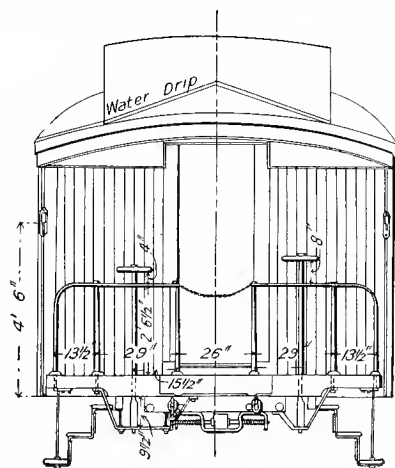

Fig. 583. End Elevation.

BAGGAGE CAR. NEW YORK CENTRAL & HUDSON RIVER RAILROAD.
(Details are shown in Figs. 1176-1363.)

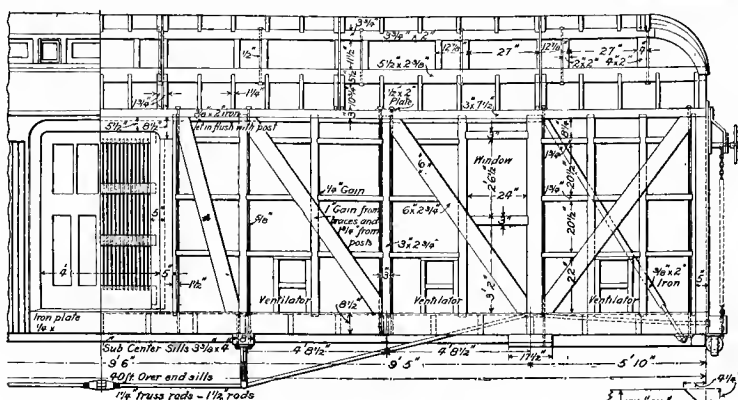

Fig. 584. Half Side Elevation of Framing.

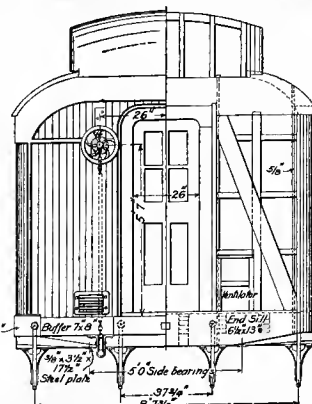

Fig. 585. End Elevation.

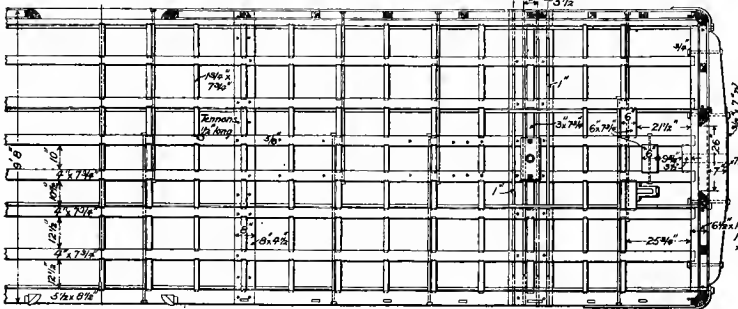

Fig. 586. Half Plan of Underframe.

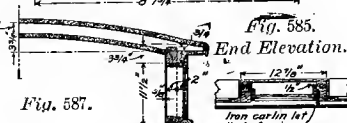

Fig. 587.



Fig. 588.

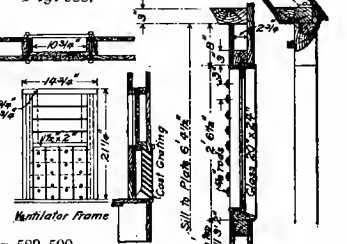

Fig. 589-590.

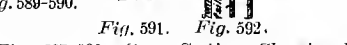

Fig. 591.

EXPRESS CAR WITHOUT PLATFORMS. LOUISVILLE & NASHVILLE RAILROAD.

Figs. 587-592. Cross Sections Showing Framing.

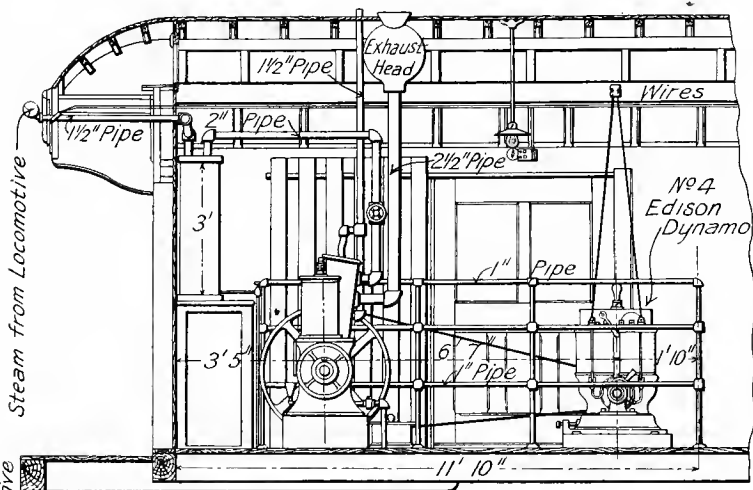
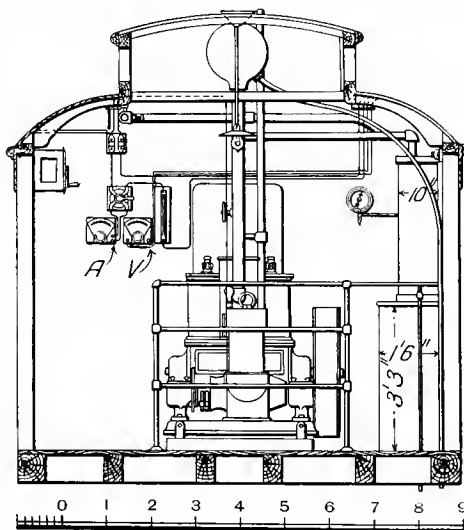

Fig. 593. Part Side Elevation.



SCALE OF FEET.

Fig. 595. Sectional End Elevation.

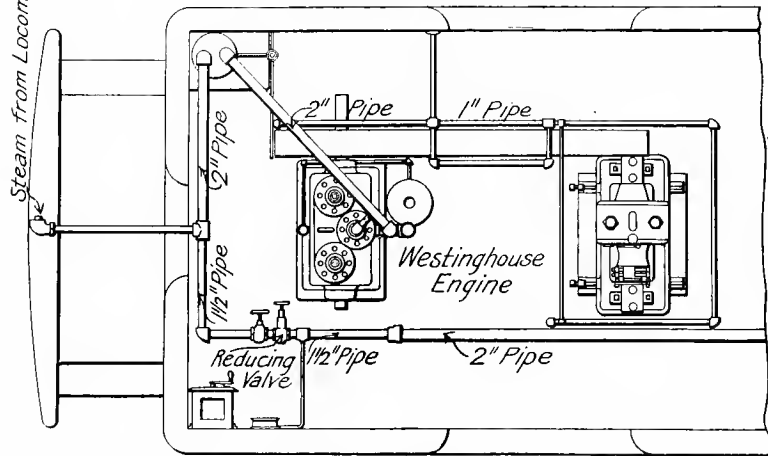

Fig. 594. Part Plan.

ELECTRIC LIGHT PLANT IN END OF BAGGAGE CAR. CHICAGO, MILWAUKEE & ST. PAUL RAILWAY

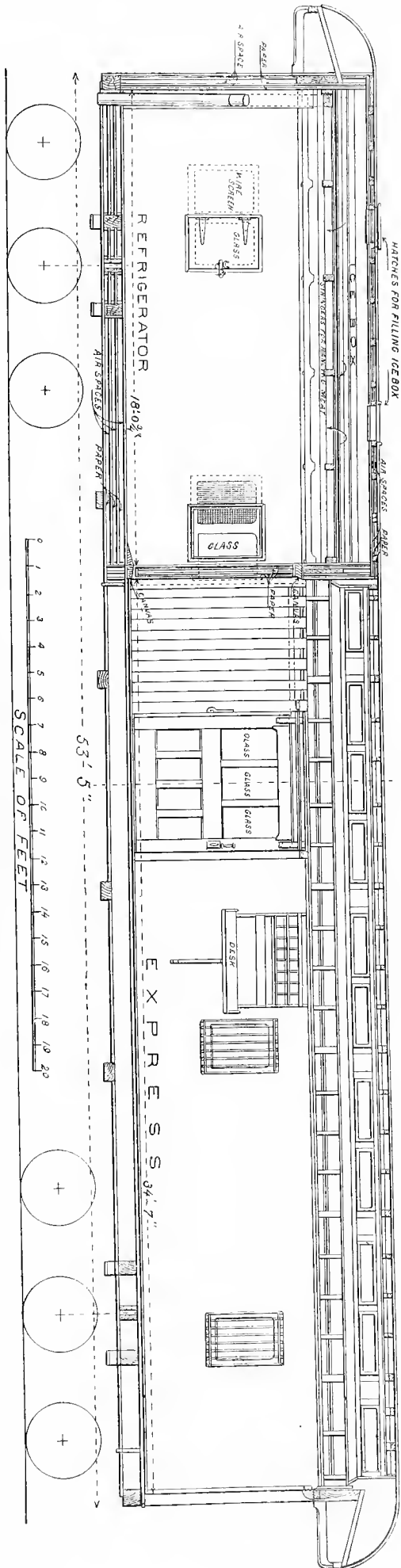

Fig. 596. *Transverse Section.*
REFRIGERATOR-EXPRESS CAR. BALTIMORE & OHIO RAILROAD.
Length, 53 ft. 5 ins. Capacity, 40,000 lbs. Weight, 63,000 lbs.

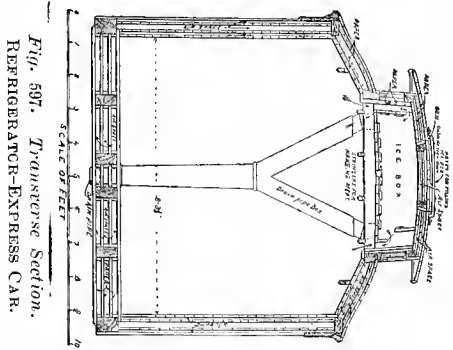

Fig. 597. *Transverse Section.*
REFRIGERATOR-EXPRESS CAR.

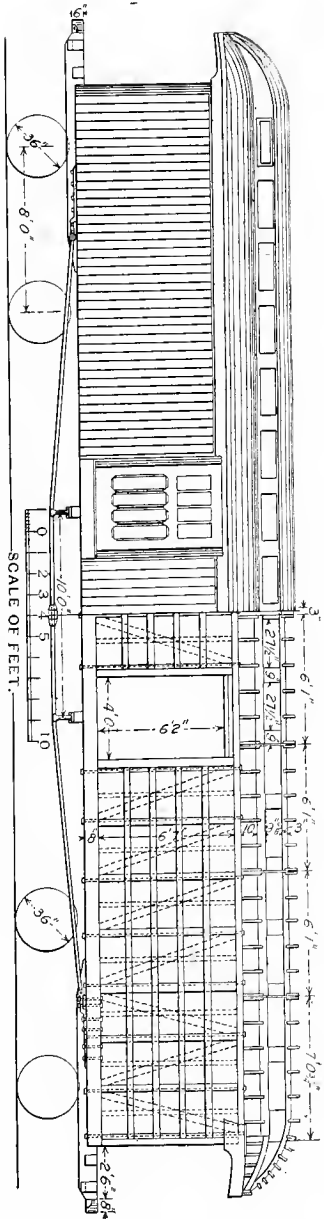

Fig. 598. *Half Side Elevation, showing Side and Side Framing.*
BAGGAGE CAR, BUILT BY PULLMAN'S PALACE CAR COMPANY.

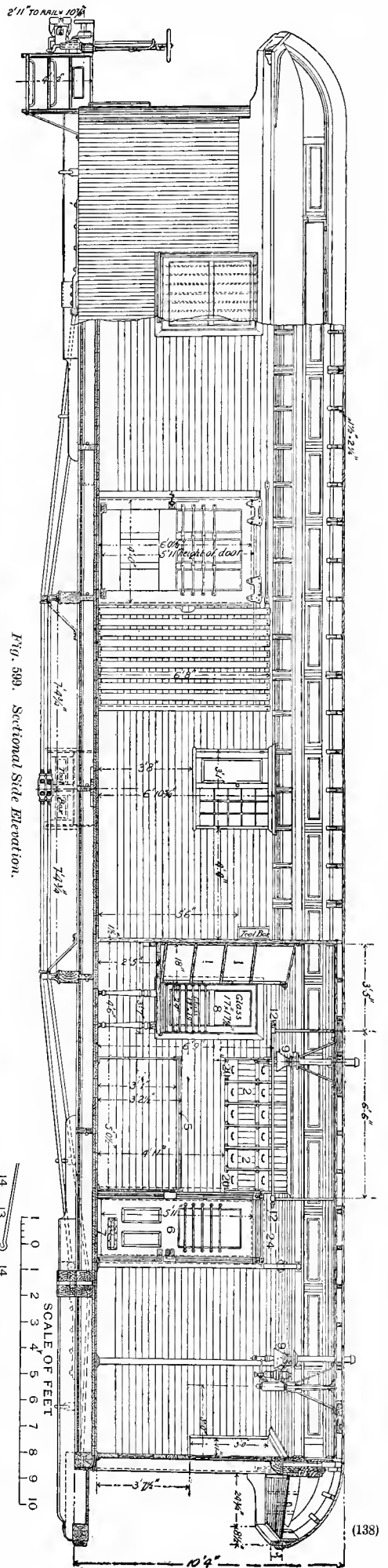

Fig. 599. Sectional Side Elevation.

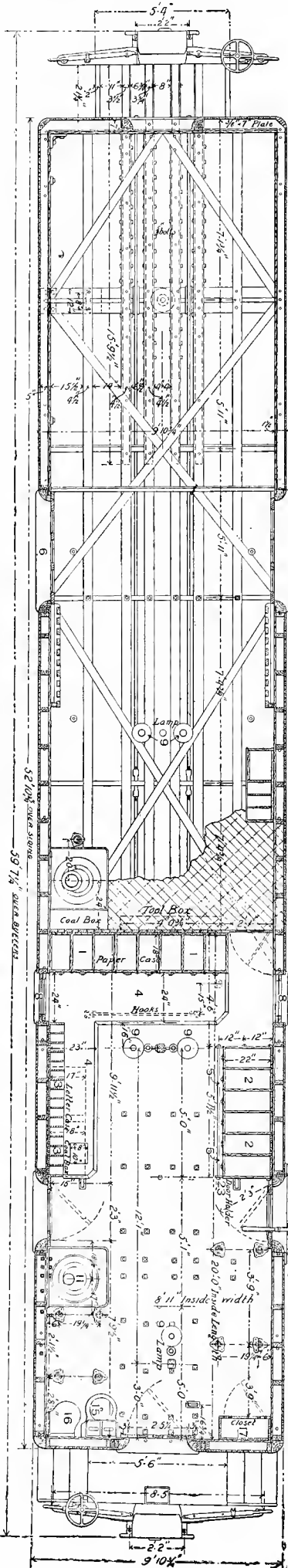

Fig. 600. Sectional Plan, Showing Underframing and Floor of 20-T. Mail Compartment. COMBINATION BAGGAGE AND MAIL CAR. NORFOLK & WESTERN RAILROAD.

Names of Parts of Postal Cars. Figs. 599-604.

1. Paper-box over Distributing-table.
2. Paper-case over Pouch-track.
3. Letter-case.
4. Distributing-table.
5. Pouch-track.
6. Postal-door.
7. Letter-drop.
8. Windows.
9. Postal-lamp.
11. Heater.
12. Safety-val.
13. Mail-collector.
14. Mail-collector Socket.
15. Water cooler and Wash-basin.
16. Water-closet Seat.
17. Clothes-closet.
18. Passage-way Door.
19. Tool-case.
20. Label-holders.
21. Pouch or Bag-looks.
24. Side Door Handle-rod.

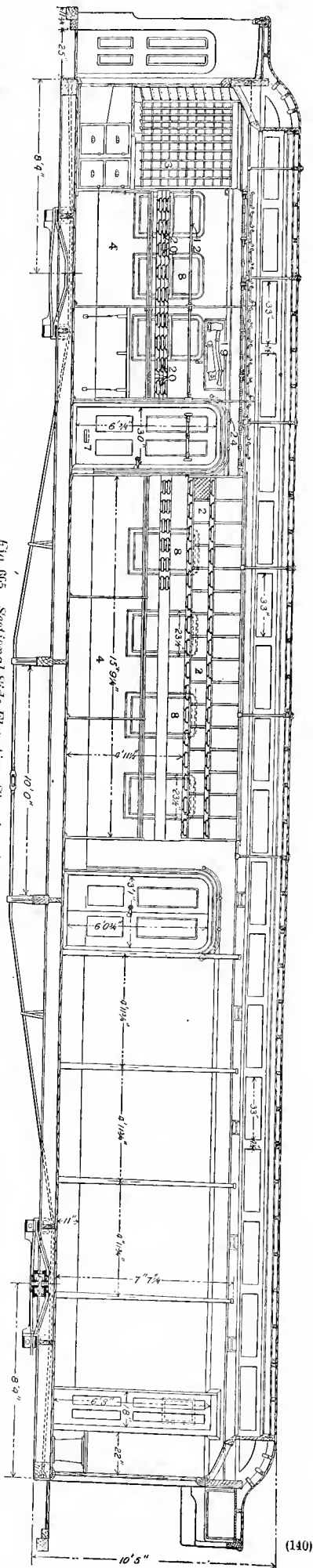

Fig. 605. Sectional Side Elevation, Showing Arrangement of Interior.

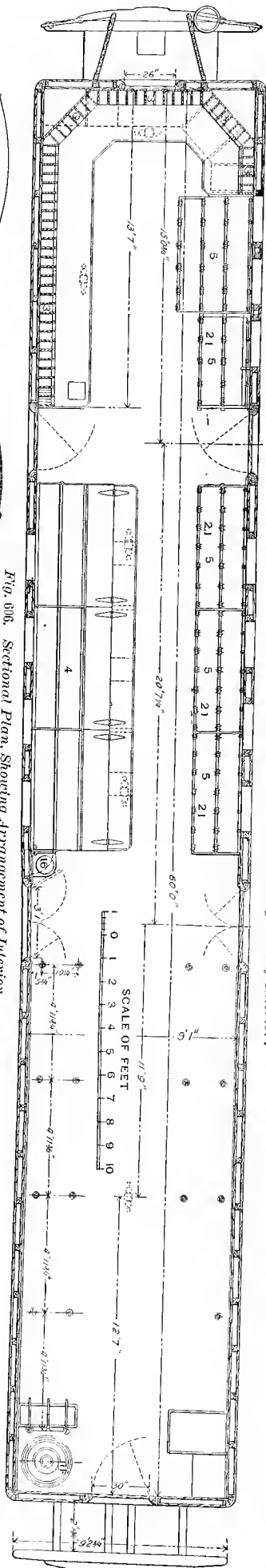

Fig. 606. Sectional Plan, Showing Arrangement of Interior.

POSTAL CAR. PENNSYLVANIA RAILROAD.
Arrangement approved by United States Railway Mail Service, Second Division.

NAMES OF PARTS OF POSTAL CAR. Figs. 605-612.

- | | | |
|---|------------------|----------------------------------|
| 1. Paper boxes over Distributing-table. | 7. Letter-drop. | 15. Water-cooler and Wash-basin. |
| 2. Paper-boxes over Pouch-rack. | 8. Windows. | 16. Water-closet. |
| 3. Letter-case. | 9. Postal lamp. | 17. Clothes-closet. |
| 4. Distributing Table. | 10. Safety-trap. | 19. Tool-crate. |
| 5. Pouch-rack. | 11. Heater. | 20. Label Holder. |
| 6. Postal-door (divided). | 12. Safety-rod. | 21. Pouch or Bag Hooks. |
| | | 24. Side-door Handle-rod. |

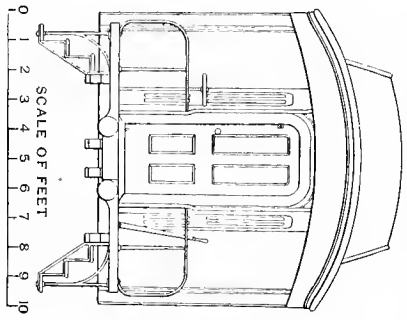

Fig. 607. End Elevation.

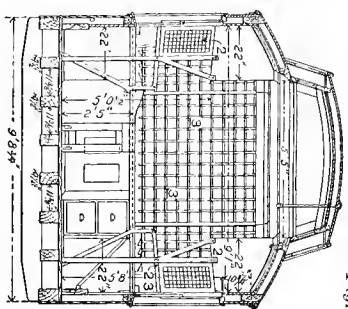

Fig. 608. Transverse Section.

Numbers Refer to List of Names with Figs. 605-608.

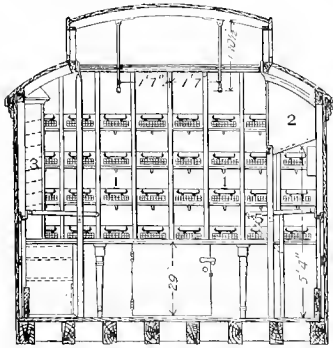

Fig. 609. *Transverse Section.*

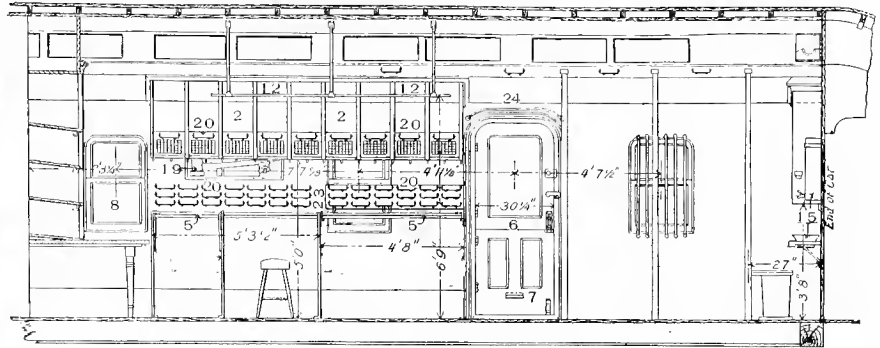

Fig. 610. *Longitudinal Section.*

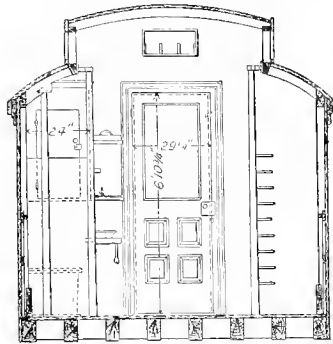

Fig. 611. *Transverse Section.*

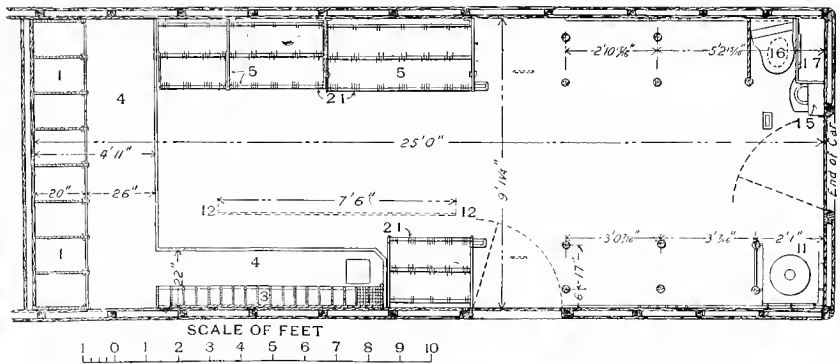

Fig. 612. *Plan.*

TWENTY FIVE-FOOT MAIL COMPARTMENT OF A COMBINATION BAGGAGE AND MAIL CAR. PENNSYLVANIA RAILROAD.

Approved by U. S. Railway Mail Service, Second Division.

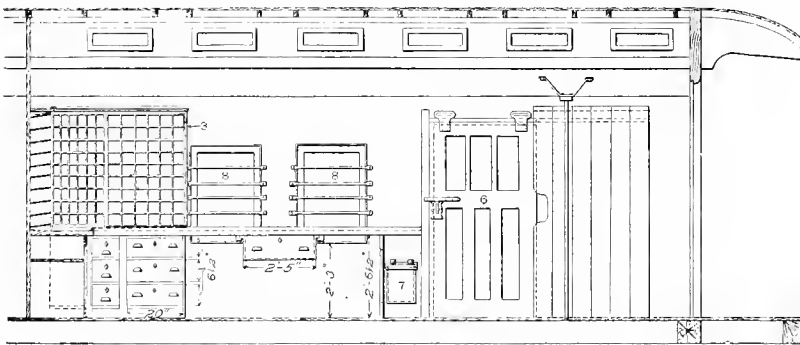

Fig. 613. *Sectional Elevation of Interior.*

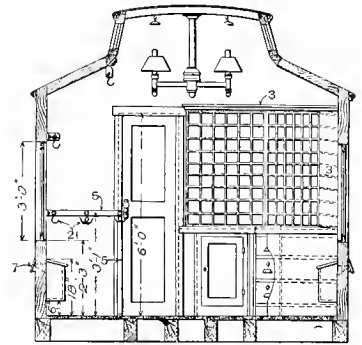

Fig. 614. *Transverse Section.*

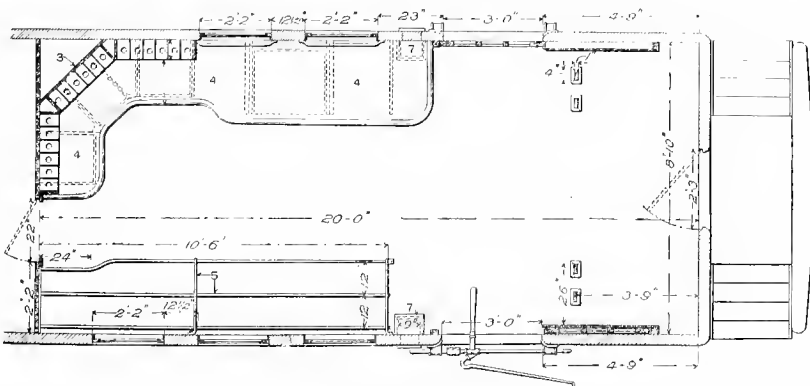
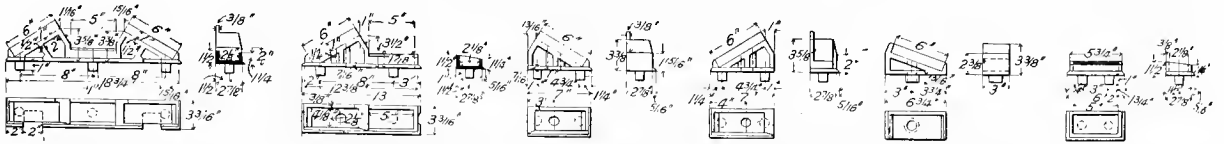

Fig. 615. *Sectional Plan.*

(111)

TWENTY-FOOT MAIL COMPARTMENT OF A COMBINATION BAGGAGE AND MAIL CAR. OLD COLONY RAILROAD.



Figs. 696-698. Double Brace and Post Casting (4). Figs. 699-701. Single Brace and Post Casting (4). Figs. 702-704. Side Brace Casting at Corner Post (4). Figs. 705-707. Side Brace Casting at Door Post (4). Figs. 708-710. End Brace Casting (5). Figs. 711-713. Side Post Socket Casting (4).

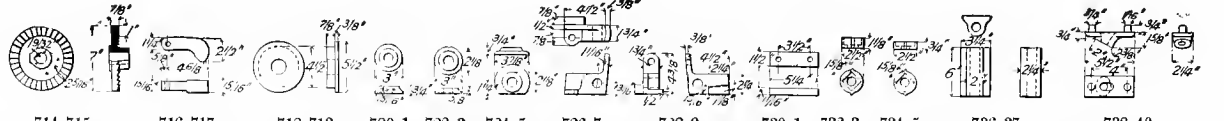

714-715. Brake Shaft Ratchet (1). Figs. 716-717. Pawl Weight (1). Figs. 718-19. Body Truss Rod Washers (4). Figs. 720-1. Washer (4). Figs. 722-3. Washer (1). Figs. 724-5. Washer (1). Figs. 726-9. Uncoupling Locks (2). Figs. 730-1. Uncoupling Lever Gear Plates (2). Figs. 732-3. Washer. Figs. 734-5. Washer. Figs. 736-7. Draw Timber Guards (4). Figs. 738-40. Angle Rod Bevel Washer (8).

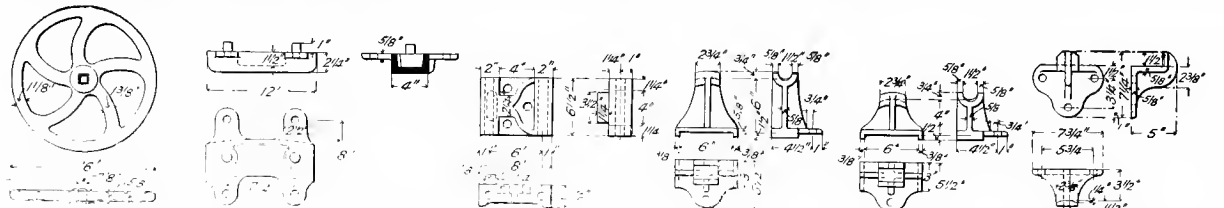

Figs. 741-2. Hand Brake Wheel (1). Figs. 743-4. Body Side Bearing (1). Figs. 745-7. Draw Bar Stop Castings (8). Figs. 748-50. Body Truss Rod Saddles (4). Figs. 751-3. Body Truss Rod Saddles (4). Figs. 751-6. Door Guide Brackets (2).

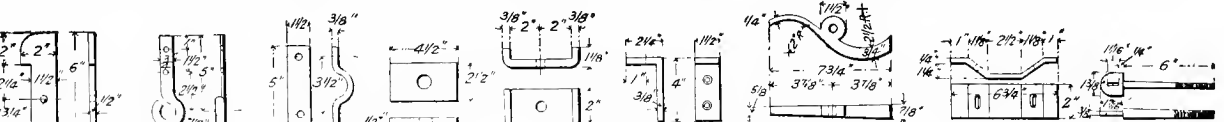

Figs. 757-8. King Bolt Keys (2). Figs. 759-60. Relief Valve Rod Guides (2). Figs. 761-2. Lever Bearings (2). Figs. 763-4. Body Rod Washers (8). Figs. 765-6. Needle Beam Angle Irons (13). Figs. 767-8. Brake Pawl (1). Figs. 769-70. Brake Rod Washer (1). Figs. 771-2. Brake Rod Washer (1). Figs. 773-4. Eye Bolts (2).

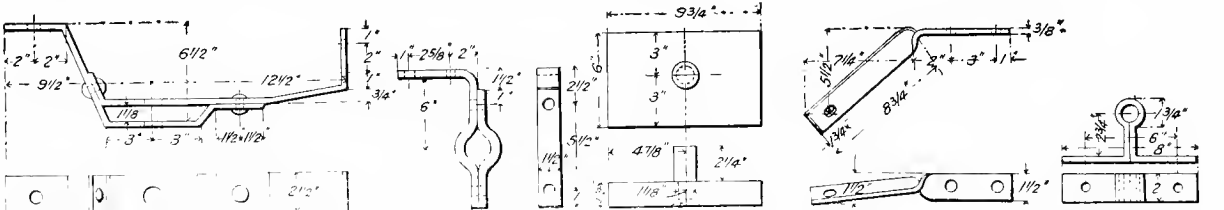

Figs. 775-6. Floating Lever Fulcrum (1). Figs. 777-8. Pipe Clamps (2). Figs. 779-80. Follower Plates (4). Figs. 781-2. Hose Hook Coupling Iron (2). Figs. 783-81. Shaft Collar (1).

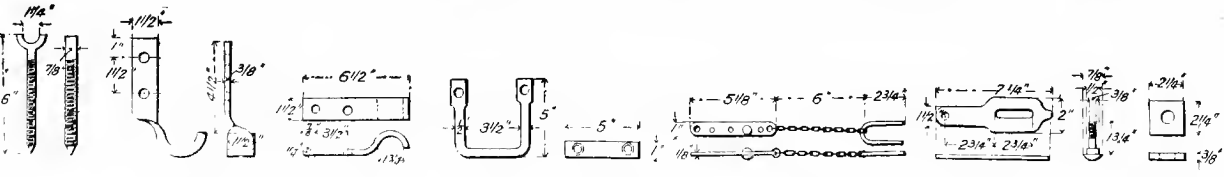

785-6. Shaft Bearing (1). Figs. 787-8. Pipe Loop-Hanger (1). Fig. 792. Door Chafing Plate (2). Figs. 789-90. Pipe Clamp (2). Figs. 791. Upper Brake-Connection (1). Figs. 793-4. Door Keys and Chains. Figs. 795-6. Door Hasps (2). Fig. 797. Door Buttons (2). Figs. 798-9. Body Rod Washer (8).

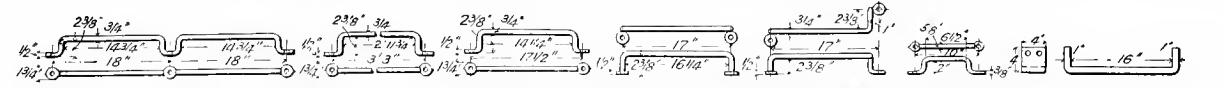

Figs. 800-1. End Double Grab-iron (1). Figs. 802-3. End Grab-iron (2). Figs. 801-5. Corner Grab-iron (2). Figs. 806-7. Ladder Round (10). Figs. 808-9. Ladder Round (2). Figs. 810-1. Door Handle (2). Figs. 812-13. Body Bolster Side Bearing (4).

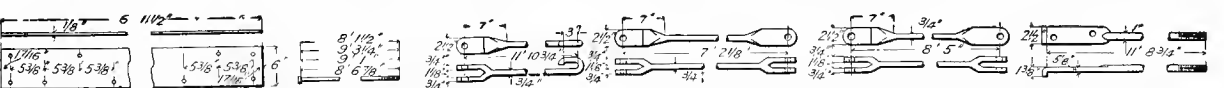

Figs. 814-15. Closed-door Guards (1). Fig. 816. Door post-rod. Figs. 817-18. Hand Brake-rod (1). Figs. 819-20. Truss-rod (2). Figs. 821-2. Cylinder Lever Rod (1). Figs. 823-24. Draw Timber Tie-rod (2).

Figs. 825-915. CAR-BODY DETAILS, Box-Cars; Wrought Iron and Steel.

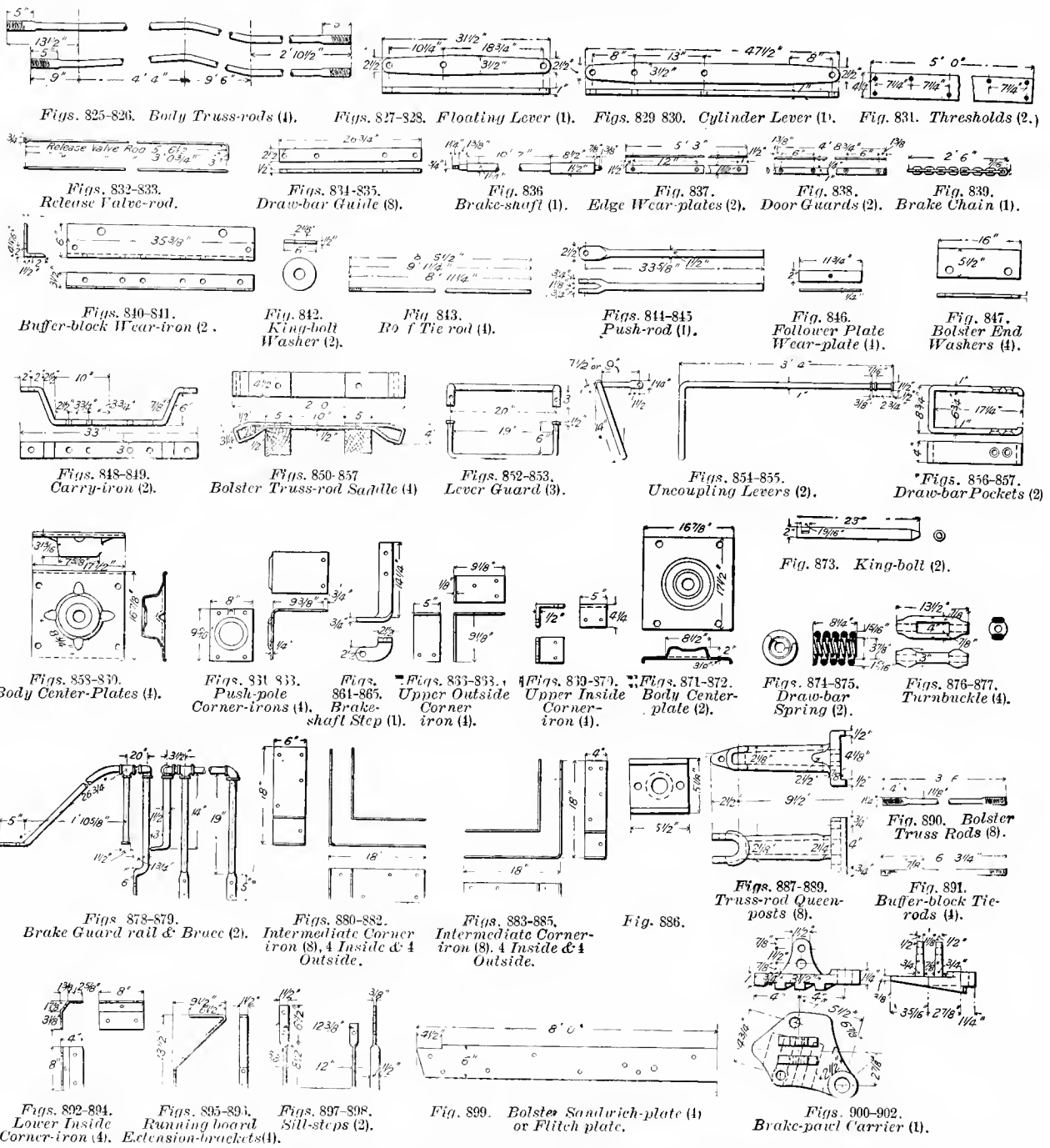

WROUGHT-IRON DETAILS FOR BOX-CAR BODY. NEW YORK CENTRAL & HUDSON RIVER RAILROAD.
Working Drawings are shown in Figs. 229-231.

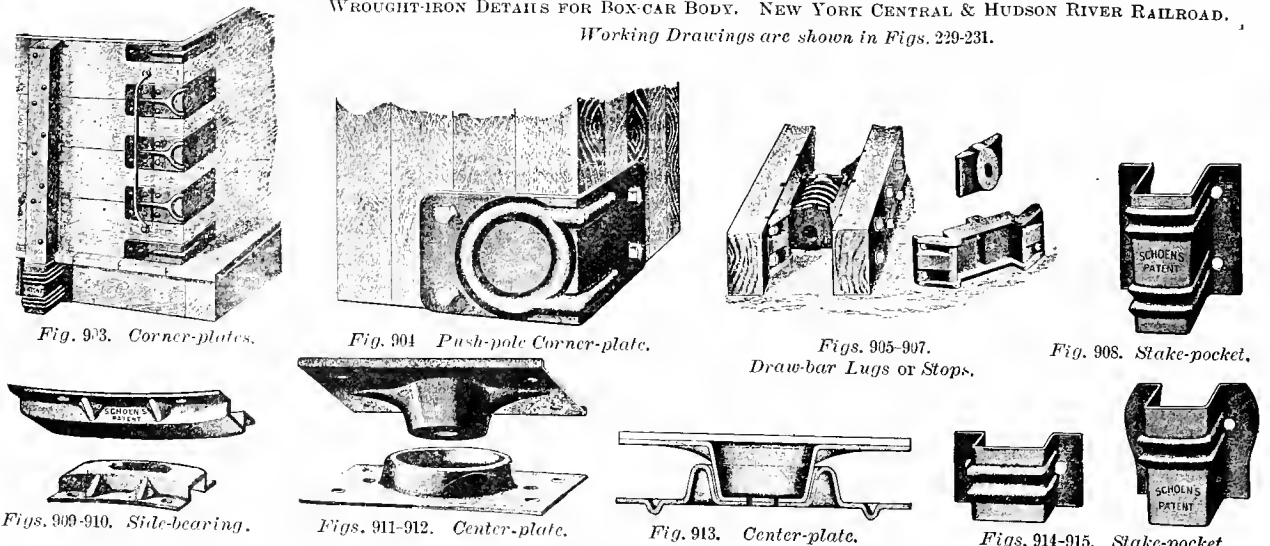

DETAILS OF PRESSED STEEL DETAIL PARTS OF FREIGHT CARS.

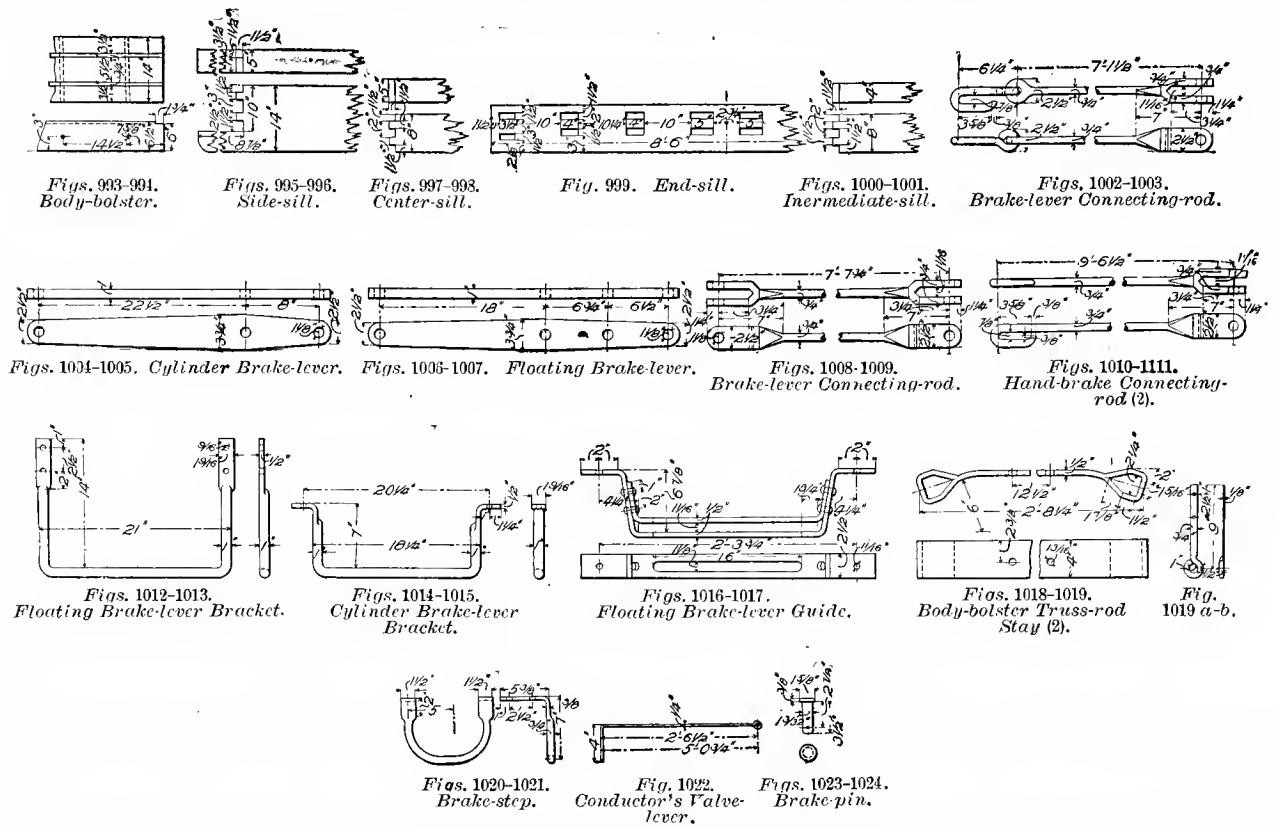

DETAILS OF WOOD AND WROUGHT-IRON PARTS OF 60,000-LB. FLAT CAR. NEW YORK, LAKE ERIE & WESTERN RAILROAD. (Car Body is shown in Figs. 287-289.)

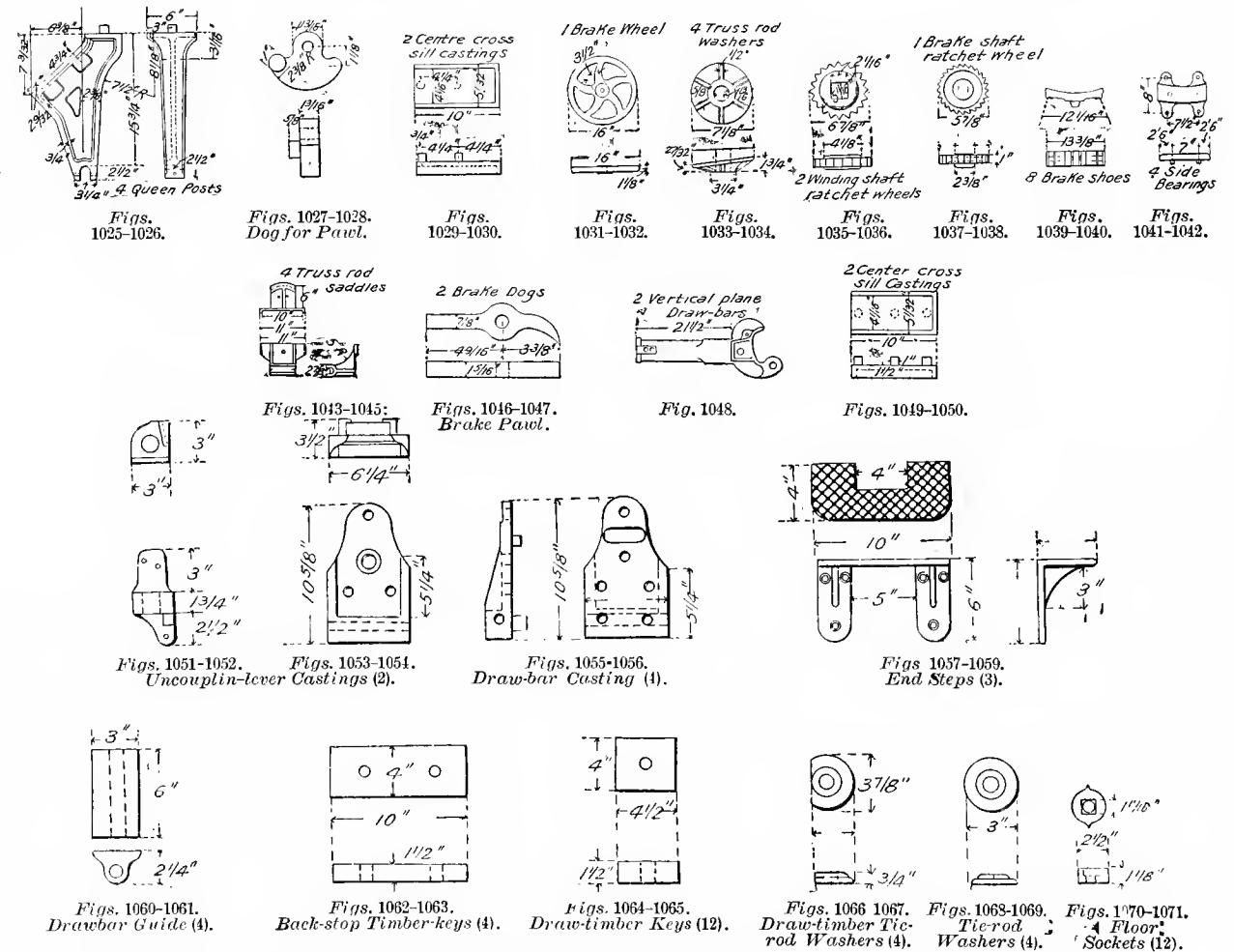

DETAILS OF CAST-IRON PARTS OF TWIN-HOPPER GONDOLA-CAR BODY. NEW YORK CENTRAL & HUDSON RIVER RAILROAD. Length, 35 ft. 6 in. Capacity, 60,000 lbs.

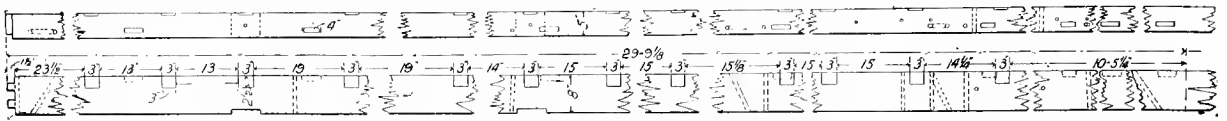

Figs. 1176-1177. Side-sill (2).

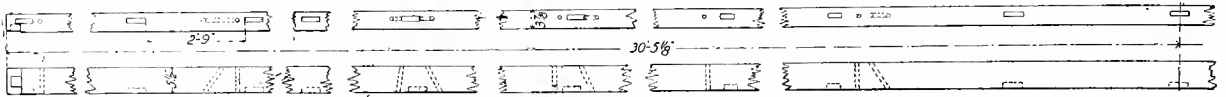

Figs. 1178-1179. Side-plate (2).

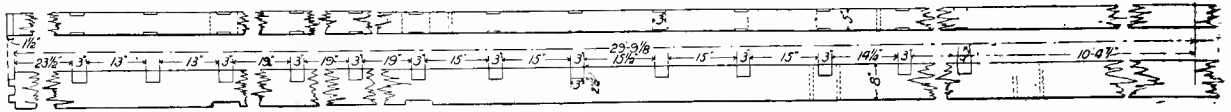

Figs. 1180-1181. Intermediate-sill (4).

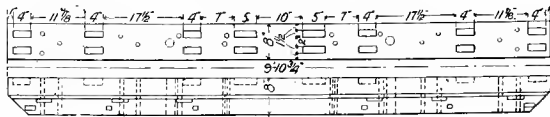

Figs. 1182-1183. End-sill (2).

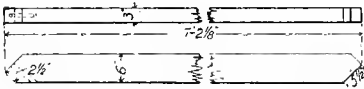

Figs. 1184-1185. Side-brace, 2 R & 2 L, 2d from End (4).

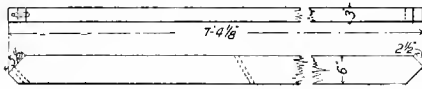

Figs. 1186-1187. Side-brace, 2 R & 2 L, 3d & 4th from End (8).

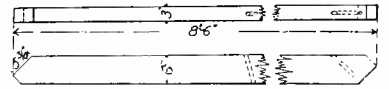

Figs. 1188-1189. Side-brace, 2 R & 2 L, 1st from End (4).

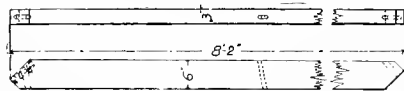

Figs. 1190-1191. Side-brace, 2 R & L, Between Side-doors.

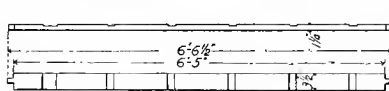

Figs. 1192-1193. Lag-post (4), 2 R & 2 L.

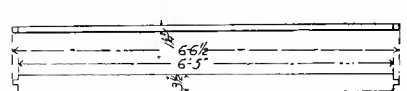

Figs. 1194-1195. Lag-post (12).

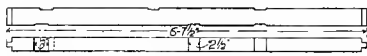

Figs. 1196-97. Side-post (4).

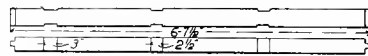

Figs. 1198-1199. Side-post (26).

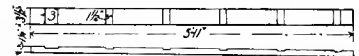

Figs. 1200-1201. Lag-post (12).

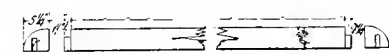

Figs. 1202-1204. End Door post (4), 2 R & 2 L.

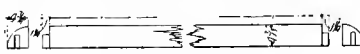

Figs. 1205-1207. Side Door post (4), 2 R & 2 L.

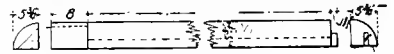

Figs. 1208-1210. Corner post (4), 2 R & 2 L.

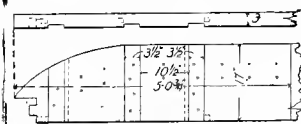

Figs. 1211-1212. End plate (2).

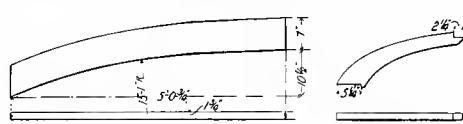

Figs. 1213-1214. End-carlines (2).

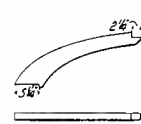

Figs. 1215-1216. Rafter (96).

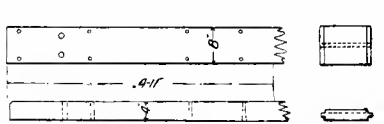

Figs. 1217-1218. Cross frame, Tie-timbers (4).
Figs. 1219-1220. Dome-posts (56).

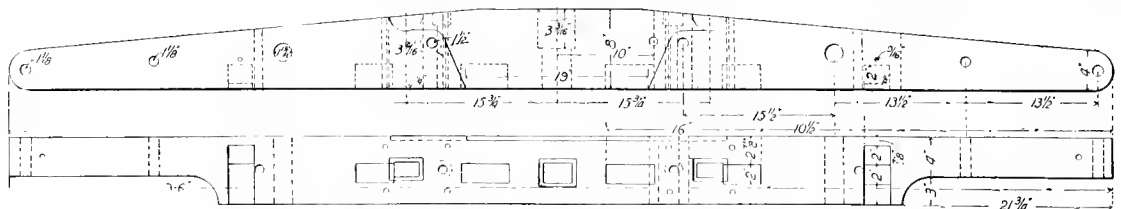

Figs. 1221-1222. Platform End-timbers (2).

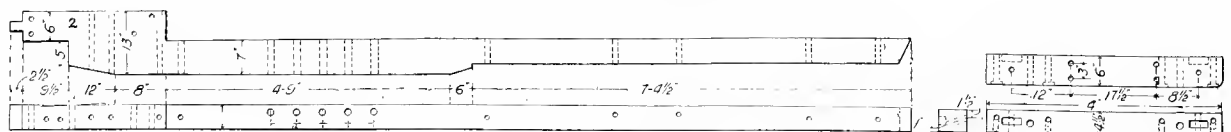

Figs. 1223-1224. Draw-timbers (4), 2 R & 2 L.

Figs. 1225-1227. Platform Truss-rod Block (2).

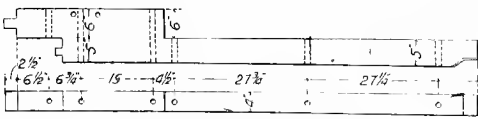

Figs. 1228-1229. Intermediate Platform-timber (4)

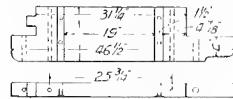
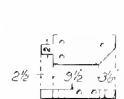

Fig. 1230-1231. Step Timbers, 2 rights and 2 lefts.



Figs. 1232-1234. Buffer block (2)



Figs. 1235-1236. Hanger block (2).

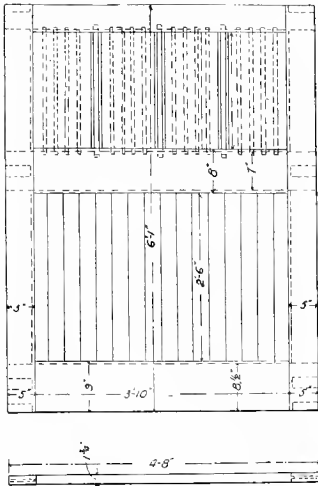
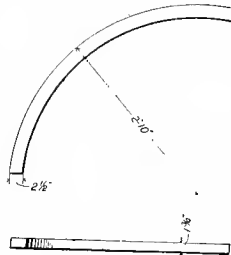

Fig. 1237-1238. Side-doors (2).



Figs. 1239-1240. Canopy Return-ribs.

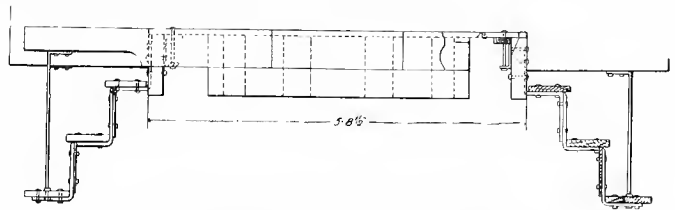
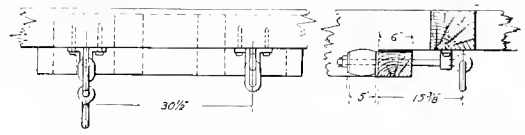
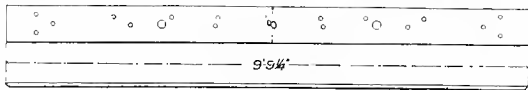

Fig. 1241. Application of Steps and Platform.



Figs. 1242-1243 Application of Safety chains.



Figs. 1244-1245. End-sill Flitch-plate 2

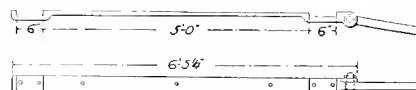

Figs. 1246-1247. Truss-rod Anchor-irons (4).

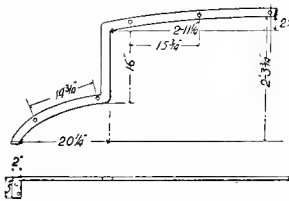

Figs. 1248-1249. Carline-plate (10).

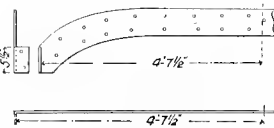

Figs. 1250-1251. End-plate Stiffener (2).

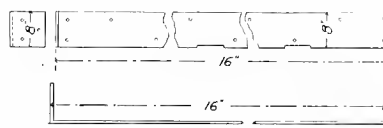

Figs. 1252-1254. Side-sill Flitch-plate (4).

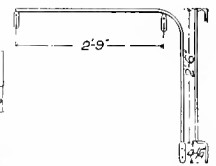

Figs. 1255-1256. Platform Hand-rail (4).

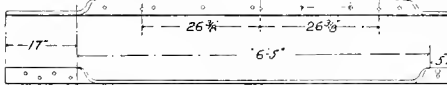

Figs. 1257-1258. End-stiffener (8).

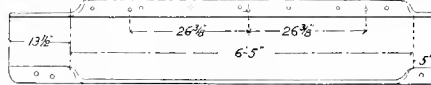

Figs. 1259-1260. End-stiffener (4).

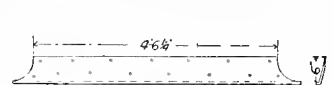

Figs. 1261-1262. Side-door Threshold (4).

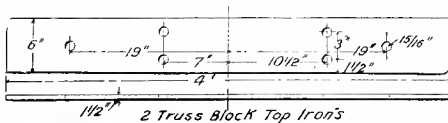

Figs. 1263-1264.

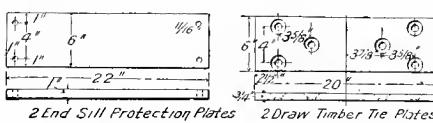

Figs. 1265-1266.

Figs. 1267-1268.

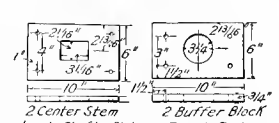

Figs. 1269-1270. Figs. 1271-1272.

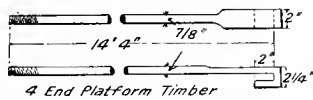

Figs. 1273-1274. Platform Timber Tie-rod (4).

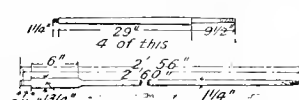

Figs. 1275-1276. Platform Post and Brake-shaft (4 of each).

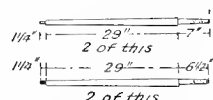

Figs. 1278-1279. Platform-post (2 of each).

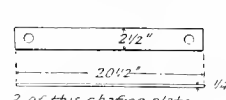

Figs. 1280-1281. Chafing-plate (2).

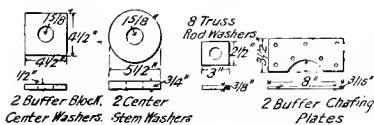

Figs. 1282-1283. Figs. 1284-1285. Figs. 1286-1287. Figs. 1288-1289.

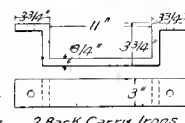

Figs. 1290-1291. Carry-iron (2).

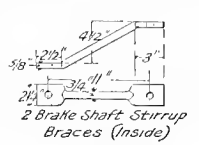

Figs. 1292-1293. Brake-shaft Stirrup Braces (2 of each).

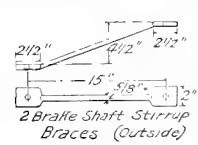

Figs. 1294-1295. Brake-shaft Stirrup Braces (2 of each).

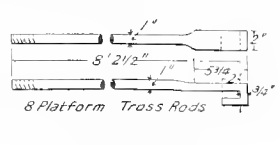

Figs. 1296-1297. Platform Truss-rod (8).

DETAILS OF WOOD AND WROUGHT-IRON PARTS OF BAGGAGE-CAR BODY. NEW YORK CENTRAL & HUDSON RIVER RAILROAD.

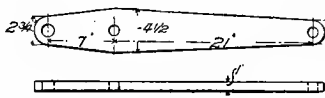

Figs. 1361-1365.
Intermediate Lever.

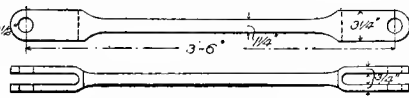

Figs. 1366-1367.
Connecting Cylinder-rod.

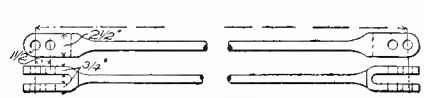

Figs. 1368-1369.
Floating-lever Connecting-rod.

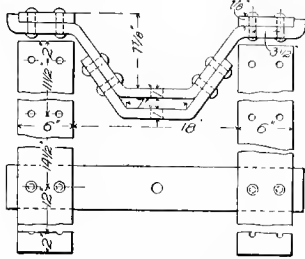

Figs. 1370-1371. Lever Fulcrum.

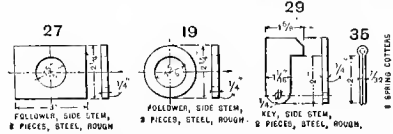

Figs. 1373-1376.
Side-stem Follower.

Figs. 1377-1379.
Side-stem Spring Collar.

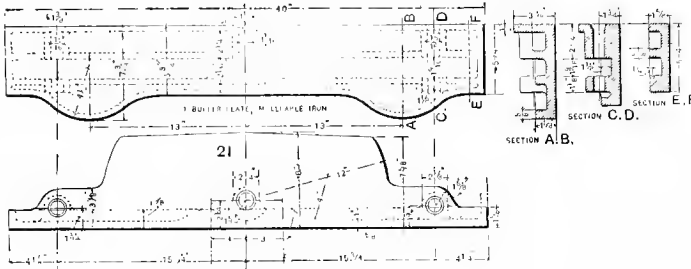

Figs. 1380-1384.
Buffer Plate, Malleable Iron.

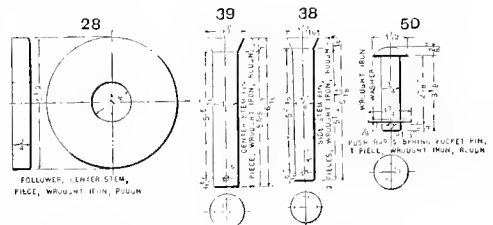

Figs. 1385-1388.
Center-stem Follower.

Figs. 1387-1392.
Pins for Stems and Push-bar.

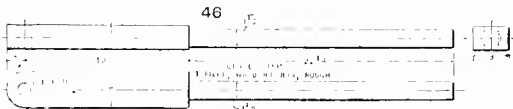

Figs. 1393-1394. Center-stem.

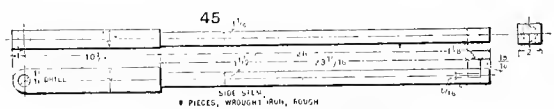

Figs. 1395-1396. Side-stem.

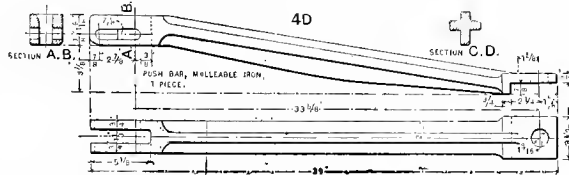

Figs. 1397-1398. Push-bar, Malleable Iron

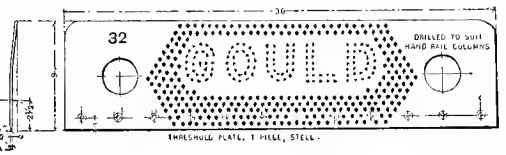

Figs. 1399-1400. Threshold-plate.

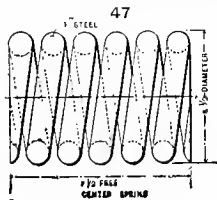

Fig. 1401. Center-spring.

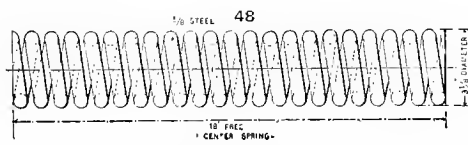

Fig. 1402.
Long Center-spring

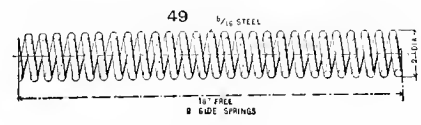
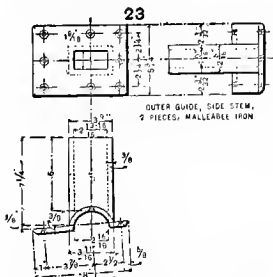
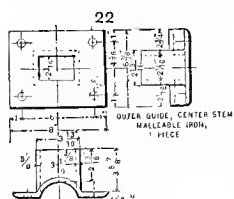

Fig. 1403.
Side-spring



Figs. 1404-1406. Outer Side-stem Guide.



Figs. 1407-1409. Outer Center-stem Guide.

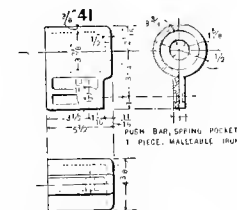

Figs. 1410-1412.
Push-bar Spring-pocket.

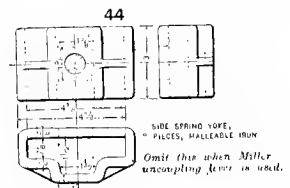

Figs. 1413-1415.
Side-spring Yoke.

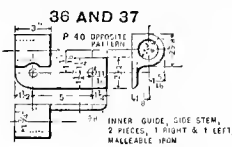

Figs. 1416-1418. Inner Side-stem Guide.



Figs. 1419-1420.
Name-plate.

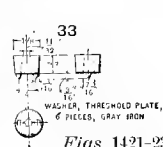

Figs. 1421-23.
Threshold-plate Washer.

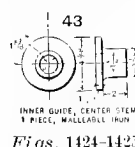

Figs. 1424-1425.
Center-stem Inner-guide.

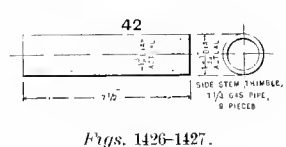

Figs. 1426-1427.
Side-stem Thimble.

DETAILS OF WROUGHT AND CAST IRON PARTS OF BRAKE-GEAR AND DRAFT-GEAR OF BAGGAGE-CAR BODY.
NEW YORK CENTRAL & HUDSON RIVER RAILROAD
(Gould Draft-gear.)

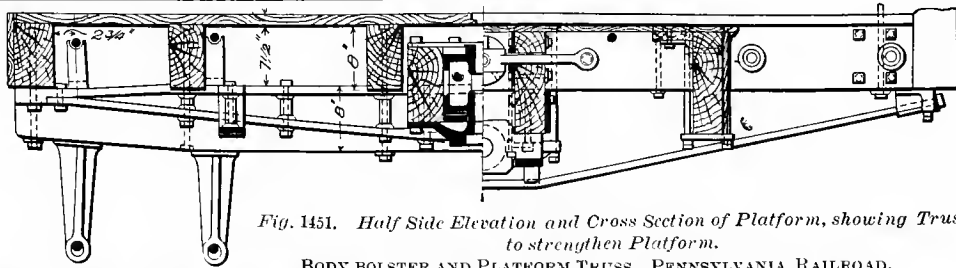

Fig. 1451. Half Side Elevation and Cross Section of Platform, showing Truss to strengthen Platform.

BODY BOLSTER AND PLATFORM TRUSS. PENNSYLVANIA RAILROAD.

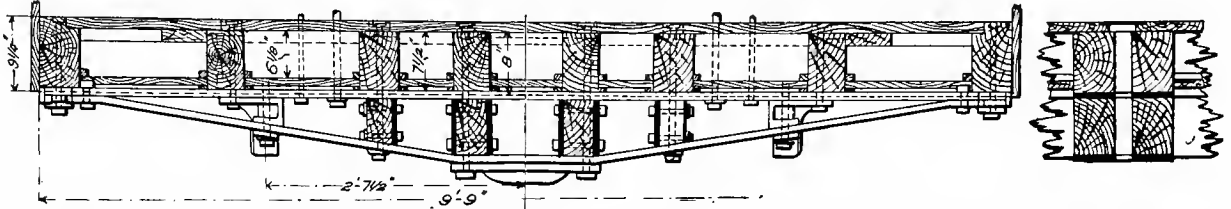

Fig. 1452. Cross Section of Underframe. Draft-timbers and Platform-sills are Plated to strengthen Platform.

Fig. 1453. Cross Section of Bolster.

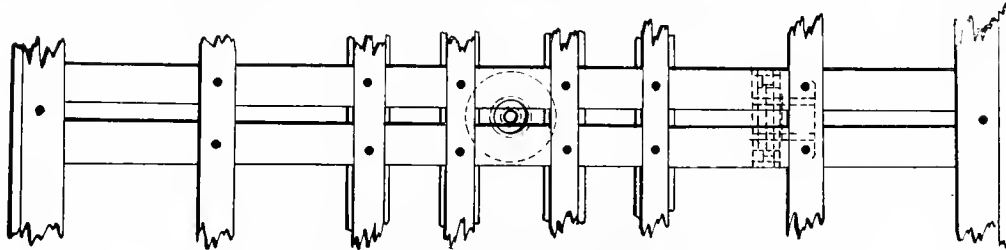

Fig. 1454. Plan of Bolster and Sills. DOUBLE BODY-BOLSTER, PASSENGER. NORFOLK & WESTERN RAILROAD.

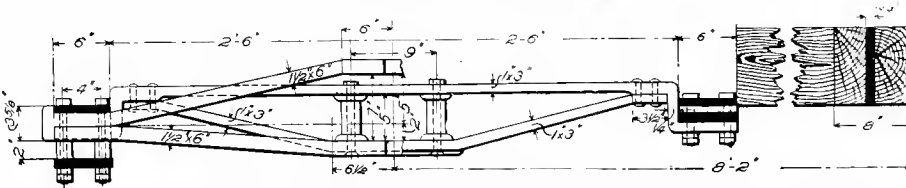

Fig. 1455. Cross Section of Bolsters, Half Elevation of Center-plate Truss and Full Elevation of Side-bearing Truss.

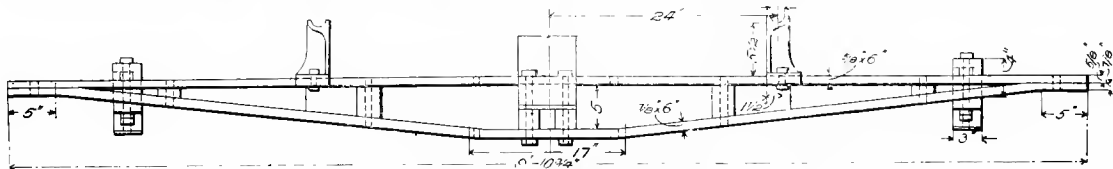

Fig. 1456. Elevation of Bolster.

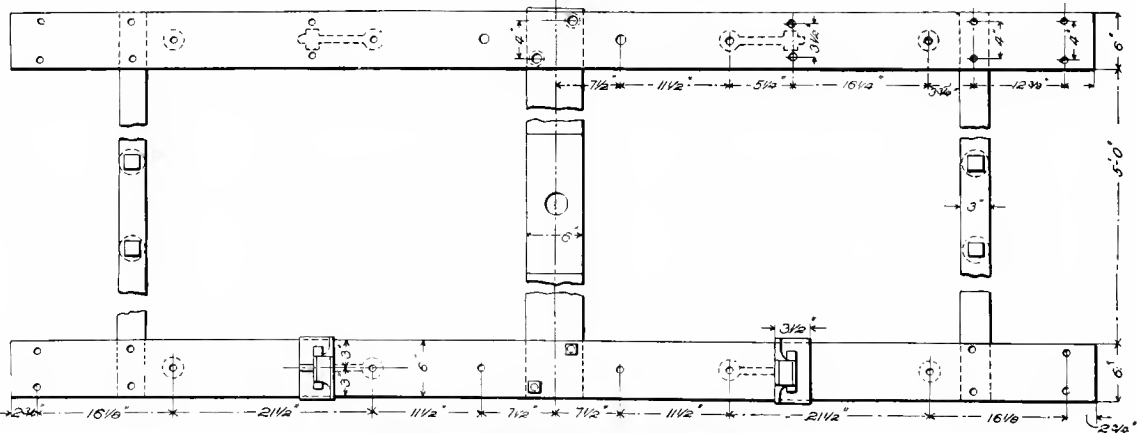

Fig. 1457. Plan of Bolster and Connecting Trusses. DOUBLE BODY-BOLSTER AND LONGITUDINAL TRUSSES BETWEEN, FOR CENTER-PLATE AND SIDE-BEARINGS. NEW YORK CENTRAL & HUDSON RIVER RAILROAD.

NAMES OF PARTS OF BODY-BOLSTERS, FREIGHT. Figs. 1428-1434.

- | | | | |
|-----------------------------|-------------------------|-------------------------------|-------------------------------|
| 1. Top-plate. | 6. Outer Thimble-bolt. | 11. Body Center-plate. | 15. Body Truss-rod. |
| 2. Bottom-plate. | 7. End-bolt. | 12. Truck Center-plate. | 16. Truck-bolster |
| 3. Thimble. | 8. Side-sill Bolt. | 13. King-bolt. | 17. Sill-bolt (Intermediate). |
| 4. Outer-thimble, or Wedge. | 9. Body Side-bearing. | 14. Truss-rod Bearing-saddle. | 18. Center-sill Bolt. |
| 5. Thimble-bolt. | 10. Truck Side-bearing. | | 4a. Intermediate Thimble. |

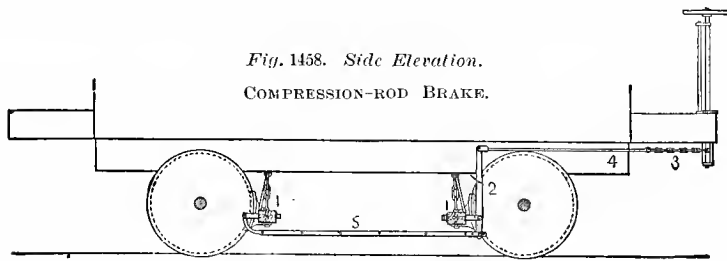

Fig. 1458. Side Elevation.
COMPRESSION-ROD BRAKE.

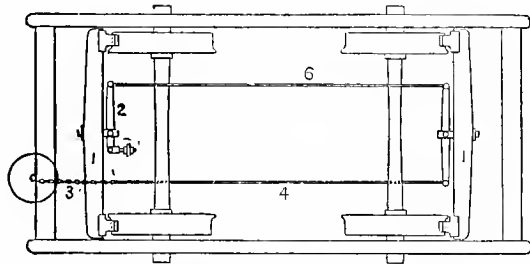

Fig. 1459. Plan.
BRAKE FOR SHORT DROP-BOTTOM CAR.

LIST OF NAMES OF PARTS OF BRAKES.

Figs. 1458-1463.

1. Brake-beam.
2. Brake-lever (Dead-lever and Live-lever).
3. Brake-shaft Chain.
4. Brake-shaft Connecting-rod.
5. Lower Brake-rod.
6. Secondary Brake-rod.
7. Floating-lever.
8. Floating Connecting-rod.
9. Center Brake-lever.
10. Center Brake-lever Chain.
11. Center Brake-lever Sheaves.
12. Dead-lever Brake-rod.

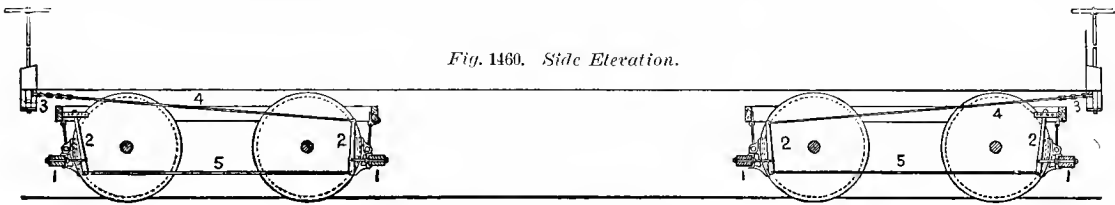

Fig. 1460. Side Elevation.

DOUBLE-LEVER BRAKE.

(Rarely used when brakes are applied to both trucks.)

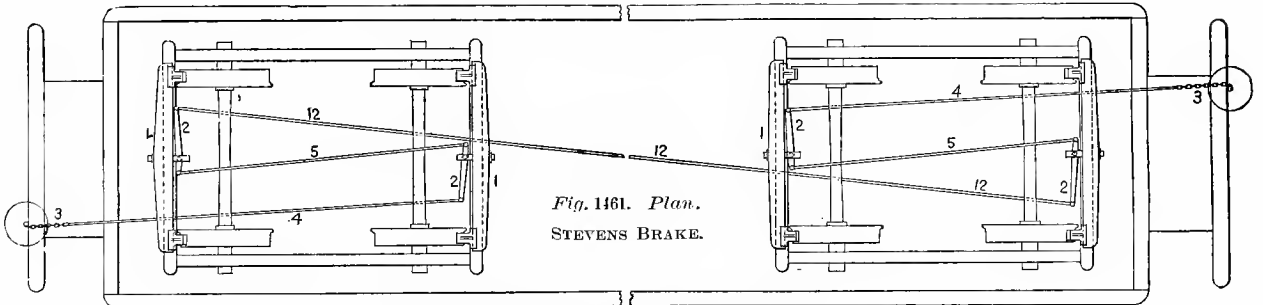

Fig. 1461. Plan.
STEVENS BRAKE.

(Not much in use, occasionally met with.)

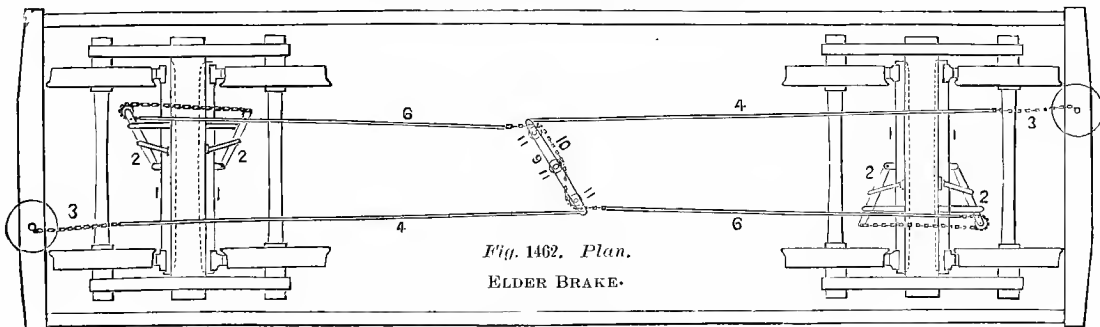

Fig. 1462. Plan.
ELDER BRAKE.

(Is not being applied to new construction.)

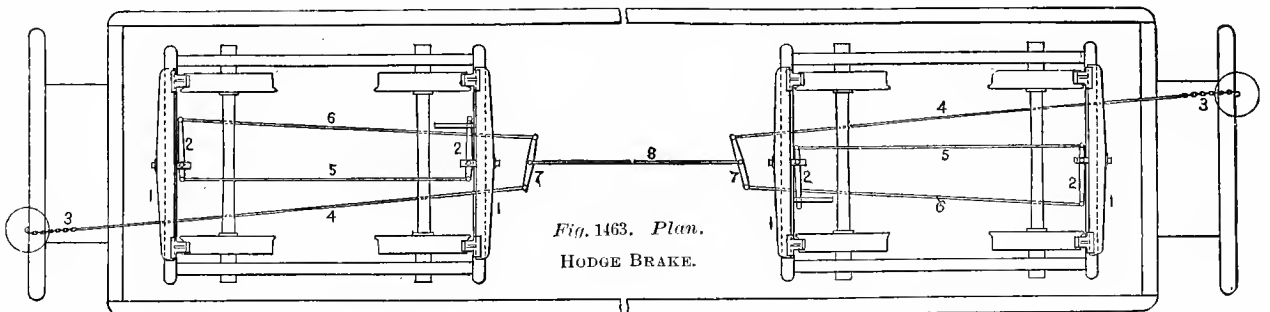
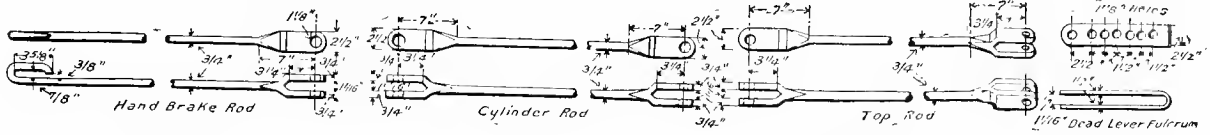

Fig. 1463. Plan.
HODGE BRAKE.



Figs. 1514-1515.

Figs. 1516-1517.

Figs. 1518-1519.

Figs. 1520-1521.

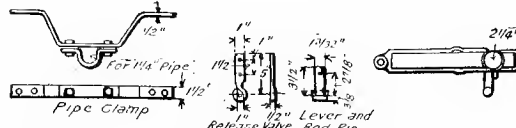

Figs. 1522-1523.

Figs. 1524-1525.

Fig. 1527.

DETAILS OF FOUNDATION FREIGHT BRAKE GEAR ADOPTED BY THE MASTER CAR BUILDERS' ASSOCIATION 1889, 1890 AND 1891.

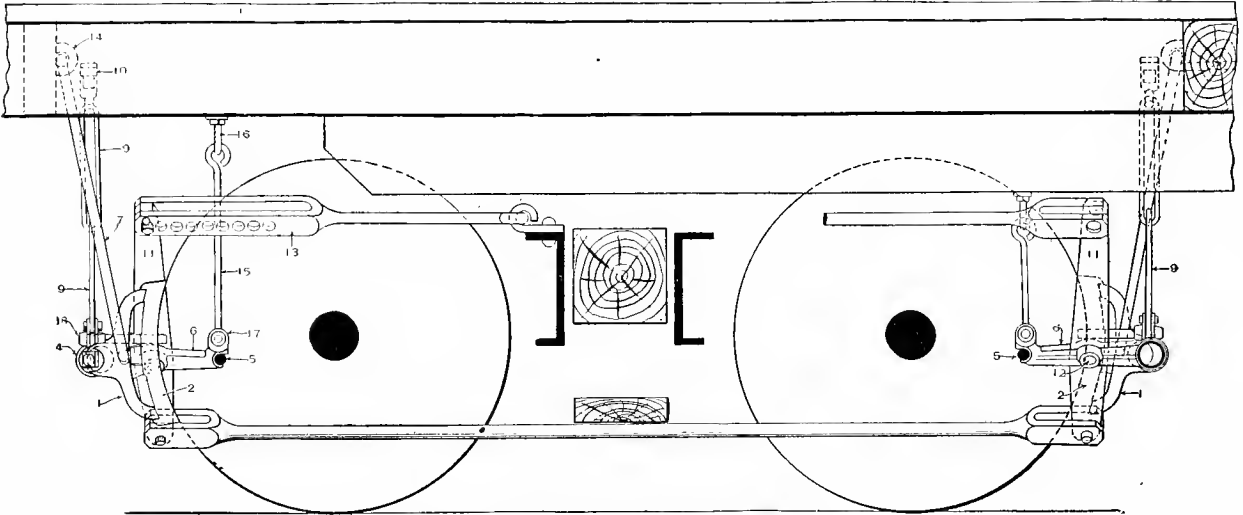

Fig. 1528. Sectional Side Elevation.

DIAMOND TRUCK, BRAKES OUTSIDE-HUNG FROM THE CAR-BODY.

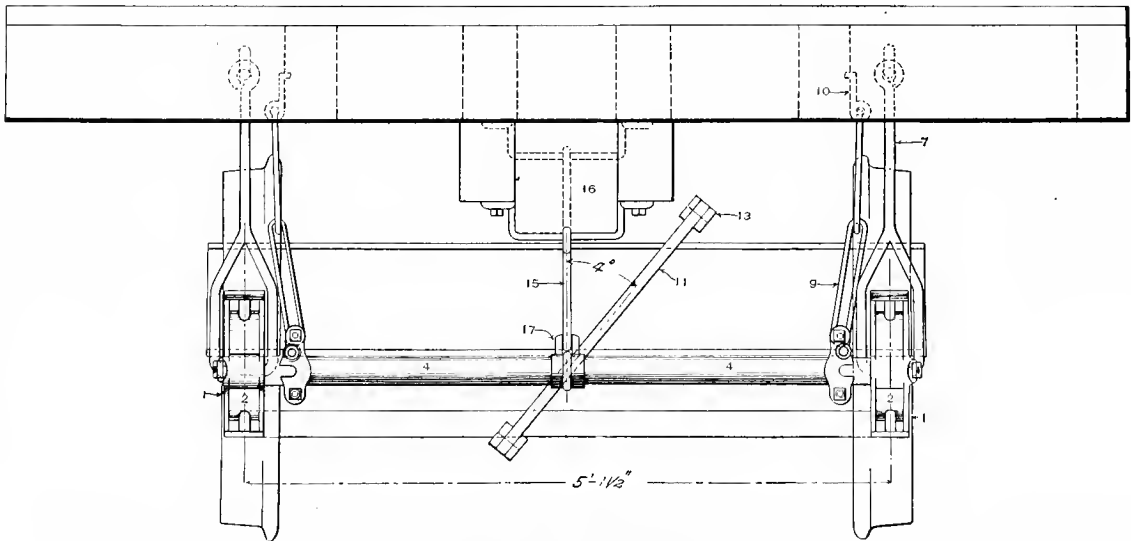

Fig. 1529. End Elevation.

DIAMOND TRUCK, BRAKES OUTSIDE-HUNG FROM THE CAR-BODY.

NAMES OF PARTS OF FREIGHT BRAKE GEAR. Figs. 1528-1529.

- | | |
|--------------------------------|--------------------------------------|
| 1. Brake-block. | 10. Brake Safety-chain Eye-bolt. |
| 2. Brake-shoe. | 11. Brake-lever. |
| 3. Brake shoe Key. | 12. Brake lever Fulcrum. |
| 4. Trussed Brake-beam. | 13. Brake lever Stop. |
| 5. Brake-beam Truss rod. | 14. Brake-hanger Bearing. |
| 6. Brake-beam King-post. | 15. Brake-beam Adjusting-hanger. |
| 7. Brake hanger. | 16. Brake beam Adjusting-carrier. |
| 8. Brake-hanger Carrier. | 17. Brake-beam Adjusting-hanger Eye. |
| 9. Brake Safety-chain or Link. | |

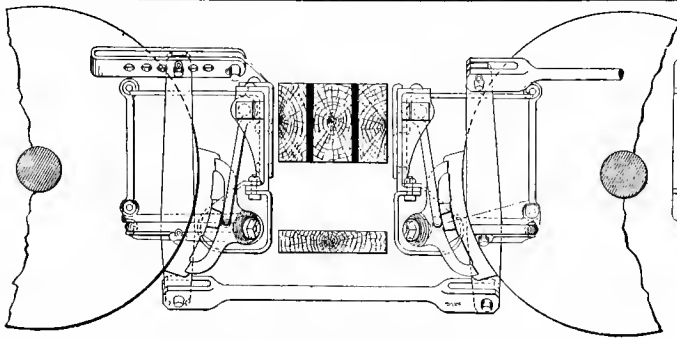

Fig. 1530. Sectional Side Elevation.

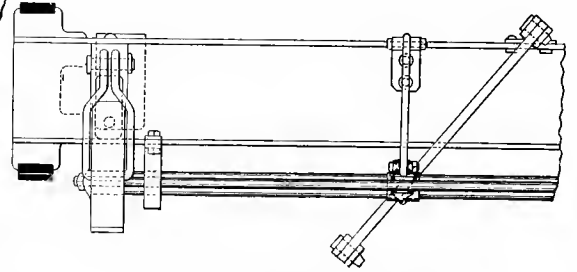

Fig. 1531. Sectional End Elevation.

BRAKE-GEAR, FREIGHT, FOR DIAMOND TRUCK.
Inside-hung from Channel-beam Transoms.

Brake Hand-rails, for use on top of Box Cars, are shown in Figs. 229-231, 244-246, and 878-879. Application of Air-brake to Gondola Cars is shown in Figs. 25, 310-311, 316-319. Other Inside-hung Brakes are shown under Trucks.

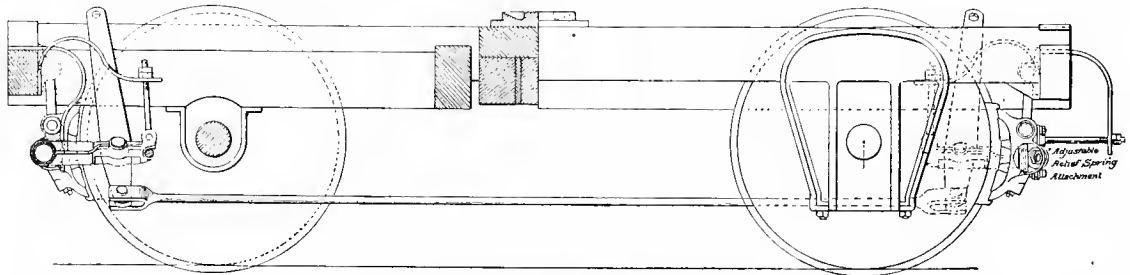

Fig. 1532. Sectional Side Elevation.
BRAKE-GEAR, PASSENGER, AS APPLIED TO FOUR-WHEELED TRUCK.
Wheels Braked upon One Side Only.

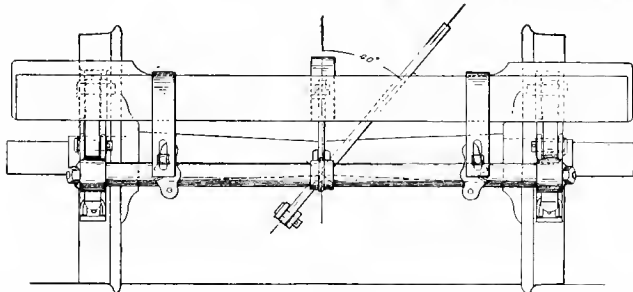

Fig. 1533. End Elevation.

BRAKE-GEAR, PASSENGER, AS APPLIED TO FOUR-WHEELED PASSENGER TRUCK.
Wheels Braked upon One Side Only.

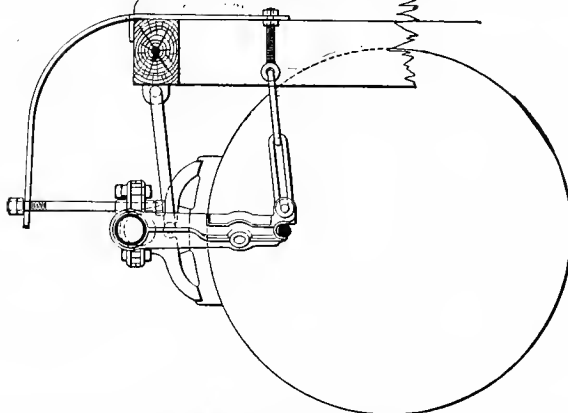

Fig. 1534. Part Side Elevation.

BRAKE-GEAR, PASSENGER, SHOWING ANOTHER MANNER OF HANGING-BRAKES.
Brakes Hung upon One Side of Wheel.

NAMES OF PARTS. Figs. 1535-1537.

1. Upper Brake-lever Connecting-rod.
2. Upper Brake-lever Connecting-rod Clevis.
3. Live Truck-lever.
4. Brake-lever Connecting-rod.
5. Truck Brake-lever.
6. Upper Lever-connecting-rod.
7. Dead Truck-lever.
8. Brake-beam.
9. Brake-beam Strut.
10. Brake-head.
11. Brake-shoe.
12. Brake Release-spring
13. Brake Safety-hanger.
14. Brake-beam Adjusting-hanger Carrier.
15. Brake-beam Adjusting-hanger.
16. Brake-lever Guide and Stop.
16. Brake-hanger.
17. Brake-hanger Bracket.

NAMES OF PARTS. Figs. 1540-1542.

- | | | |
|---|---|---|
| <ol style="list-style-type: none"> 1. Upper Brake-lever Connecting-rod. 2. Upper Brake-lever Connecting-rod Clevis. 3. Live Truck-lever. 4. Brake-lever Connecting-rod. 5. Brake-lever Hanger. | <ol style="list-style-type: none"> 6. Lower Brake Connecting-rod Safety-strap. 7. Auxiliary-brake Equalizing-lever. 8. Lower Brake Connecting-rod. 9. Lower Brake Connecting-rod. 10. Brake-beam Adjusting-hanger Carrier. | <ol style="list-style-type: none"> 11. Brake-beam Adjusting-hanger. 12. Brake-beam Hanger. 13. Brake-beam Safety-guard. 14. Brake-hanger Bracket. 17. Brake-lever Hanger-bridge. 18. Brake-lever hanger Clevis. |
|---|---|---|

Numbers Refer to List of Names of Parts on Opposite Page.

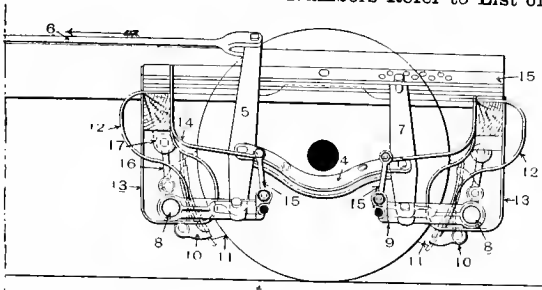

Fig. 1535. Half Side Elevation.

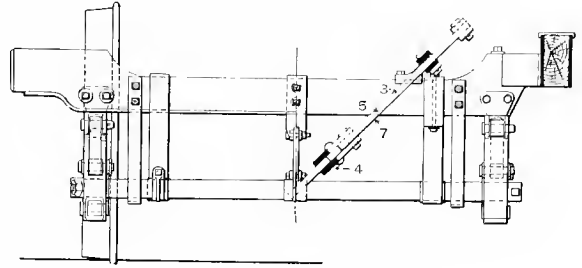

Fig. 1537. End Elevation.

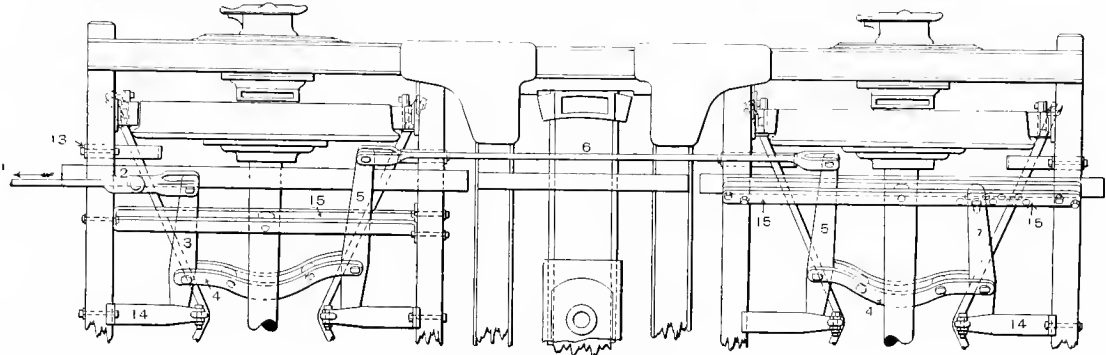

Fig. 1537. Half Plan.

BRAKE-GEAR, PASSENGER, AS APPLIED TO FOUR-WHEELED TRUCKS.
Brakes on Both Sides of Wheels.

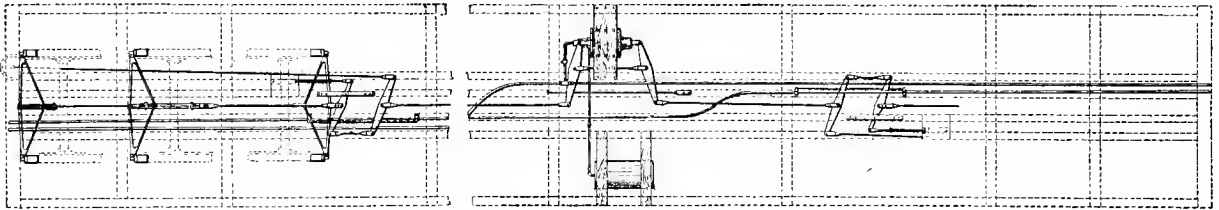

Fig. 1538. Plan.

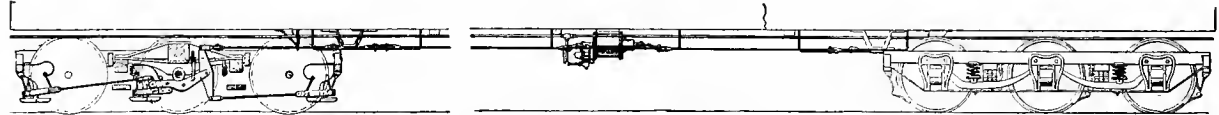

Fig. 1539. Sectional Side Elevation.
BRAKE-GEAR, PASSENGER.

Recommended by the Westinghouse Air Brake Company. Showing Arrangement of Body Gear and the Connections Between it and a Six-Wheeled Truck Brake Gear.

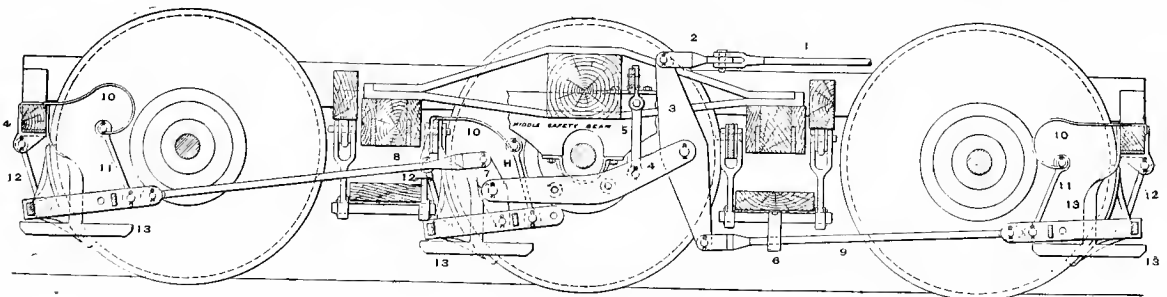

Fig. 1540. Sectional Side Elevation.

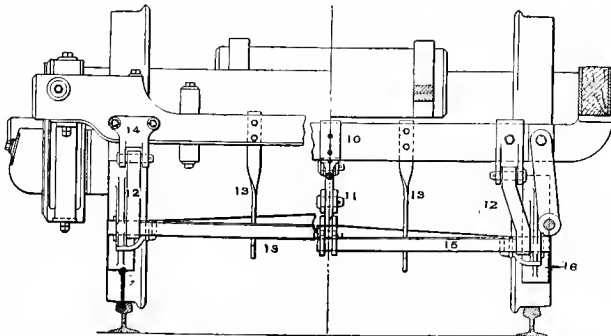

Fig. 1541. Half End Elevation and Half Cross Section.

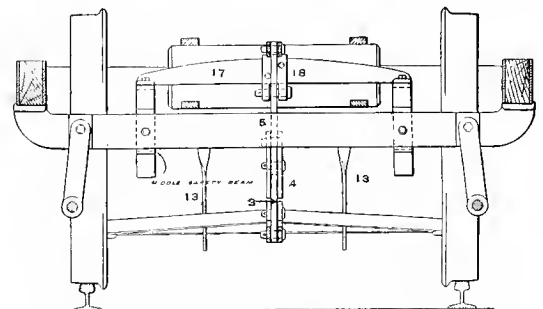

Fig. 1542. Transverse Section.

BRAKE-GEAR, PASSENGER, FOR SIX-WHEELED TRUCKS.
Recommended by the Westinghouse Air Brake Company.

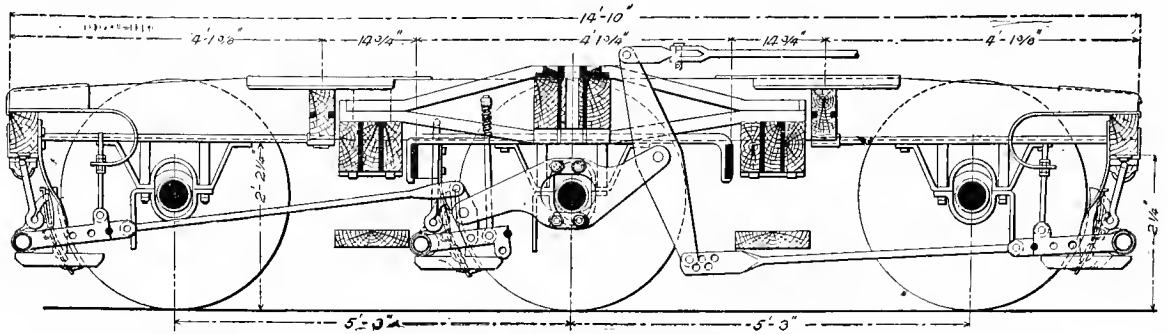

Fig. 1543. Sectional Side Elevation.

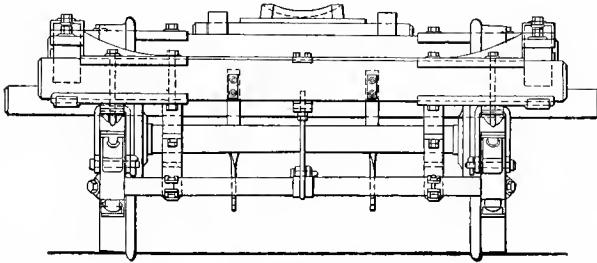

Fig. 1544. End Elevation.

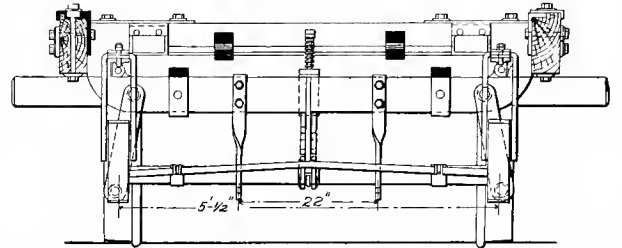
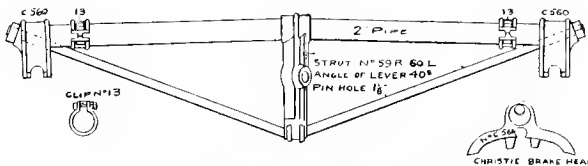

Fig. 1545. Transverse Section

BRAKE GEAR, PASSENGER, FOR SIX-WHEELED TRUCK.

An alternative design offered by the National Hollow Brake Beam Company.



Figs. 1546-1549. Standard Inside Hung Freight Beam with Clips.

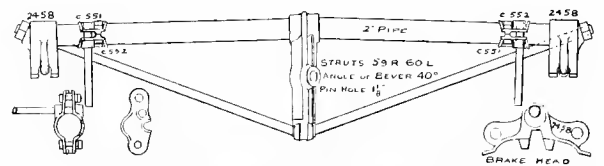

Figs. 1550-1552. Standard Outside Hung Freight Beam with Finger-Guards.

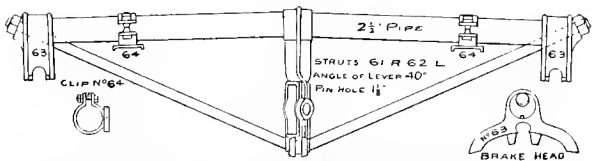

Figs. 1553-1555. Standard Rigid Head Beam for Passenger Cars and Locomotive Tenders.

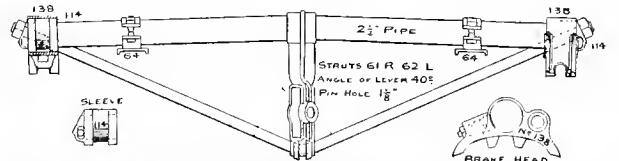

Figs. 1556-1560. Self-Adjusting Spring Head Beam for Passenger Cars and Locomotive Tender.

BRAKE BEAMS MADE BY NATIONAL HOLLOW BRAKE BEAM COMPANY.

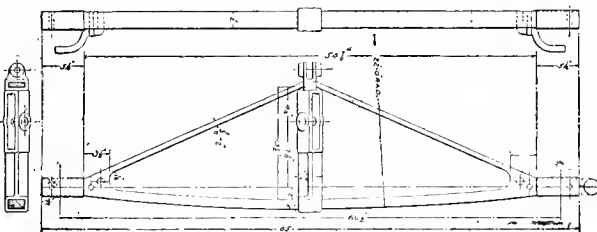

Figs. 1561-1564. Freight Brake Beam, Westinghouse.

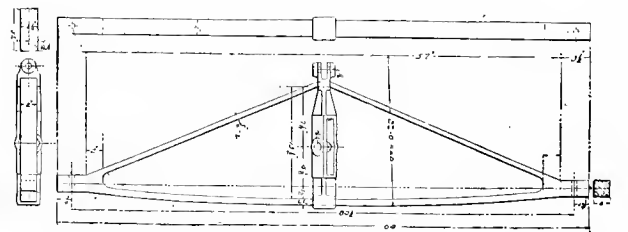

Figs. 1565-1567. Passenger Brake Beam, Westinghouse.

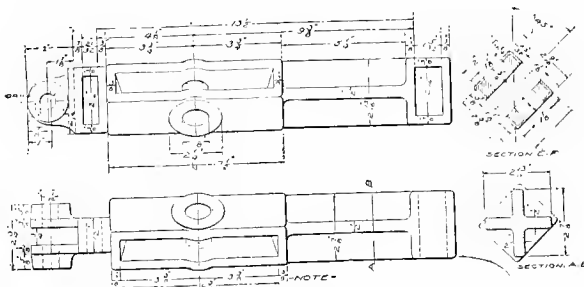

Figs. 1568-1571. Brake Beam Struts.

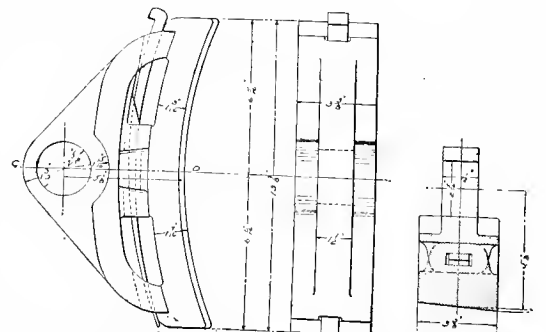

Figs. 1572-1574. Brake Head and Shoe.

BRAKE BEAMS, STRUTS AND HEADS. WESTINGHOUSE AIR BRAKE COMPANY.

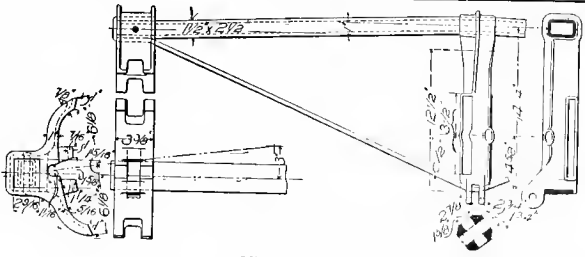

Figs. 1583-1586.

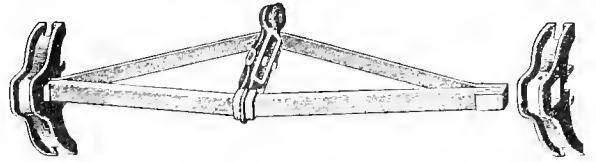

Figs 1581-1582.

THE KEWANEE STEEL BRAKE-BEAM AND BRAKE-HEAD,
For Passenger Cars and with Christie Heads.

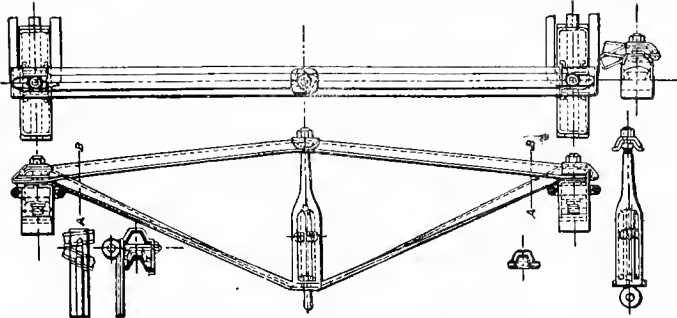

Figs. 1575-1580. Elevation and Plan.
THE SCHOEN PRESSED STEEL BRAKE-BEAM.

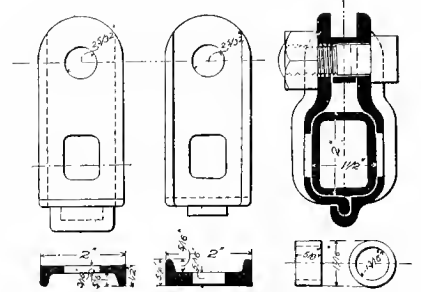

Figs. 1587-1593.
WHEEL-GUARD FOR KEWANEE STEEL BRAKE-BEAM.



Figs. 1594-1596. Perspective View.

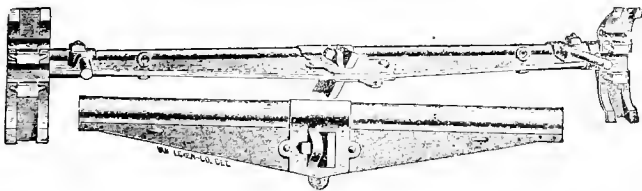

Figs. 1597-1598.
THE "DETROIT" STEEL BRAKE-BEAM.

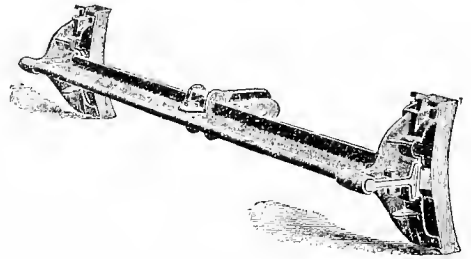

Fig. 1600.
THE MARDEN BRAKE-BEAM, WEIGHT 87 LBS.,
MADE BY MARDEN CAR BRAKE COMPANY.

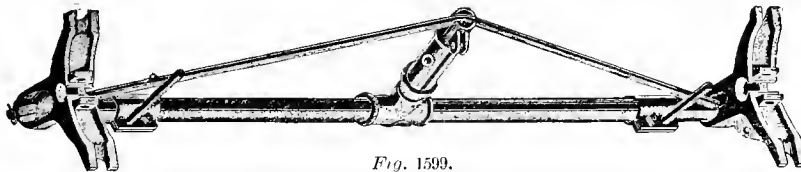

Fig. 1599.

THE UNIVERSAL STEEL BRAKE BEAM.

Figs. 1581-1599 are Made and Sold by the American Brake Beam Company.

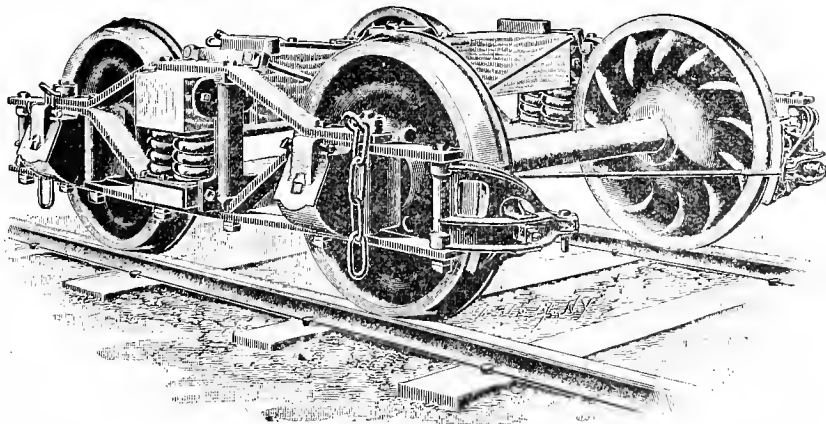

Fig. 1601.

BEAMLESS BRAKE RIGGING. BEAMLESS BRAKE COMPANY.
Showing Application of Brakes to a Truck Without the Use of a Brake-beam.

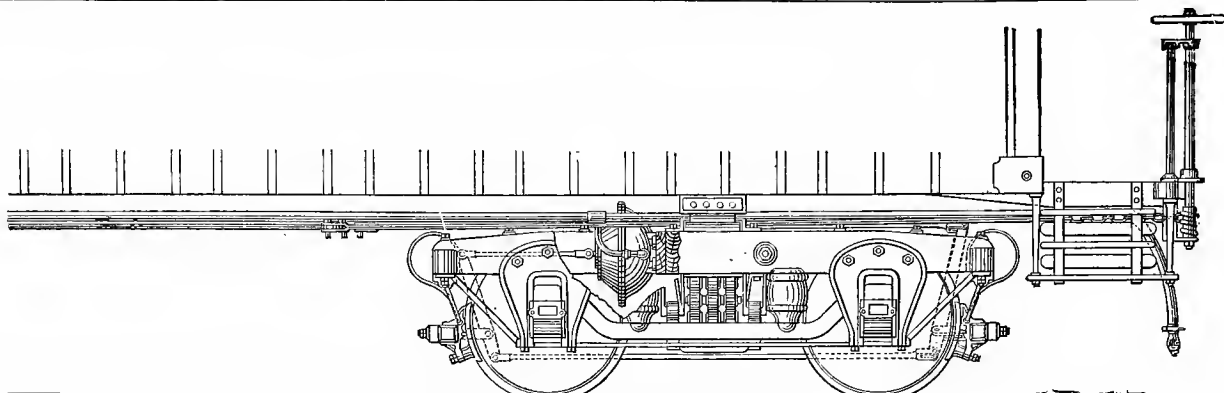

Fig. 1661. Part Sectional Side Elevation.

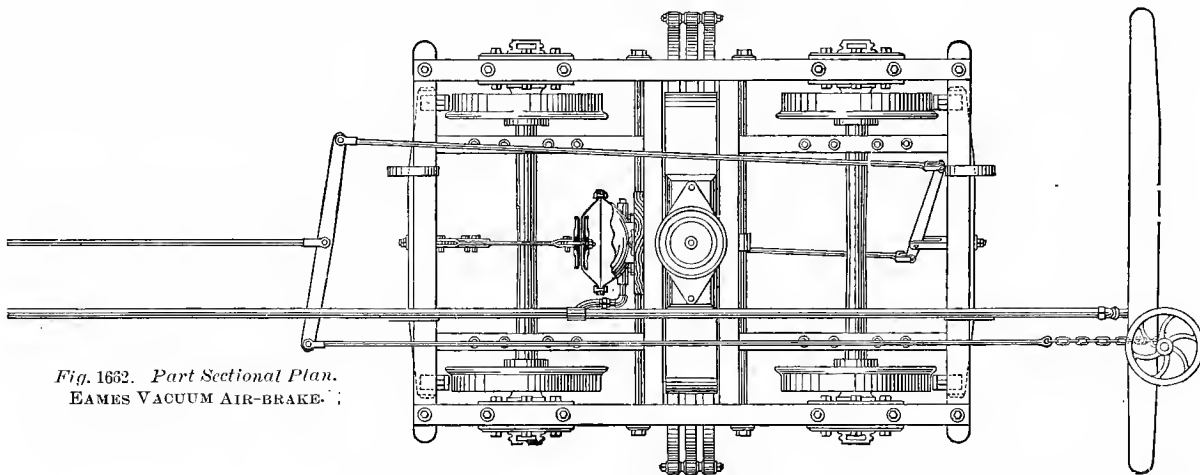

Fig. 1662. Part Sectional Plan.
EAMES VACUUM AIR-BRAKE.

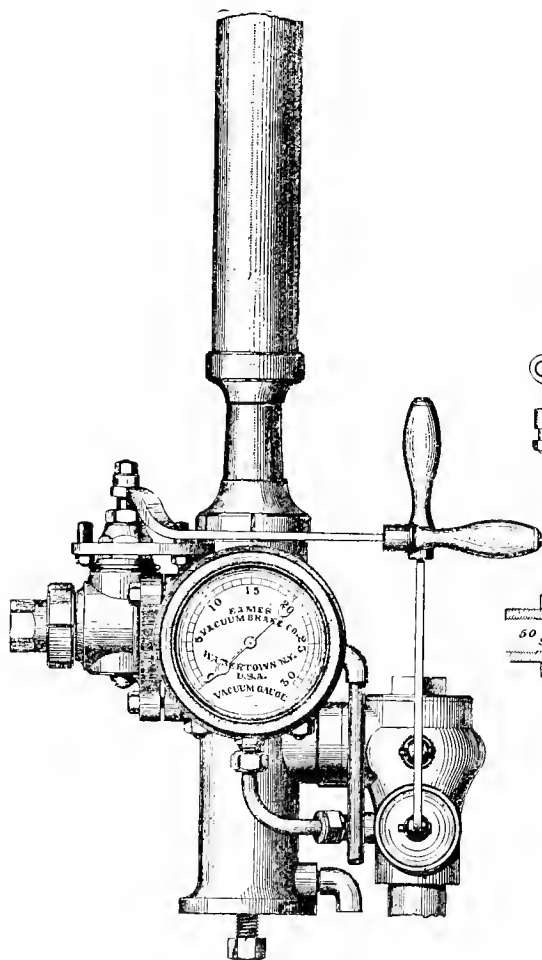

Fig. 1663. Elevation.

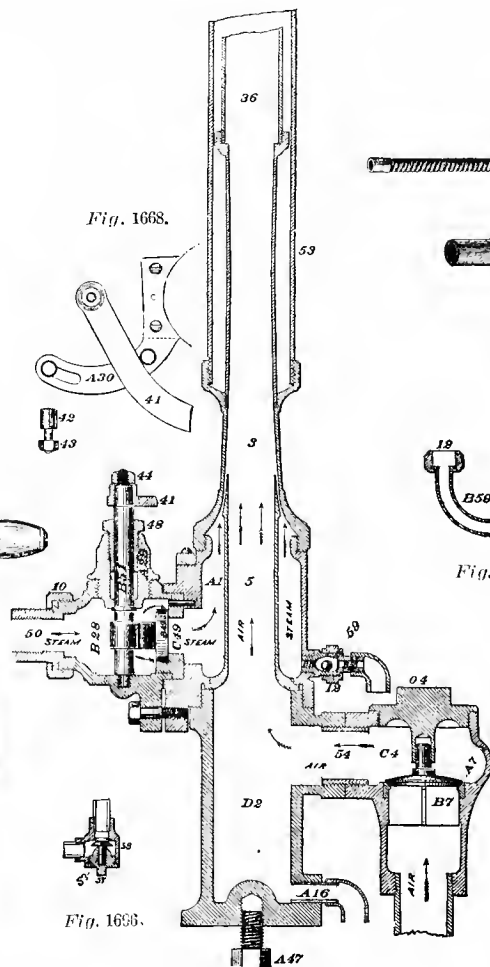

Fig. 1664. Section.

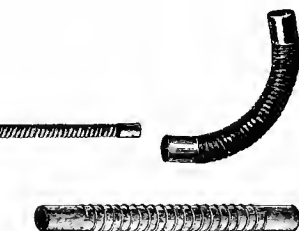

Fig. 1665a b c.
Air-brake Hose.

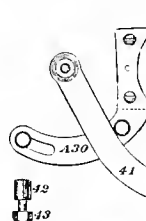

Fig. 1666.

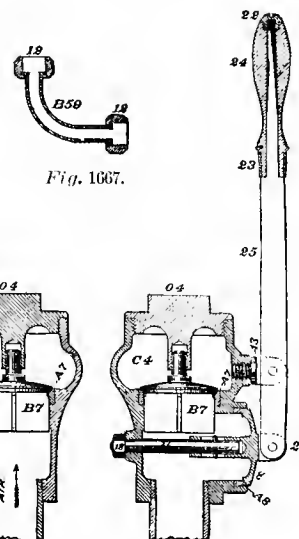

Fig. 1667.

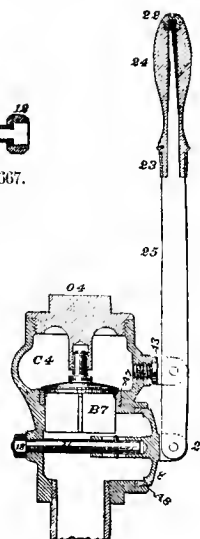
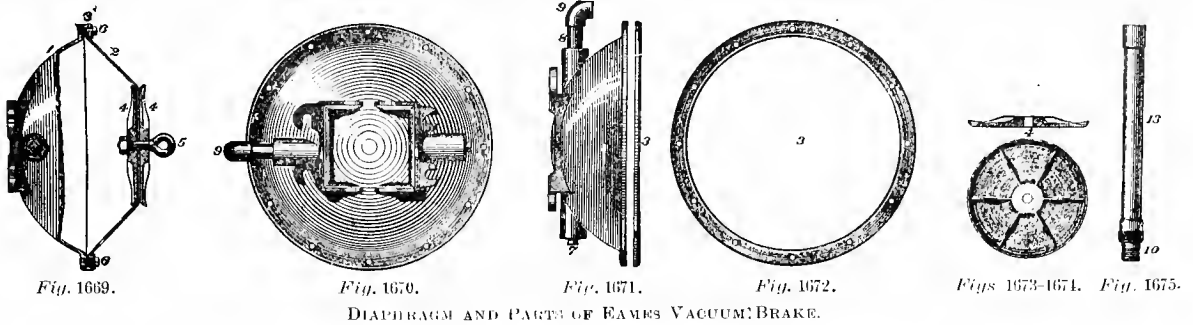

Fig. 1665.



DIAPHRAGM AND PARTS OF EAMES VACUUM BRAKE.

NAMES OF PARTS OF DIAPHRAGM AND BRAKE-HOSE.

Figs. 1669-1675 and 1676-1680.

- | | |
|--|------------------------------------|
| 1. Diaphragm-shell | } Constituting Diaphragm Complete. |
| 2. Diaphragm-rubber | |
| 3. Diaphragm-ring | |
| 4. Diaphragm-washers | |
| 5. Diaphragm Eye-bolt | |
| 6. Diaphragm Cap Screws | |
| 7. Diaphragm Plug | |
| 8. Double-thread Nipple (1½ × 3½ in.). | |
| 9. Elbow (1½ in.). | |
| 10. Hose-nipple (1½ × 3½ in.). | |
| 11. Tie (1½ × 1½ in.). | |
| 12. Hose-clip, Plain (1½ in.). | |
| 13. Diaphragm-hose (1½ × 19 in.). | |

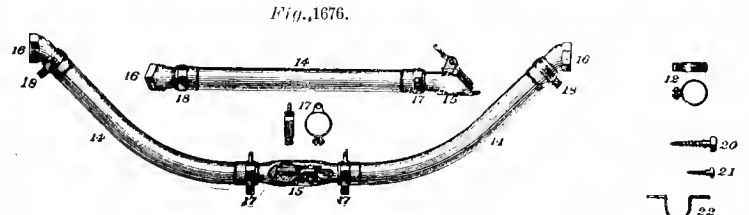

Figs. 1677-1679. EAMES VACUUM BRAKE HOSE.

- | | |
|--|----------------------------------|
| 14. Coupling-hose (1½ × 23 in.). (Details, Figs. 1684-1687.) | 18. Hose-clip, Plain (1½ in.). |
| 15. Coupling (1½ in.). | 20. Couch-screw (3½ × 9-16 in.). |
| 16. Goose-neck. | 21. Couch-screw (2 × ¾ in.). |
| 17. Hose-clip, Egg (1½ in.). | 22. Pipe-clip (1½ in.). |

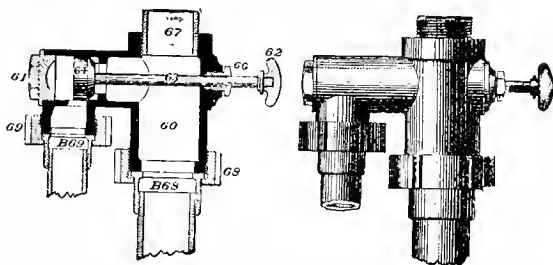
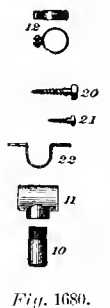

Fig. 1682. Section.

Fig. 1683. Elevation.

EAMES DIVIDING ATTACHMENT FOR ENGINES FITTED WITH DRUM BRAKES.

NAMES OF PARTS OF DIVIDING ATTACHMENT. Figs. 1682-18:3.

- | | | |
|-----------------|-----------------|---------------------------|
| 60. Body. | 64. Valve. | 68. Union-nut (1½ in.). |
| 61. Cap. | 65. Valve-seat. | B68. Union-part (1½ in.). |
| 62. Valve-knob. | 66. Gland. | 69. Union-nut (1 in.). |
| 63. Valve-stem. | 67. Nipple. | B69. Union-part (1 in.). |

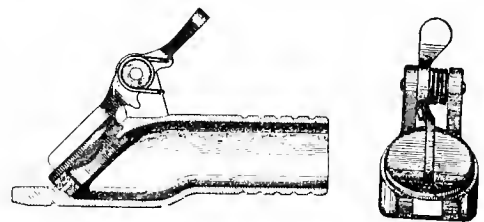

Fig. 1681. Longitudinal Section.

Fig. 1685. End Elevation.

NAMES OF PARTS OF COUPLING. Figs. 1684-1687.

- | | |
|--------------------------|---------------------|
| 1. Coupling-valve. | 4. Coupling-ears. |
| 2. Coupling-valve Lever. | 5. Coupling-gasket. |
| 3. Coupling-point. | 6. Coupling-spring. |

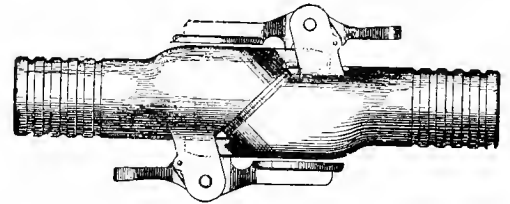

Fig. 1686. Side Elevation.

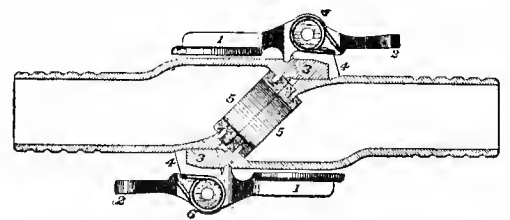

Fig. 1687. Longitudinal Section, EAMES VACUUM HOSE COUPLING.

NAMES OF PARTS OF EJECTOR. Figs. 1663-1668.

- | | | | |
|---------------------------|----------------------------|--------------------------|------------------------|
| A1. Steam-body. | 12. Union-nut. | A29. Steam-valve Nut. | C49. Steam-valve Seat. |
| D2. Air-body. | 13. Release-lever Fulcrum. | A30. Lever-quadrant. | 50. Ball Joint. |
| 3. Upper Body. | B16. Ball Drip-valve Body. | 36. Top Tube. | B51. Steam-valve Stem. |
| C4. Release-valve Body. | 17. Release-valve Stud. | 41. Steam-valve Lever. | 53. Exhaust-pipe. |
| 5. Main Air-tube. | 18. Release-valve Nut. | 42. Lever-quadrant Stud. | 54. Nipple. |
| 6. Upper Air-tube. | 20. Fulcrum-pin. | 43. Lever-quadrant Nut. | B55. Union-part |
| A7. Air Check-valve Seat. | 22. Handle Nut. | 44. Valve-stem Nut. | 56. Drip-valve Body. |
| B7. Air Check-valve. | 23. Handle Ferrule. | A47. Base-cap Screw. | 57. Drip-valve Cap. |
| 8. Release-valve. | 24. Handle. | 48. Steam-valve Gland. | 58. Drip-valve. |
| A8. Release-valve Seat. | 25. Release-lever. | B49. Steam-valve. | 59. Drip-valve Ball. |
| 10. Steam Spanner-nut. | B28. Steam-valve Body. | | |

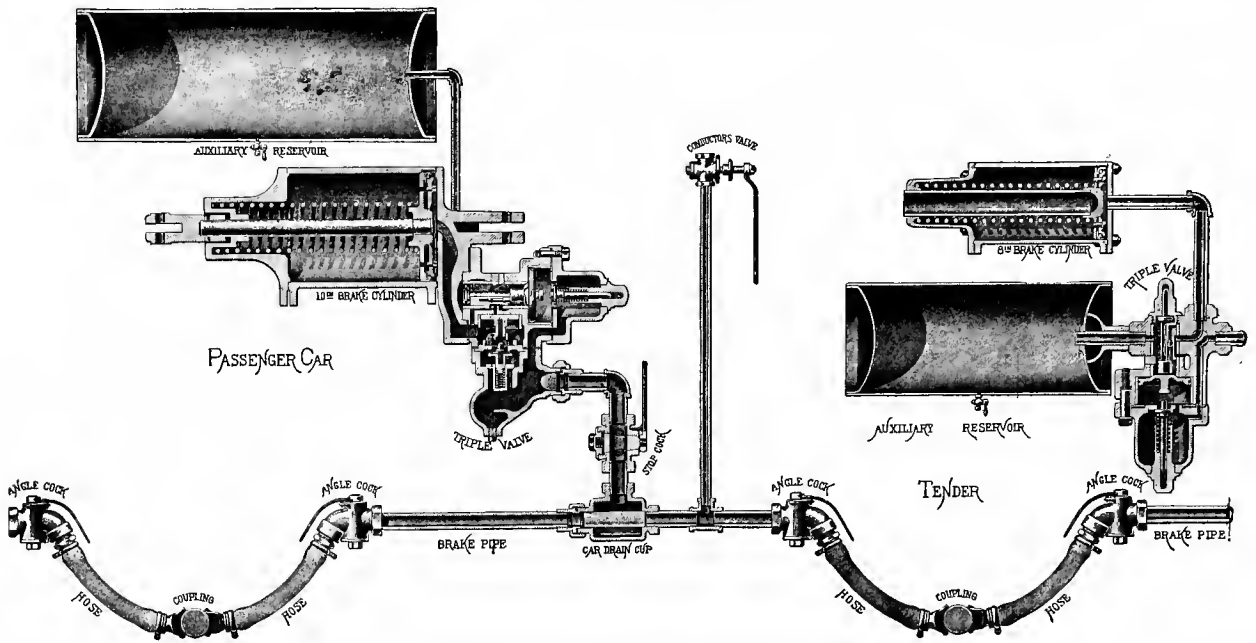

Fig. 1688. Sectional View, showing general arrangement of apparatus.

WESTINGHOUSE QUICK-ACTION AUTOMATIC AIR-BRAKE.

NAMES OF PARTS OF PUMP.

Fig. 1689.

- 2. Top-head (complete).
- 3. Steam Cylinder (complete).
- 4. Center-piece (complete).
- 5. Air-cylinder (complete).
- 6. Air-cylinder Head.
- 7. Main-valve (complete).
- 8. Upper Main-valve Packing-ring.
- 9. Lower Main-valve Packing-ring.
- 10. Steam-piston and Rod.
- 11. Air-piston (complete).
- 12. Steam-piston Packing-ring.
- 13. Air-piston Packing-ring.
- 14. Steam-pipe Union-nut ($\frac{3}{4}$ -in.).
- 15. Exhaust-pipe Union-nut (1-in.).
- 16. Reversing-valve.
- 17. Reversing-valve Stem.
- 18. Reversing-valve Plate.
- 19. Reversing-valve Bush.
- 20. Reversing-valve Chamber-cap.
- 21. Reversing-cylinder Cap.
- 22. Reversing-cylinder.
- 23. Reversing-piston (complete).
- 24. Reversing-piston Packing-ring.

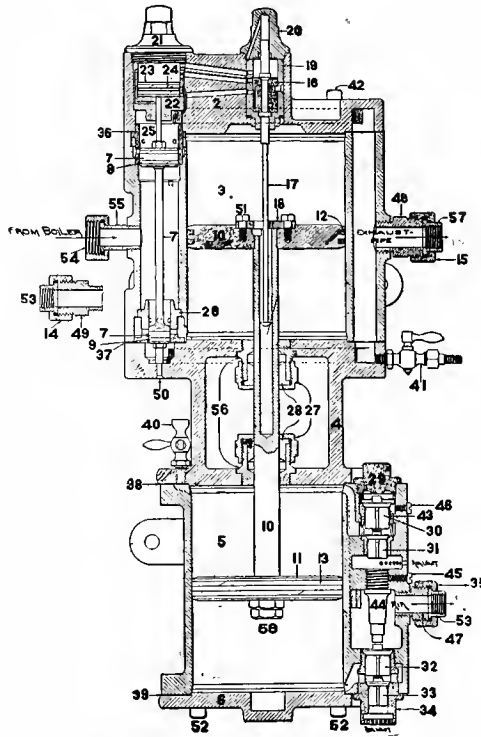

Fig. 1689. Longitudinal Section,

EIGHT-INCH AIR PUMP.

WESTINGHOUSE AIR BRAKE COMPANY

- 25. Upper Main-valve Bush.
- 26. Lower Main-valve Bush.
- 27. Packing-nut.
- 28. Packing-gland.
- 29. Upper Valve-chamber Cap.
- 30. Upper Discharge-valve.
- 31. Upper Receiving-valve.
- 32. Lower Discharge-valve.
- 33. Lower Receiving-valve.
- 34. Lower-valve Chamber-cap.
- 35. Reservoir Union-nut ($\frac{3}{4}$ in.).
- 36. Upper Steam-cylinder Gasket.

- 37. Lower Steam-cylinder Gasket.
- 38. Upper Air-cylinder Gasket.
- 39. Lower Air-cylinder Gasket.
- 40. Air-cylinder Oil-cup.
- 41. Drain-cock.
- 42. Cylinder-head Bolt ($\frac{1}{2} \times 2\frac{1}{4}$).
- 43. Valve-chamber Bush.
- 44. Discharge-valve Stop.
- 45. Valve-stop Set-screw.
- 46. Chamber-bush Set-screw.
- 47. Reservoir Union-stud ($\frac{3}{4}$ -in.).
- 48. Exhaust-pipe Union-stud (1-in.).
- 49. Steam-pipe Union-stud ($\frac{3}{4}$ -in.).
- 50. Main-valve Stop.
- 51. Reversing-valve Plate-bolt.
- 52. Pump-head Bolt ($\frac{1}{2} \times 1\frac{1}{4}$ in.).
- 53. Union-swivel.
- 54. Governor Union-nut.
- 55. Governor Union-stud.
- 56. Piston Stuffing-box.
- 57. Union-swivel.
- 58. Piston-rod Nut.

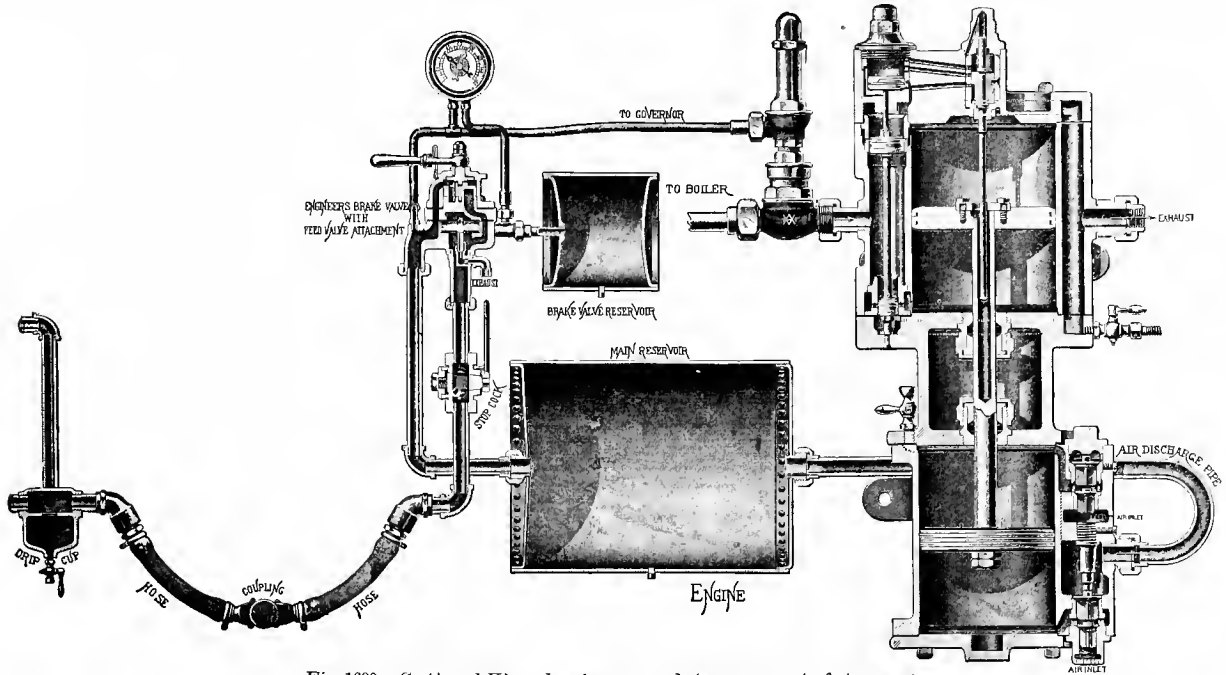

Fig. 1690. Sectional View showing general Arrangement of Apparatus, WESTINGHOUSE QUICK-ACTION AUTOMATIC AIR-BRAKE.

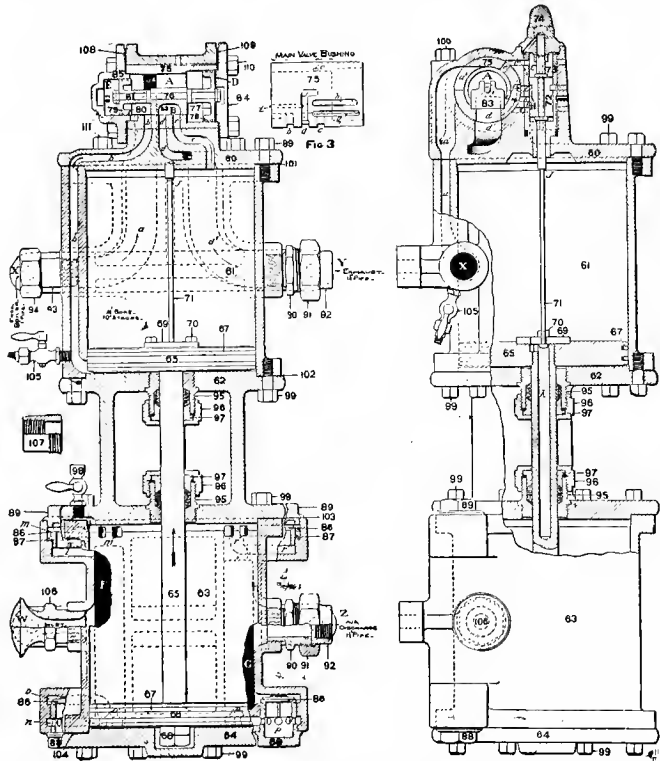

Fig. 1691. Longitudinal Section.

Fig. 1692. Cross Section.

NINE-AND-ONE-HALF-INCH AIR-PUMP.
WESTINGHOUSE AIR BRAKE COMPANY.

NAMES OF PARTS OF PUMPS. Figs. 1691-1692.

- | | | |
|--------------------------------|-----------------------------------|---|
| 60. Top Head (Complete). | 69. Reversing-valve Plate. | 78. Large Main-valve Piston Packing-ring. |
| 61. Steam Cylinder (Complete). | 70. Reversing-valve Plate Bolt. | 79. Small Main-valve Piston-head. |
| 62. Center-piece (Complete). | 71. Reversing-valve Rod. | 80. Small Main-valve Piston Packing-ring. |
| 63. Air-cylinder (Complete). | 72. Reversing-valve. | 81. Main Valve-stem. |
| 64. Lower Head. | 73. Reversing-valve Chamber-bush. | 82. Main Valve-stem Nut. |
| 65. Steam-piston and Rod. | 74. Reversing-valve Chamber-cap. | 83. Main Slide-valve. |
| 66. Air-piston (Complete). | 75. Main-valve Bush. | 84. Right Main-valve Cylinder-head |
| 67. Piston Packing-ring. | 76. Main Piston valve (Complete). | 85. Left Main-valve Cylinder-head. |
| 68. Piston-rod Nut. | 77. Large Main-valve Piston-head. | 86. Air-valve. |
| | | 87. Air-valve Seat. |
| | | 88. Air-valve Cage. |
| | | 89. Valve-chamber Cap. |
| | | 90. Union-stud (1 1/4 in.). |
| | | 91. Union-nut (1 1/4 in.). |
| | | 92. Union-swivel (1 1/4 in.). |
| | | 93. Steam-pipe Stud (1 in.). |
| | | 94. Governor Union-nut. |
| | | 95. Stuffing-box. |
| | | 96. Stuffing-box Nut. |
| | | 97. Stuffing-box Gland. |
| | | 98. Air-cylinder Oil-cup. |
| | | 99. Short Cap-screw (5/8 x 1 3/4). |
| | | 100. Long Cap-screw (5/8 x 6 1/4). |
| | | 101. Upper Steam-cylinder Gasket. |
| | | 102. Lower Steam-cylinder Gasket. |
| | | 103. Upper Air-cylinder Gasket. |
| | | 104. Lower Air-cylinder Gasket. |
| | | 105. Drain-cock. |
| | | 106. Air-strainer. |
| | | 107. Steam-pipe Sleeve (1 in.) |
| | | 108. Left Main-valve Head-gasket. |
| | | 109. Right Main-valve Head-gasket. |
| | | 110. Main-valve Head-bolt. |
| | | 111. Cap-screw. |

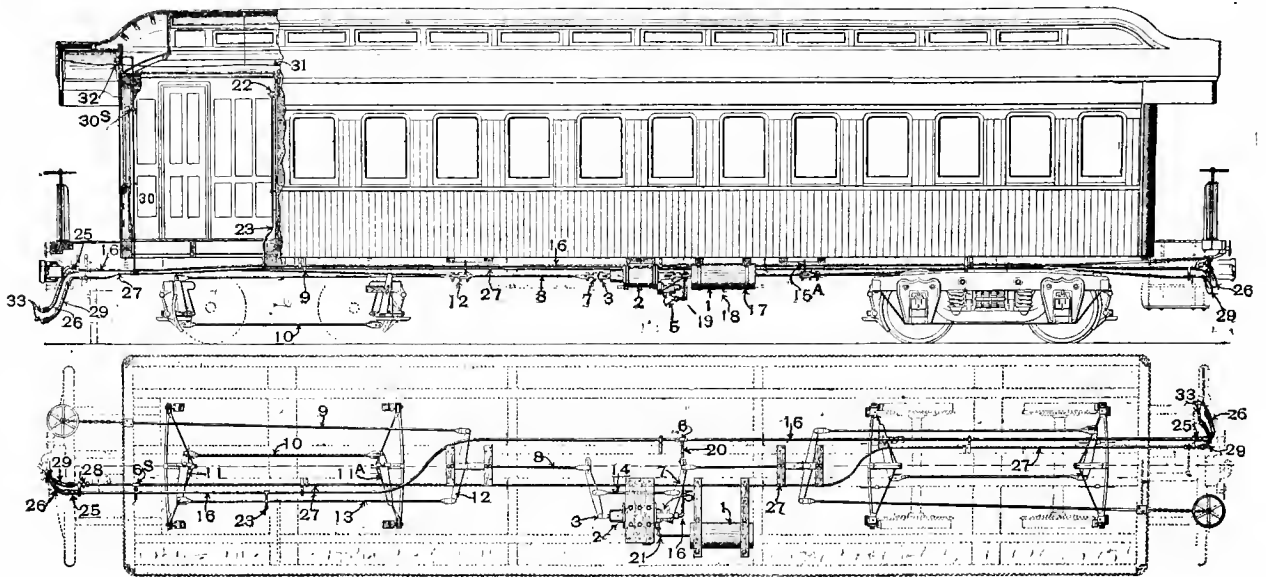

Figs. 1693-1694. Sectional Side Elevation and Plan of a Passenger Car.
APPLICATION OF WESTINGHOUSE AIR-BRAKE TO A PASSENGER CAR.

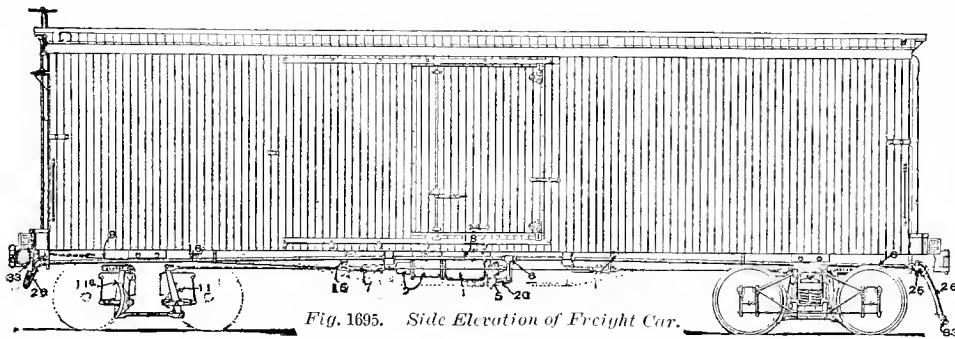

Fig. 1695. Side Elevation of Freight Car.

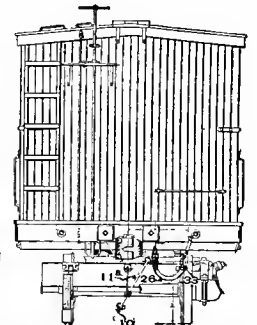

Fig 1695. End Elevation.

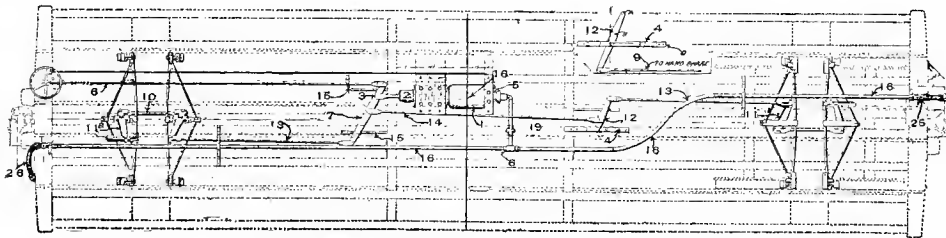

Fig. 1697. Sectional Plan of Freight Car.

APPLICATION OF WESTINGHOUSE AIR-BRAKE TO A FREIGHT CAR.

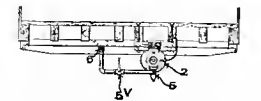

Fig 1698. Cross Section of Underframe.

NAMES OF PARTS OF PASSENGER AND FREIGHT BRAKE-GEAR. Figs. 1693-1698.

- | | | | |
|---|---------------------------------------|--|--|
| 1. Auxiliary-reservoir. | 10. Lower-brake Connecting-rod. | 18. Auxiliary reservoir Bleeding-cock. | 27. Train Signal-pipe. |
| 2. Brake-cylinder. | 11. Live Truck-lever. | 19. Brake Cut-out Cock. | 28. Train-signal Stop-cock. |
| 3. Piston-rod Cross-head. | 11a. Dead Truck-lever. | 20. Branch-pipe from Train-pipe to Triple-valve. | 29. Signal-hose. |
| 4. Floating-lever Bracket. | 12. Hodge or Floating-lever. | 21. Pipe from Triple valve to Auxiliary-reservoir. | 30. Signal Branch-pipe to Car Discharge-valve. |
| 5. Triple-valve. | 13. Upper Brake-lever Connecting-rod. | 22. Conductor's-valve. | 30s. Signal Branch-pipe Cut-out Cock. |
| 6. Air-strainer. | 14. Cylinder-lever Tie-rod. | 23. Branch-pipe to Conductor's-valve. | 31. Signal-cord. |
| 7. Cylinder-lever. | 15a. Hodge-lever Guide. | 25. Angle-cock. | 32. Signal Car-discharge-valve. |
| 8. Cylinder-lever and Hodge-lever Connecting-rod. | 15w. Cylinder-lever Guide. | 26. Air-brake Hose. | 33. Brake Hose-coupling. |
| 9. Hand-brake Connecting-rod. | 16. Train Brake-pipe. | | 34. Signal Hose-coupling. |
| | 17. Auxiliary-reservoir Band. | | |

NAMES OF PARTS OF BRAKE GEAR OF LOCOMOTIVE AND TENDER. Figs. 1699-1707.

- | | | | |
|---|--|---|----------------------------------|
| 1. Main-reservoir. | 9. Pipe from Main-reservoir and to Engineer's Brake-valve. | 16. Triple-valve. | 23. Signal-whistle. |
| 2. Brake-cylinder. | 10. Engineer's Brake-valve. | 17. Branch-pipe from Train-pipe to Triple-valve. | 23w. Pipe to Signal whistle. |
| 3. Pump Steam-cylinder. | 10e. Equalizing-reservoir. | 18. Tender Auxiliary-reservoir. | 24. Air-signal Reducing-valve. |
| 3g. Pump-governor. | 11. Air-brake Hose-coupling. | 19. Pipe from Auxiliary-reservoir Brake-cylinder. | 26. Signal-valve. |
| 4. Pump Air-cylinder. | 12. Driver-brake Cylinder. | 20. Air-gage. | 27. Signal-pipe. |
| 5. Air-strainer. | 13. Steam Throttle-valve. | 21. Driver-brake Tie-rods. | 28. Signal Hose-coupling. |
| 6. Steam-pipe. | 14. Train Brake-pipe. | | 29. Train Signal-pipe Stop-cock. |
| 7. Exhaust-pipe. | 15. Angle-cock. | | |
| 8. Air-pipe. | | | |
| 9a. Air-signal Supply-pipe from Main-reservoir. | | | |

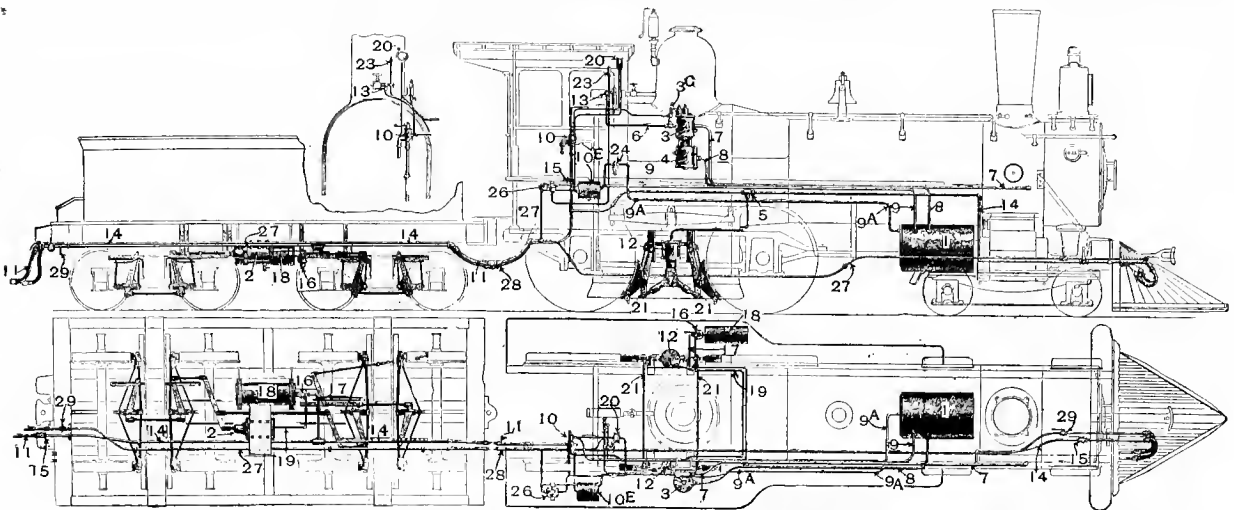

Figs. 1699-1700. Sectional Side Elevation and Plan of Locomotive, showing application of Westinghouse Air Brake.

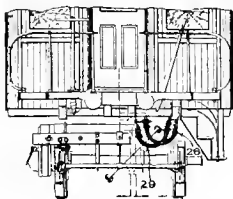
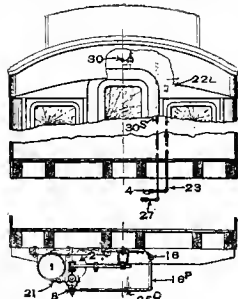

Fig. 1701. Part End Elevation.



Figs. 1702-1704. Part End Elevation and Cross Sections.

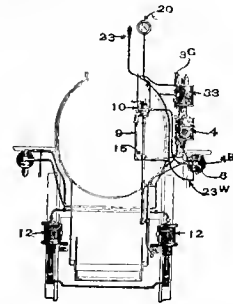

Fig. 1705. Sectional End Elevation of Locomotive.

APPLICATION OF WESTINGHOUSE AIR-BRAKE TO A LOCOMOTIVE, TENDER, AND PASSENGER CAR.

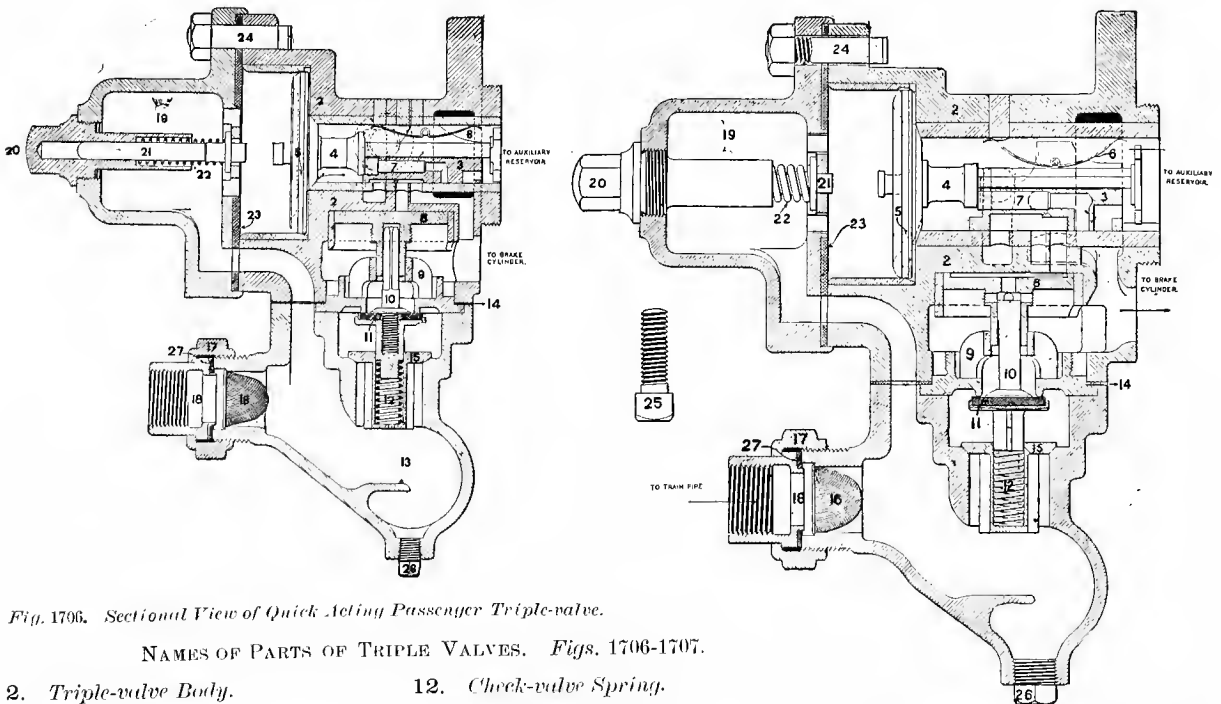

Fig. 1706. Sectional View of Quick Acting Passenger Triple-valve.

Fig. 1707. Sectional View of Special Quick Acting Passenger Triple-valve.

NAMES OF PARTS OF TRIPLE VALVES. Figs. 1706-1707.

- | | | |
|----------------------------|------------------------------|--------------------------|
| 2. Triple-valve Body. | 12. Check-valve Spring. | 22. Graduating Spring. |
| 3. Slide-valve. | 13. Check-valve Case. | 23. Leather Gasket. |
| 4. Piston. | 14. Check-valve Case Gasket. | 24. Bolt and Nut. |
| 5. Piston Packing-ring. | 15. Check-valve. | 25. Half-inch Cap-Screw. |
| 6. Slide-valve Spring. | 16. Strainer. | 26. One-half-inch Plug. |
| 7. Graduating-valve. | 17. Union-nut. | 27. Union Gasket. |
| 8. Emergency-valve Piston. | 18. Union-swivel. | |
| 9. Emergency-valve Seal. | 19. Drain-cup. | |
| 10. Emergency-valve. | 20. Graduating-stem Nut. | |
| 11. Rubber Seat. | 21. Graduating Stem. | |

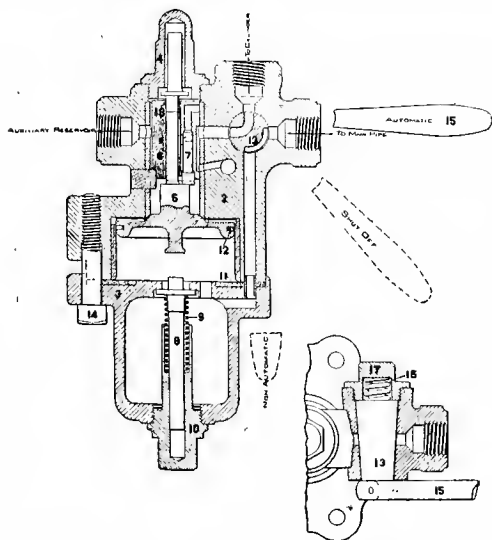

Fig. 1708. Fig. 1709.

TRIPLE VALVE FOR LOCOMOTIVES AND TENDERS.

Fig. 1710.

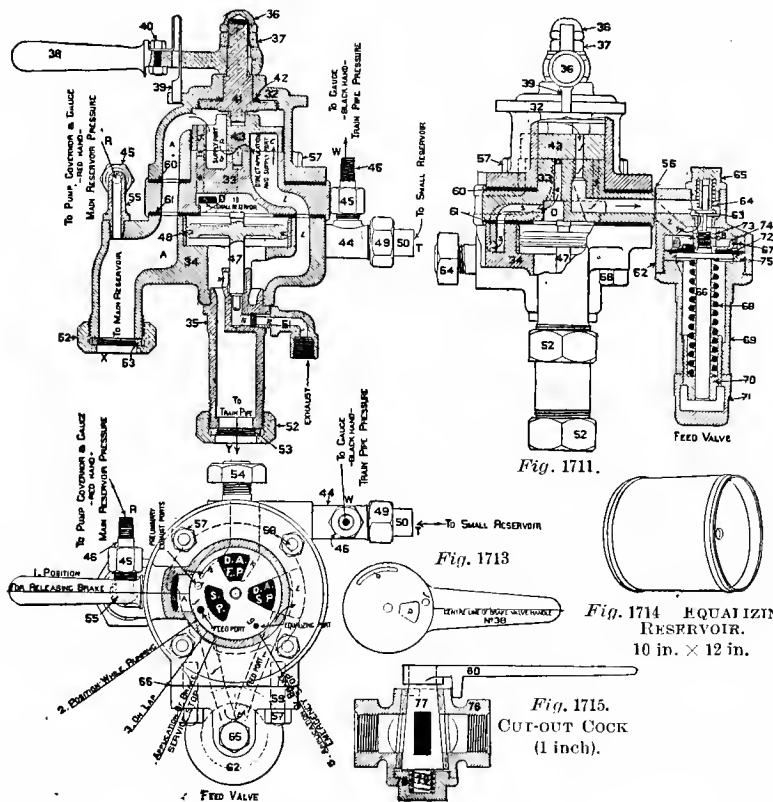

Fig. 1712.

WESTINGHOUSE IMPROVED ENGINEER'S BRAKE AND EQUALIZING DISCHARGE-VALVE, WITH FEED-VALVE ATTACHMENT.

NAMES OF PARTS OF ENGINEER'S VALVE. Figs. 1710-1715.

- | | |
|--------------------------|-----------------------------|
| 32. Valve-body. | 45. 1/4-in. Union-nut. |
| 33. Rotary-valve Seat. | 46. 1/2-in. Union-swivel. |
| 34. Bottom Case. | 47. Piston-valve. |
| 35. Bottom Cap. | 48. Piston-ring. |
| 36. Jam-nut. | 49. 3/8-in. Union-nut. |
| 37. Top-nut. | 50. 3/4-in. Union-swivel. |
| 38. Handle. | 51. Exhaust-pipe Fitting. |
| 39. Handle Spring. | 52. 1-in. Union-nut. |
| 40. Handle Bolt and Nut. | 53. 1-in. Union-swivel. |
| 41. Rotary-valve Key. | 54. Holding-nut. |
| 42. Washer. | 55. Gage-pipe Fitting. |
| 43. Rotary-valve. | 56. Feed-valve-case Gasket. |
| 44. Gage-pipe Tee. | 57. Half-inch Nut. |

Continued.)

NAMES OF PARTS OF TRIPLE VALVE. Figs. 1708-1709.

- | | |
|----------------------------|--------------------------|
| 2. Triple-valve Case. | 11. Leather Gasket. |
| 3. Lower Cap. | 12. Piston-packing Ring. |
| 4. Upper Cap. | 13. Four-way Cock Key. |
| 5. Piston | 14. Bolt. |
| 6. Slide-valve. | 15. Handle. |
| 7. Graduating-valve. | 16. Key-spring. |
| 8. Graduating-stem. | 17. Key-cap. |
| 9. Graduating-stem Spring. | 18. Slide-valve Spring. |
| 10. Bottom Nut. | |

NAMES OF PARTS OF ENGINEER'S VALVE.

Figs. 1710-1715.

(Continued.)

- | |
|-----------------------------|
| 58. Half-inch Bolt. |
| 59. Feed-valve Stud. |
| 60. Upper-gasket. |
| 61. Lower-gasket. |
| 62. Feed-valve Body. |
| 63. Supply-valve. |
| 64. Feed-valve Spring. |
| 65. Feed-valve Cap-nut. |
| 66. Feed-valve Piston-rod. |
| 67. Friction-ring. |
| 68. Piston-spring. |
| 69. Spring-box. |
| 70. Adjusting-nut. |
| 71. Check-nut. |
| 72. Diaphragm. |
| 73. Feed-valve Piston-nut. |
| 74. Feed-valve Piston-head. |
| 75. Diaphragm-ring. |
| 76. Cock-body. |
| 77. Cock-key. |
| 78. Cap-nut. |
| 79. Key-spring. |
| 80. Handle. |

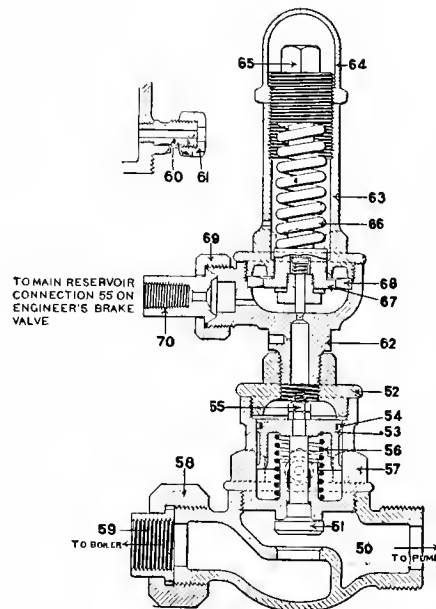

Fig. 1716. WESTINGHOUSE PUMP GOVERNOR.

Numbers refer to list on the following page

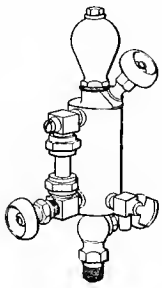

Fig. 1717.
Air Pump Lubricator.

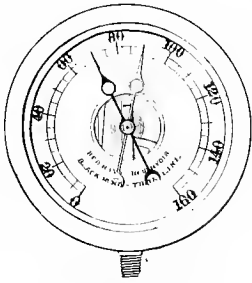

Fig. 1718.
Duplex Air Gauge.

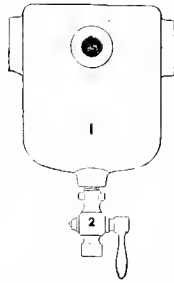

Fig. 1719.
Tender Drain Cup
and Cock.

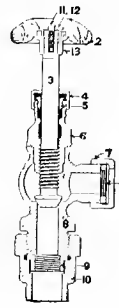

Fig. 1720.
Steam Valve.

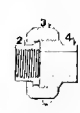

Fig. 1721.
Reservoir
Union.

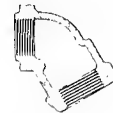

Fig. 1722.
Angle
Fitting.



Fig. 1723.
Triple
Valve
Bracket.



Fig. 1724.
Triple
Valve
Nipple.



Fig. 1725.
Cam-nut Wrench.

DETAILS OF WESTINGHOUSE AIR-BRAKE APPARATUS.

NAMES OF PARTS OF FREIGHT CYLINDERS. Figs. 1728-1729.

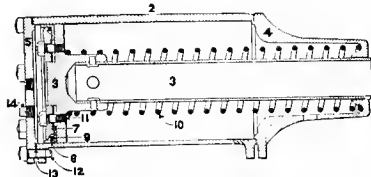

Fig. 1726. TENDER BRAKE-CYLINDER.

- | | |
|----------------------------|---------------------------------|
| 2. Cylinder-body. | 9. Release-spring. |
| 3. Piston-head and Rod. | 10. Reservoir. |
| 4. Back Cylinder-head. | 11. Drain-plug. |
| 5. Follower-stud and Nut. | 12. Reservoir-stud and Nut. |
| 6. Follower. | 13. Cylinder-head Bolt and Nut. |
| 7. Piston Packing-leather. | 14. Cylinder-gasket. |
| 8. Packing expander. | 15. Triple-valve Gasket. |

NAMES OF PARTS OF STEAM VALVE. Fig. 1720.

NAMES OF PARTS. Fig. 1726.

2. Cylinder-body.
3. Piston-head and Rod.
4. Back Head.
5. Front Head.
7. Follower.
8. Packing Leather.
9. Packing-expander.
10. Release-spring.
11. Follower Stud and Nut.
12. Cylinder-head Bolt and Nut.
13. Gasket.
14. Oiling Plug.

- | | | |
|-------------------|------------------|-----------------------------|
| 2. Hand-wheel. | 7. Union-nut. | 11. Hand-wheel Screw. |
| 3. Valve-stem. | 8. Valve-body. | 12. Hand-wheel Washer. |
| 4. Packing-nut. | 9. Union-swivel. | 13. Hand-wheel Socket. |
| 5. Packing-gland. | 10. Valve-stud. | 14. Steam-pipe Swivel-ring. |
| 6. Neck-piece. | | |

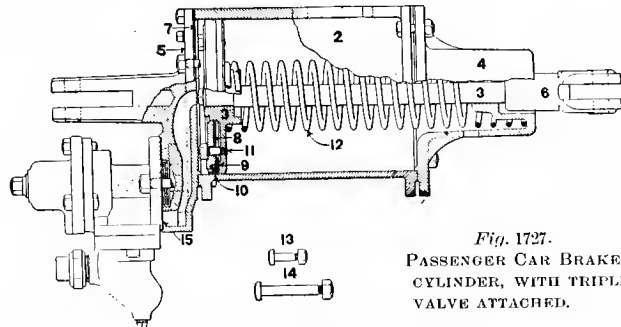

Fig. 1727.
PASSENGER CAR BRAKE-CYLINDER,
WITH TRIPLE
VALVE ATTACHED.

NAMES OF PARTS OF GOVERNOR.

Figs. 1716.

25. Steam-valve Body.
26. Steam Valve.
27. Cylinder-cap.
28. Governor Piston.
29. Piston Packing-ring.
30. Governor Piston-nut.
31. Governor Piston-spring.
32. Steam-valve Cylinder.
33. One-inch Union-nut.
34. One-inch Union-swivel.
35. Waste-pipe Stud.
36. Waste-pipe Union-nut.
37. Diaphragm-body.
38. Spring-box.
39. Cup-nut.
40. Regulating-nut.
41. Regulating-spring.
42. Diaphragm (complete).
43. Diaphragm-ring.
44. Union-nut.
45. Union-swivel.

NAMES OF PARTS. Fig. 1727.

- | | | |
|-------------------------|-----------------------|---------------------------------|
| 2. Cylinder-body. | 6. Cross-head. | 11. Follower Stud and Nut. |
| 3. Piston-head and Rod. | 7. Gasket. | 12. Release-spring. |
| 4. Back Head. | 8. Follower. | 13. Cylinder-head Bolt and Nut. |
| 5. Front Head. | 9. Packing Leather. | 14. Triple-valve Bolt and Nut. |
| | 10. Packing Expander. | 15. Triple-valve Gasket. |

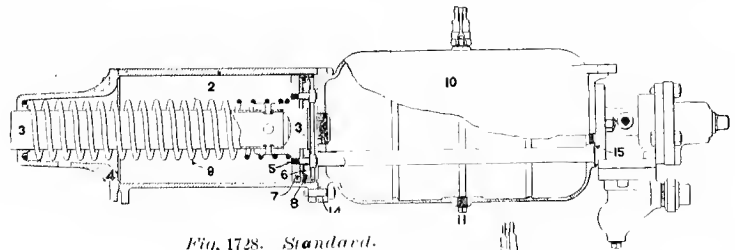

Fig. 1728. Standard.

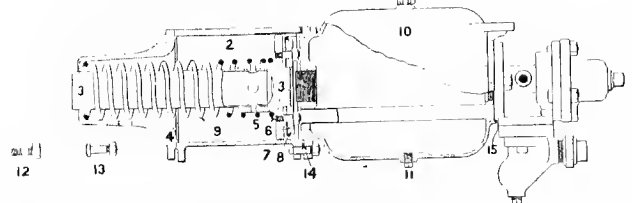

Fig. 1729. Special.

FREIGHT BRAKE-CYLINDERS, RESERVOIRS AND TRIPLE VALVES.

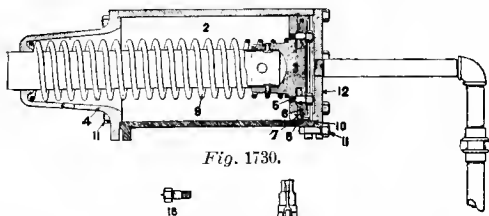

Fig. 1730.

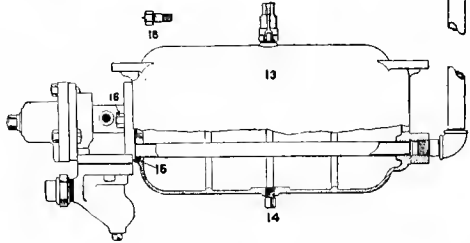

Fig. 1731. Sectional Side Elevation.

NAMES OF PARTS OF FREIGHT BRAKE CYLINDER.

Figs. 1730-1731.

- | | |
|---|----------------------------------|
| 2. Cylinder Body. | 9. Release-spring. |
| 3. Piston-head and Rod, Follower-studs and Nut. | 10. Gasket. |
| 4. Back-head. | 11. Cylinder-head Bolt and Nut. |
| 5. Follower-stud and Nut. | 12. Front-head. |
| 6. Follower. | 13. Special Auxiliary Reservoir. |
| 7. Piston-packing Leather. | 14. Drain-plug. |
| 8. Packing Expander. | 15. Triple-valve Gasket. |
| | 16. Reservoir-stud and Nut. |

STANDARD SPECIAL FREIGHT BRAKE-CYLINDER, WITH DETACHED AUXILIARY RESERVOIR AND TRIPLE VALVE.

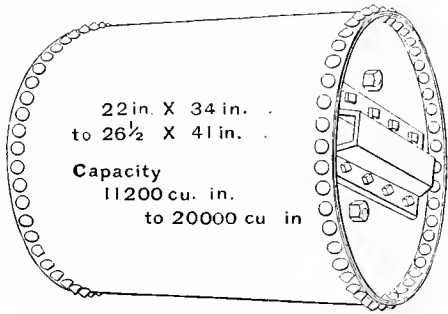

Fig. 1732.

Main Reservoir for Locomotive.

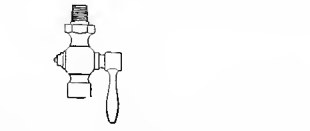

Fig. 1733. Reservoir Drain Cock.

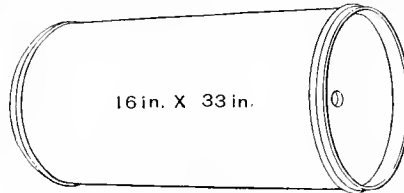

Fig. 1734.

Auxiliary Reservoir for 14-in. Cylinder.

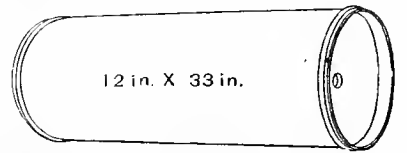

Fig. 1735.

Auxiliary Reservoir for 10-in. Cylinder.

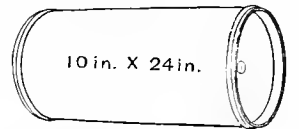

Fig. 1736.

Auxiliary Reservoir for Locomotive Driver Brake and Tenders

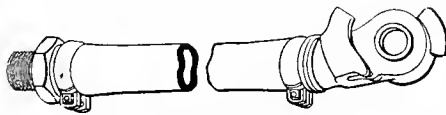

Fig. 1737.

Hose and Coupling, Passenger.

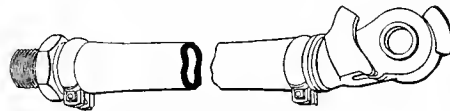

Fig. 1738.

Hose and Coupling, Freight.

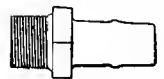

Fig. 1739.

Hose Nipple.

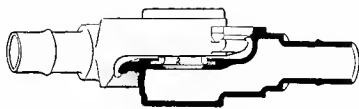

Fig. 1740.

Hose Coupling, Passenger.

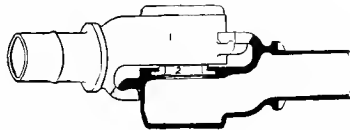

Fig. 1741.

Hose Coupling, Freight.

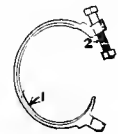

Fig. 1742.

Hose Clamp.

Fig. 1744. Cut-out Cock.

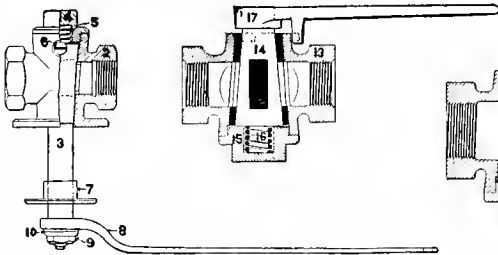

Fig. 1743.

Conductor's Valve.

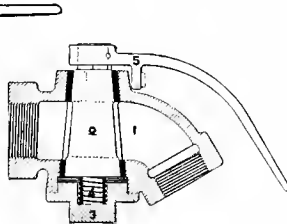

Fig. 1745.

Angle Cock.

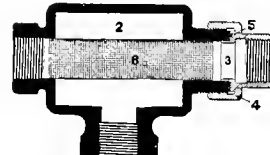

Fig. 1746.

Air Strainer.

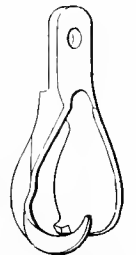

Fig. 1746a.

Coupling Hook.

NAMES OF PARTS.

Fig. 1743.

2. Valve-body.
3. Valve-key.
4. Valve-cup.
5. Key-spring.
6. Key-stop.
7. Key Escutcheon.
8. Valve-handle.
9. Key-nut.
10. Key-washer.

NAMES OF PARTS.

Fig. 1744.

13. Cock-body.
14. Cock-key.
15. Cock-cap.
16. Key-spring.
17. Handle.

NAMES OF PARTS.

Fig. 1745.

1. Angle-cock Body.
2. Angle-cock Key.
3. Angle-cock Cap.
4. Angle-cock Key-spring.
5. Angle-cock Handle.
6. 1½-in. to 1-in. Reducer.

NAMES OF PARTS.

Fig. 1746.

2. Drain-cup Body.
3. 1-in. Union-swivel.
4. Union-nut.
5. Union-gasket.
6. Strainer.

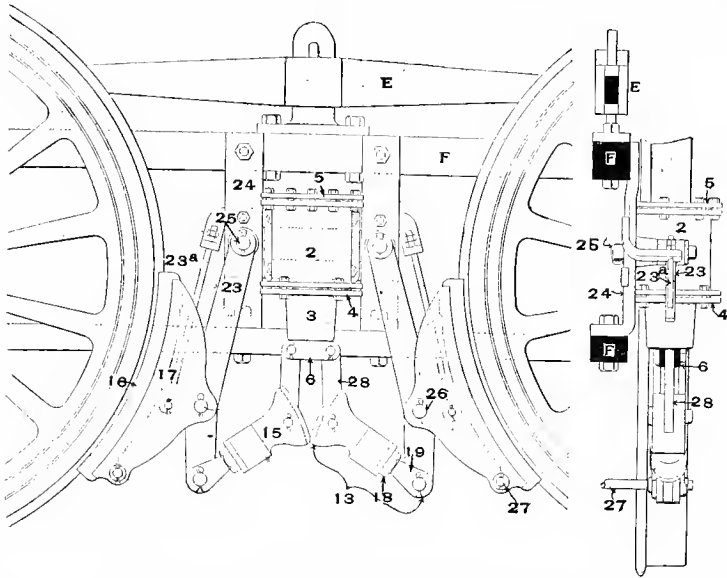

Fig. 1747.

WESTINGHOUSE CAM DRIVING-WHEEL BRAKE.

NAMES OF PARTS OF DRIVER BRAKE. Fig 1747.

- 2. Cylinder Body.
- 3. Lower Cylinder-head.
- 5. Upper Cylinder-head.
- 6. Cross-head.
- 13. Adjusting Nut.
- 15. Cam.
- 16. Brake-shoe.
- 17. Brake-shoe Holder or Brake-head.
- 18. Nut.
- 19. Cam-screw.
- 23. Brake-shoe Hanger.
- 23a. Brake-block Safety-hanger.
- 24. Brake-block Suspending Plate.
- 25. Brake-block Suspending Stud.
- 26. Brake-block Pin.
- 27. Brake-block Pin-rod.
- 28. Eccentric-lever Links

NAMES OF PARTS DRIVER-BRAKE CYLINDER.

Fig. 1748.

- 2. Cylinder-body.
- 3. Piston-head and Rod.
- 4. Lower-head.
- 5. Upper-head.
- 6. Release-spring.
- 7. Cylinder-head Bolt and Nut.
- 8. Gasket.
- 9. Cross-head.
- 10. Follower.
- 11. Piston Packing-leather.
- 12. Packing-expander.
- 13. Follower-stud and Nut.

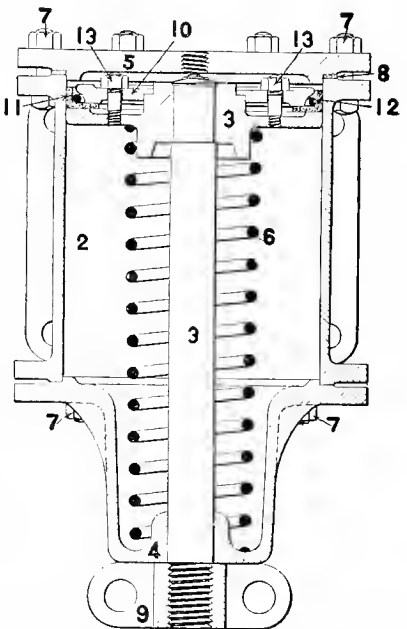

Fig. 1748. Push Down Driver-brake Cylinder.

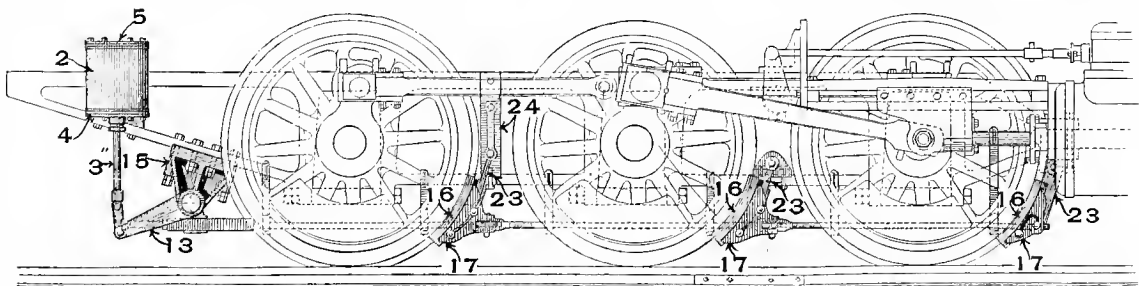

Fig. 1749.

OUTSIDE EQUALIZED PRESSURE DRIVER BRAKE.
(For three or more pairs of driving wheels.)

NAMES OF PARTS OF DRIVER BRAKE. Fig. 1749.

- 2. Driver-brake Cylinder.
- 3. Piston-rod.
- 4. Lower Cylinder-head.
- 5. Upper Cylinder-head.
- 13. Bell Crank.
- 15. Fulcrum-bracket.
- 16. Driver-brake Shoe.
- 17. Driver-brake Head or Shoe-holder
- 23. Driver-brake Hanger.
- 24. Hanger Bracket.

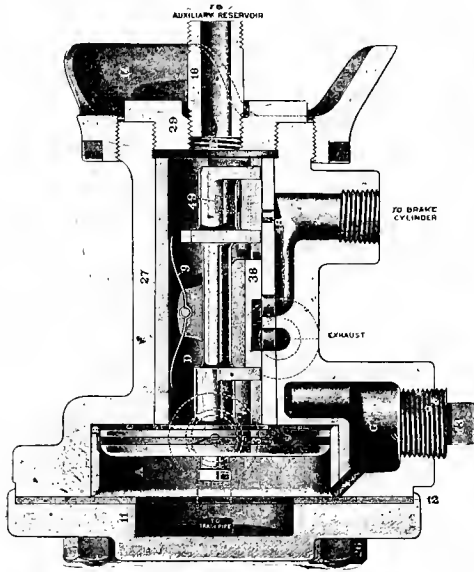

Fig. 1750. Plain Triple-valve.

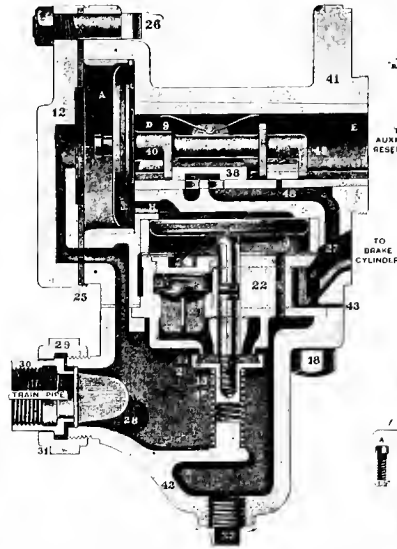

Fig. 1751. Quick-action Triple-valve.

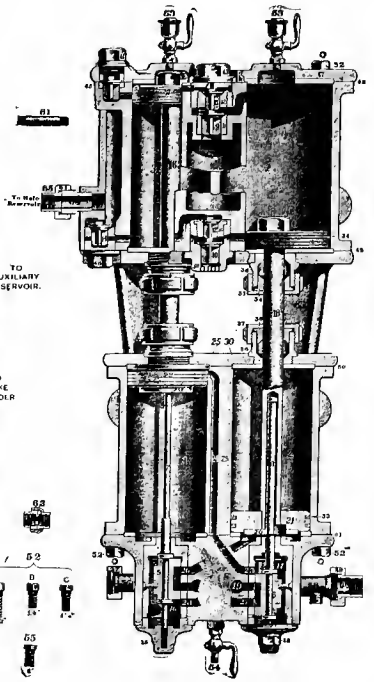

Fig. 1752. Duplex Air-pump.

AIR-BRAKE EQUIPMENT OF THE NEW YORK AIR BRAKE COMPANY.

NAMES OF PARTS OF PLAIN TRIPLE VALVE. Fig. 1750.

- 3. Piston Packing-ring.
- 9. Slide-valve Spring.
- 11. Cap.
- 12. Gasket.
- 13. Drip Plug.
- 14. Triple-valve Bracket.
- 16. Triple-valve Nipple.
- 26. Cap-bolt.
- 27. Triple-valve Body.
- 29. Plug.
- 38. Slide-valve.
- 40. Piston.
- 48. Graduating-valve.
- 49. Graduating-valve Spring.

NAMES OF PARTS OF TRIPLE VALVE. Fig. 1751.

- 3. Main and Emergency Piston Packing-rings.
- 9. Slide-valve Spring.
- 12. Cap.
- 13. Emergency-piston.
- 14, 15 and 20. Emergency-valve.
- 16. Emergency-valve Spring.
- 18. Emergency-valve Case-bolt.
- 20. Emergency-valve Gasket.
- 21. Check-valve.
- 22. Check-valve Cage.
- 23. Check-valve Spring.
- 24. Check-valve Plug.

- 25. Cap-gasket.
- 26. Cap-bolt.
- 27. Check-valve Cage-gasket.
- 28. Strainer.
- 29. Union-nut.
- 30. Union-swivel.
- 31. Union-gasket.
- 32. Drain-plug.
- 38. Slide-valve.
- 40. Main-piston.
- 41. Triple-valve Body.
- 42. Emergency-valve Case.
- 43. Emergency-valve Case-gasket.
- 48. Graduating-valve.
- 49. Graduating-valve Spring.

NAMES OF PARTS OF PUMP. Fig. 1752.

- 1-2. Combined Steam Cylinders.
- 3-4. Combined Air Cylinders.
- 5-6. Slide valves.
- 7-8. Valve-stems.
- 9-10. Receiving Air-valves.
- 11, 12, 13, 14. Discharge Air-valves.
- 15. Steam-chest Taps.
- 16-17. Steam-chest Bushings.
- 18. Piston-rods.
- 19. Lower Steam-cylinder Head, with Valves and Bushings.
- 20. Piston-plates for Actuating Valve stems
- 21-22. Five-inch Steam-pistons.
- 31. Five-inch Air-piston.
- 32. Seven-inch Air-piston.
- 33. Five-inch Piston Packing-rings.

- 34. Seven-inch Piston Packing-rings.
- 35. Center-piece.
- 36. Piston-rod Stuffing-boxes.
- 37. Piston-rod Stuffing-box Nuts.
- 38. Piston-rod Stuffing-box Glands.
- 39. Lower Receiving-valve Chamber.
- 40. Lower Intermediate-valve Seat.
- 41. Upper Receiving-valve Seat.
- 42. Upper Intermediate-valve Seat.
- 43. Upper Intermediate-valve Chamber.
- 44. Upper Discharge-valve Cap.
- 45. Upper Discharge-valve Seat.
- 46. Lower Discharge-valve Seat.
- 47. Top-head.
- 48. Upper Air-cylinder Gasket.
- 49. Lower Air-cylinder Gasket.
- 50. Upper Steam-cylinder Gasket.
- 51. Lower Steam-cylinder Gasket.
- 52. Cylinder-head Bolts.
- 53. Oil-cups for Air-cylinders.
- 54. Drain-cock.
- 55. Piston-plate Bolt.
- 56. Steam Union stud for Governor.
- 57. Steam Union-nut for Governor.
- 58. Exhaust-pipe Union-stud.
- 59. Exhaust-pipe Union-nut.
- 60. Exhaust-pipe Union-swivel.
- 61. Quarter-inch Nipple.
- 62. Quarter-inch Union.
- 63. Air Union-stud.
- 64. Air Union-nut.
- 65. Air Union-swivel.

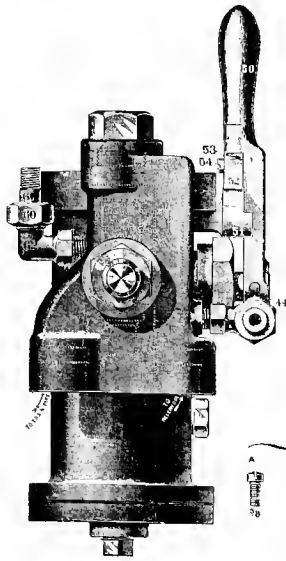

Fig. 1753. Side Elevation.

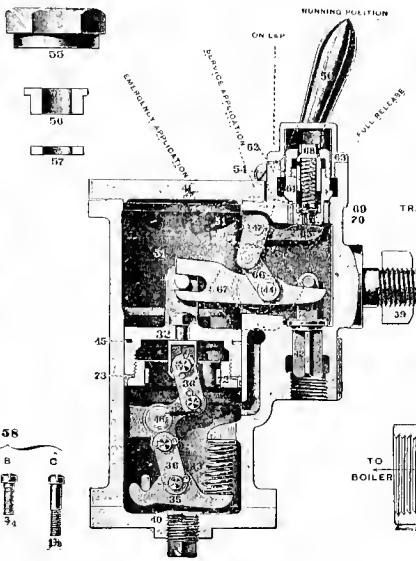

Fig. 1754. Section.

ENGINEER'S BRAKE-VALVE.

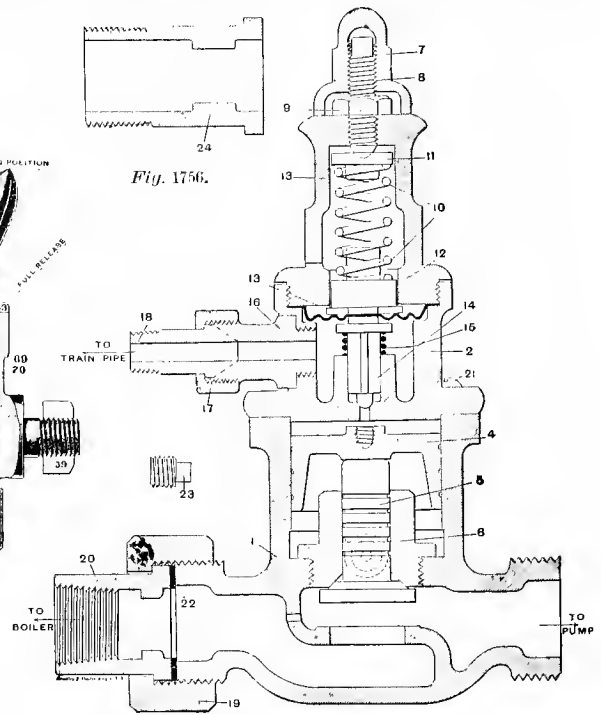

Fig. 1755. Section.
AIR-PUMP GOVERNOR.

AIR BRAKE EQUIPMENT OF NEW YORK AIR BRAKE COMPANY.

NAMES OF PARTS OF ENGINEER'S VALVE.

Figs. 1753-1754.

- | | |
|------------------------------------|--------------------------------------|
| 31. Valve-body. | 56. Eccentric-spindle Packing-gland. |
| 32. Governing-piston. | 57. Eccentric-spindle Packing-ring. |
| 33. Governing-spring. | 58. Head-screws. |
| 34. Bell-crank. | 59. Holding-nut. |
| 35. Spring-lever. | 60. Gage-pipe Union-nut. |
| 36. Connecting-links. | 61. Gage-pipe Union-swivel. |
| 37. Piston Eye-bolt. | 62. Gage-pipe Union-fitting. |
| 40. Lower-head. | 63. Cap. |
| 41. Upper-head. | 64. Feed-valve. |
| 42. Discharge-valve. | 65. Feed-valve Lever. |
| 44. Spindle and Eccentric-pin. | 66. Feed-valve Lever-connection. |
| 45. Piston Packing-ring. | 67. Main-lever. |
| 46. Bell-crank Fulcrum-pin. | 68. Excess Pressure Valve. |
| 47. Feed-valve Lever-pin. | 69. Excess-pressure Valve-spring. |
| 50. Handle. | 70. Excess-pressure Check-valve. |
| 51. Quadrant. | |
| 52. Quadrant-latch. | |
| 53. Quadrant Latch-spring. | |
| 54. Quadrant Latch-pin. | |
| 55. Eccentric-spindle Packing-nut. | |

NAMES OF PARTS OF GOVERNOR. Fig. 1755.

- | | |
|-------------------------------|---|
| 1. Steam-valve Body. | 15. Air-valve Spring. |
| 2. Air-valve Chamber. | 16. Air-union Stud. |
| 3. Regulating-spring Casting. | 17. Air-union Nut. |
| 4. Piston. | 18. Air-union Swivel. |
| 5. Steam-valve. | 19. Steam-union Nut. |
| 6. Steam-valve Guide. | 20. Steam-union Swivel. |
| 7. Cap. | 21. Air-valve Chamber-screw. |
| 8. Adjusting-screw. | 22. Steam union Gasket. |
| 9. Jam-nut. | 23. Drip-plug. |
| 10. Regulating-spring. | 24. Special Steam-union Swivel (used only with No. 2 Pump, in place of No. 20). |
| 11. Upper-spring Washer. | |
| 12. Diaphragm Button. | |
| 13. Diaphragm. | |
| 14. Air-valve. | |

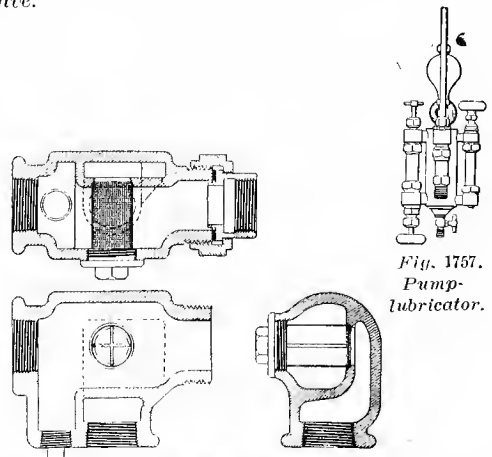

Figs. 1758-1760. Sections.

DRAIN-CUP AND AIR STRAINER. NEW YORK AIR BRAKE COMPANY.

Note.—Other parts of New York Air brake Equipment, not shown, are practically the same as those made by the Westinghouse Air Brake Company, shown in Figs. 1708-1746.

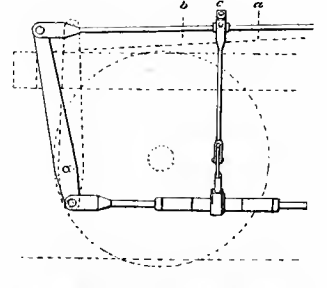
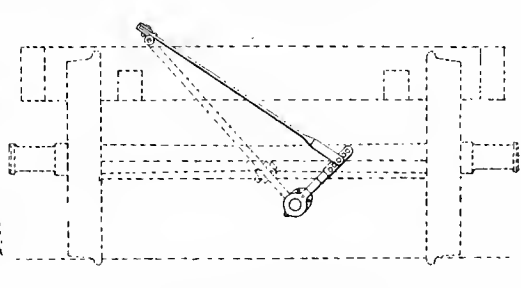
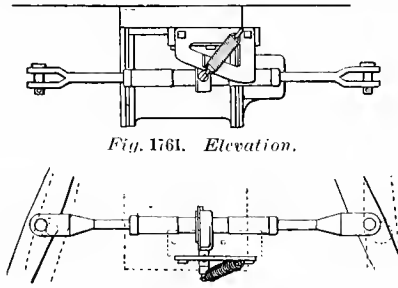

THE HINCKLEY BRAKE SLACK ADJUSTER EQUIPMENT C.

THE HINCKLEY BRAKE SLACK ADJUSTER EQUIPMENT D.

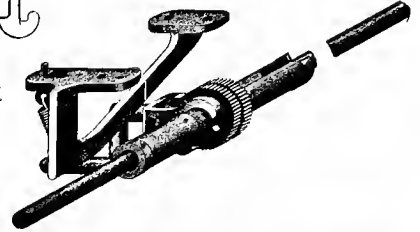
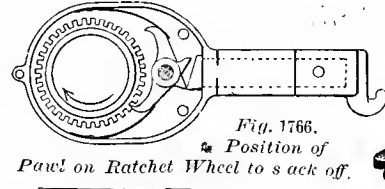
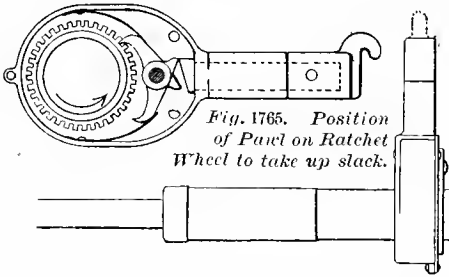
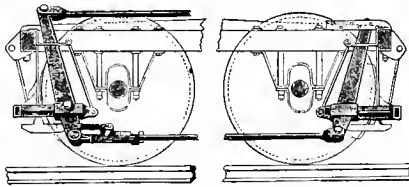

Fig. 1767. Sectional View showing Screw and Application of Ratchet Wheel.

Fig. 1768. View of Adjuster, with Dust Proof Case removed to show Ratchet.

THE HINCKLEY BRAKE SLACK ADJUSTERS.



THE Q. & C. COMPANY.

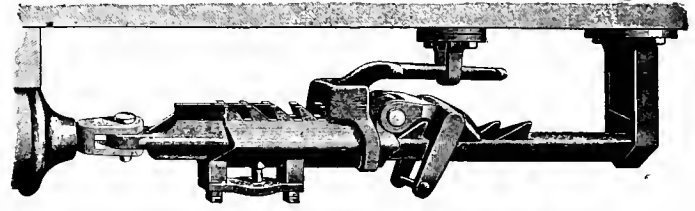

PRATT & LETCHWORTH.

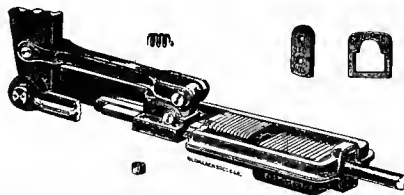

THE Q. & C. COMPANY.

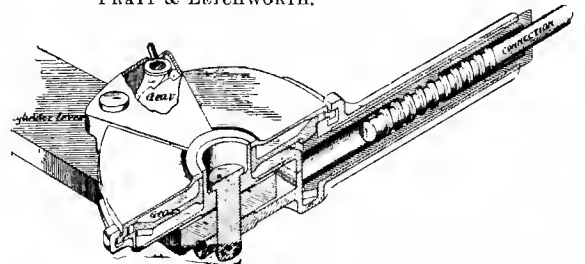

THE Q. & C. COMPANY.

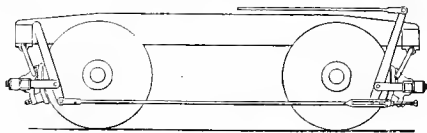

THOMAS PROSSER & SON.

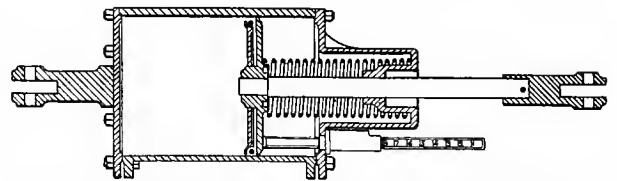

THE SCHROYER-THOMPSON PISTON-TRAVEL INDICATOR.

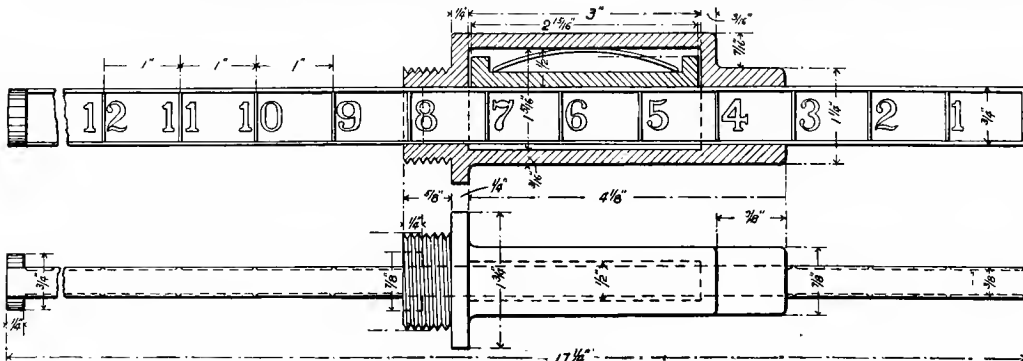

THE SCHROYER-THOMPSON PISTON-TRAVEL INDICATOR.

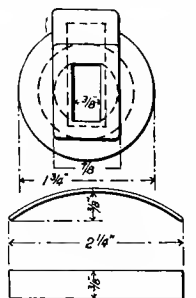

THE SCHROYER-THOMPSON PISTON-TRAVEL INDICATOR.

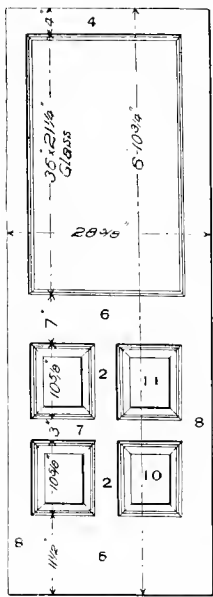
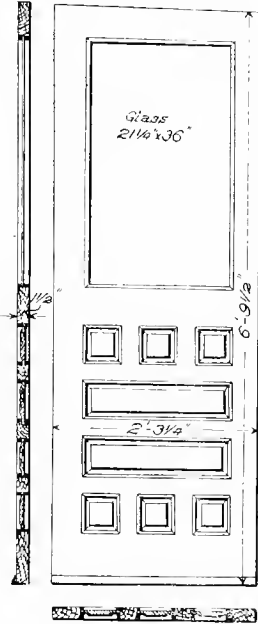

Fig. 1783.
END DOOR OF COACH
PENNSYLVANIA RAILROAD.



Figs. 1784-1786.
END DOOR OF COACH.
NORFOLK & WESTERN RAILROAD.

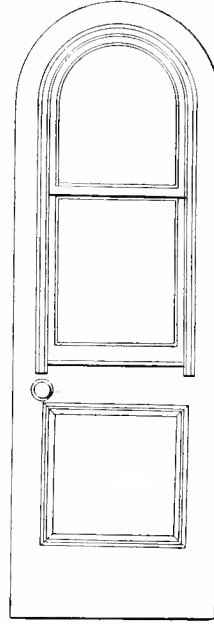

Fig. 1787.
END DOOR OF PRIVATE CAR.
PULLMAN PALACE CAR COMPANY.

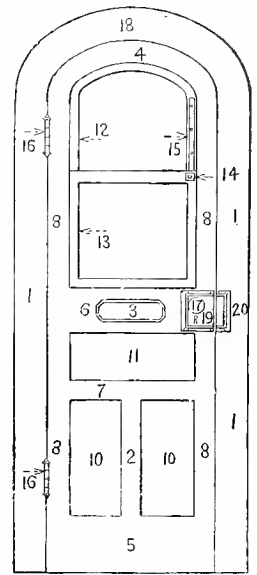

Fig. 1788.
CAR DOOR AND DOOR
CASING.
(An older pattern.)

NAMES OF PARTS OF DOORS.
Figs. 1783-1793.

1. Door-post or Jamb.
2. Door-mullion.
3. Door Name-plate.
4. Top Door-rail.
5. Bottom Door-rail.
6. Middle or Lock Door-rail.
7. Parting Door-rail.
8. Door-stile.
10. Lower or Twin Door-panels.
11. Middle Door panel.
12. Upper Door-sash.
13. Lower Door-sash.
14. Door-sash Bolt.
15. Door-sash Plate.
16. Door-hinge.
17. Door-knob.
18. Door-lintel.
19. Door-lock.
20. Door-lock Keeper.
21. Door-hanger.
22. Door-hook.
23. Door Guards.
24. Vestibule Door-rod.

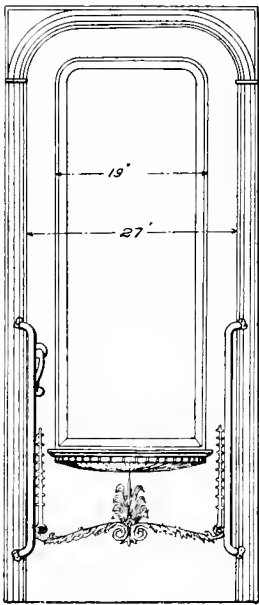

Fig. 1789.
DOOR FOR PULLMAN EXTENDED
VESTIBULE.

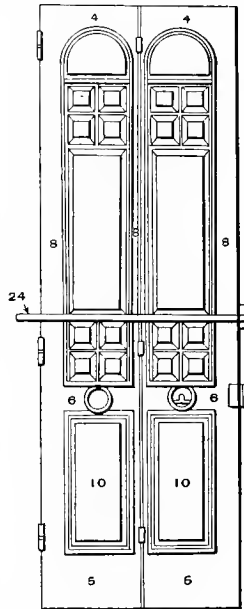

Fig. 1790.
DOOR FOR PULLMAN VESTIBULE.

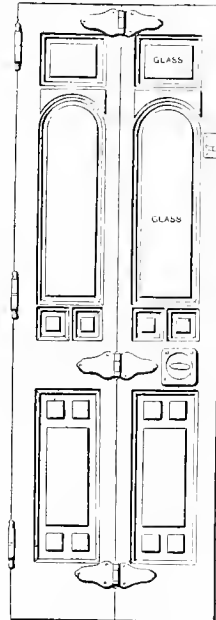

Fig. 1791.
DOOR FOR GOULD
VESTIBULE.

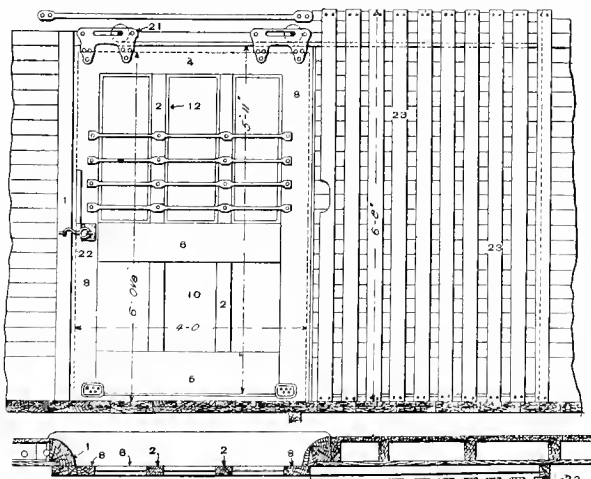

Fig. 1792.
BAGGAGE CAR SIDE-DOOR. NORFOLK & WESTERN RAILROAD.
(177)

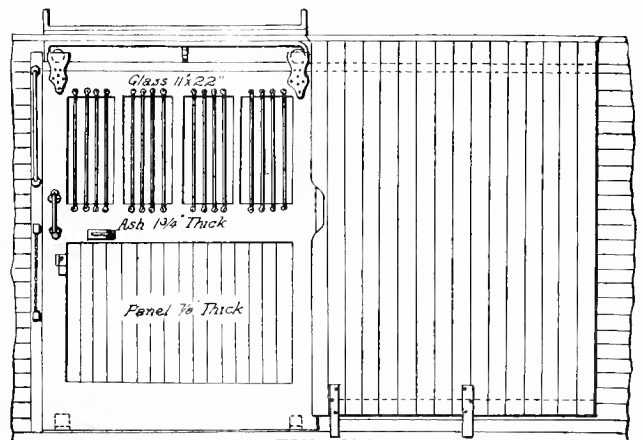

Fig. 1793.
BAGGAGE-CAR SIDE-DOOR. NEW YORK CENTRAL & HUDSON
RIVER RAILROAD.

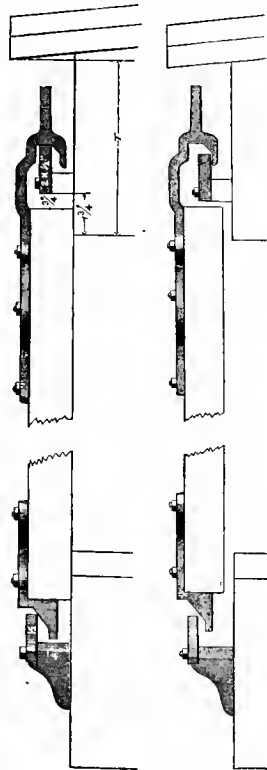

Fig. 1863. Fig. 1864.

MOORE CAR DOOR.

Cross Sections showing Door in place and Door raised preparatory to moving it.

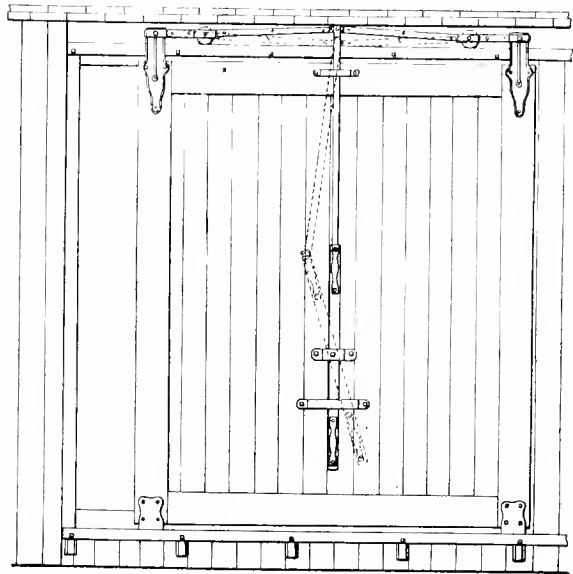

Fig. 1865. Side Elevation.

MOORE CAR DOOR.

Dotted lines show positions of levers and rods when door is raised to open or close it. When not raised by lever its weight wedges it against side of car.

NAMES OF PARTS OF VAN LIEUW'S GRAIN DOOR. Figs. 1866-1869.

- | | | | |
|----------------------|-----------------------|---------------------------|--------------------------------------|
| 1. Lug. | 6. Grain-door Lock. | F. Stanchion Guide-rod. | m. Grain-door Lock, 6, and Latch, 5. |
| 2. Stanchion-socket. | 10. Guide-rod Socket. | g. Grain-door Floor-stop. | n. Grain-door Rail. |
| 3. Stanchion. | B. Door. | H. Grain-door Side-stop. | S. Door-sill. |
| 4. Lift. | C. Grain-door Stile. | I. Chafing-strip. | X. Grain-door Corner-plate. |
| 5. Grain-door Latch. | e. Hand-hold. | O. Grain-door Guide. | |

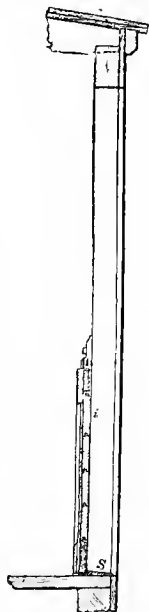

Fig. 1866. Section.

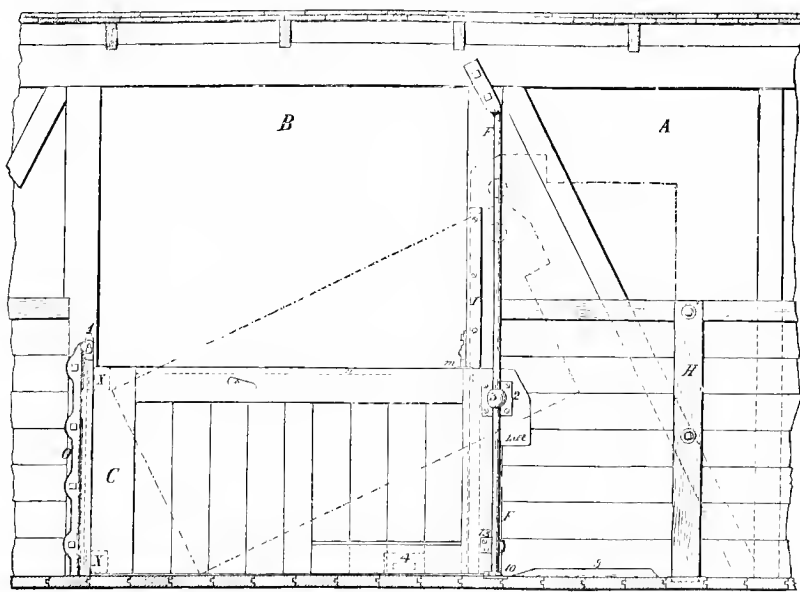

Fig. 1867. Interior Elevation.

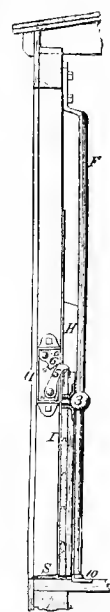

Fig. 1868. Section

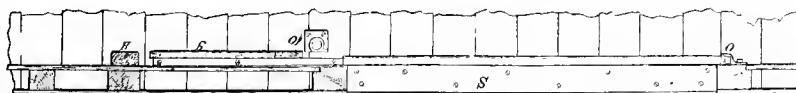

Fig. 1869. Plan
VAN LIEUW'S GRAIN DOOR.

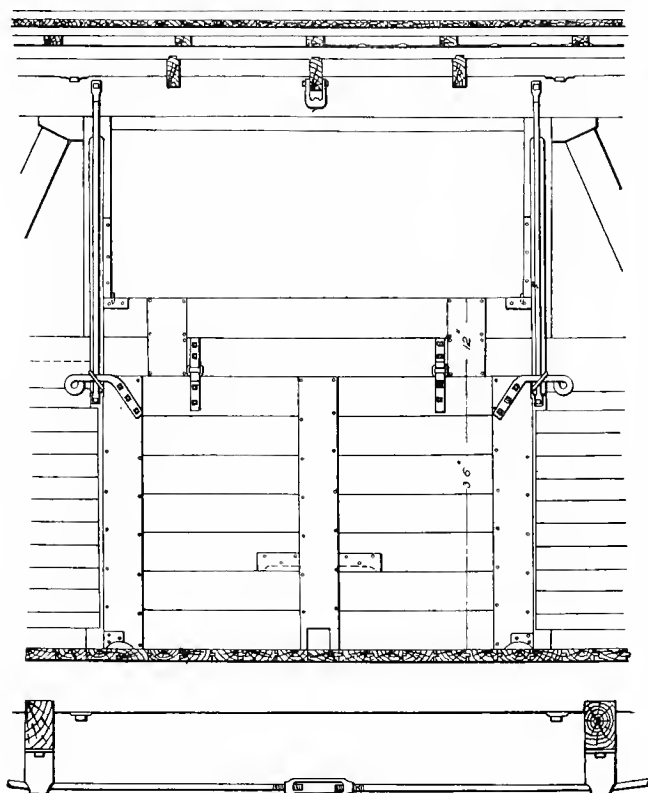

Fig. 1870. Interior Elevation.

THE CHICAGO GRAIN DOOR, MADE BY THE CHICAGO GRAIN DOOR COMPANY.

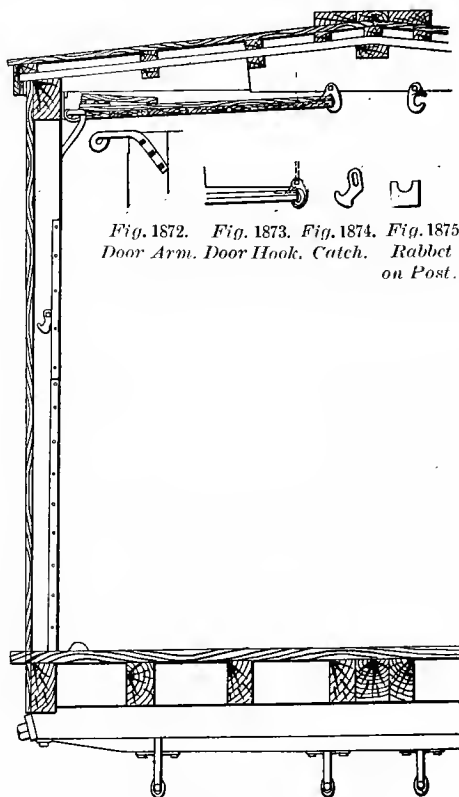

Fig. 1872. Fig. 1873. Fig. 1874. Fig. 1875.
Door Arm. Door Hook. Catch. Rabbit on Post.

Fig. 1871. Half Cross Section.

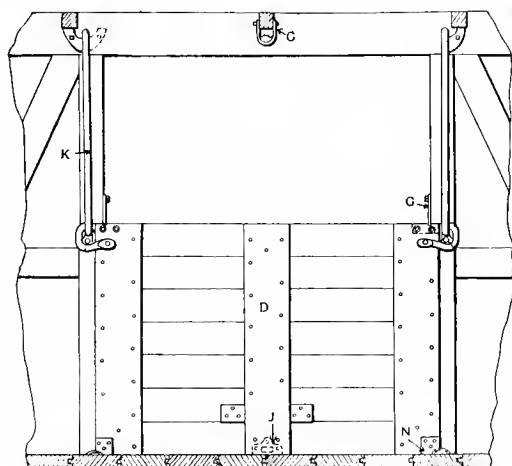

Fig. 1876. Interior Elevation.

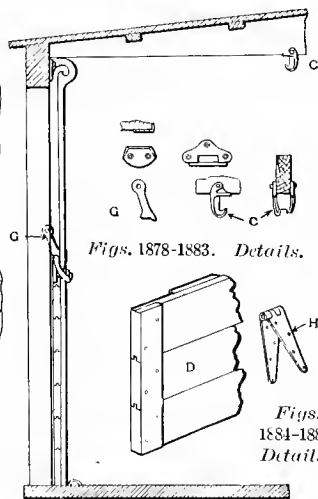

Fig. 1877. Half Cross Section.

NAMES OF PARTS OF MCGUIRE DOOR. Figs. 1876-1895.

- A. Door-post Angle-iron.
- C. Overhead Door-catch or Hook.
- D. Grain-door.
- G. Door-keeper or Dog.
- H. Double-door Hinge.
- J. Door-fulcrum.
- K. Grain-door Rod.
- L. Door Button-head.
- N. Door-shoe.
- P. Door-arm.

NAMES OF PARTS. Figs. 1896-1926.

- A. Plate.
- B. Curline.
- C. Overhead-catch.
- D. Grain-door.
- E. Door-guide.
- F. Inside Door-stop.
- G. Post Angle-iron.
- H. Door Rubbing-plate.
- J. Door-post Angle-iron.
- K. Dog to block door sidewise.
- L. Operating Lever.
- P. Door-post.
- 1. Side-sill.
- 3a. Outer Intermediate-sill.
- 3. Intermediate-sill.
- 4. Center-sill.

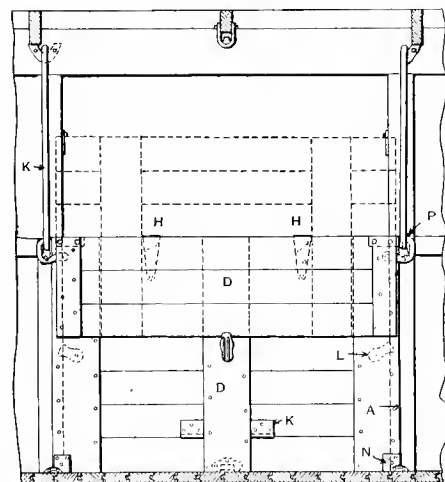

Fig. 1888. Interior Elevation of Double Grain Door.

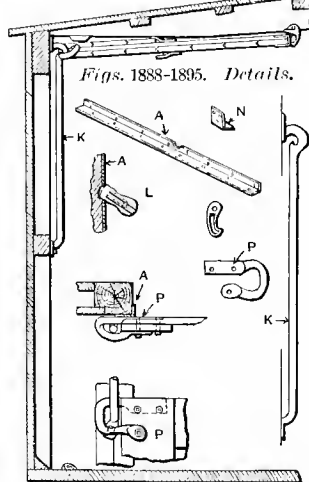

Fig. 1887. Half Cross Section.

THE MCGUIRE GRAIN DOOR, MADE BY THE MCGUIRE MANUFACTURING COMPANY, CHICAGO.

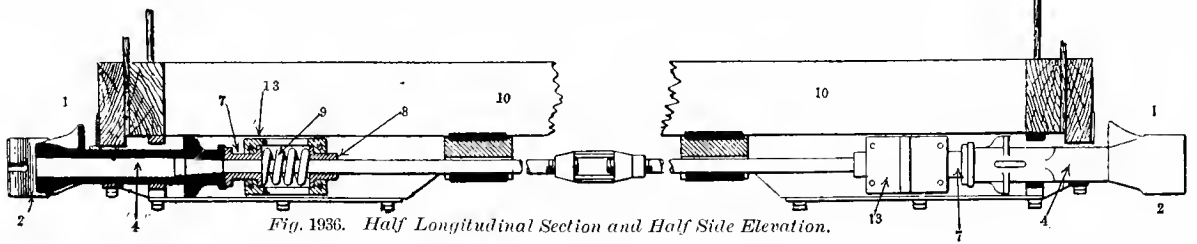

Fig. 1936. Half Longitudinal Section and Half Side Elevation.

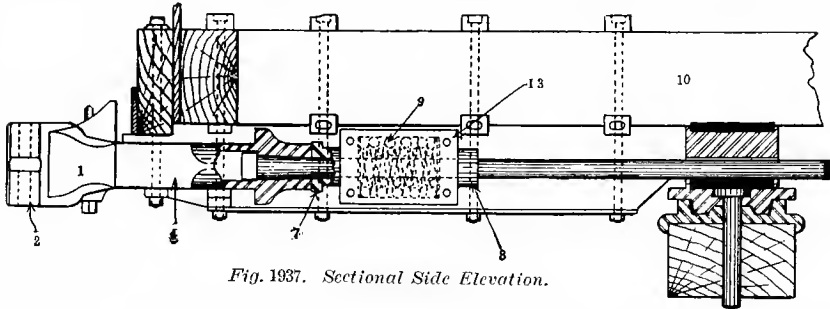

Fig. 1937. Sectional Side Elevation.

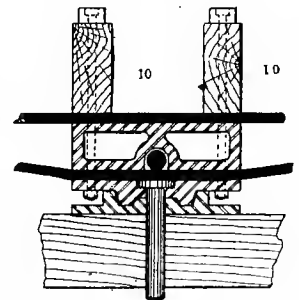

Fig. 1938. Section of Center-plate and Bolster-casting.

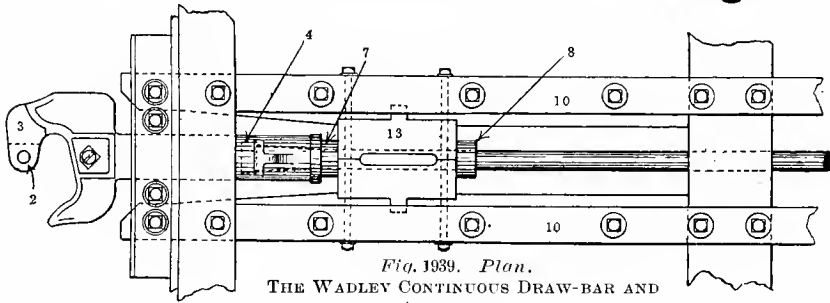

Fig. 1939. Plan.
THE WADLEY CONTINUOUS DRAW-BAR AND ATTACHMENTS.

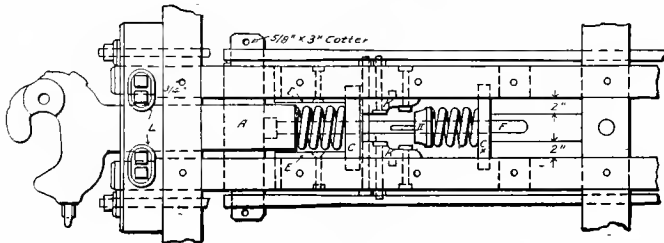

Fig. 1940. Plan.

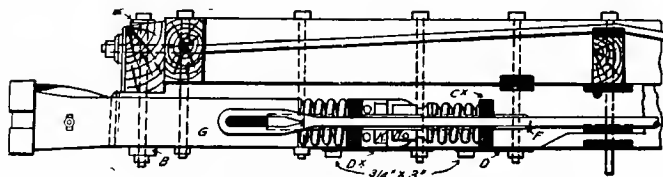
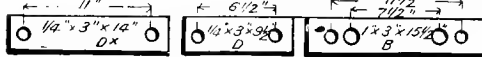

Fig. 1941. Sectional Side Elevation.
THE IMPROVED AMERICAN DRAFT AND BUFFING APPARATUS.
Letters refer to details below.

NAMES OF PARTS OF DRAFT-GEAR.

Figs 1936-2033.

1. Draw-head.
2. Knuckle.
3. Knuckle-pin.
4. Shank.
5. Strap-bolts (Tail-bolt, Fig. 2031).
6. Pocket-strap or Yoke.
7. Front-thimble.
8. Back-thimble.
- 8a. Follower-plates.
9. Draft-spring.
10. Draft-timber.
11. Key-block.
12. Draft-timber Bolts.
13. Draft-spring Case, or Housing for Spring.
14. Tail-bolt.
15. Tail-bolt Key.
16. End-sill Tie-rods.
17. Spring.
18. Unlocking-lever.
19. Carry-iron (Thurmond).
20. Carry-iron Spring.
21. Uncoupling Chain.



Figs. 1941-1942. Follower-supports (4 of each).

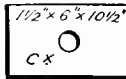

Fig. 1943. Carry-iron (2).

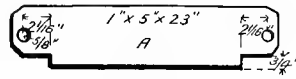

Fig. 1944. Follower-plate (2).

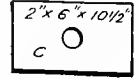

Fig. 1945. Draft-bar (2).

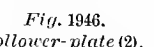
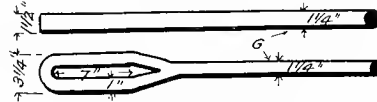

Fig. 1946. Follower-plate (2).



Figs. 1947-1948. Tail-bolt (2).



Figs. 1949-1950. Loop of Continuous Rods (4).

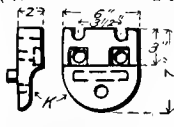

Figs. 1951-1952. Angle-casting (4).

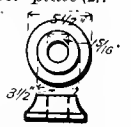

Figs. 1953-1954. Washer (2).

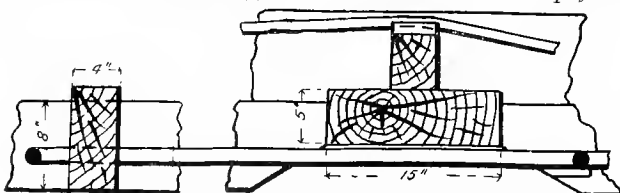

Fig. 1955. Section of Body-bolster and Cross-tie-timber.

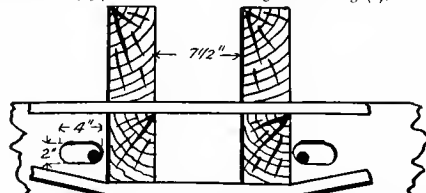
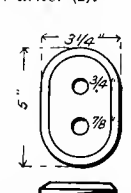

Fig. 1956. Section of Sills, showing Holes in Bolster for Continuous Draft Rods.



Figs. 1957-1958. Bevel Washer (4)

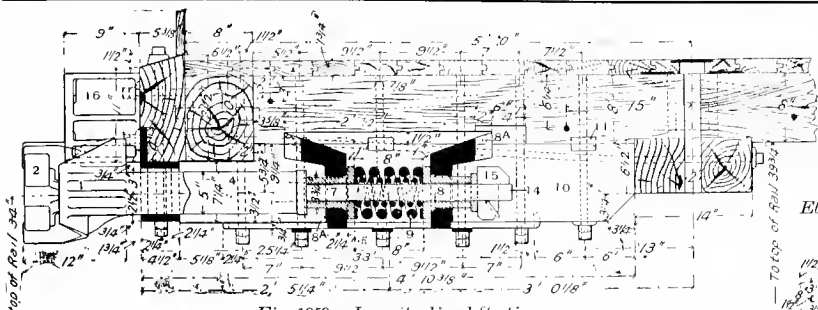

Fig. 1959. Longitudinal Section.

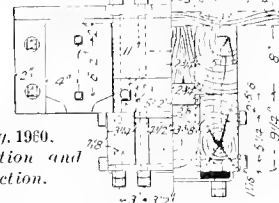

Fig. 1960. Elevation and Section.

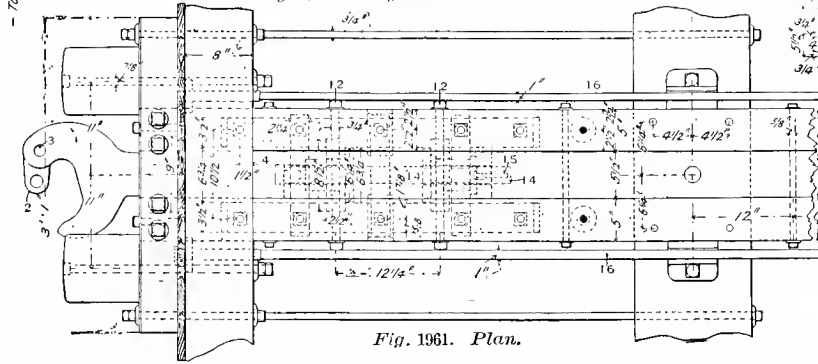
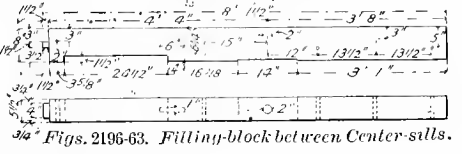
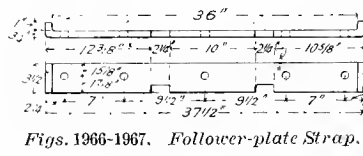
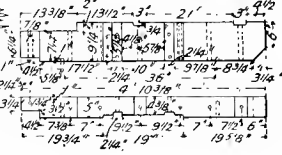

Fig. 1961. Plan.



Figs. 2196-63. Filling-block between Center-sills.

Figs. 1964-65. Draft-timbers.



Figs. 1966-1967. Follower-plate Strap.

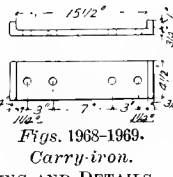

Figs. 1968-1969. Carry-iron.

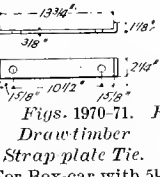

Figs. 1970-71. Draw-timber.

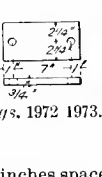

Figs. 1972-1973. Strap plate Tie.

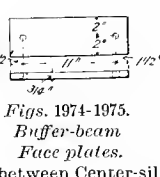

Figs. 1974-1975. Buffer-beam Face plates.

THE GRAHAM DRAFT RIGGING AND DETAILS. For Box-car with 5 1/2 inches space between Center-sills.

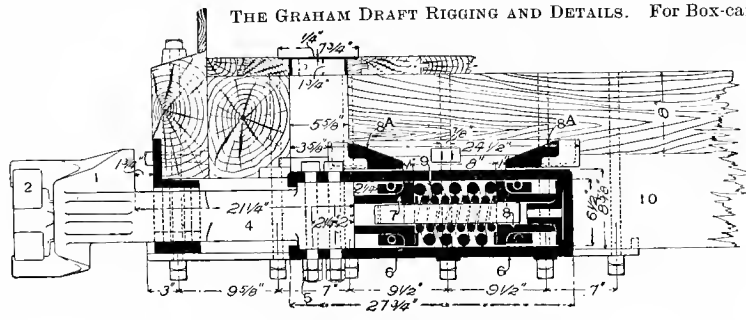

Fig. 1976. Longitudinal Section.

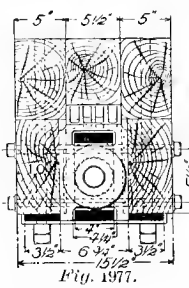

Fig. 1977. Transverse Section.

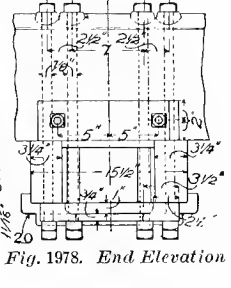

Fig. 1978. End Elevation

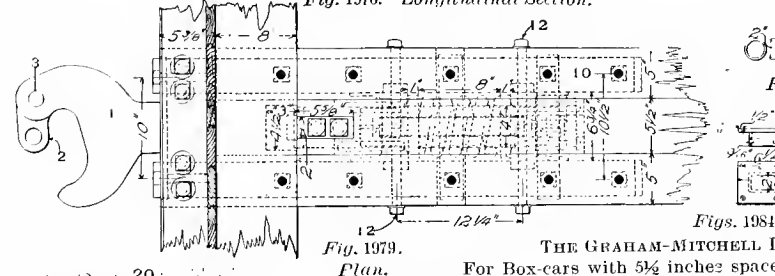
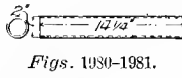
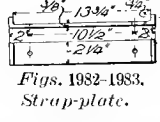

Fig. 1979. Plan.



Figs. 1980-1981.



Figs. 1982-1983. Strap-plate.

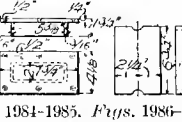

Figs. 1984-1985.

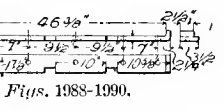

Figs. 1988-1990.

THE GRAHAM-MITCHELL DRAFT RIGGING. For Box-cars with 5 1/2 inches space between Center-sills.

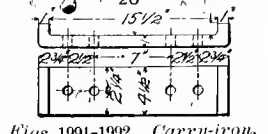

Figs. 1991-1992. Carry-iron.

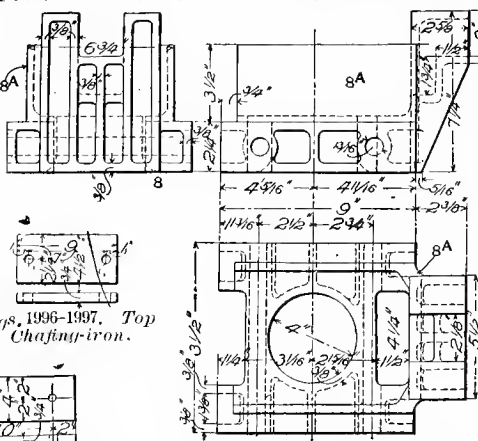

Figs. 1996-1997. Top Chafing-iron.

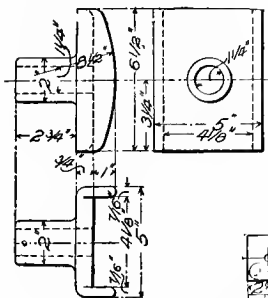

Figs. 1993-1995. Draw-bar Yoke-pocket Guide.

Figs. 1998-1999. Buffer-plank Face-plate.

Figs. 2000-2002. Draw-gear Check-casting

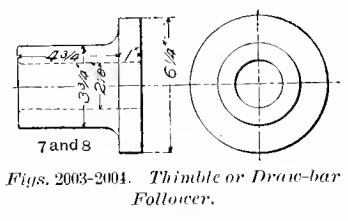

Figs. 2003-2004. Thimble or Draw-bar Follower.

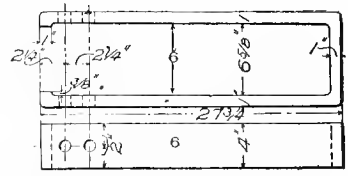

Figs. 20 5-2006. Yoke or Strap-pocket

Attachments are Described on Opposite Page.

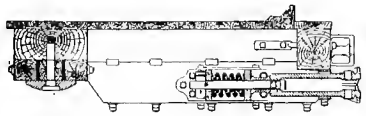

Figs. 2034-2035.

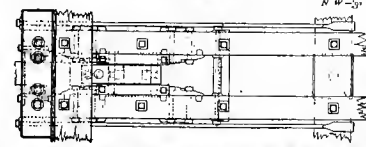
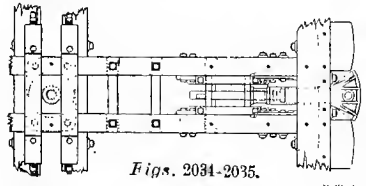

Figs. 2036-2037.

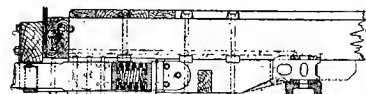
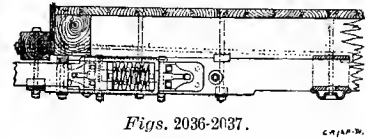

Figs. 2038-2039.

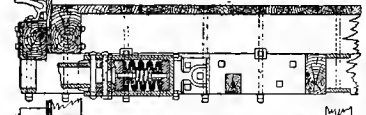
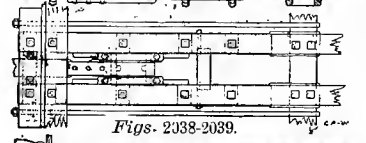

Figs. 2040-2041.

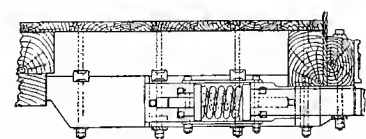
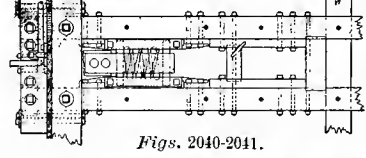

Figs. 2042-2043.

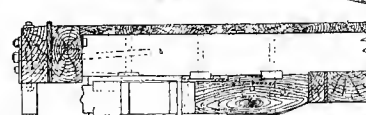
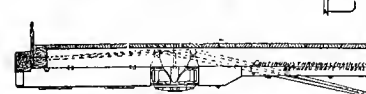
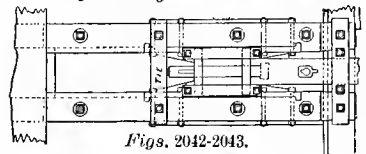

Figs. 2044-2046.

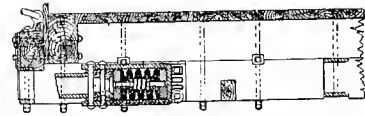
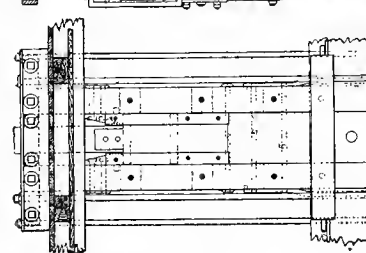

Figs. 2047-2048.

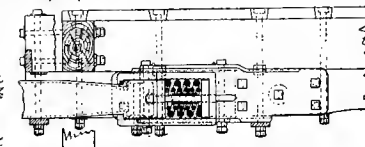
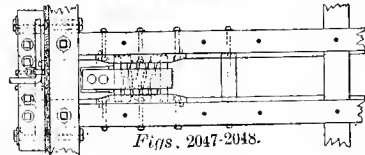

Figs. 2049-2050.

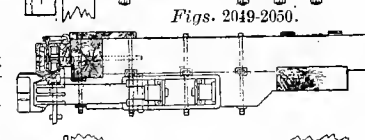
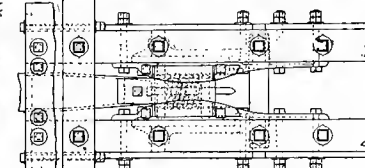

Figs. 2051-2052.

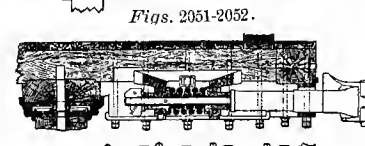
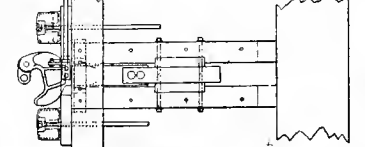

Figs. 2053-2054.

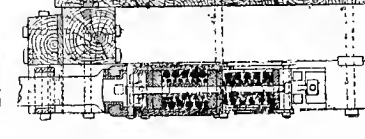
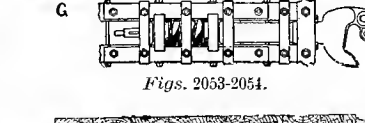

Figs. 2055-2056.

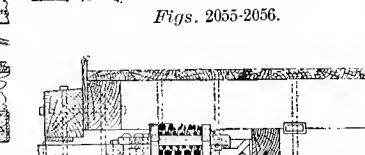
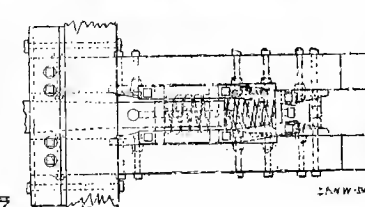

Figs. 2057-2058.

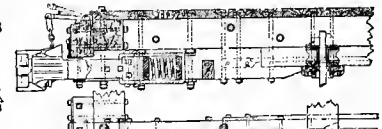
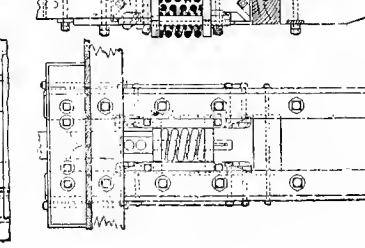

Figs. 2059-2060.

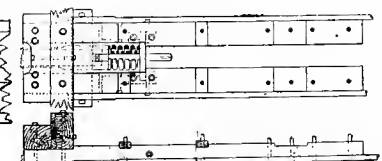
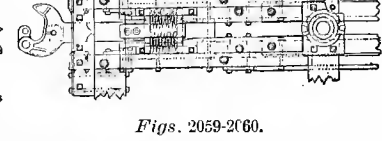

Figs. 2061-2062.

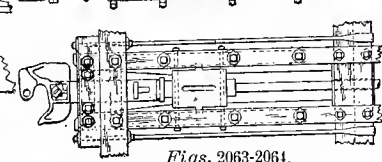
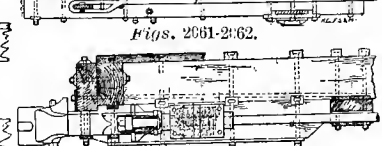

Figs. 2063-2064.

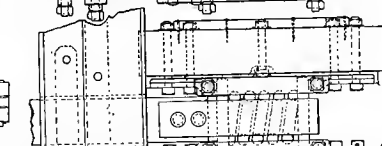
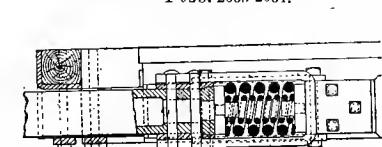

Figs. 2065-2066.

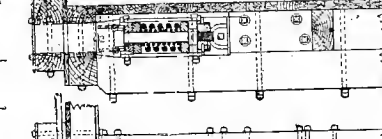
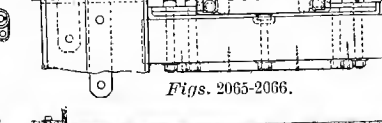

Figs. 2067-2068.

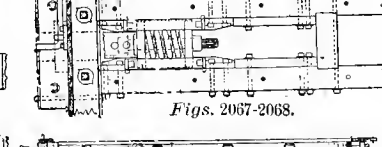

Figs. 2069-2070.

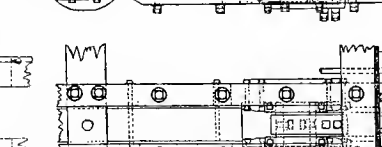
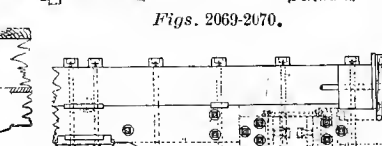

Figs. 2071-2072.

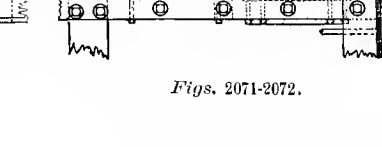

DRAW-BARS AND COUPLERS.

Names of Railroads using Attachments shown on the opposite page and the Date.

- Figs. 2034-2035. Norfolk & Western Railroad, 1892.
- Figs. 2036-2037. Chicago, Rock Island & Pacific Railway, 1891.
- Figs. 2038-2039. Canadian Pacific Railway, 1892.
- Figs. 2040-2041. Michigan Central Railroad, 1892.
- Figs. 2042-2043. East Tennessee, Virginia & Georgia Railroad, 1891.
- Figs. 2044-2046. New York Central & Hudson River Railroad, 1892.
- Figs. 2047-2048. Michigan Central Railroad, 1893.
- Figs. 2049-2050. Union Pacific Railway, 1890.
- Figs. 2051-2052. Chesapeake & Ohio Railway, 1891.

- Figs. 2053-2054. Pennsylvania Railroad, 1892.
- Figs. 2055-2056. Chicago & Northwestern Railway, 1890.
- Figs. 2057-2058. Northern Pacific Railroad, 1892.
- Figs. 2059-2060. Lake Shore & Michigan Southern Railway, 1892.
- Figs. 2061-2062. Kansas City, Ft. Scott & Memphis Railroad, 1892.
- Figs. 2063-2064. Central Railroad of Georgia, 1892.
- Figs. 2065-2066. Chicago, Burlington & Quincy Railroad, 1892.
- Figs. 2067-2068. Michigan Central Railroad, 1892.
- Figs. 2069-2070. Denver & Rio Grande Railroad, 1889.
- Figs. 2071-2072. Wabash Railroad, 1892.

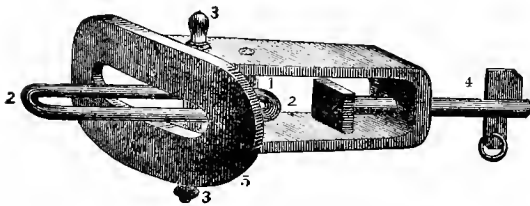

Fig. 2073. Link and Pin Coupler.
Wrought iron, forged.

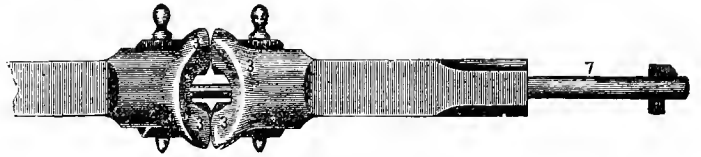

Fig. 2074. Link and Pin Coupler.
Malleable cast iron.

1, Rivet. 2, Link. 3, Pin. 4, Tail-bolt. 5, Draw-head.

The Link and Pin types of Couplers are now nearly obsolete on Steam Railroads.

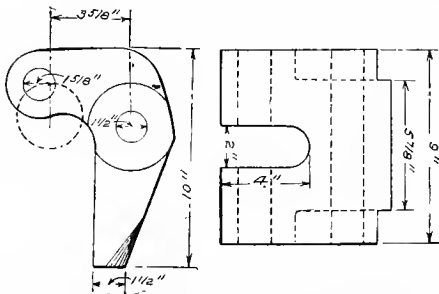

Fig. 2078. Plan. Fig. 2079. End Elevation.

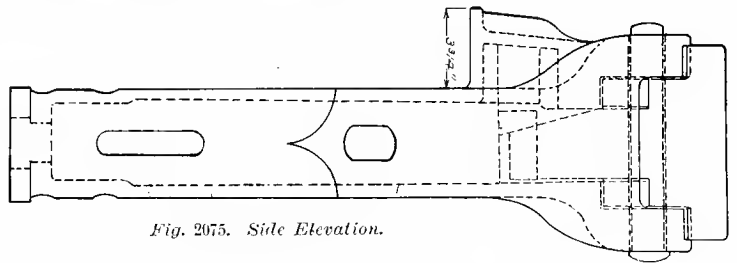
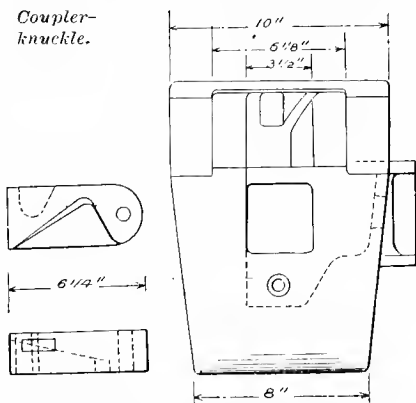

Fig. 2075. Side Elevation.



Figs. 2080-2081. The Lock. Fig. 2077. End Elevation of Draw-head.

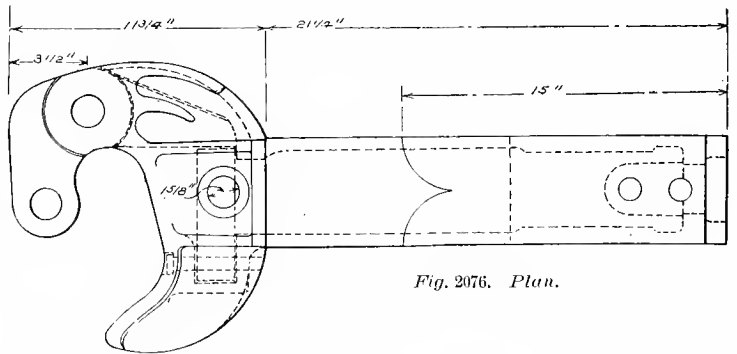

Fig. 2076. Plan.

THE AMERICAN CAR COUPLER.

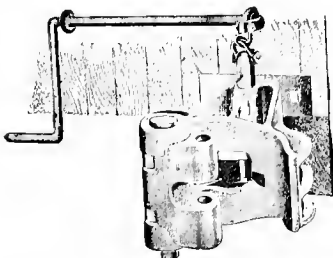

Fig. 2082. Coupler and Unlocking-device.

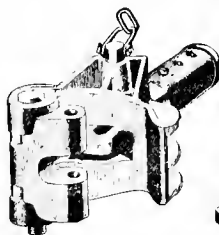

Fig. 2083. Coupler Alone.

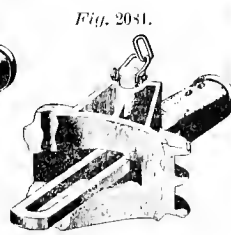

Fig. 2084. Coupler Broken, showing use of Emergency Link.

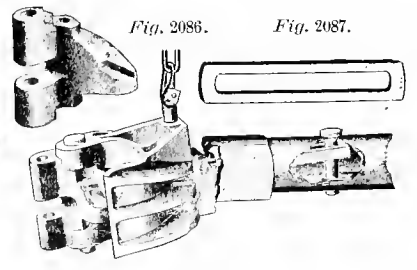
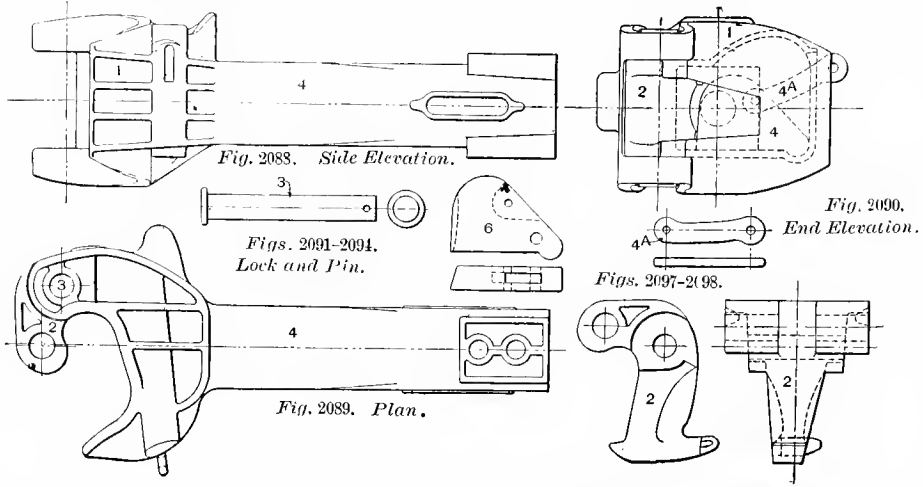
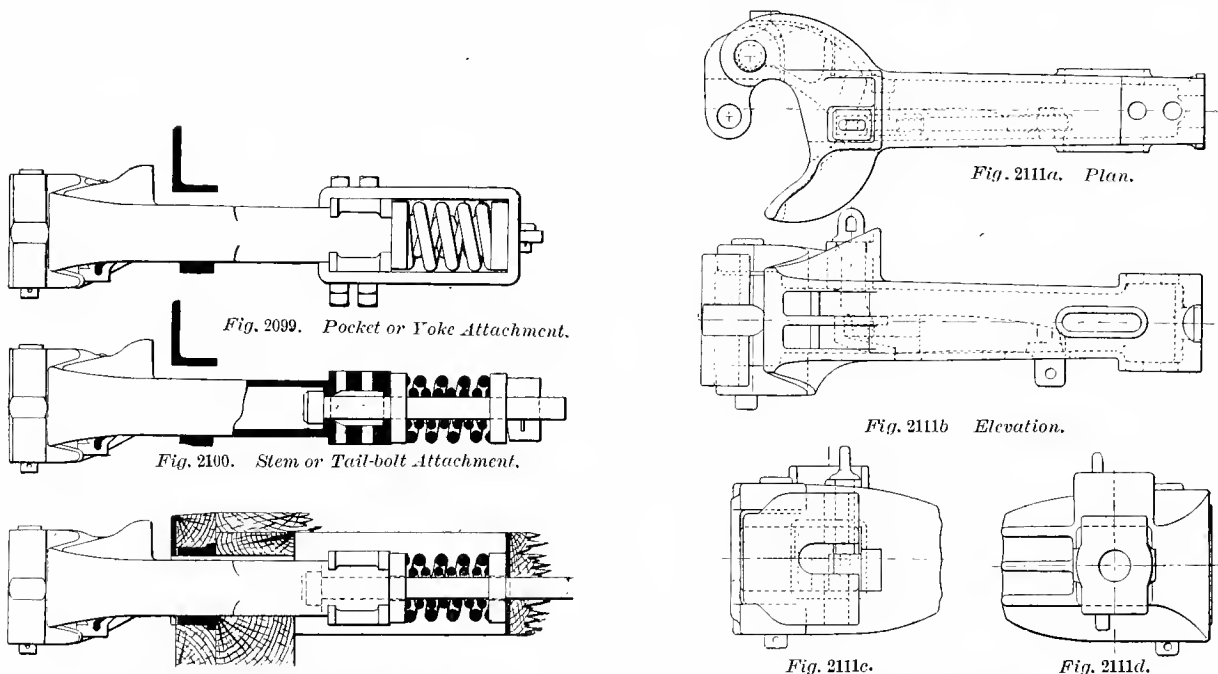

Fig. 2085. Coupler Broken and held from Falling to the Track by the Emergency Link.

Numbers Refer to List of Names with Figs. 2177-2178.



THE BUCKEYE LITTLE GIANT COUPLER.



COMMON TYPES OF DRAW-BAR ATTACHMENTS.

THE CHICAGO AUTOMATIC COUPLER.

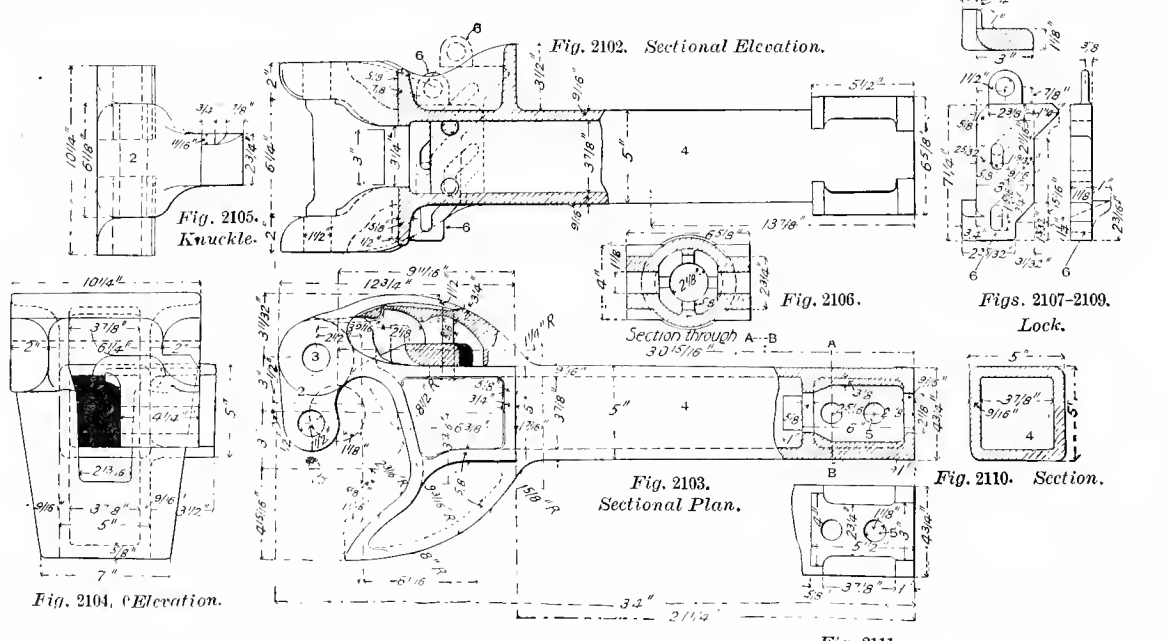

THE CALIFORNIA COUPLER.

Numbers Refer to List of Names with Figs. 2177-2178

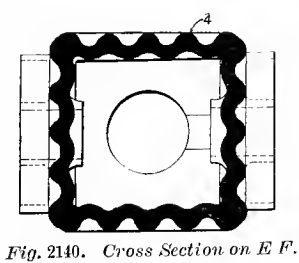
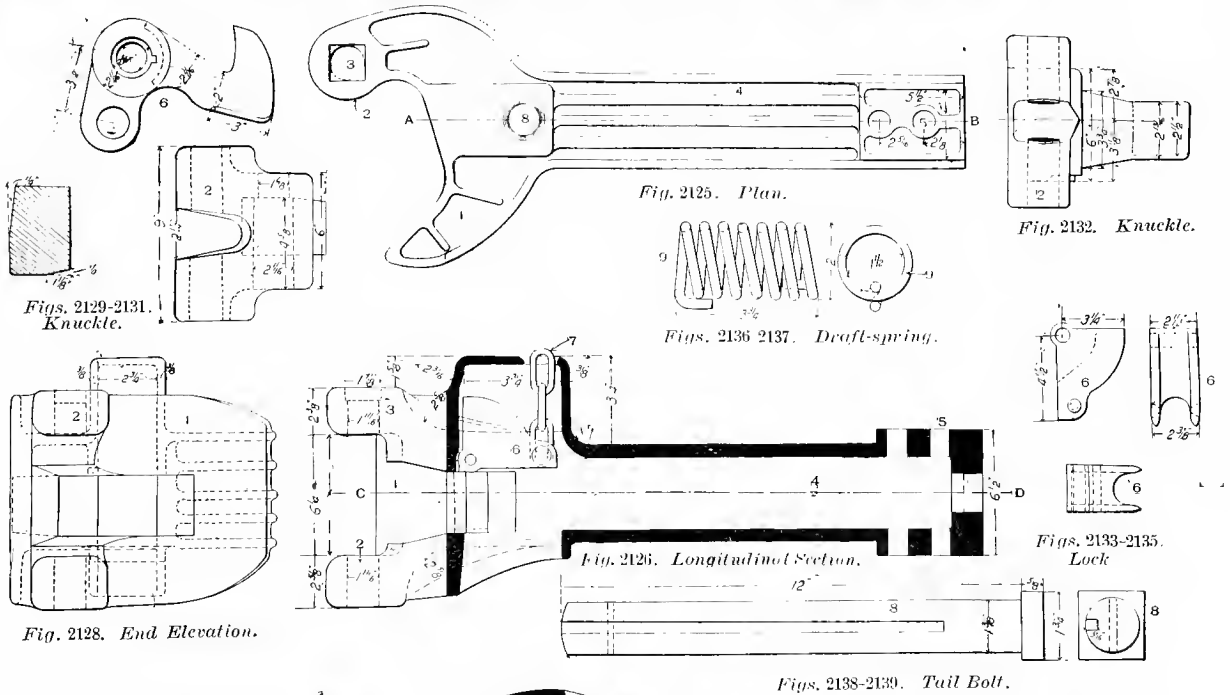
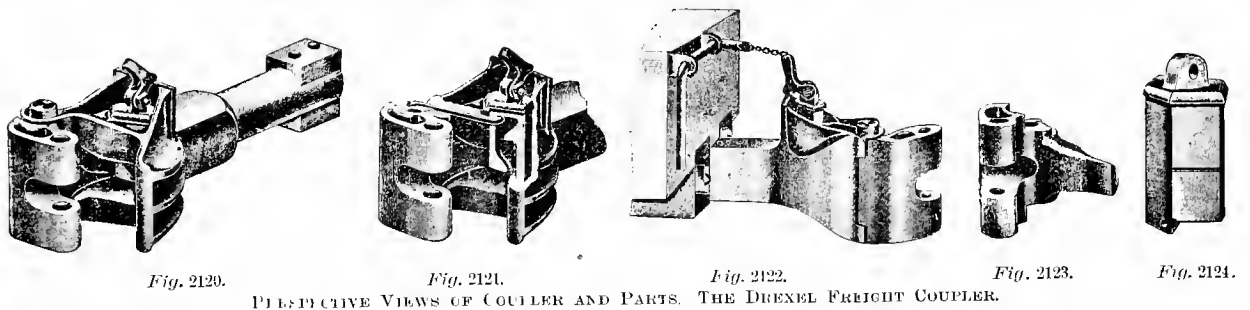
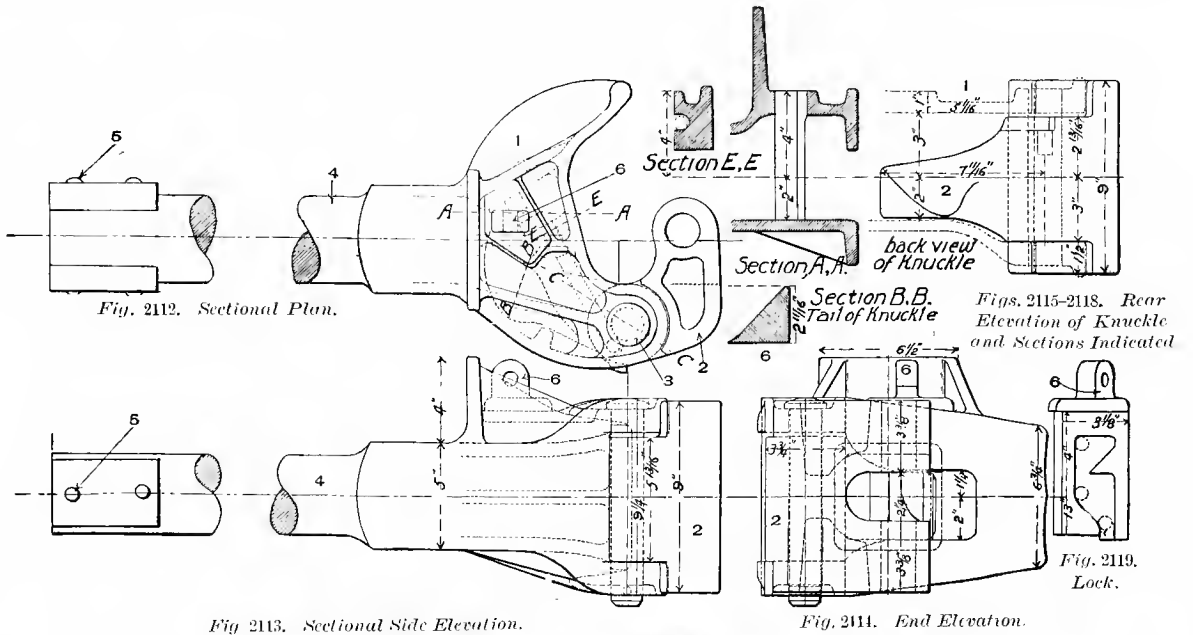

THE ELLIOTT FREIGHT COUPLER.

Numbers Refer to List of Names on Opposite Page.

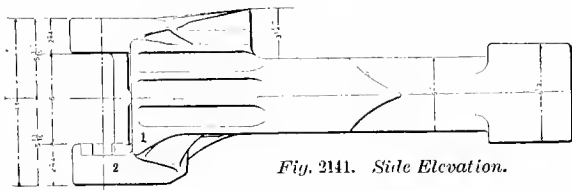

Fig. 2141. Side Elevation.

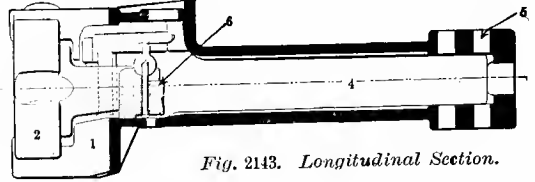

Fig. 2143. Longitudinal Section.

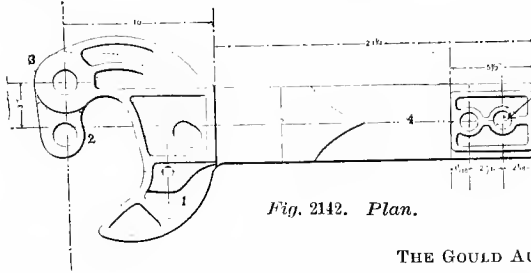

Fig. 2142. Plan.

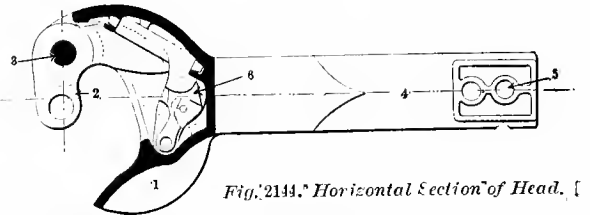

Fig. 2144. Horizontal Section of Head.

THE GOULD AUTOMATIC FREIGHT COUPLER.

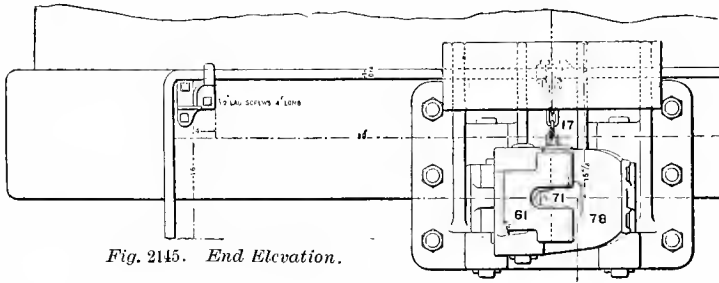

Fig. 2145. End Elevation.

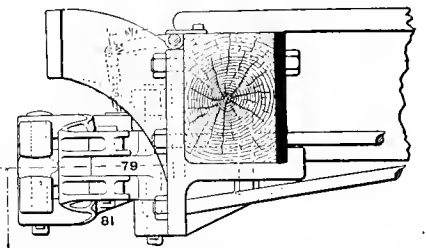

Fig. 2146. Side Elevation.

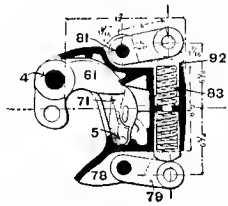

Fig. 2147. Horizontal Section.

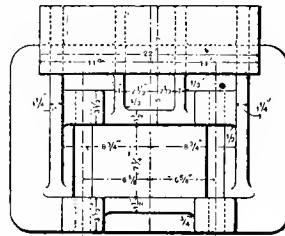

Fig. 2148. Front Elevation of Buffer Head
THE GOULD TENDER-BOOK.

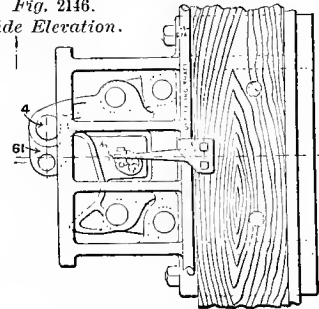

Fig. 2149. Plan.

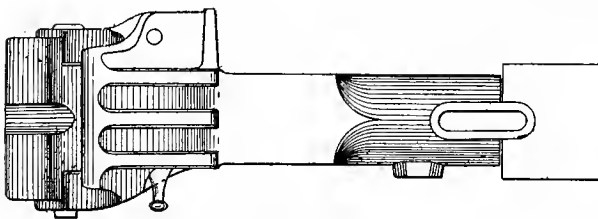

Fig. 2150. Side Elevation.

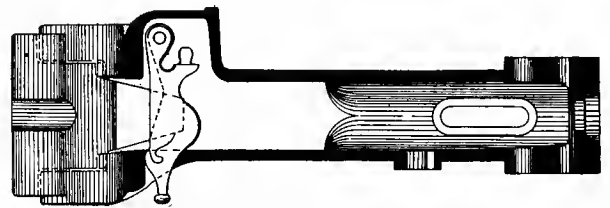

Fig. 2152. Part Section, showing Lock.

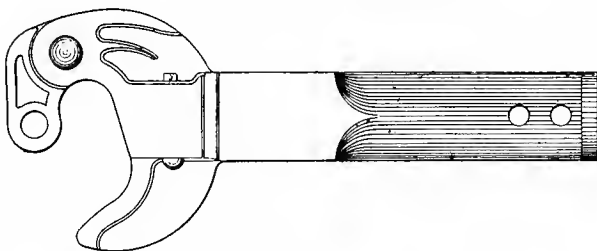

Fig. 2151. Plan.

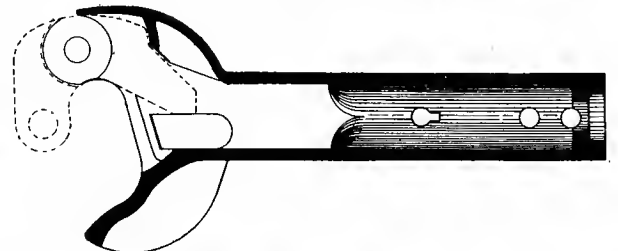

Fig. 2153. Part Section, showing Lock and Knuckle.

HINSON FREIGHT COUPLER.

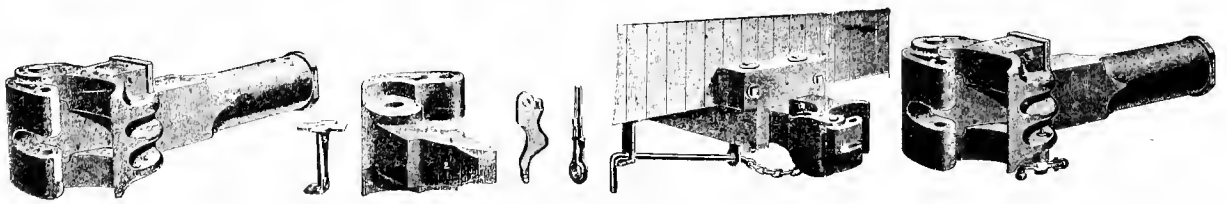

Fig. 2154.

Fig. 2155.

Fig. 2156.

Figs. 2157-2158.

Fig. 2159.

Fig. 2160.

PERSPECTIVE VIEWS OF THE HINSON FREIGHT COUPLER AND ITS PARTS.

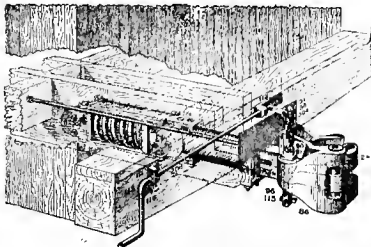
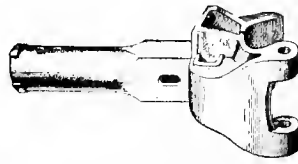
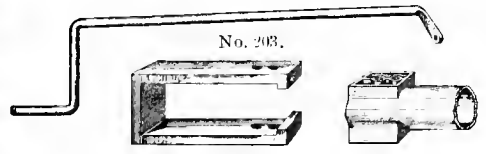

Fig. 2161. The Janney Freight Draw-bar and Attachments.



No. 86. Fig. 2162.



No. 203, No. 205, No. 86s. Figs. 2163-2165.



No. 113, No. 111, No. 115, No. 112, No. 90, Figs. 2166-2172.

No. 202, Fig. 2173.

No. 86sts, Fig. 2074.

No. 2a, Fig. 2175.

No. 95, Fig. 2176.

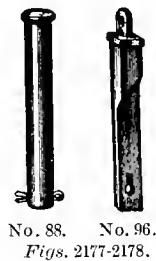

No. 88, No. 96, Figs. 2177-2178.



No. 91, No. 207, Figs. 2179-2180.

No. 206, No. 114, Figs. 2181-2182.

THE JANNEY FREIGHT COUPLER, WITH YOKE ATTACHMENTS.

NAMES OF PARTS OF COUPLERS. Figs. 2088-2144.

1. Draw-head.
2. Knuckle.
3. Pin.
4. Shank.
5. Strap or Yoke-bolls.
6. Lock.

NAMES OF PARTS OF GOULD TENDER HOOK. Figs. 2145-2149.

4. Knuckle-pin.
5. Lock-pin.
17. Unlocking-lever Chain.
61. Knuckle.
71. Lock.
78. Coupler-head.
79. Side-link.
81. Side-link Pin.
82. Spring-cap.
83. Spring.

NAMES OF PARTS OF JANNEY FREIGHT COUPLER. Figs. 2161-2182.

- | | |
|---|------------------------------|
| 2a. Wrought-knuckle. | 114. Angle Clip-bolt. |
| 86. Coupler. | 115. Split-key. |
| 86s. Coupler Solid Liner-blocks. | 202. Liner-block. |
| 86sts. Coupler Solid Liner-blocks and Slotted-tail. | 203. Uncoupling-lever. |
| 88. Knuckle-pin. | 204. Uncoupling-lever Chain. |
| 90. Clevis. | 205. Spring-pocket. |
| 91. Clevis-pin. | 206. Draft-spring Bolt. |
| 95. Draft-spring. | 207. Draft-spring Ferrule. |
| 96. Locking-spring. | |
| 111. Uncoupling-lock. | |
| 112. Keeper. | |
| 113. Angle-clips. | |

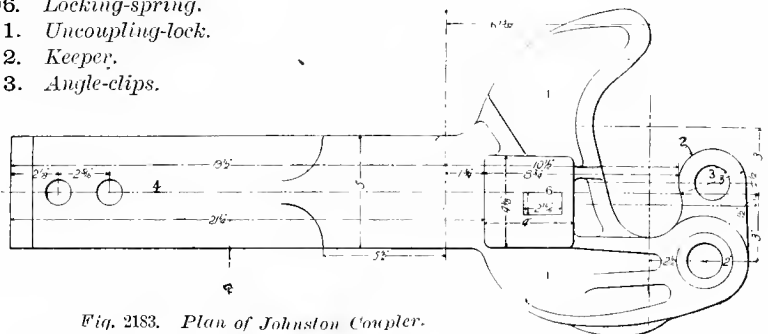

Fig. 2183. Plan of Johnston Coupler.

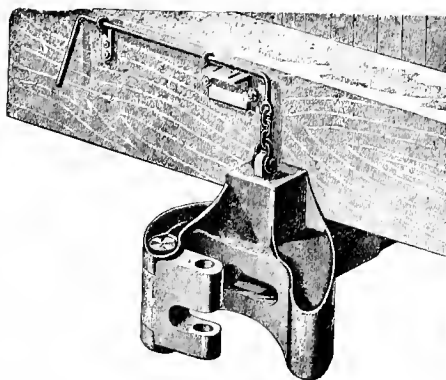

Fig. 2184.

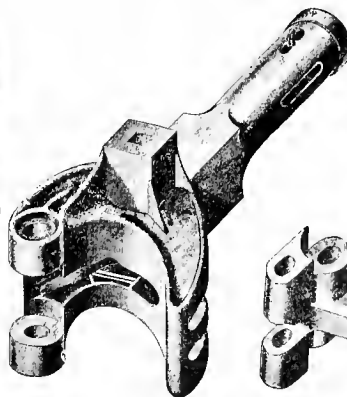

Fig. 2185.

Fig. 2186.

Fig. 2187.

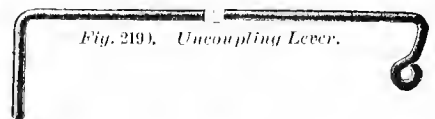

Fig. 2189. Uncoupling Lever.

Fig. 2188.

Fig. 2189.

Figs. 2184-2190. Perspective Views of Coupler and Parts.

JOHNSTON FREIGHT COUPLER AND PARTS.

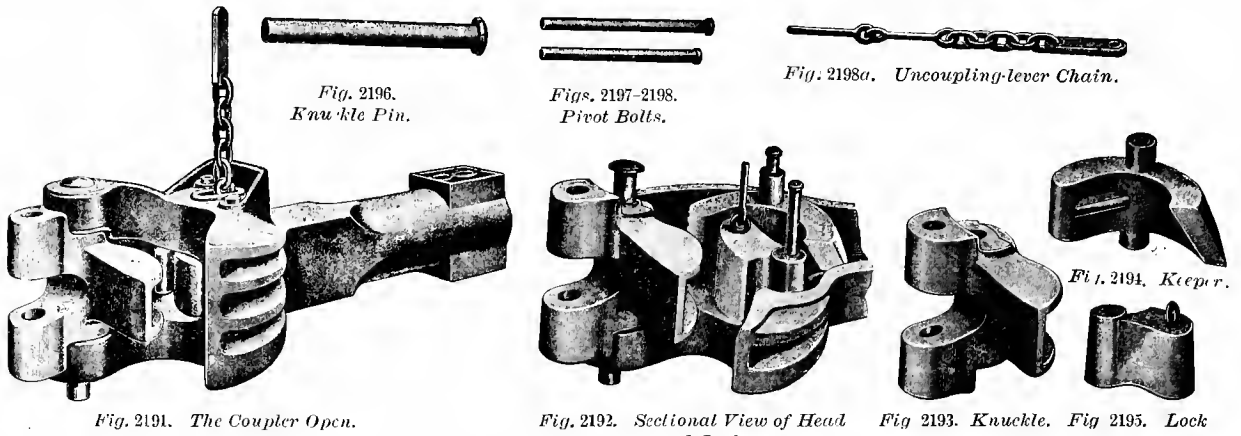

THE POOLEY FREIGHT COUPLER AND PARTS.

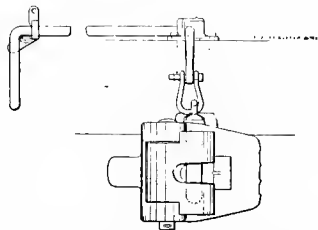

Fig. 2199. End Elevation.

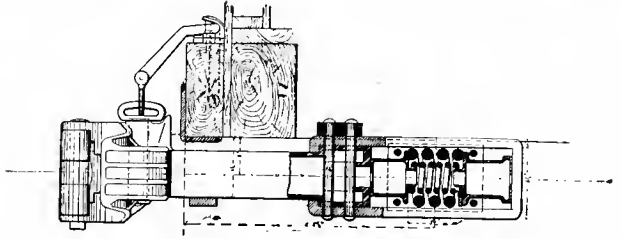

Fig. 2200. Sectional Side Elevation.

NAMES OF PARTS OF COUPLERS. Figs. 2073-2144.

1. Draw-head.
2. Knuckle.
3. Pin.
4. Shank.
5. Strap or Yoke-bolts.
6. Lock.

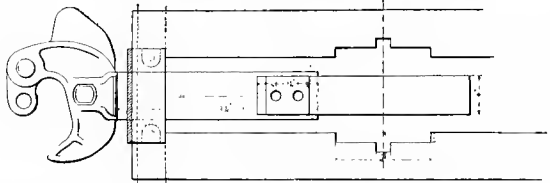

Fig. 2201. Plan.

THE SMILLIE FREIGHT COUPLER.

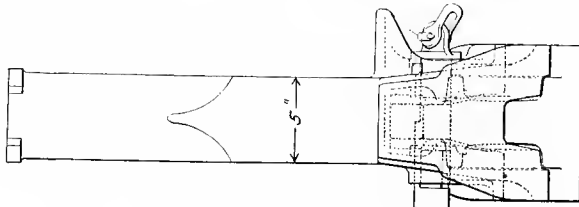

Fig. 2202. Side Elevation.

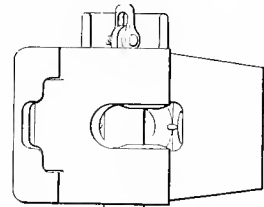

Fig. 2203. Front Elevation.

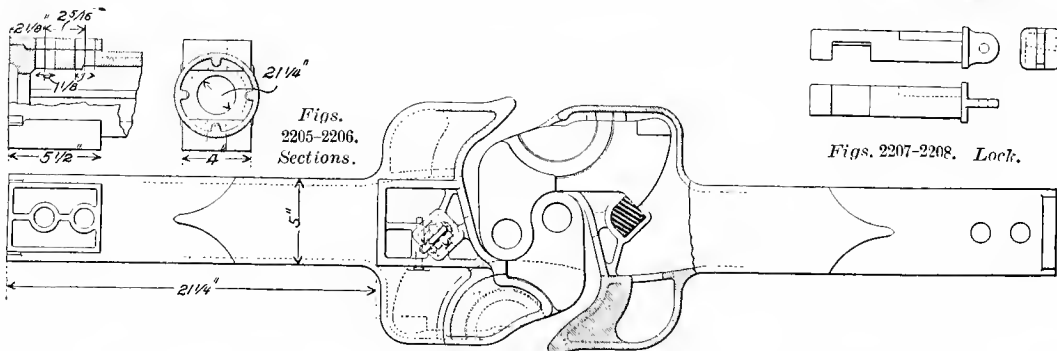

Fig. 2204. Plan of Couplers Locked.

THE IMPROVED STANDARD FREIGHT COUPLER.

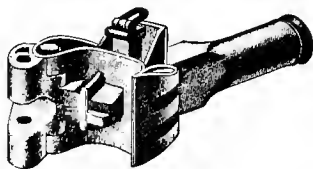

Fig. 2209.

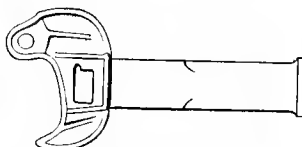

Fig. 2210.



Fig. 2211.



Fig. 2212.

THURMOND-McKEEN FREIGHT COUPLER AND PARTS.

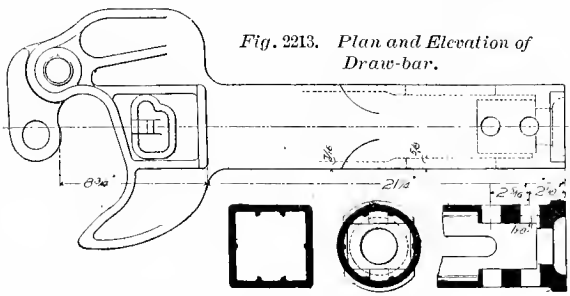

Fig. 2213. Plan and Elevation of Draw-bar.



Figs. 2214-2216. Sections.

THURMOND-McKEEN FREIGHT COUPLER.

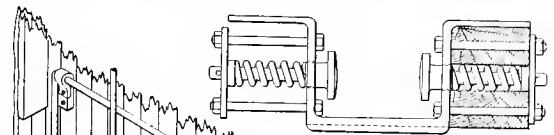
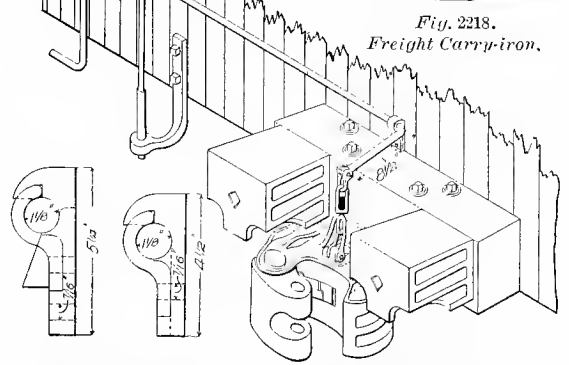

Fig. 2218. Freight Carry-iron.



Figs. 2219-2220. Uncoupling Rod Brackets. Perspective View, showing application of Coupler.

THURMOND-McKEEN FREIGHT COUPLER AND ITS FITTINGS.

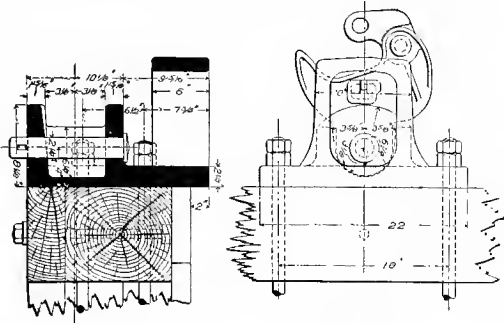

Fig. 2221. Longitudinal Section.

Fig. 2222. Plan.

THURMOND-McKEEN LOCOMOTIVE TENDER-HOOK.

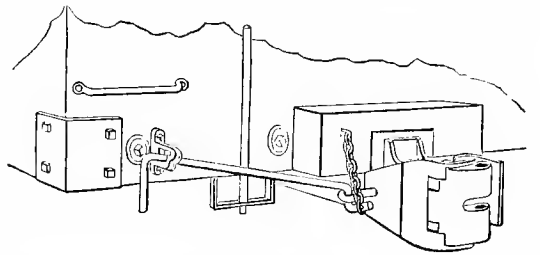

Fig. 2223.

Perspective View of Coupler, Hand-rod and Bracket.

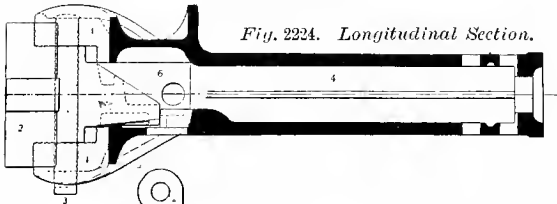

Fig. 2224. Longitudinal Section.

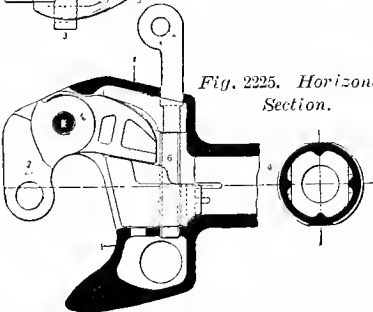

Fig. 2225. Horizontal Section.

Fig. 2226. Cross Section. THE TROJAN FREIGHT COUPLER.

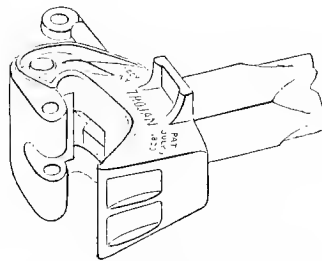

Fig. 2227. Perspective View of Draw-head.

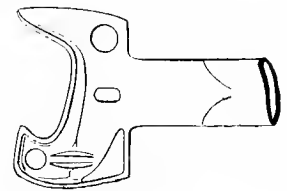

Fig. 2228. Plan of Draw-head.

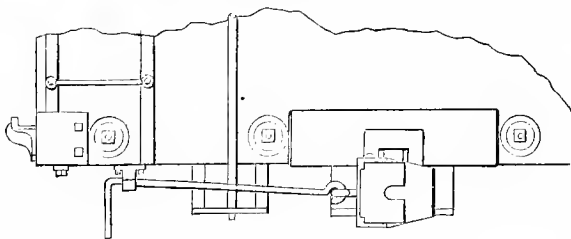

Fig. 2229. Coupler, Hand Rod and Bracket.

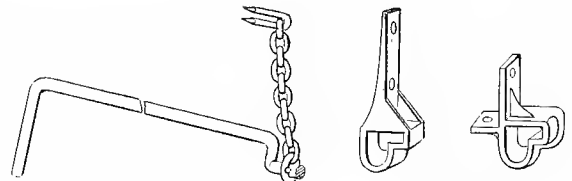

Fig. 2230. Hand Rod.

Figs. 2231-2232. Bracket for Face of End-sill, Corner of Sill.

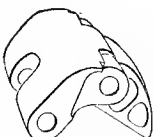

Fig. 2233. Knuckle.



Fig. 2234. Knuckle Lock.

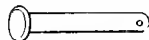

Fig. 2235. Knuckle Pin.

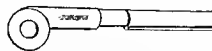

Fig. 2236. Operating Rod.



Fig. 2237. Finger.



Figs. 2238-2239. Bracket for Face of Sill, Under-side of Sill.

THE TROJAN FREIGHT COUPLER AND PARTS.

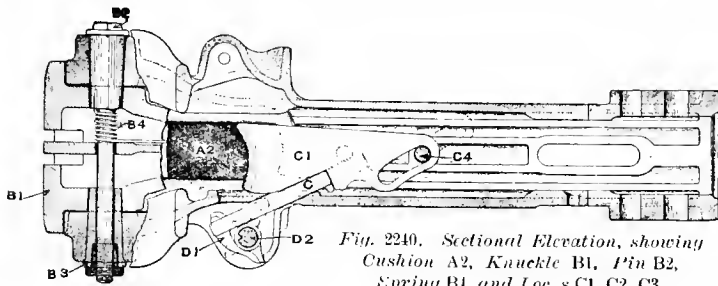

Fig. 2240. Sectional Elevation, showing Cushion A2, Knuckle B1, Pin B2, Spring B1, and Locks C1, C2, C3.

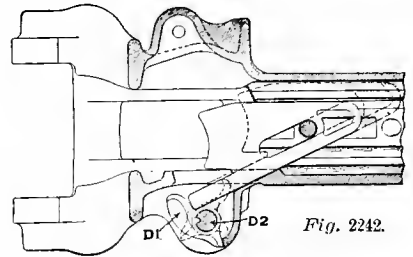

Fig. 2242. Sectional Elevation, showing Incline-locks.

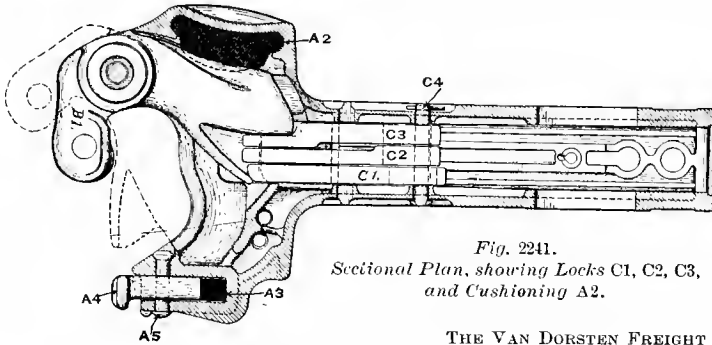

Fig. 2241. Sectional Plan, showing Locks C1, C2, C3, and Cushioning A2.

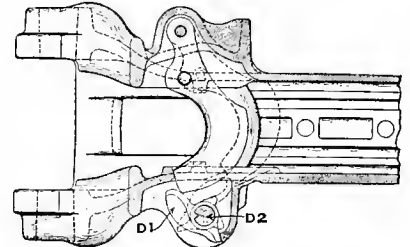

Fig. 2243. Sectional Plan, showing Swing Locks.

THE VAN DORSTEN FREIGHT COUPLER.

PASSENGER COUPLERS.

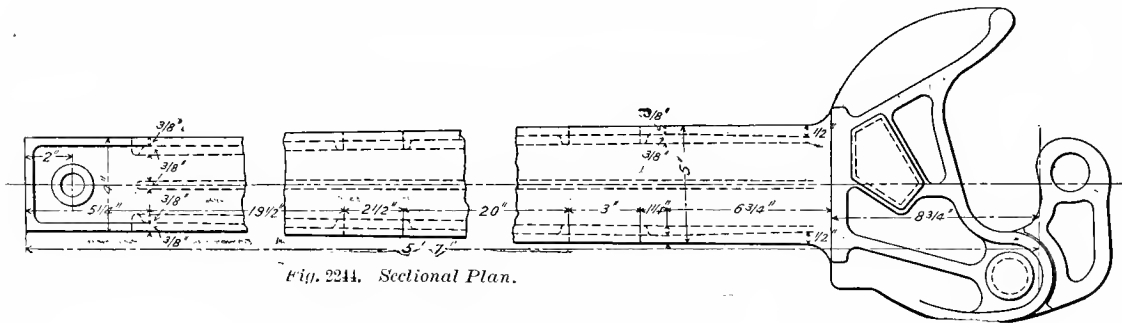

Fig. 2244. Sectional Plan.

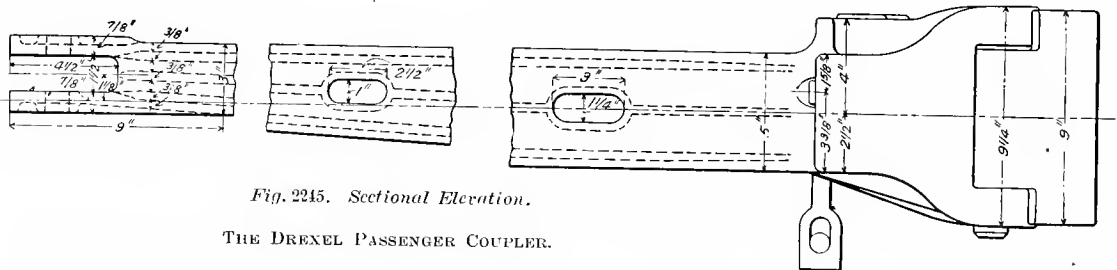

Fig. 2245. Sectional Elevation.

THE DREXEL PASSENGER COUPLER.

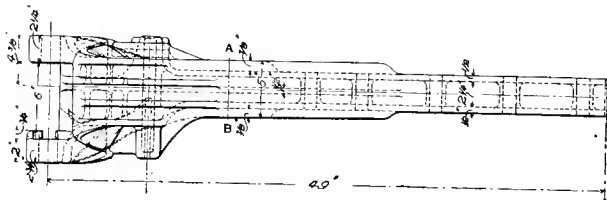

Fig. 2246. Side Elevation.

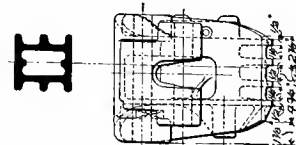

Fig. 2248. End Elevation.

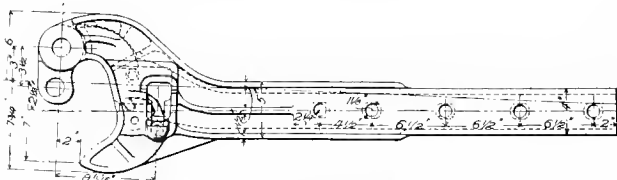
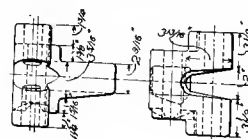

Fig. 2247. Plan.



Figs. 2250-2251. Knuckle.

THE GOULD PASSENGER DRAW-BAR AND COUPLER.

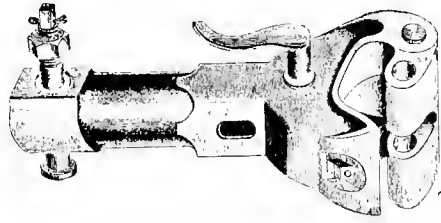

Fig. 2252. Perspective View.

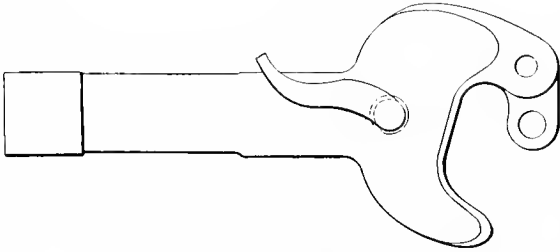

Fig. 2253. Plan.

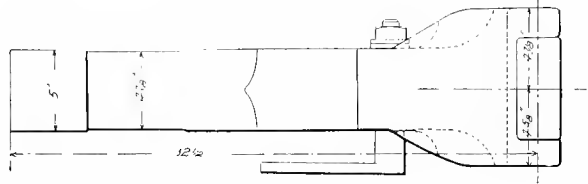

Fig. 2254. Elevation.

THE JANNEY PASSENGER COUPLER.

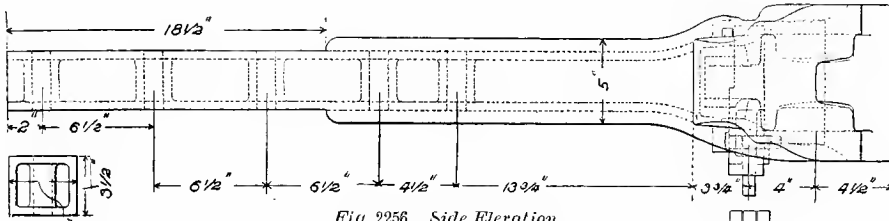

Fig. 2255. Side Elevation.

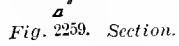

Fig. 2259. Section.

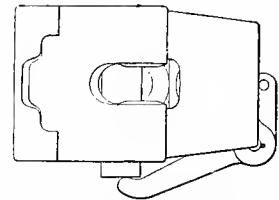

Fig. 2258. End Elevation

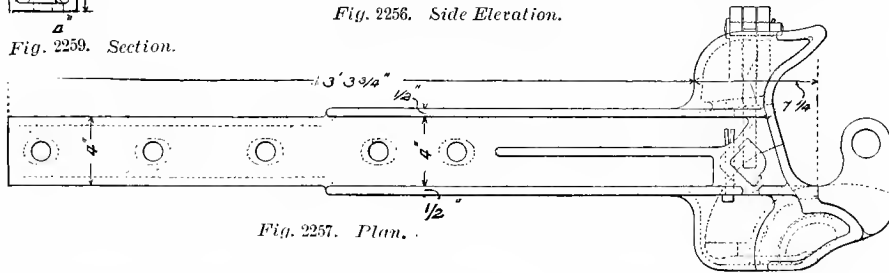
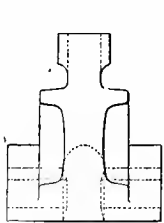

Fig. 2257. Plan.

NAMES OF PARTS.

Fig. 2267.

- 2. Knuckle.
- 6. Knuckle-pin.
- 44. Lock-spring and Bolt.
- 45. Knuckle-lock.
- 46. Lock-lever.
- 47. Lock-lever Bolt.



Figs. 2260-2261. The Knuckle.

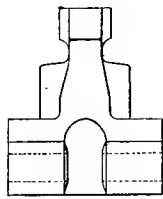
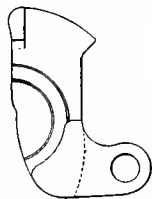
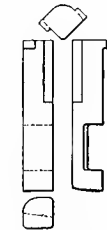

Fig. 2262. The Knuckle.



Figs. 2263-2266. The Lock.

THE IMPROVED STANDARD PASSENGER COUPLER AND PARTS.

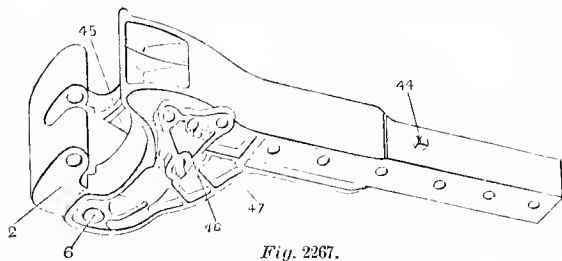

Fig. 2267. Perspective View of Underside.



Fig. 2268. Knuckle.



Fig. 2269. Knuckle Pin.



Fig. 2270. Lever Bolt.



Fig. 2271. Lock Spring and Bolt.



Fig. 2272. Passenger Operating-rod.



Fig. 2273. Lever.



Fig. 2274. Passenger Knuckle Lock.

THE TROJAN PASSENGER COUPLER AND PARTS.

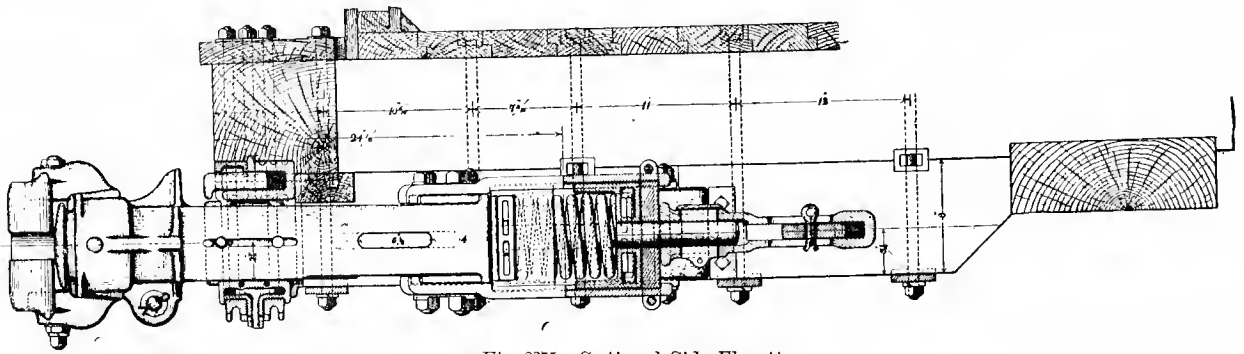

Fig. 2275. Sectional Side Elevation.

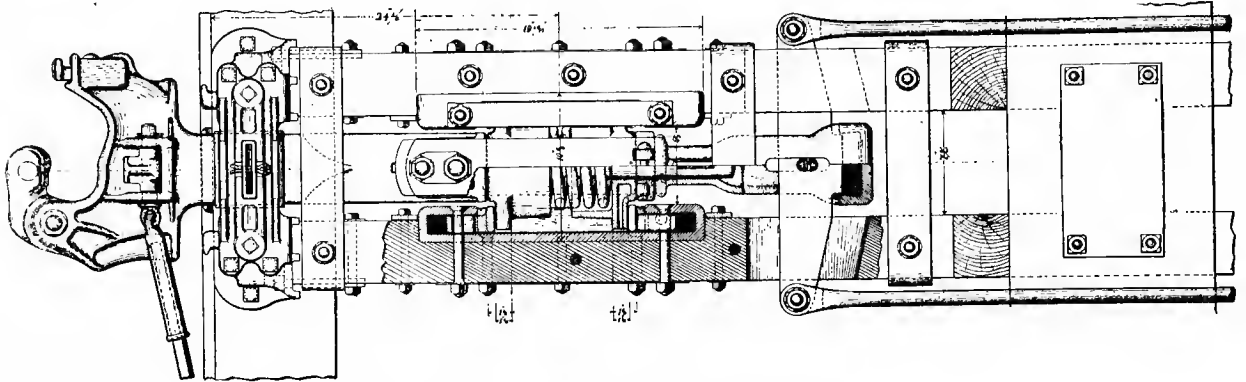

Fig. 2276. Sectional Plan.

THE VAN DORSTEN PASSENGER COUPLER AND DRAW-BAR ATTACHMENT.

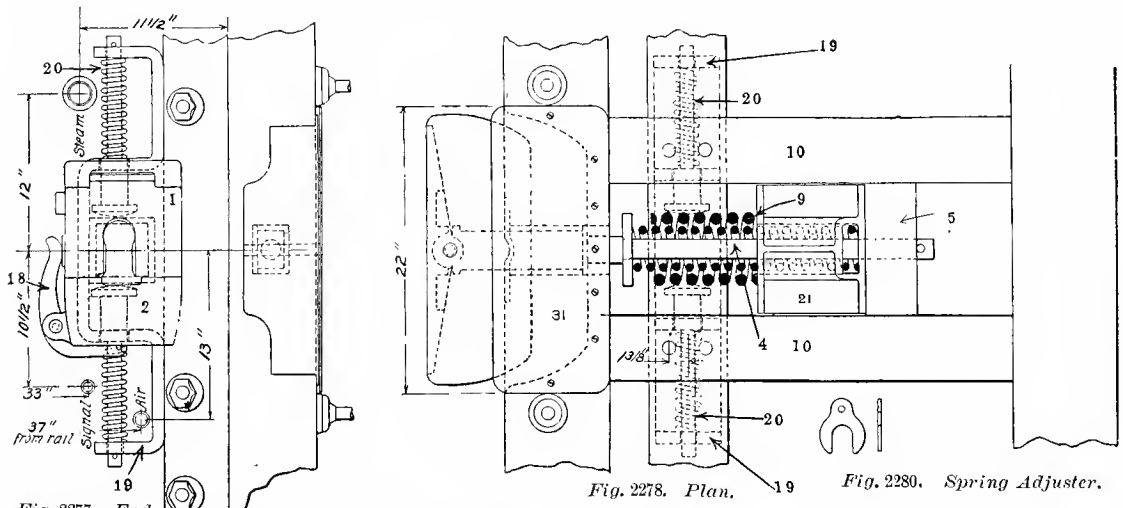

Fig. 2277. End Elevation.

Fig. 2278. Plan.

Fig. 2280. Spring Adjuster.

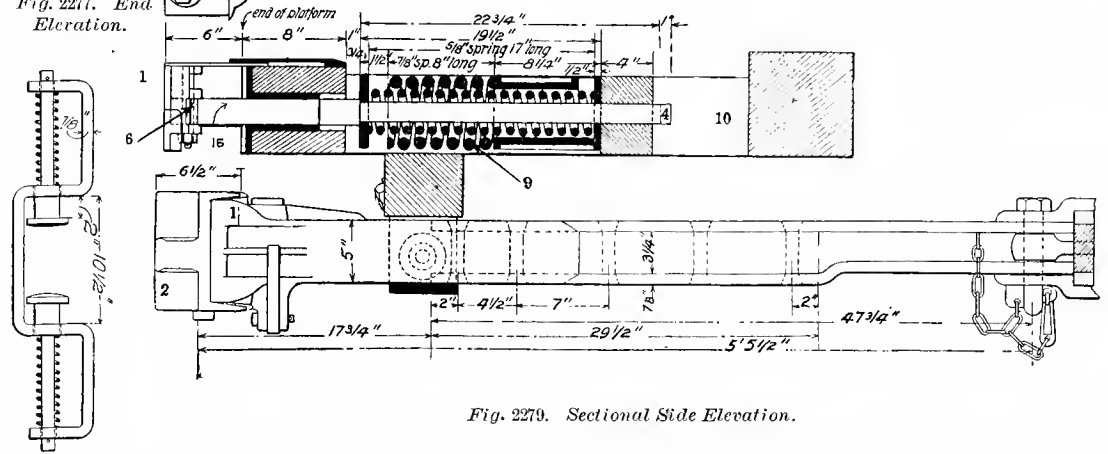

Fig. 2279. Sectional Side Elevation.

THE THURMOND-McKEEN PLATFORM AND COUPLER.

Fig. 2281. McKee Curry-iron.

Numbers refer to List of Names on Opposite Page.

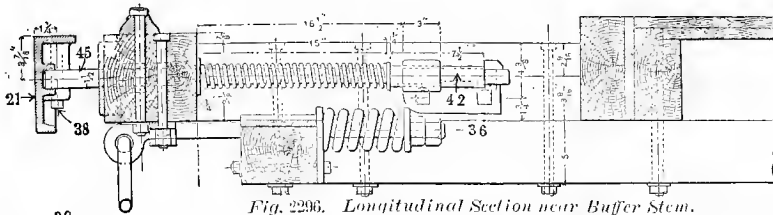

Fig. 2296. Longitudinal Section near Buffer Stem.

Fig. 2298. Cross Section.

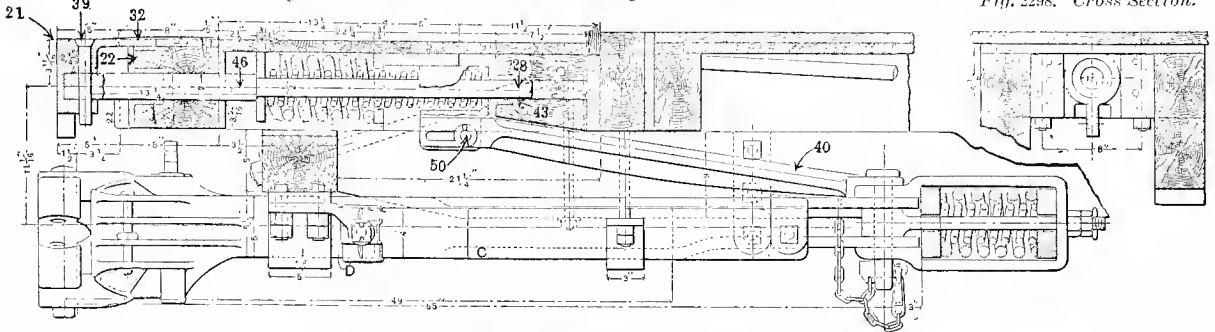

Fig. 2297. Longitudinal Section through Side Buffer-stem.

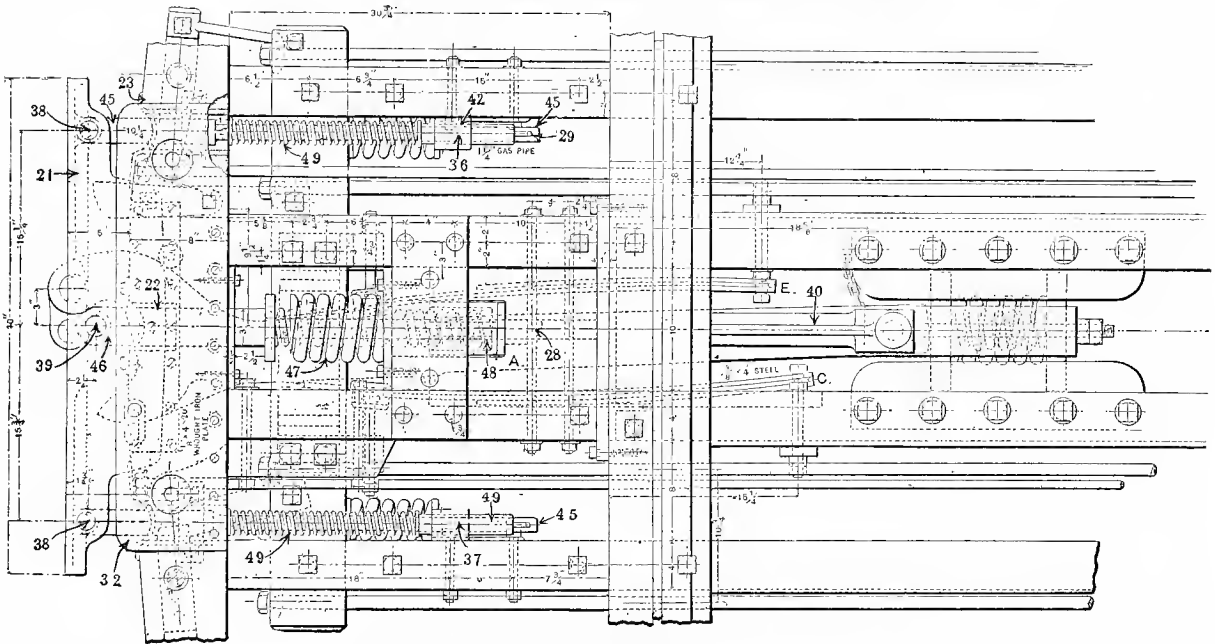

Fig. 2299. Plan of Draft Rigging.

THE GOULD CONTINUOUS PLATFORM, BUFFER AND PASSENGER COUPLER.

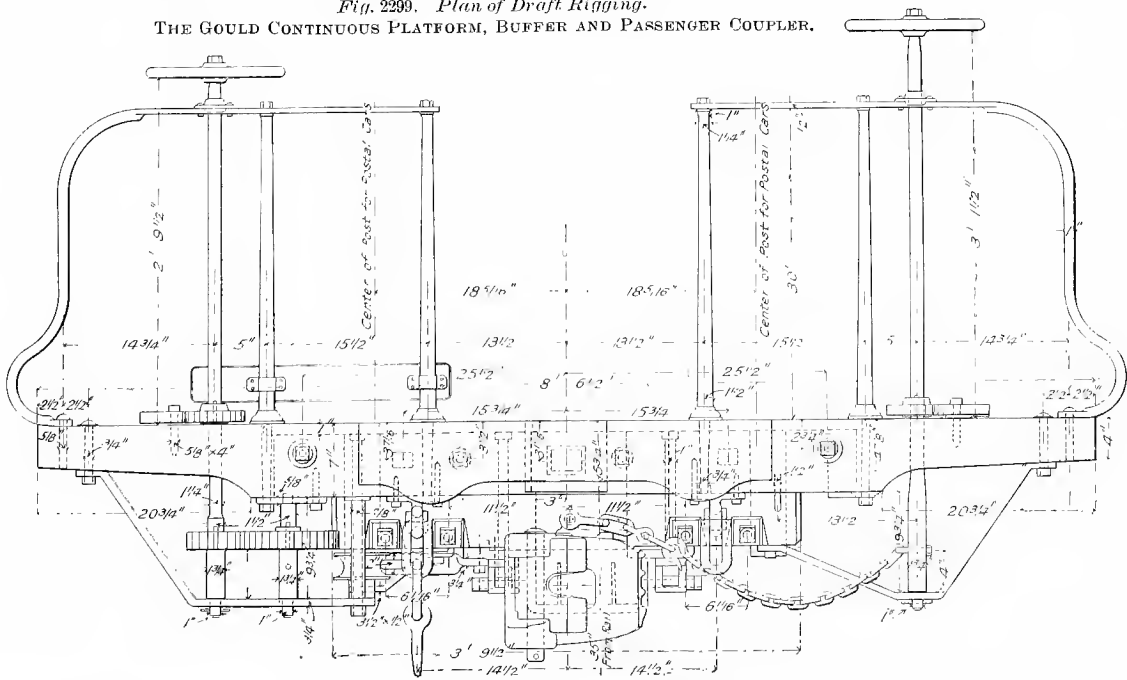

Fig. 2300. End Elevation, showing Platform and Attachment.

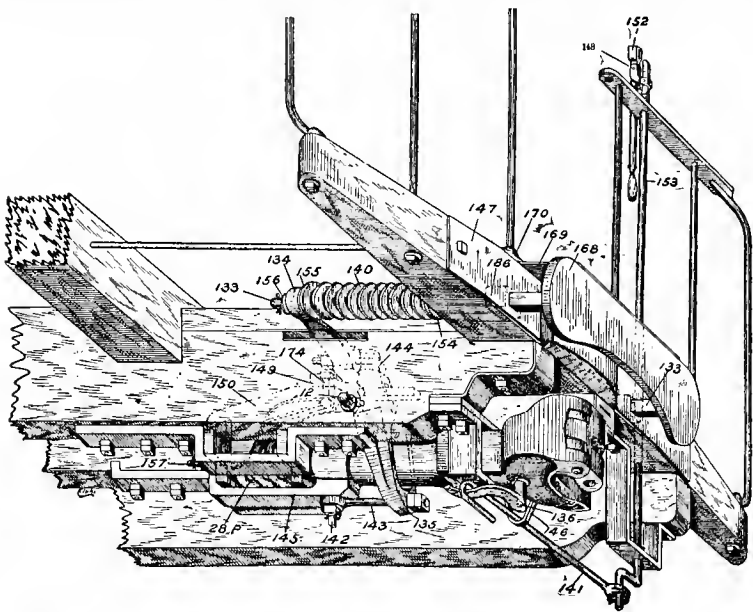
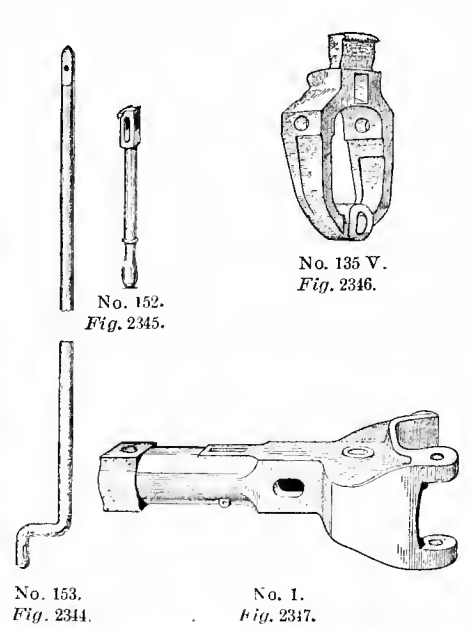
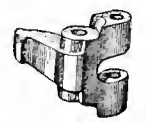
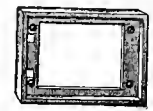

Fig. 2301. Perspective View.
THE JANNEY-BUHOUP PLATFORM EQUIPMENT.



No. 153. Fig. 2344. No. 152. Fig. 2345. No. 135 V. Fig. 2346. No. 1. Fig. 2347.



No. 147. Fig. 2312. No. 68 J-B. Fig. 2303. No. 68 1/2. Fig. 2304. No. 2. Fig. 2305.

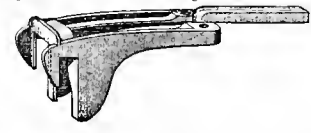
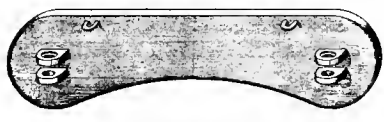

No. 138. Fig. 2306. No. 139. Fig. 2307. No. 150. Fig. 2308. No. 146. Fig. 2309.

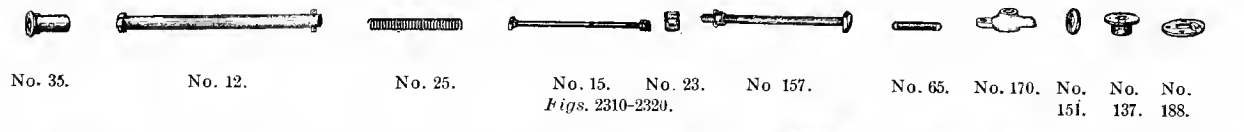

No. 35. No. 12. No. 25. No. 15. No. 23. No. 157. No. 65. No. 170. No. 151. No. 137. No. 188.

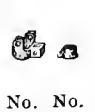
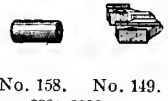
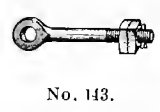
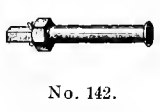

No. 140. No. 142. No. 143. No. 158. No. 149. No. 186. No. 174. No. 154. No. 155. No. 138. No. 148. No. 183.



No. 133. Fig. 2333. No. 134 V. Fig. 2334. No. 141. Fig. 2335. No. 28P. Fig. 2336.

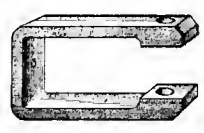
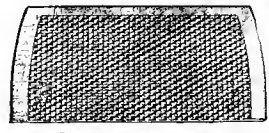

No. 169. Fig. 2337. No. 145. Fig. 2338. No. 136. No. 16. No. 212. No. 144 N. P. No. 144 O. P. Figs. 2339-2343.

NAMES OF PARTS OF JANNEY-BUHOUP EQUIPMENT. Figs. 2301-2347.

- | | | | |
|--|-----------------------------|--------------------------------|-------------------------------|
| 1. Passenger Coupler. | 133. Buffer-stem. | 145. Spring-pocket. | 157. Draft-spring Bolt. |
| 2. Knuckle. | 134v. Equalizer. | 146. Pull-rod Carrier-iron. | 158. Draft-spring Ferrule. |
| 12. Fulcrum-bolt. | 135v. Yoke-lever. | 147. Face-plate. | 168. Connected Buffer-plate. |
| 15. Catch-spring Bolt. | 136. Catch-lever. | 148. Lever-hinge Bracket. | 169. Sliding Foot-plate. |
| 16. Knuckle-pin. | 137. Catch-lever Thimble. | 149. Thrust, Top. | 170. Foot-plate Stop. |
| 23. Half Oval Washer for Catch-spring. | 138. Catch. | 150. Thrust, Bottom. | 174. Thrust-bolt. |
| 25. Catch-spring. | 139. Foot-plate Housing. | 152. Lever-handle. | 183. Uncoupling-lever Collar. |
| 28P. Main Draft-spring. | 140. Buffer-spring. | 153. Uncoupling-lever. | 186. Buffer-guide. |
| 35. Fulcrum-ferrule. | 141. Pull-rod. | 154. Buffer-stem Ring-washers. | 188. Collar-stop Socket. |
| 65. Trap-door Spring. | 142. Tail-pin. | 155. Buffer-stem Lug-washers. | 212. Coupling-pin. |
| 68JB. Trap-door, Janney-Buhoup. | 143. Yoke Connecting-bolt. | 156. Buffer-stem End-washers. | |
| 68 1/2. Trap-door Frame. | 144OP. U-bolt, Old Pattern. | | |
| | 144NP. U-bolt, New Pattern. | | |

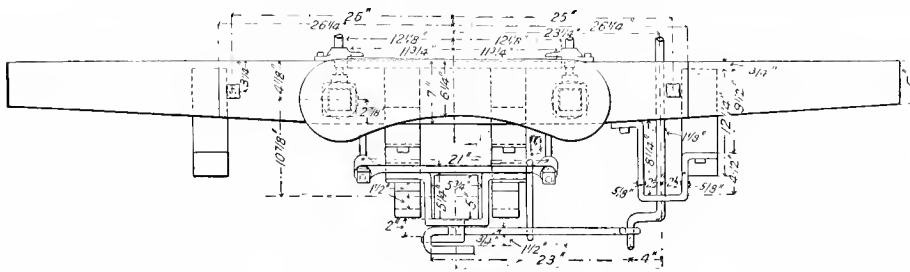

Fig. 2348. End Elevation.

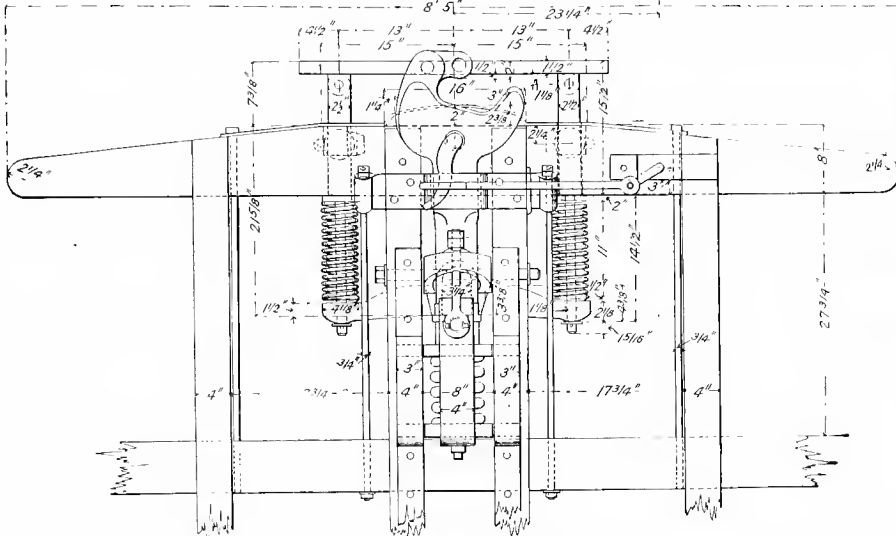

Fig. 2349. Inverted Plan.

THE JANNEY-BUHOP PLATFORM EQUIPMENT
Giving Dimensions and Sizes of Parts.

- NAMES OF PARTS.
Figs. 2351-2354.
- AA. Center Buffer-stem.
 - BB. Side Buffer-stem.
 - C. Tee Connection with Pump.
 - D. Side Buffer-stem Cylinder.
 - E. Center Buffer-stem Cylinder.
 - F. Pressure-bar Cylinder.
 - G. Side Buffer-stem Piston.
 - H. Center Buffer-stem Piston.
- (Continued.)

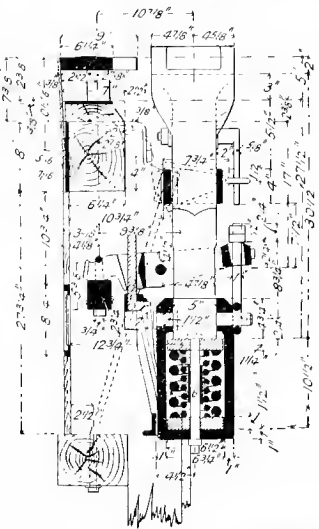

Fig. 2350. Longitudinal Section.

(Concluded.)

- J. Pressure-bar Piston.
- K. Pressure-bar.
- L. Folding-steps.
- M. Lever for Operating Folding-steps.
- N. Lever-bar.
- O. Water-pipe Connections.
- P. Buffer-plate.
- R. Center Buffering-spring.
- S. Side Buffering-spring.
- T. Draft-spring.

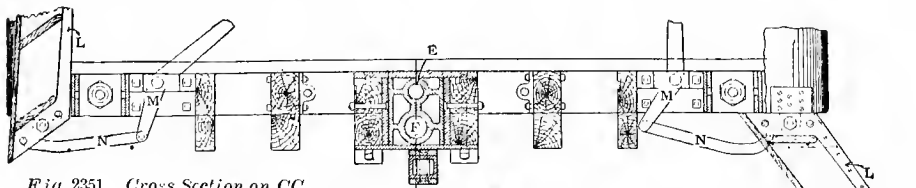

Fig. 2351. Cross Section on CC.

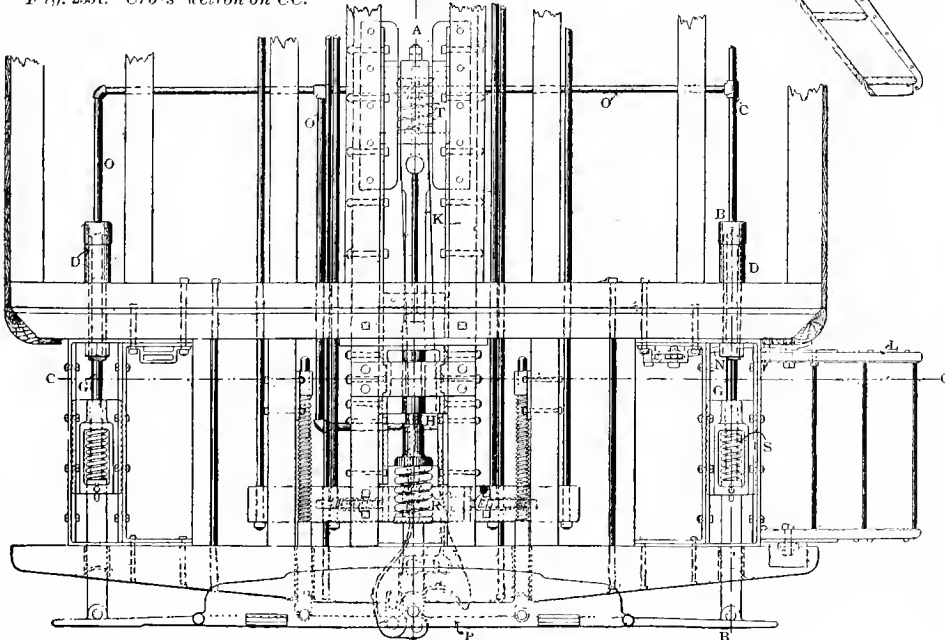

Fig. 2352. Plan.

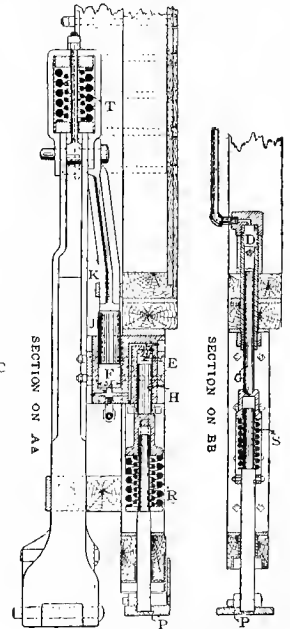

Fig. 2353. Section of Center Buffer.
Fig. 2354. Section of Side Buffer.

THE LEONARD HYDROSTATIC BUFFER.

Used on the Empire State Express, New York Central & Hudson River Railroad. Folding-steps.

CAR-FRAMING—NOTE: Details of Car Framing are shown as follows: Box Cars, Figs. 617-693; Flat Cars, Figs. 993-1001; Caboose, Fig. 1163; Baggage Cars, Figs. 1171-1243; Passenger Cars, Sides and Roof, Figs. 539-560; Private and Sleeping Cars, Figs. 565-538.

Numbers refer to List of Names on opposite page.

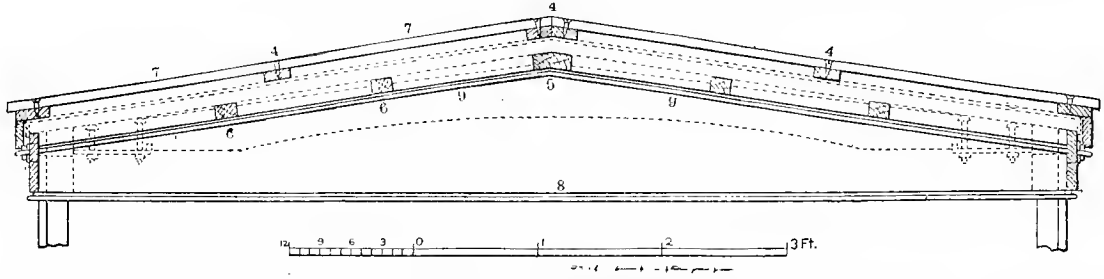

Fig. 2355. Transverse Section

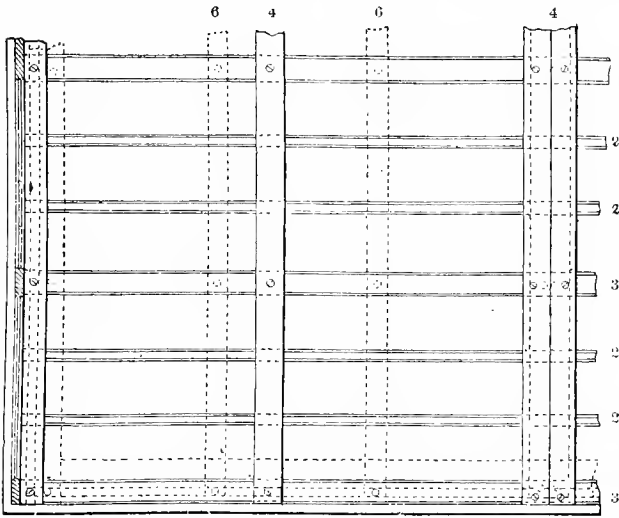

Fig. 2356. Plan.

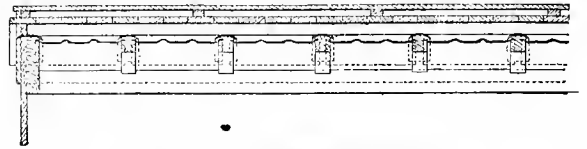

Fig. 2358. Longitudinal Section.

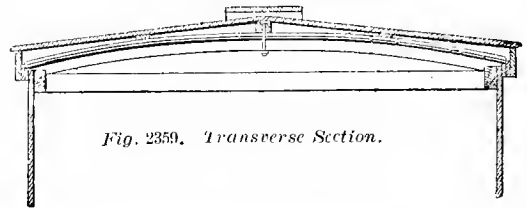

Fig. 2359. Transverse Section.

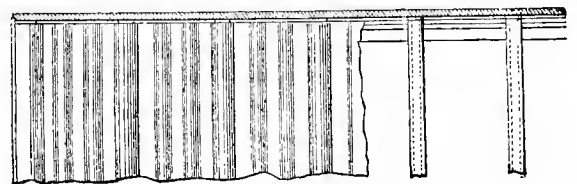

Fig. 2360. Plan.

THE WINSLOW CAR-ROOF. (With curved roof-sheets.)

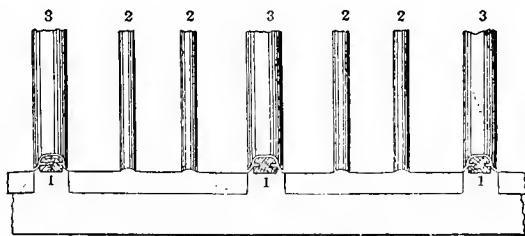

Fig. 2357. Longitudinal Section.
THE WINSLOW CAR-ROOF.

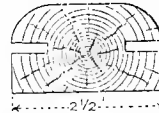

Fig. 2361.
Section of Joint Strip.

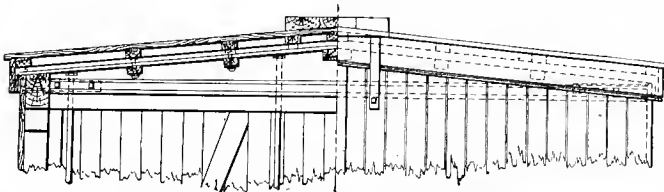

Fig. 2362.
Half Cross Section and Half Elevation.

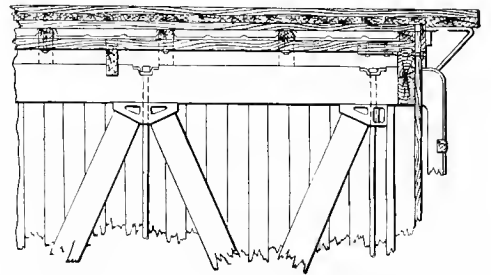

Fig. 2363. Part Longitudinal Section.

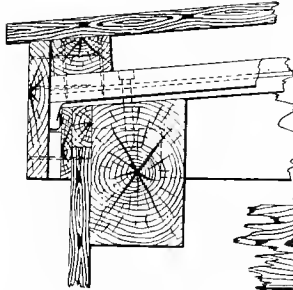

Fig. 2365.
Cross Section of Plate
and Eaves

Figs 2366-2367.
Strap Bolts for
Ridge-pole.

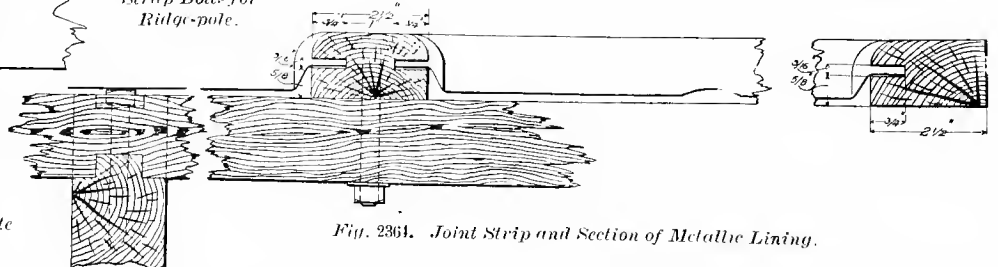

Fig. 2364. Joint Strip and Section of Metallic Lining.

WINSLOW METALLIC CAR-ROOF, AS BUILT BY THE PAIGE CAR WHEEL COMPANY.

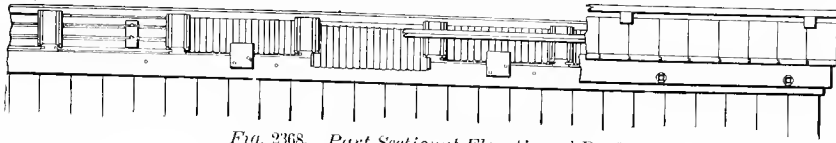

Fig. 2368. Part Sectional Elevation of Roof.

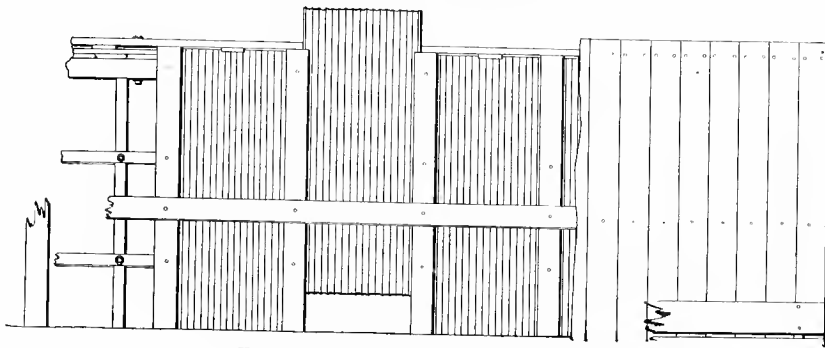

Fig. 2369. Part Sectional Plan of Roof.

NAMES OF PARTS OF WINSLOW ROOF. Figs. 2355-2361.

1. Joint-strip.
2. Corrugations.
3. Cover-strip.
4. Roof-strips.
5. Ridge-pole.
6. Purlins.
7. Roof-boards.
8. Eaves Fascia-board.
9. Carline.

NAMES OF PARTS OF THE EXCELSIOR ROOF.

Figs. 2380-2384.

- A. Lower Ridge-pole.
- B. Upper Ridge-pole.
- C. Carline.
- D. Running-boards.
- E. Roof-strips.
- F. Eaves Fascia-board.
- G. Sub-fascia-board.
- K. Galvanized Iron Lining.
- L. Furlins.
- P. Plate.
- R. Roof-board.
- S. Sub-rafter.
- T. Cover strip for Sub-rafter.

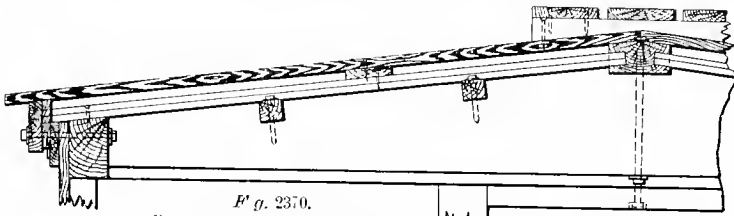

Fig. 2370. Part Cross-section of Roof.

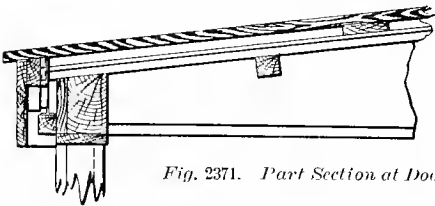

Fig. 2371. Part Section at Door.

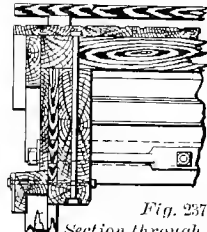

Fig. 2372. Section through End-plate.

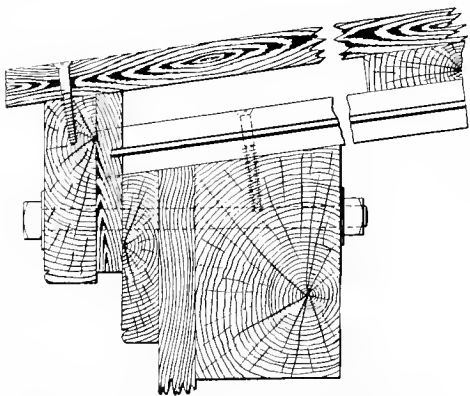

Fig. 2373. Cross Section through Plate and Eaves.

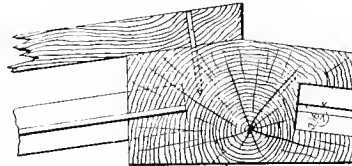

Fig. 2374. Cross Section of Ridge-pole.

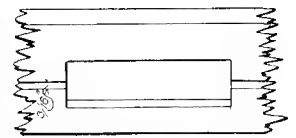

Fig. 2375. Part Side Elevation of Ridge-pole, showing Mortise.

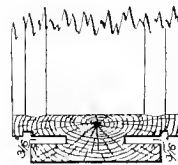

Fig. 2376. Section through Cover-strips.

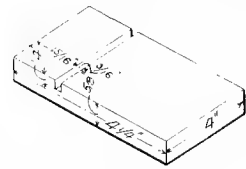

Fig. 2377. Stop block.

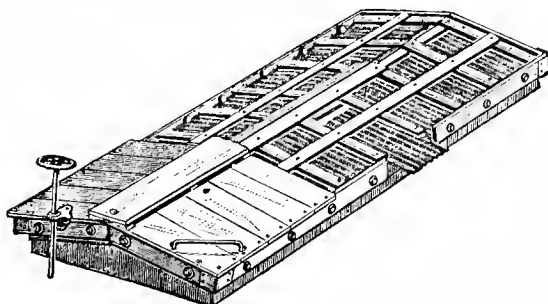

Fig. 2378. Sectional View of Roof.



Fig. 2379. Double-board Car roof.

[Letters refer to List of Names on Preceding Page.]

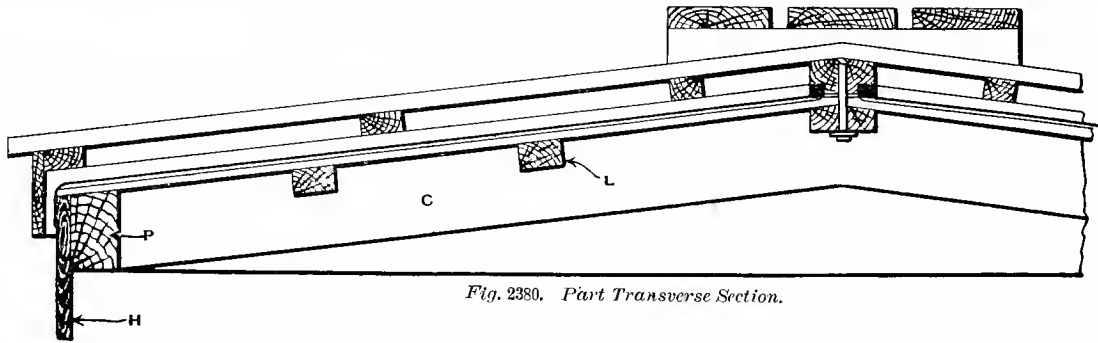

Fig. 2380. Part Transverse Section.

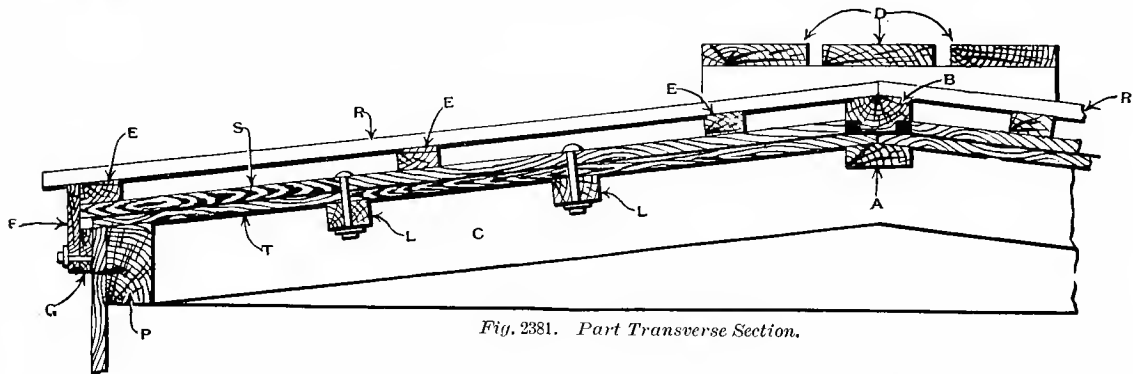

Fig. 2381. Part Transverse Section.

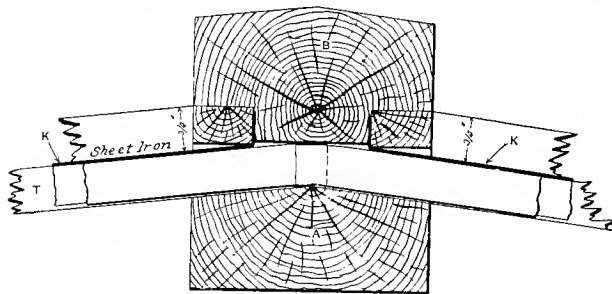

Fig. 2382. Cross Section of Ridge-pole.

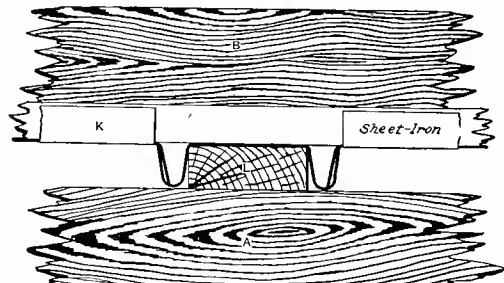

Fig. 2383. Longitudinal Section of Ridge-pole.

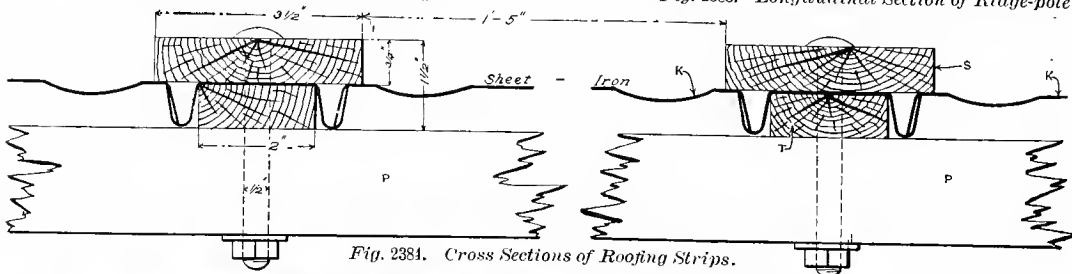

Fig. 2384. Cross Sections of Roofing Strips.

THE EXCELSIOR CAR ROOF, AN INSIDE METALLIC CAR ROOF.

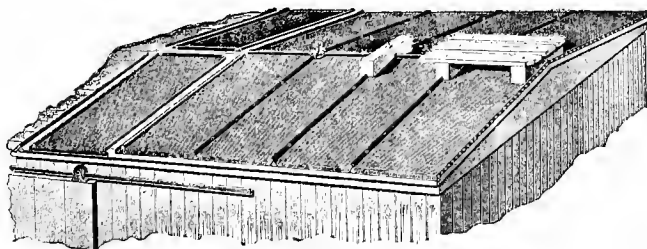

Fig. 2385. Exterior View.

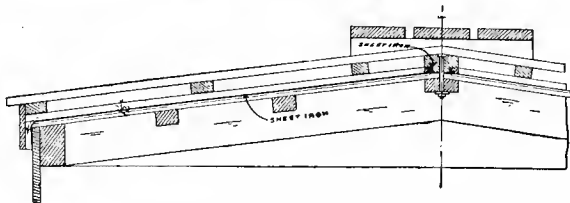

Fig. 2386. Transverse Section.



Fig. 2388. Malleable-iron Integral Corner Cap.

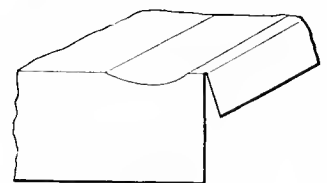

Fig. 2383a. Sheet Iron.

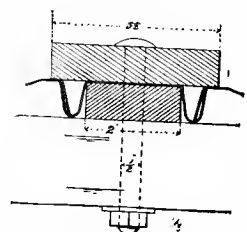
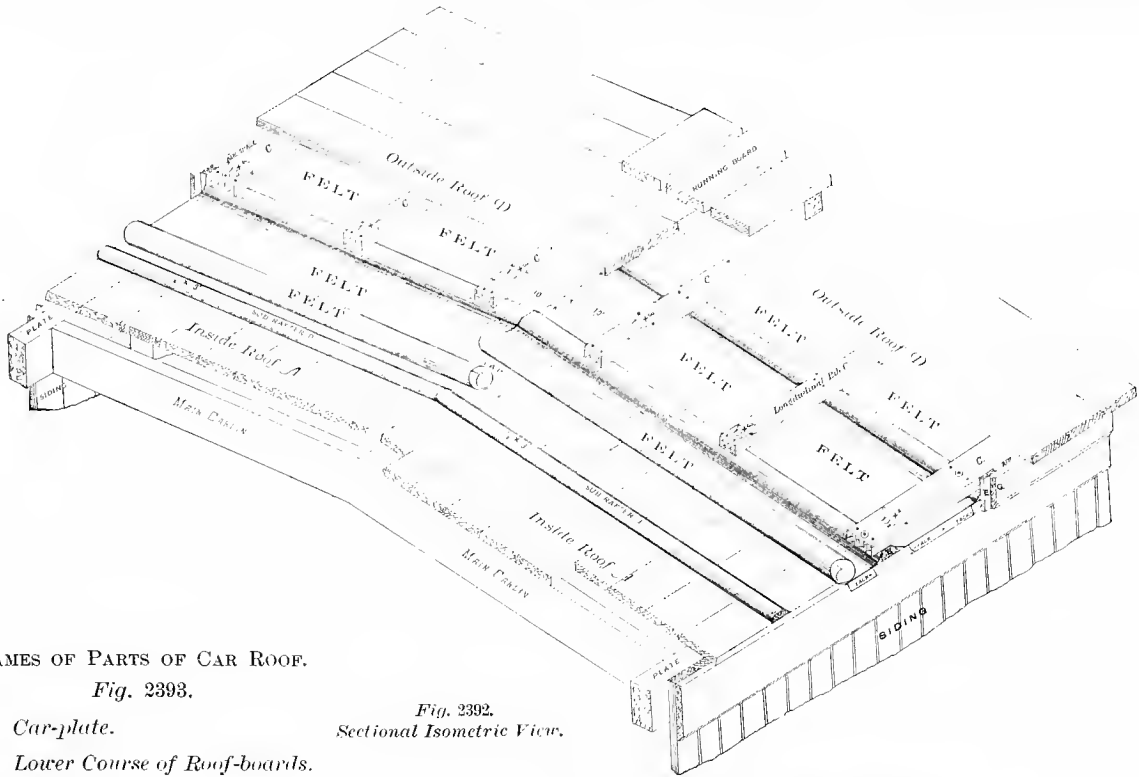

Fig. 2387. Section through Ridge-pole.

THE EXCELSIOR GALVANIZED CAR ROOF, AN OUTSIDE METALLIC CAR ROOF.
MANUFACTURED BY THE EXCELSIOR CAR ROOF COMPANY, ST. LOUIS.



NAMES OF PARTS OF CAR ROOF.

Fig. 2393.

1. Car-plate.
3. Lower Course of Roof-boards.
4. Purlins.
5. Sub-rafter, fluted.
7. Roof-boards.
8. Running-board.
9. Carline.
10. Roof-lining.
11. Fascia-board.
12. Sub-fascia Board.

Fig. 2392.
Sectional Isometric View.

CAR ROOF. THE DRAKE & WEIR COMPANY.

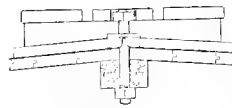

Fig. 2389.
Section through Ridge.

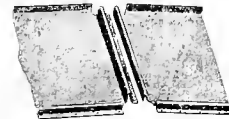

Fig. 2390.
Form of Joint.



Fig. 2391.
Section of Seam.

EXCELSIOR OUTSIDE METALLIC CAR ROOF.

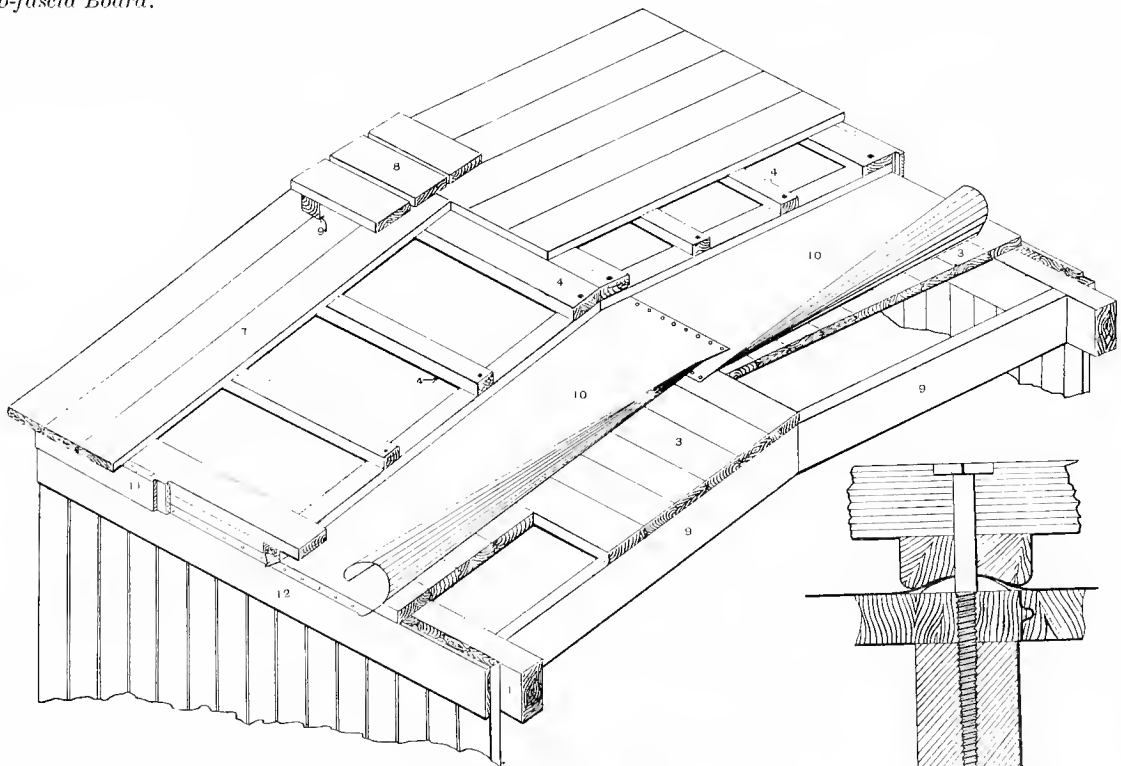

Fig. 2393. Sectional Isometric View.
NEPONSET RED ROPE CAR ROOFING. F. W. BIRD, WALPOLE, MASS.

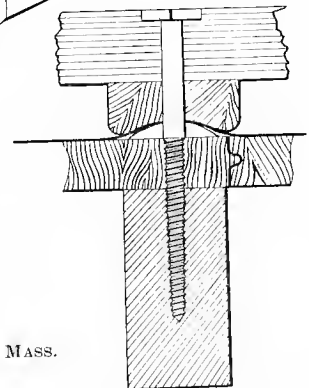

Fig. 2394. Cross-Section of Rafter.

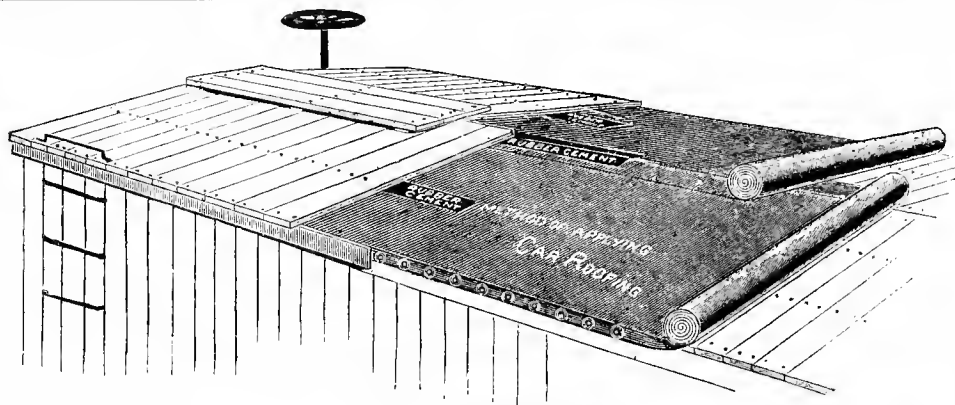

Fig. 2395. Asphalt Car Roofing.
METHOD OF APPLYING CAREY'S ASBESTOS-ASPHALT.

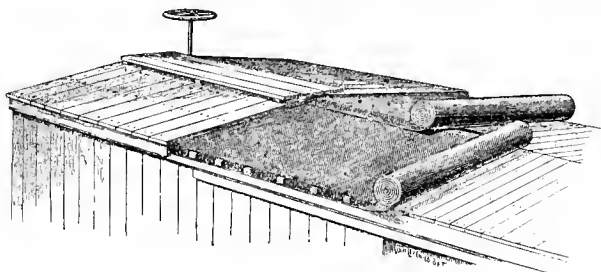

Fig. 2396. Asphalt Car Roofing.
METHOD OF APPLYING HUTCHINS' CAR-ROOF.



Fig. 2397. A roll of Roofing Material, showing how it is made up of several sheets.

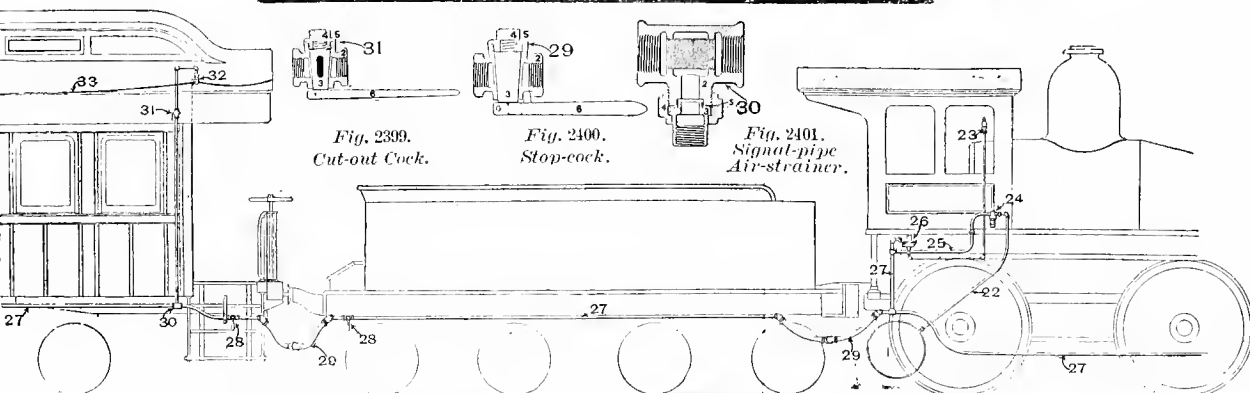

Fig. 2388. TRAIN AIR-SIGNALING APPARATUS. WESTINGHOUSE AIR BRAKE COMPANY.

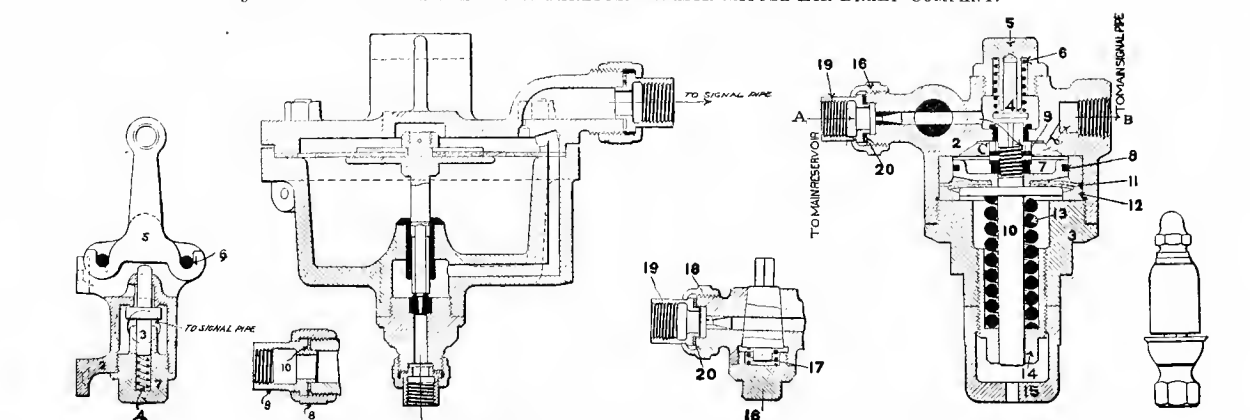

Fig. 2402. Car Discharge-valve.

Figs. 2403-2404. Signal-valve.

Figs. 2405-2406. Improved Reducing-valve.

Fig. 2407. Signal Whistle.

NAMES OF PARTS.
Figs. 2399-2400.

2. Cock-body.
3. Cock-key.
4. Cock-cap.
5. Key-spring.
6. Cock-handle.

NAMES OF PARTS. Fig. 2401.

2. Strainer-body.
3. Union-swivel.
4. Union-nut.
5. Gasket.

NAMES OF PARTS.
Figs. 2403-2404.

2. Discharge-valve Body.
3. Discharge-valve Stem.
4. Discharge-valve Spring.
5. Discharge-valve Handle.
6. Stop-pin.
7. Cap-nut.
8. Union-nut.
9. Union-swivel.
10. Union-gasket.

NAMES OF PARTS.
Figs. 2405-2406.

2. Reducing-valve Body.
3. Lower-cap.
4. Supply-valve.
5. Supply-valve Cap-nut.
6. Supply-check Spring.
7. Reducing-valve Piston (No. 8).
8. Piston Packing-ring.
9. Piston-nut.
10. Piston-rod.

NAMES OF PARTS.
Fig. 2407.

11. Diaphragm (two pieces).
12. Diaphragm-ring.
13. Adjusting-spring.
14. Adjusting-nut.
15. Cap-check Nut.
16. Cock-cap Nut.
17. Cock-spring.
18. Union-nut.
19. Union-swivel.
20. Gasket.

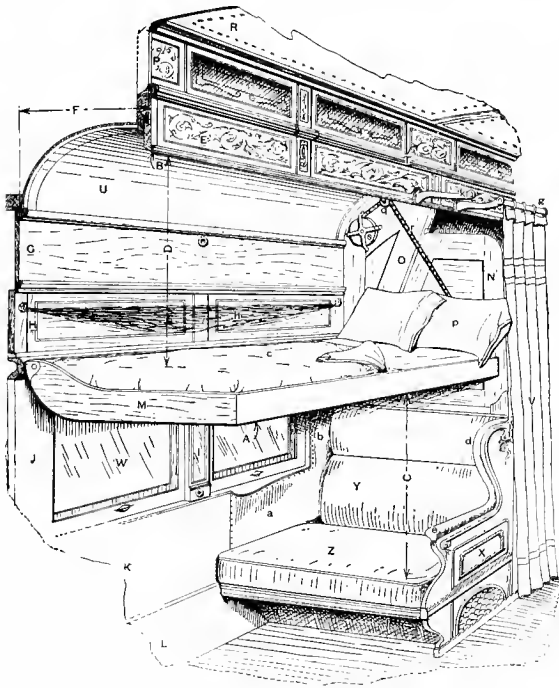

Fig. 2408. Perspective View of a Sleeping-car Section, showing Upper Berth made up.

Not the latest pattern. In later designs the corner *A* is rounded, the Bunk-apron *B* cut short, and the heights *C* and *D* increased and the distance *F* diminished, as shown in Figs. 2409-2412.

NAMES OF PARTS OF SLEEPING-CAR BERTHS.

Fig. 2408.

- | | |
|---------------------------------|-------------------------------------|
| A. Lower-berth. | U. Lower Deck-ceiling. |
| B. Bunk-apron. | V. Berth-curtain. |
| C. Head-room of Lower-berth. | W. Window. |
| D. Head-room of Upper-berth. | X. Seat-end. |
| E. Decorations of Bunk-apron. | Y. Seat-back and Berth-mattress. |
| F. Width of Lower Deck. | Z. Seat-cushion and Berth-mattress. |
| G. Inside Fascia-board. | a. Upholstering of Window Seat-end. |
| H. Bunk Window-panel. | c. Bed-clothing. |
| I. Mirror. | d. Seat-end Arm. |
| J. Inside Window-panel. | g. Curtain-rod. |
| K. Wainscot. | h. Curtain-rod Bracket. |
| L. Truss-plank. | j. Register. |
| M. Bunk-end. | n. Hammock for Clothing. |
| N. Head-board. | p. Pillows. |
| O. Bunk-partition. | q. Berth Chain-pulley. |
| P. Deck-window Panel. | r. Berth-chain. |
| R. Deck-ceiling. | s. Berth-spring. |
| T. Decorated Deck Window-panel. | |

NAMES OF PARTS OF SLEEPING-CAR SECTIONS.

Figs. 2409-2412.

1. Lower-berth.
2. Upper-berth.
3. Upper-berth (folded up).
4. Berth-front, Upper Part.
5. Berth-front, Lower Part.
6. Berth-front Panel.
7. Bunk-apron, or Deck-sill Facing.
8. Berth partition.
9. Head-board.
10. Inside Window-panel.
11. Pilaster, between Windows.
12. Wainscot.
13. Seat-end.
14. Seat-head End.
15. Curtain-rod Folding-bracket.
16. Berth Curtain-rod or Pole.
17. Berth-curtain.
18. Berth Mattresses.
19. Pillow-box.
20. Bunk-end.
21. Bunk-panel.
22. Lower-deck Ceiling.
23. Berth-spring and Frame
24. Berth Chain-pulley.
25. Berth-chain.
26. Berth Safety-rope.
27. Card or Writing-table.
28. Table-leg.

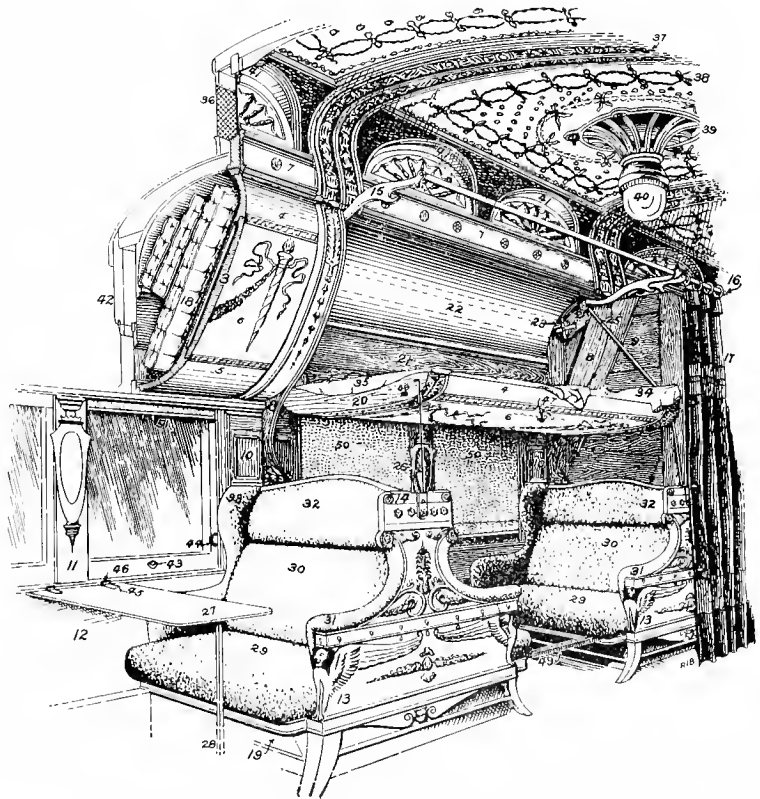

Fig. 2409. Perspective View of a Section of a Sleeping-car, the Upper Berth partly made up.

THE COLUMBIAN STYLE OF SLEEPING-CAR SECTION
PULLMAN'S PALACE CAR COMPANY.

Numbers Refer to List of Names on this and the Preceding Page.

NAMES OF PARTS.

Figs. 2409-2412.

(Continued.)

- 29. *Seat-cushion.* (The cushion pulls out, and the back takes the place of the cushion, and together they form the lower berth.)
- 30. *Seat-back.*
- 31. *Seat-arm, Upholstered.*
- 32. *Head-rest and Head-board Pocket.* (The upholstered head-rest lifts up about its hinged top and forms a pocket for day wearing-apparel.)
- 33. *Upholstered Inner Seat-end.*
- 34. *Pillow.*
- 35. *Blankets.*
- 36. *Deck-window Screen.*
- 37. *Vaulted Compound-car-line Decorations.*
(Continued.)



Fig. 2410. Perspective View of a Section of a Sleeping-car, arranged for day travel.

NAMES OF PARTS.

Figs. 2409-2412.

(Concluded.)

- 38. *Vaulted Deck-ceiling.*
- 39. *Lamp-dome.*
- 40. *Center-lamp.*
- 41. *Vaulted Deck-window.*
- 42. *Cross-Section of Car-side.*
- 43. *Window Sash-lift.*
- 44. *Window-stop.*
- 45. *Table-hook.*
- 46. *Table-hook Plate.*
- 47. *Berth-catch Handle.*
- 48. *Berth-catch.*
- 49. *Lower-berth Stop-bar.*
- 50. *Window-shade.*
- 51. *Window-shade Thumb-latch.*
- 52. *Hammock.*
- 53. *Seat-back Paneling.*
- 54. *Head-board Bolt and Lock.*
- 55. *Hat-posts.*

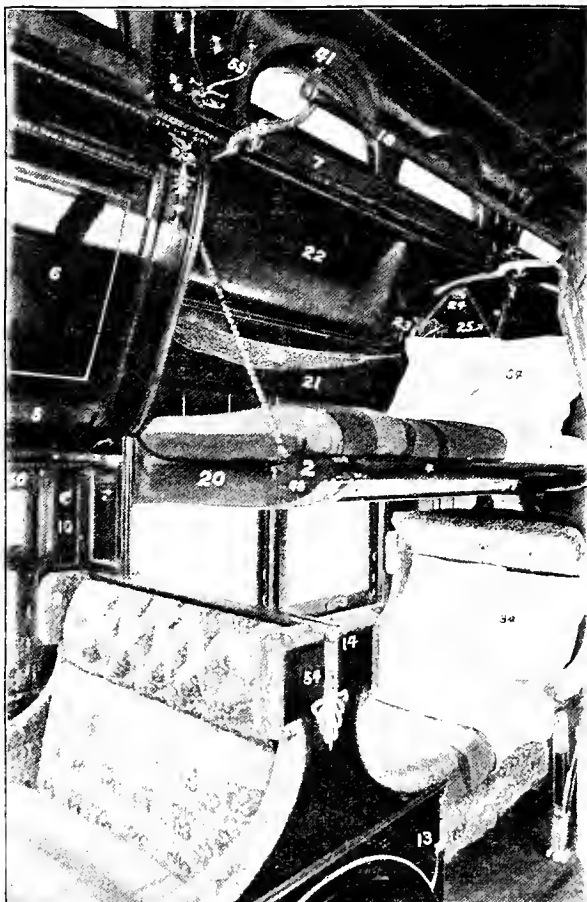

Fig. 2411. Perspective View of a Section of a Sleeping-car, with the Upper and Lower Berths made up, except the Head-board and Curtains.

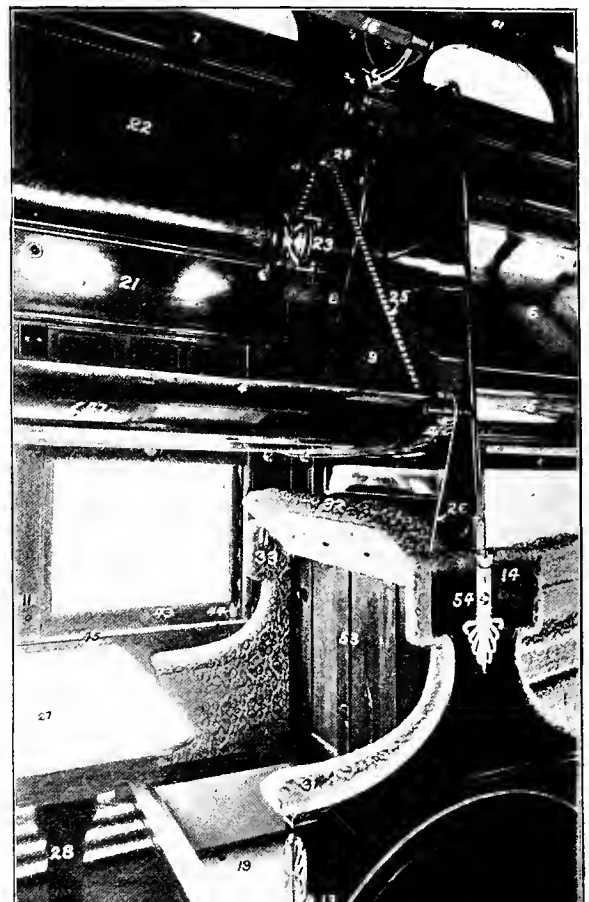

Fig. 2412. Part Perspective View of a Section of a Sleeping-car, with Cushions removed and showing Pillow-box, Upper-berth Hangings, Head-board and Table.

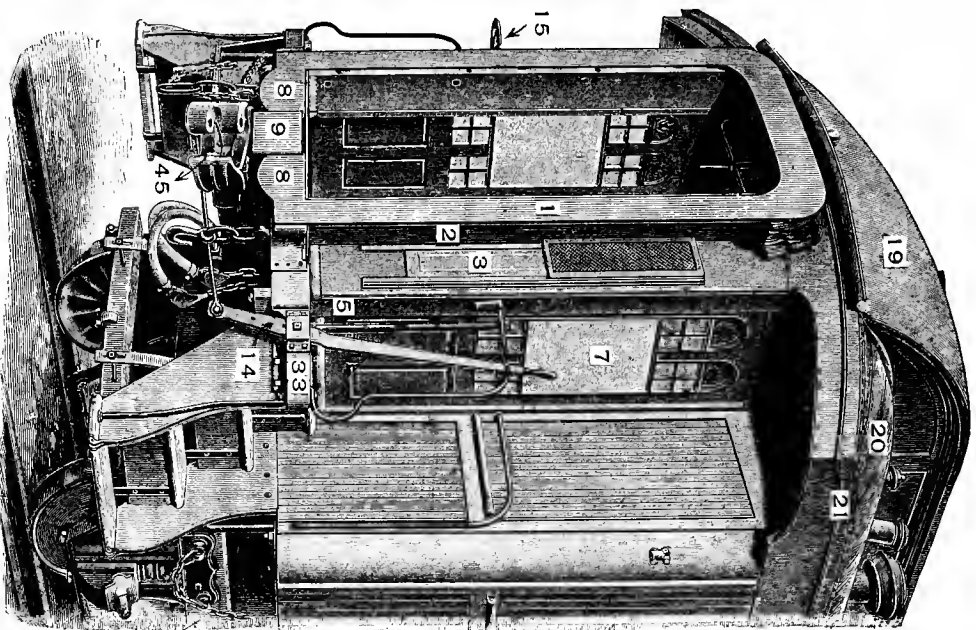

Fig. 2419, *Perspective View.*
THE BARR WING-VESTIBULE AS APPLIED TO A FIRST-CLASS COACH.

- NAMES OF PARTS OF BARR VESTIBULES.
Fig. 2419.
1. Diaphragm Face-plate.
 2. Diaphragm or Outer Wing.
 3. Inner Wings.
 5. End Post.
 7. Vestibule Door.
 8. Face-plate Buffers.
 9. Main-center Buffer.
 14. Uncoupling Lever.
 15. Hand-brake Mast and Wheel.
 19. Vestibule Hoop.
 20. Platform Hoop.
 21. Letter Board.
 33. Platform End-sill.
 45. Drawbar and Coupler.

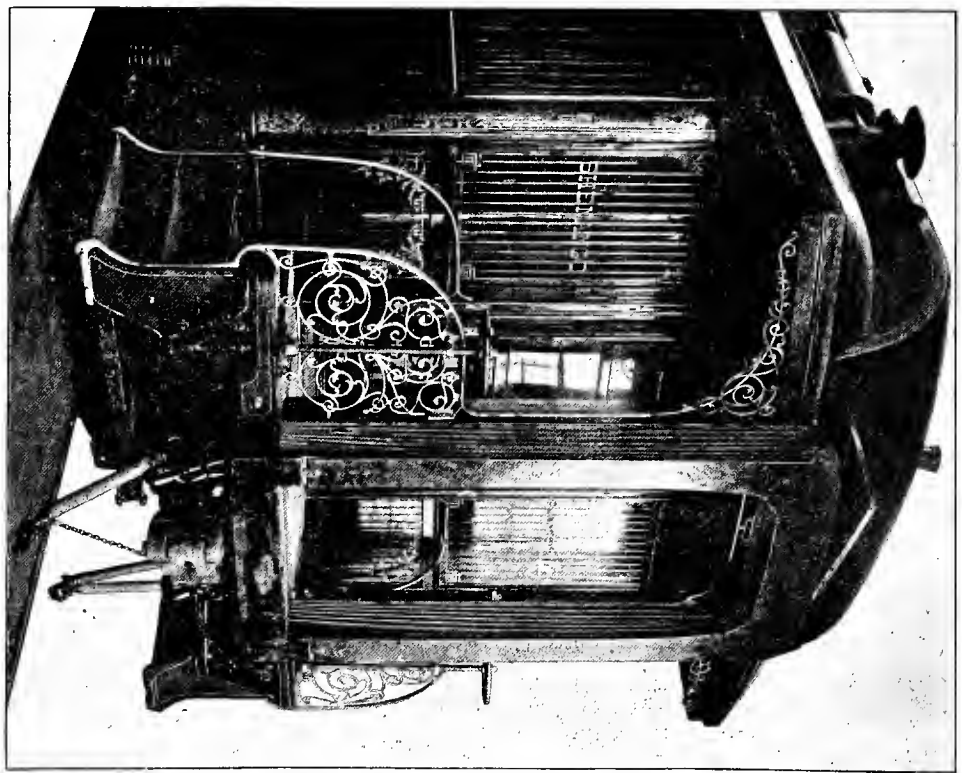

Fig. 2420, *Perspective View.*
THE GOULD VESTIBULE AS APPLIED TO A WAGNER SLEEPING-CAR.

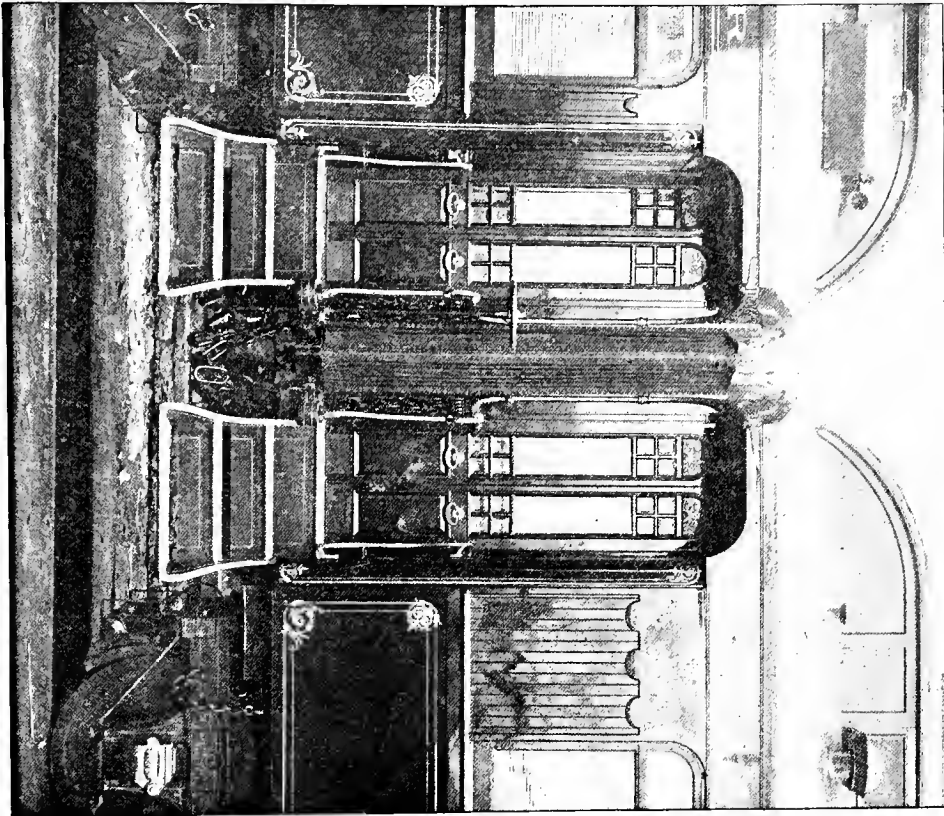

Fig. 2421. Side View.

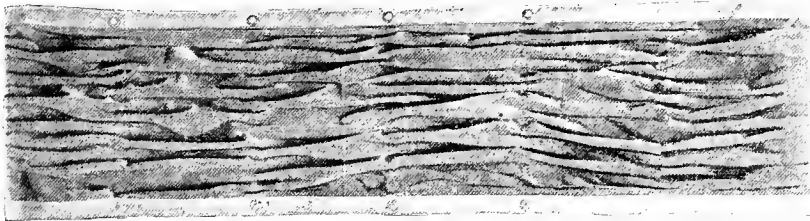

Fig. 2422a. Side View of Diaphragm, between Outer and Inner Face-plates.

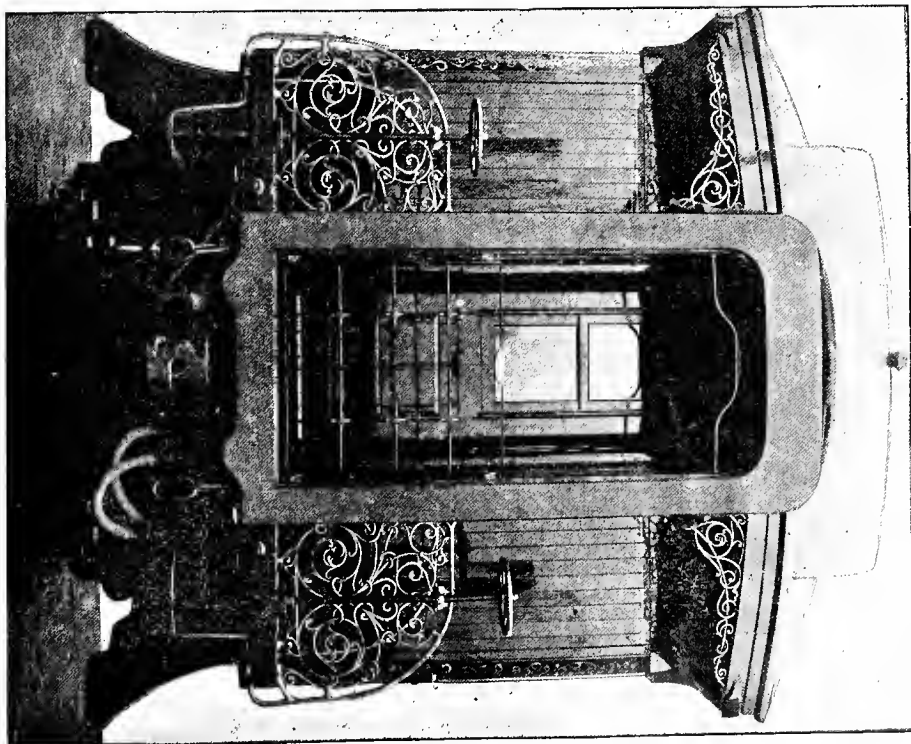

Fig. 2422. End View.

THE GOULD VESTIBULE, AS APPLIED TO PARLOR, PRIVATE AND SLEEPING CARS.

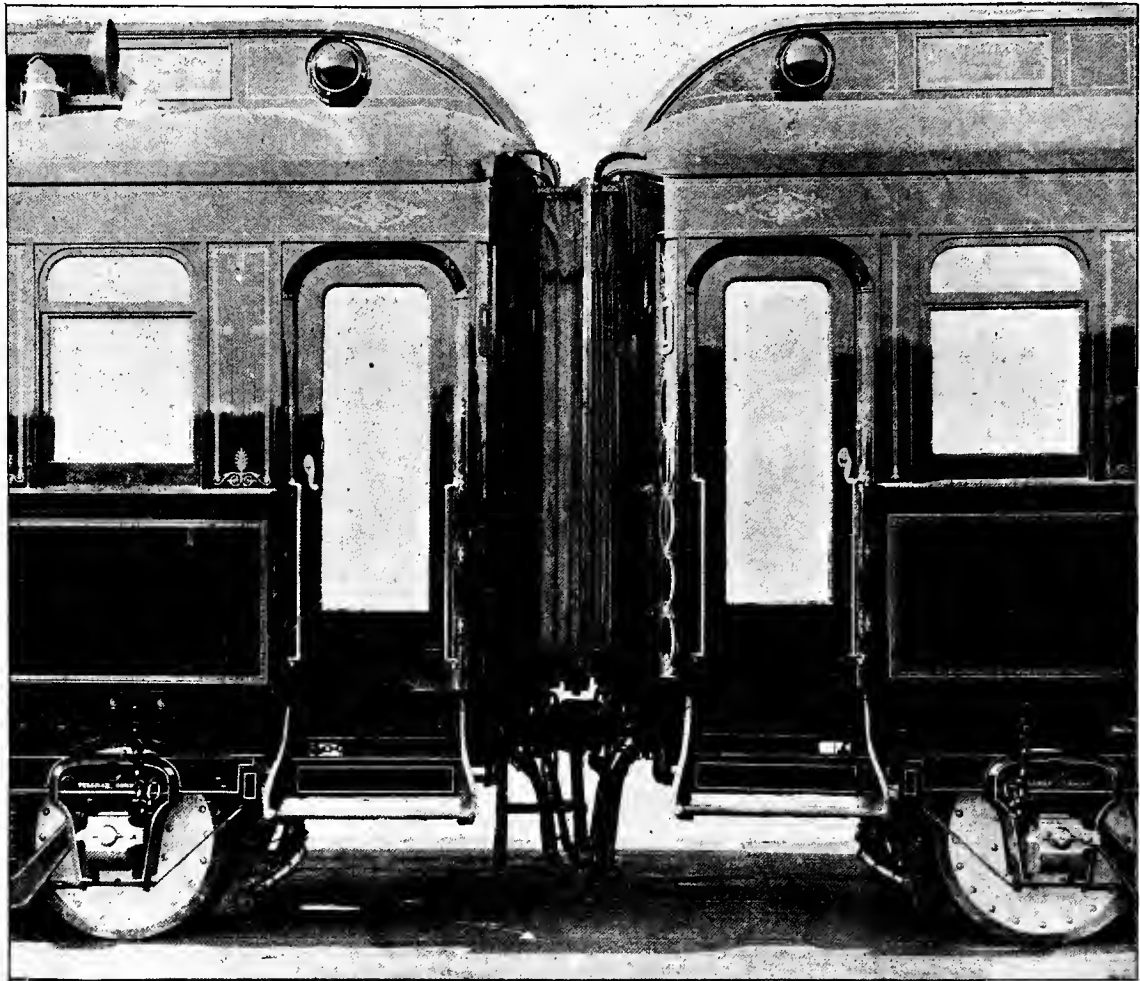

Fig. 2424. THE PULLMAN IMPROVED EXTENDED VESTIBULE, AS APPLIED TO PARLOR, PRIVATE AND SLEEPING CARS. The platform is entirely enclosed, the area over the steps being closed by a trap door.



Fig. 2423. Side View.
THE PULLMAN VESTIBULE FOR A LOCOMOTIVE TENDER.
(Exhibited at the World's Columbian Exposition, 1893, but not in general use.)

NAMES OF PARTS OF VESTIBULES. Figs. 2425-2446.

- | | | | |
|---|---|---------------------------------------|--|
| 1. Diaphragm Face-plate. | 14. Uncoupling-lever, or Mast. | 27. Horizontal Equalizing-lever. | 42. Roller for Top of Front Gravity-bar. |
| 2. Diaphragm, or Outer-wing (Barr). | 15. Hand-brake Mast and Wheel. | 28. Vertical Lever-clevis (Pullman). | 43. Bottom Face-plate Guide. |
| 3. Inner-wings (Barr). | 16. Brake-mast Gear-wheels or Sheave (Gould). | 28a. Back Gravity-bar (Gould). | 44. Roller-thimble, Front Gravity-bar. |
| 4. Inner Face-plate, or Middle-post for Vestibule. | 17. Brake-chain Guide-casting. | 29. Face-plate Piston-guide. | 45. Drawbar and Coupler (Pullman) or Thresh-old-plate (Gould). |
| 5. End-post, or Door-jamb (Pullman). | 18. Vestibule-gate Pockets (Pullman). | 30. Toggle-joint and Bar (Barr). | 46. Drawbar-spring (Pullman). |
| 6. Corner-post. | 19. Vestibule-hood. | 32. Body End-plate. | 47. Drawbar-stirrup (Pullman). |
| 7. Vestibule-door. | 20. Platform-hood. | 33. Platform End-sill (35 in Gould). | 48. Combination Yoke (Pullman). |
| 8. Face Plate-buffers, or Vestibule-buffer (Pullman). | 21. Letter-board. | 34. Buhoup Vestibule-equalizer. | 49. Drawbar-horns (Pullman). |
| 9. Platform-buffer, or Main Center-buffer (Barr). | 22. Vestibule-dome Lamp. | 35. Vestibule-end Carline. | 50. Buffer-springs (Pullman). |
| 10. Platform Foot-plate or Threshold-plate (45 in Gould). | 23. Overhead Equalizer-spring. | 36. Chain-sheave Bracket (Gould). | 51. Equalizer. |
| 11. Vestibule End-windows. | 24. Face-plate Piston. | 37. Chain-sheave (Gould). | 52. Buffer stem. |
| 12. Door Guard-rod. | 25. Vertical Equalizing-lever. | 38. Top Face-plate Guide. | 53. Bracket for Brake-gear |
| 13. Angle-plate (Barr). | 26. Equalizer Connecting-chain (Pullman) or Face-plate Retaining-chain (Gould). | 40. Gravity-bar Fulcrum-bolt (Gould). | 54. Bracket for Step-sides. |
| | | 41. Front Face-plate Gravity-bar. | |

Numbers refer to List of Names on Preceding Page.

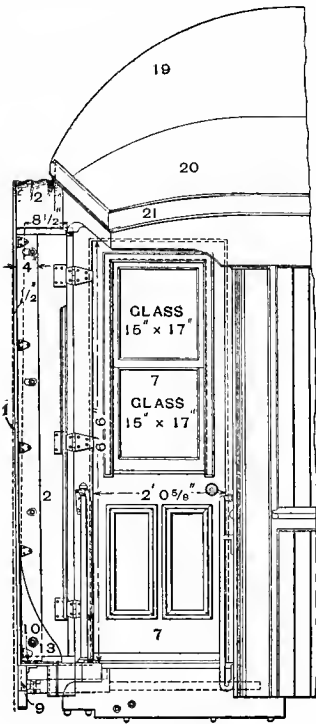

Fig. 2425. Side Elevation.

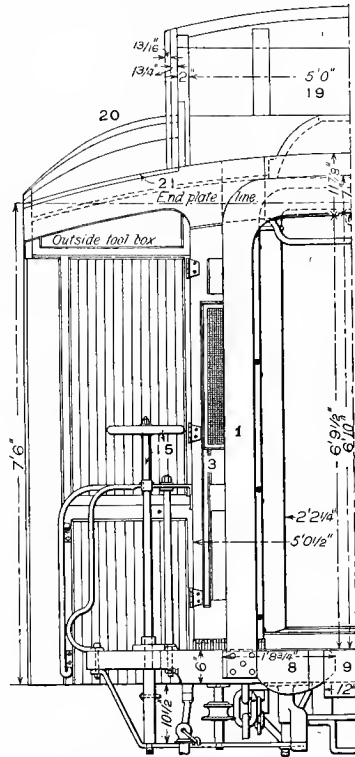

Fig. 2426. End Elevation.

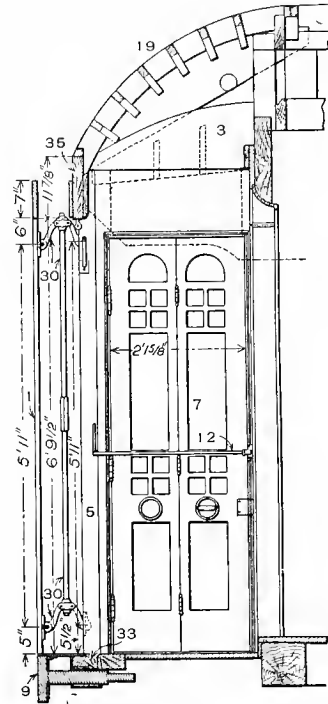

Fig. 2429. Sectional Side View.

THE BARR TOGGLE-VESTIBULE.

THE BARR IMPROVED WING VESTIBULE.
The longitudinal and lateral motions of the face-plate are permitted by hinged wings or partitions. Gravity keeps the face-plates together.

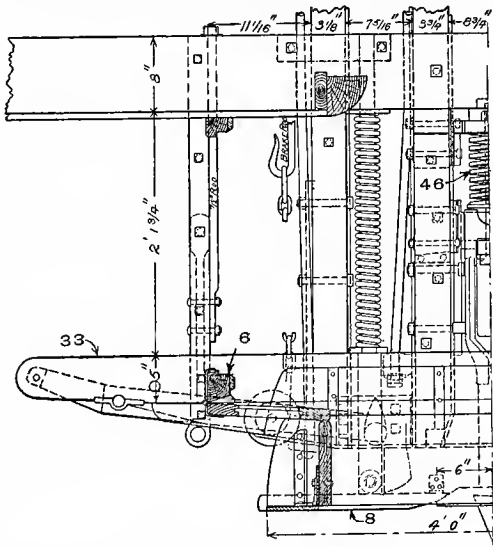

Fig. 2427. Sectional Plan.
Platform, Draft-gear and Wings of the Barr Vestibule.

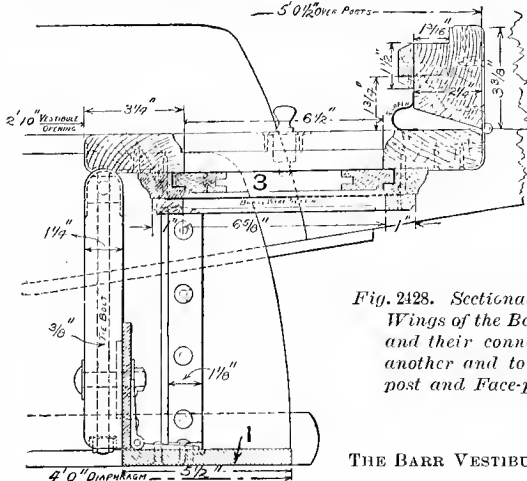

Fig. 2428. Sectional Plan of the Wings of the Barr Vestibule, and their connection to one another and to the Corner-post and Face-plate.

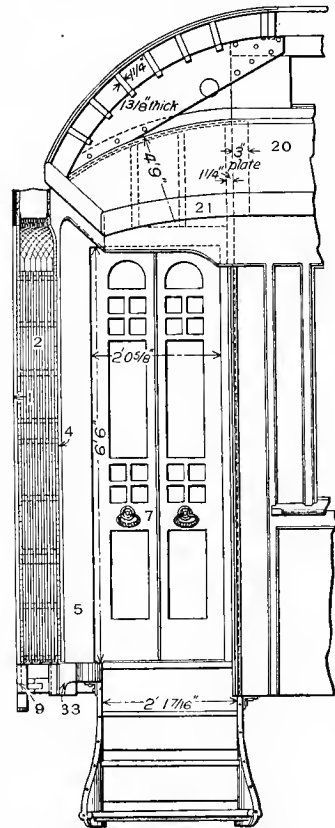

Fig. 2430. Side Elevation.

THE BARR TOGGLE-VESTIBULE.

The Face-plate is kept forced out against its opposing plate by a toggle-joint, between it and the End-post.

THE BARR VESTIBULES, MANUFACTURED BY THE DREXEL RAILWAY SUPPLY COMPANY.

Numbers Refer to List of Names on Following Page.

Fig. 2438. Plan.
THE PULLMAN EXTENDED VESTIBULE.

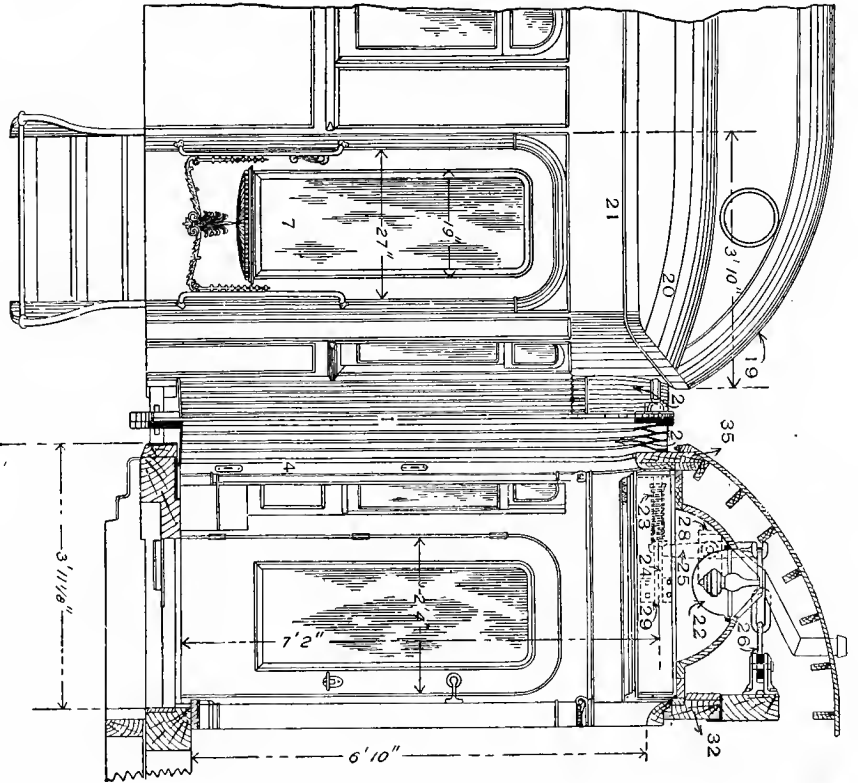
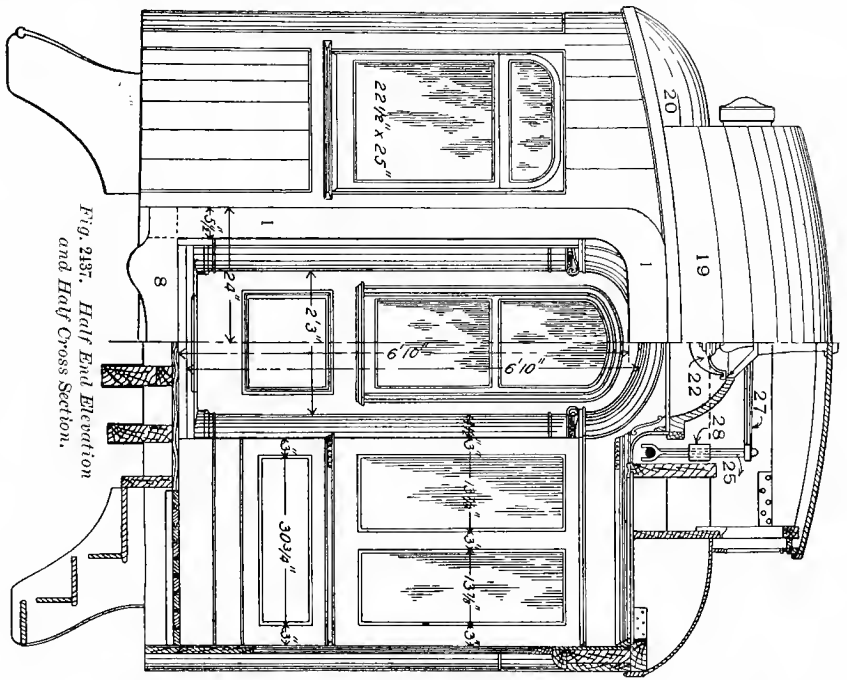
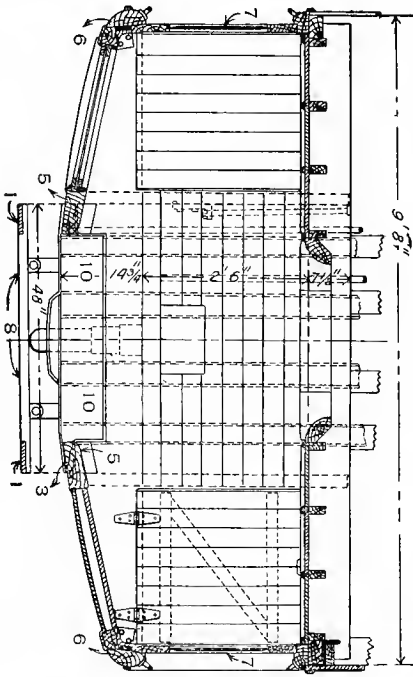

Fig. 2410. Sectional Side Elevation of Janney Bahoup Platform Attachment, as applied to Pullman Vestibule.

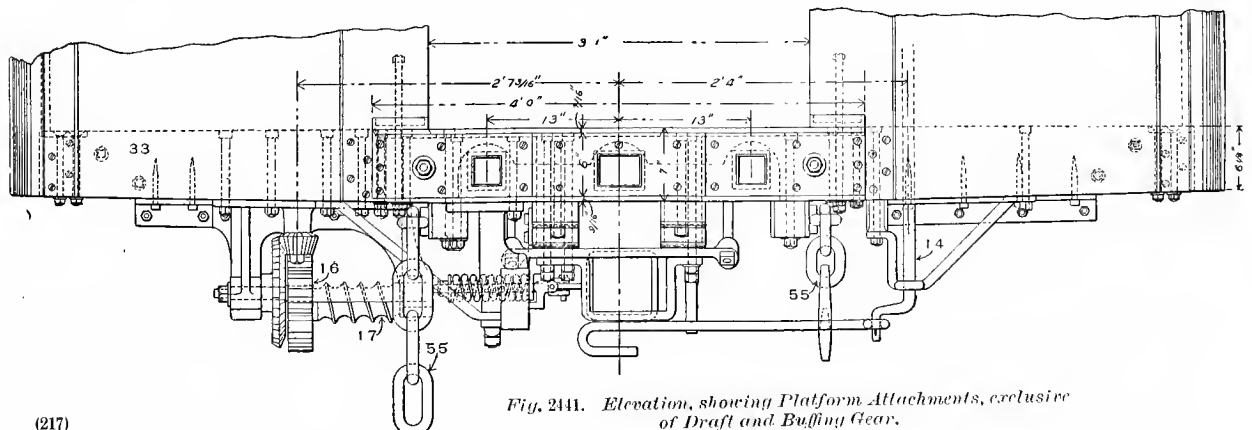
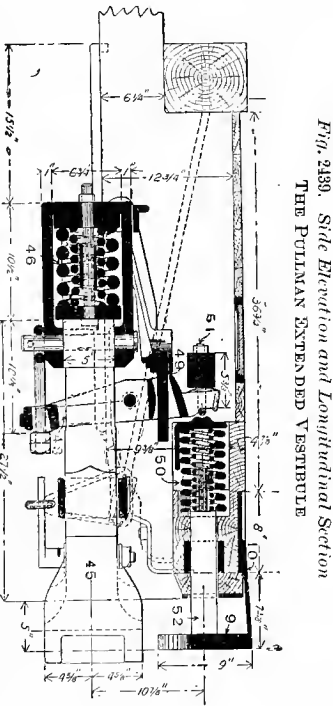

Fig. 2441. Elevation, showing Platform Attachments, exclusive of Draft and Bulling Gear.

NAMES OF PARTS OF VESTIBULES.

Fig. 2442-2245.

1. Diaphragm Face-plate.
2. Diaphragm.
4. Inner Face-plate.
5. End-post.
6. Corner-post.
7. Vestibule-door.
8. Vestibule-buffer.
10. Platform Foot-plate or Threshold-plate.
11. Vestibule End Windows.
12. Door Guard-rod.
14. Uncoupling-lever, or Mast.
15. Hand-brake Mast and Wheel.
16. Brake-mast Gear-wheels, or Sheave.
17. Brake-chain Guide-casting.
18. Vestibule-gate Pockets.
19. Vestibule-hood.
20. Platform-hood.
21. Letter-board.
22. Vestibule Dome-lamp.
23. Overhead Equalizer-spring.
24. Face-plate piston.
25. Vertical Equalizing-lever.
26. Equalizer Connecting-chain.
27. Horizontal Equalizing-lever.
28. Vertical Lever-clevis.
29. Face-plate Piston-guide.
32. Body End-plate.
33. Platform End-sill.
34. Buhoup Vestibule Equalizer.
35. Vestibule End Carline.
45. Draw-bar and Coupler.
46. Draw-bar Spring.
47. Draw-bar Stirrup.
48. Combination-yoke.
49. Draw-bar-horns.
50. Buffer-springs.
51. Equalizer.
52. Buffer-stem.
53. Bracket for Brake gear.
54. Bracket for Step-sides.

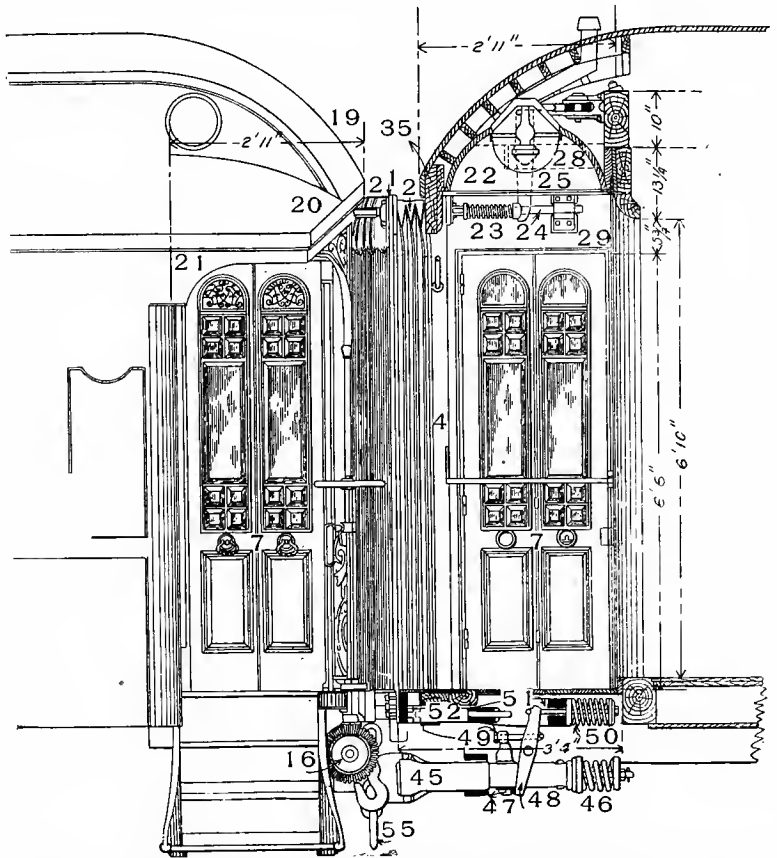

Fig. 2442. Side Elevation and Longitudinal Section, showing Equalizers and Springs for the Adjustment of Face-plates, and Hand-brake Gear.

NAMES OF PARTS OF COACH WINDOW.

Fig. 2451.

1. Truss-plank.
2. Lower Wainscot-rail.
3. Upper Wainscot-rail.
4. Wainscot-panel.
5. Inside Window-sill.
6. Window, or Window-glass.
7. Window-casing, or Inside Window-stop.
8. Window-pilaster.
9. Pilaster-cap.
10. Base of Pilaster.
11. Window-sile.
12. Window-rail, or Sash.
13. Shade.
14. Bottom-bar of Shade.
15. Window-blind Mullion.
16. Shade Thumb-latch or Lift.
17. Continuous Basket-rack.
18. Basket-rack Bracket.
19. Window-shade Stop.
20. Window-casing or Cap-molding.
21. Window-lift.
22. Window-latch.
25. Pilaster-cap Bracket.
26. Window Cove-molding.
27. Car-floor. 36. Inside Cornice.
37. Inside-cornice Sub-fascia-board, or Paneling.

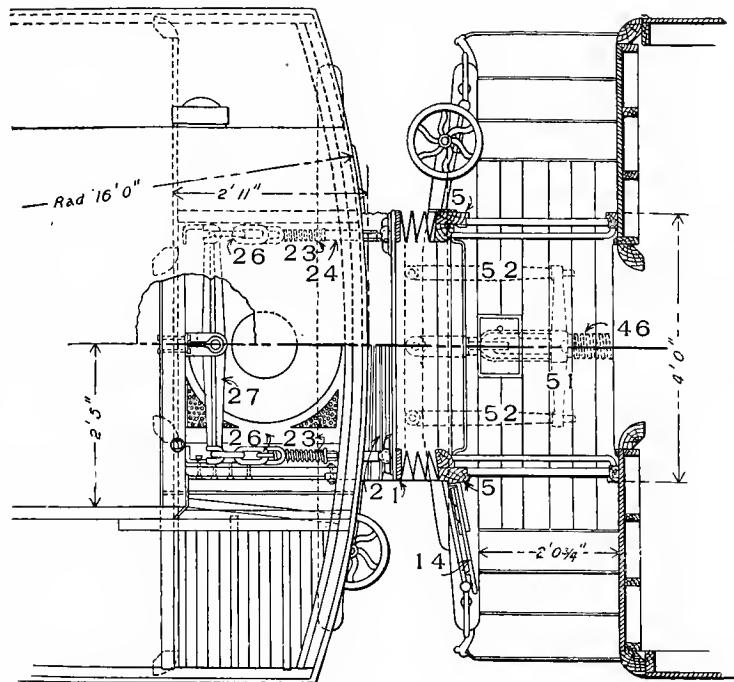

Fig. 2443. Section Plan, showing Equalizers and Springs for the Adjustment of Face-plates.

THE PULLMAN VESTIBULE (OLD PATTERN).

Numbers refer to List of Names on Opposite Page.

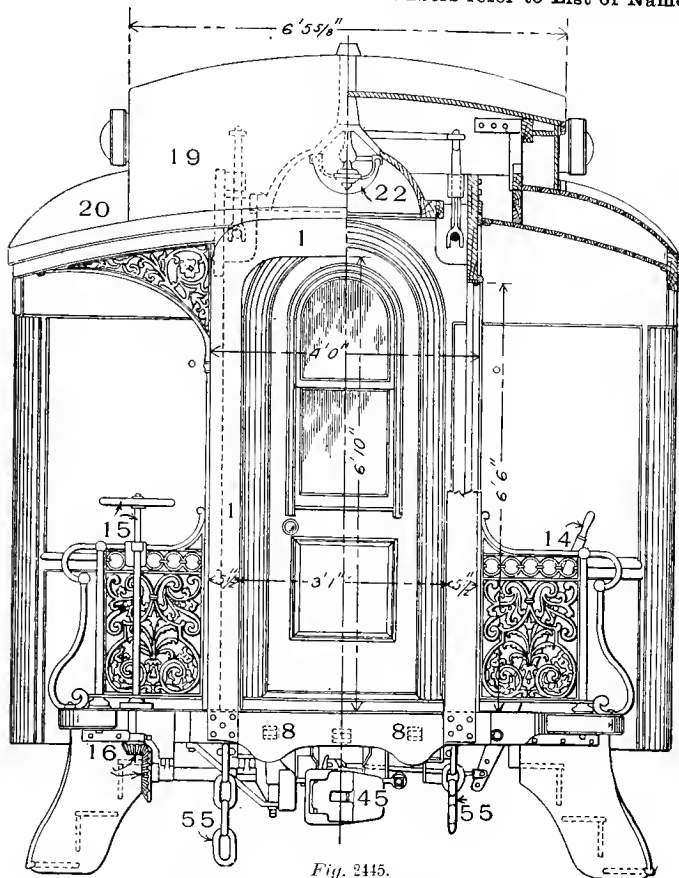

Fig. 2445.
Half End Elevation and Part Cross Section.
PULLMAN VESTIBULE (old pattern).

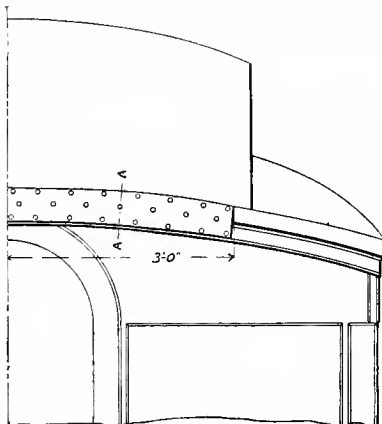

Fig. 2446. Hood-carcine Face-plate.
Applied to cars with vestibules to prevent diaphragm face-plate from crushing hood-carcine.

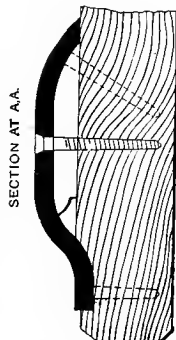

Fig. 2447.

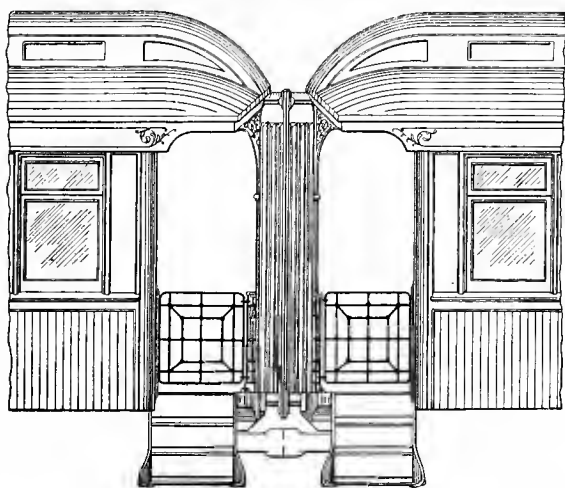

Fig. 2448. Side Elevation.

NAMES OF PARTS OF WINDOWS, ETC.

Figs. 2452-2453a.

- B. Window-balances.
- C. Drapery-curtain.
- D. Lower Wainscot-rail.
- E. Upper Wainscot-rail.
- F. Wainscot-panel.
- G. Wood Grille.
- H. Inside Window-cornice.
- J. Inside Window-sill.
- K. Pilaster.
- L. Mullion of Upper-sash.
- M. Molding of Window-post.
- N. Window Sash-stile.
- O. Window-sash Rail.
- P. Hot-water Pipes.
- Q. Hot-water-pipe Guard-rail.
- R. Basket or Bundle-rack.
- S. Lower-sash.
- T. Upper-sash, Leaded Glass.
- U. Window-lift.
- V. Window-stop.
- W. Electric Push-button.
- X. Table-hook Plate.
- Y. Curtain-hook.
- Z. Inside-cornice Sub-fascia-board.
- 1. Bracketed Window-cornice.
- 2. Corbeled Shelf.
- 3. Hat-posts.
- 4. Ornamental-carline.
- 5. Table.
- 6. Seat-end.
- 7. Seat-back.
- 8. Pivoted Seat-cushion.
- 9. Decorated-ceiling.
- 10. Candelabrum.
- 11. Mirror.

Fig. 2449. Elevation.

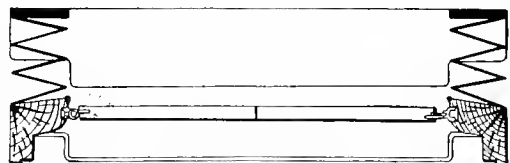
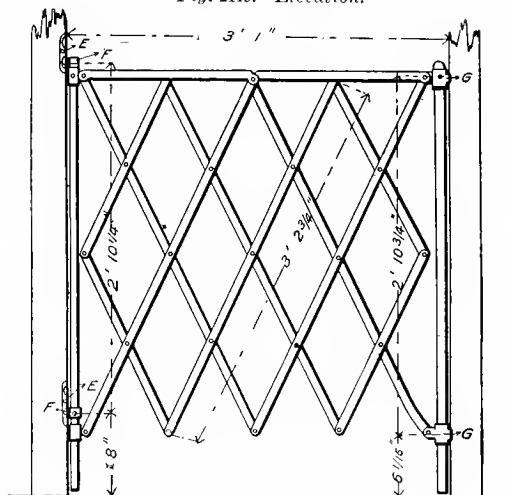

Fig. 2450. Plan.

PULLMAN'S ADJUSTABLE GATE FOR VESTIBULES.

Numbers refer to Lists of Names of Parts with Figs. 2442-2443 and Figs. 2445-2450.

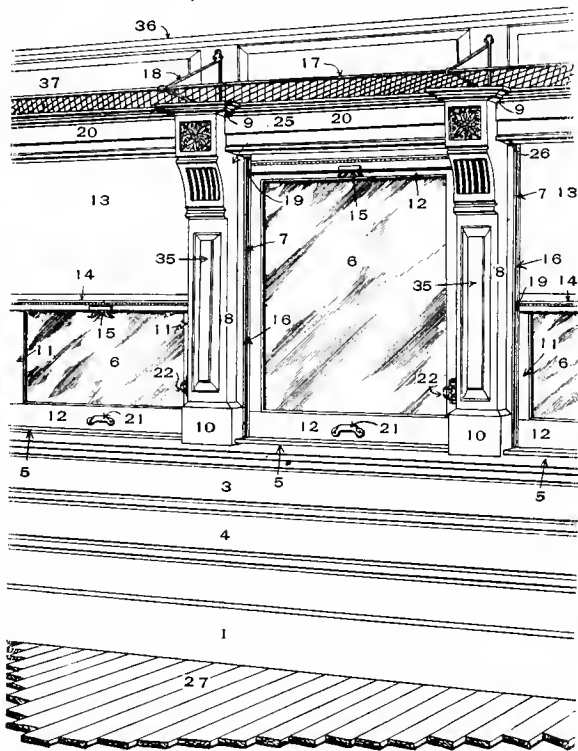

Fig. 2451.

PERSPECTIVE VIEW OF A COACH WINDOW.

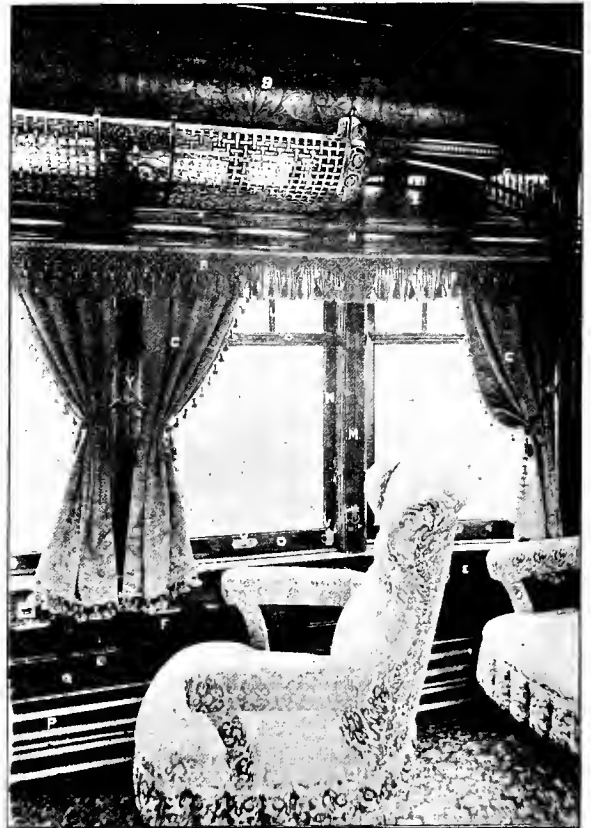

Fig. 2452.

PERSPECTIVE VIEW OF PARLOR-CAR WINDOW.

A Window of a Coach is shown in Fig. 541. Other views of Windows are shown under General Views of Passenger Car Interiors, Figs. 90-133, and also in Figs. 422, 435, 447, 464, 487 and Fig. 491. Sleeping-car Window is shown in Figs. 2408-2412.

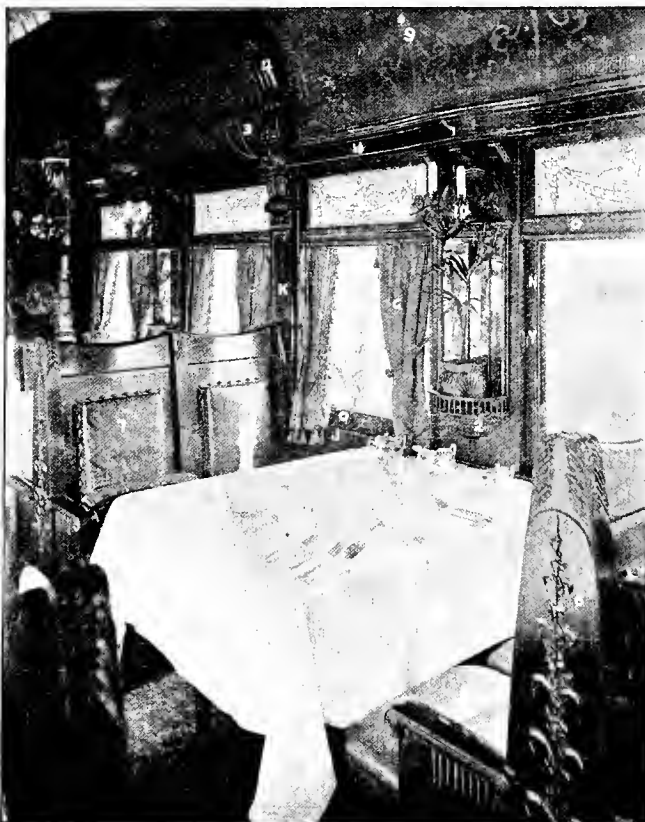

Fig. 2453.

PERSPECTIVE VIEW OF DINING-CAR WINDOWS, SEATS AND TABLE.

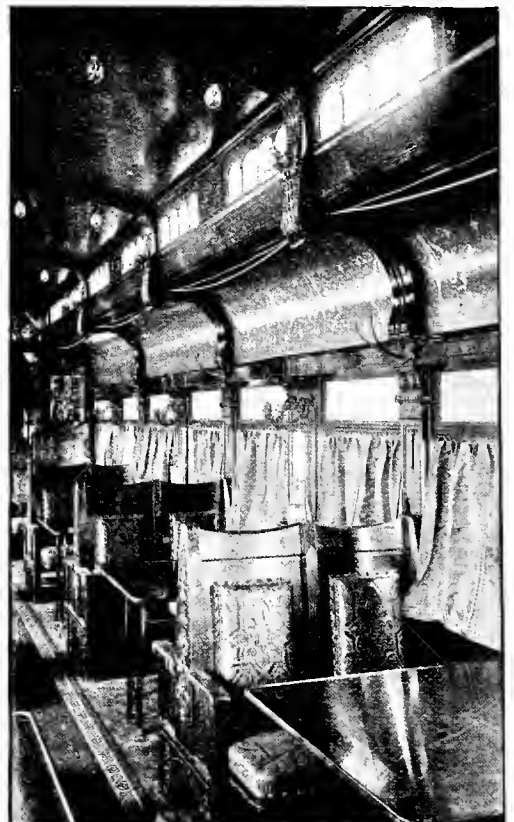

Fig. 2453a.

PERSPECTIVE VIEW OF DINING-CAR WINDOWS AND SEATS.

CAR FURNISHINGS.

Including those Parts of a Car that are Applied after the Car has Left the Paint Shop.

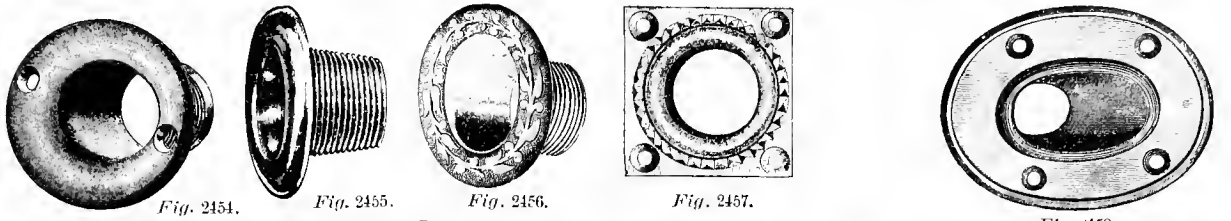

Fig. 2454.

Fig. 2455.

Fig. 2456.

Fig. 2457.

Fig. 2458.

BELL-CORD BUSHINGS.

BEVELED BELL-CORD BUSHING.



Fig. 2459.

BEVELED BELL-CORD BUSHING.

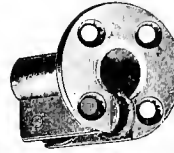
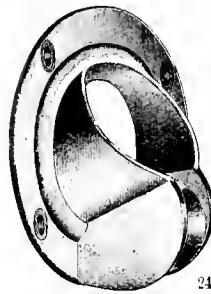

Figs.

2460-2462.

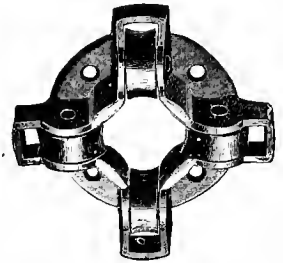

Fig. 2463.

QUARTET BELL-CORD BUSHING.

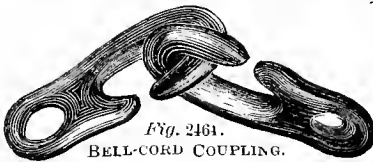

Fig. 2461.

BELL-CORD COUPLING.



Fig. 2465.

BELL-CORD COUPLING.



Figs. 2466-2467.

BELL-CORD HOOKS.



Figs. 2468-2469.

BELL-CORD COUPLINGS.



Fig. 2470.

BELL-CORD SPLICE.

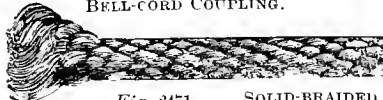

Fig. 2471.

SOLID-BRAIDED BELL-CORD.



Fig. 2473.

BELL-CORD SPLICES.



Fig. 2474.



Fig. 2475.

COUPLING.

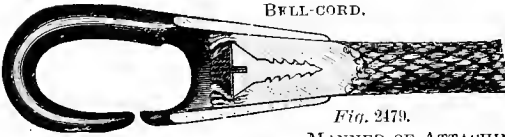

Fig. 2479.

MANNER OF ATTACHING BELL-CORD TO COUPLING.



Fig. 2476.



Fig. 2477.

GUIDES WITH SCREW.



Fig. 2478.



Fig. 2479.

Guide with Screw and Flange.



Fig. 2480.

Guide with Screw.

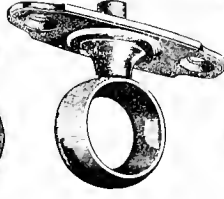

Fig. 2481.

Guide with Flange.



Fig. 2482.

Guide with Screw.



Fig. 2485.

Overhead Guides with Screw and Pulley.



Fig. 2486.



Fig. 2487.

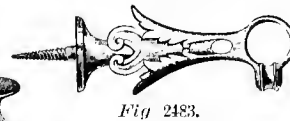

Fig. 2483.



Fig. 2488.

Side Guides with Screw and Pulley.

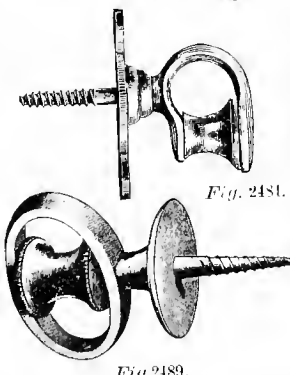

Fig. 2489.

Fig. 2481.

Overhead Swing Guide with Flange and two Pulleys.

BELL-CORD GUIDES. (ADAMS & WESTLAKE CO. AND DAYTON MFG. CO.)

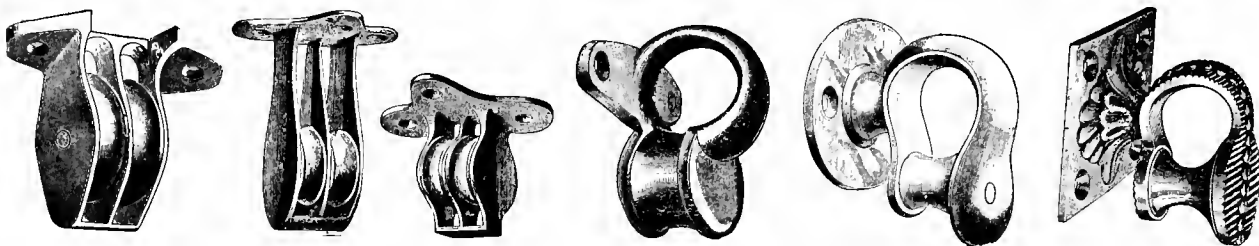

Fig. 2491. Fig. 2492. Fig. 2493. Fig. 2494. Fig. 2495. Fig. 2496.
Pulley-guides with Flanges. Side Pulley-guides with Flanges.

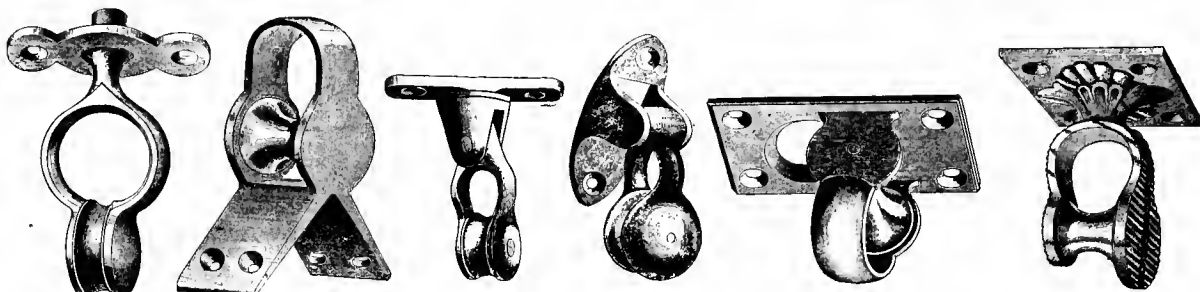

Fig. 2497. Fig. 2498. Fig. 2499. Fig. 2500. Fig. 2501. Fig. 2502.
Overhead Guide with Pulley, Flange and Stem. Corner Guide with Pulley. Swing Guides with Pulleys. Angle Guides with Flanges and Pulleys.

BELL-CORD PULLEY GUIDES. (ADAMS & WESTLAKE AND DAYTON MANUFACTURING COMPANIES.)

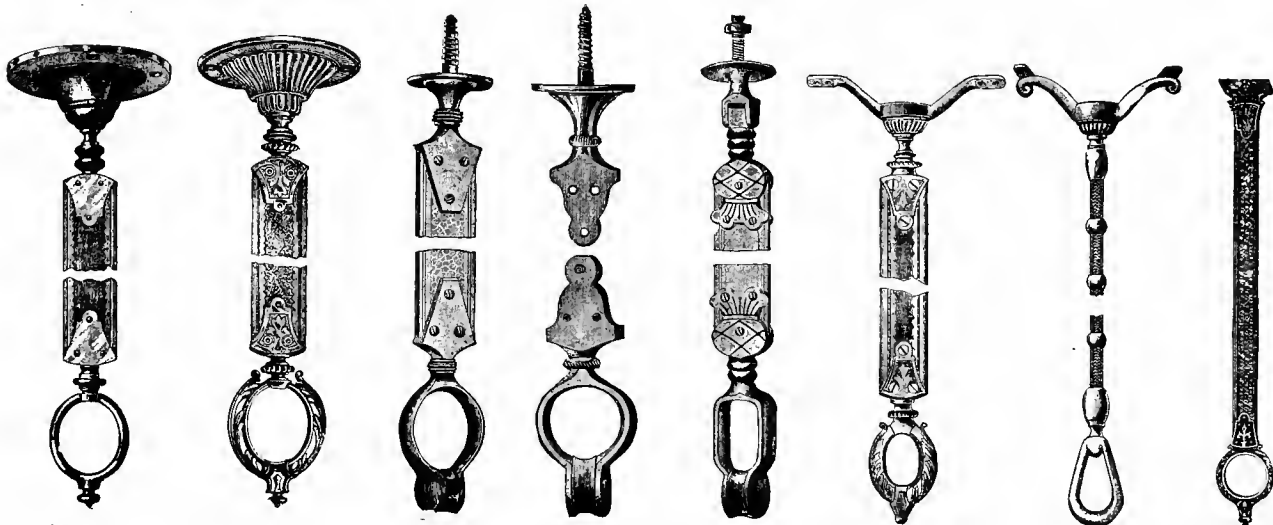

Fig. 2503. Fig. 2504. Fig. 2505. Fig. 2506. Fig. 2507. Fig. 2508. Fig. 2509. Fig. 2510.

BELL-CORD STRAP HANGERS.

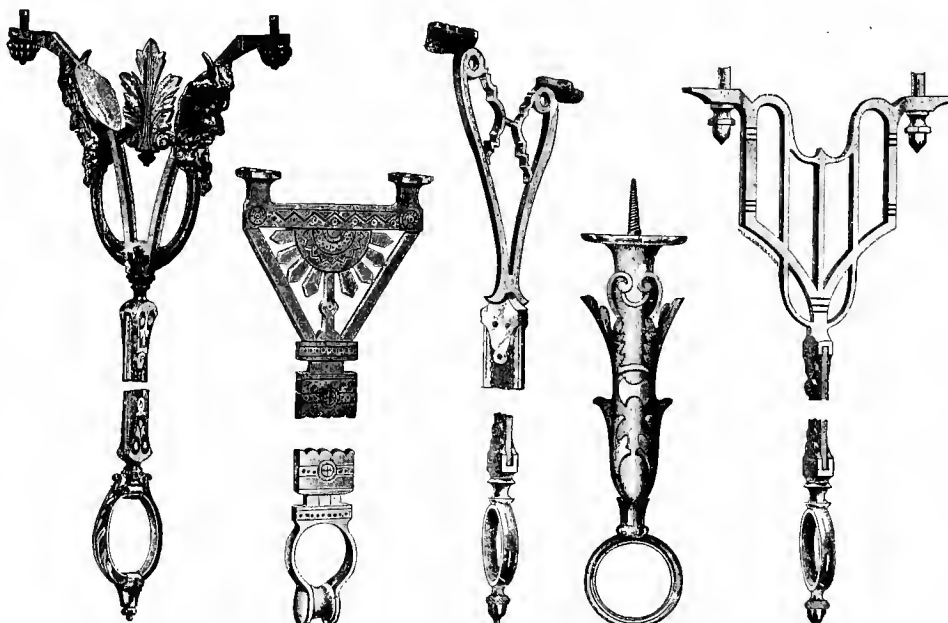

Fig. 2511. Fig. 2512. Fig. 2513. Fig. 2514. Fig. 2515.

BELL-CORD STRAP HANGERS, WITH DECORATED BRACKETS.

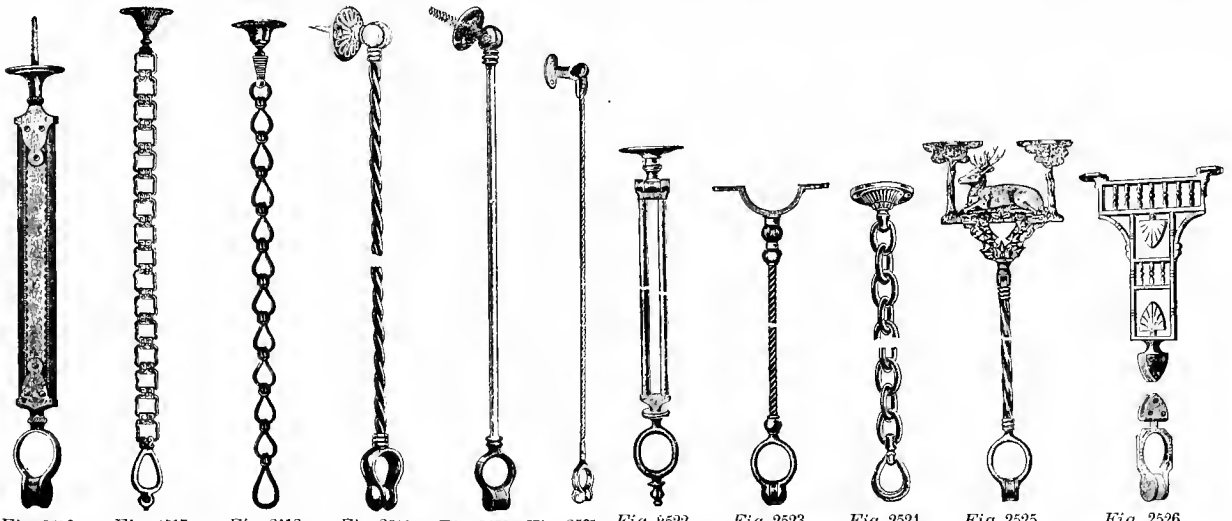

Fig. 2516. Fig. 2517. Fig. 2518. Fig. 2519. Fig. 2420. Fig. 2521. Fig. 2522. Fig. 2523. Fig. 2524. Fig. 2525. Fig. 2526.
 BELL-CORD BAND, CHAIN AND ROD HANGERS. BELL-CORD ROD, CHAIN AND BAND HANGERS.

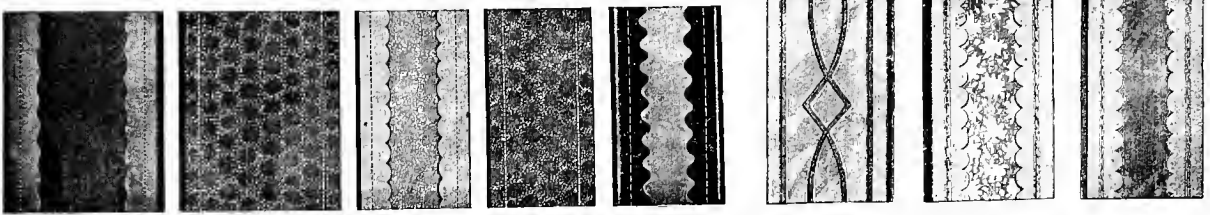

Fig. 2527. Fig. 2528. Fig. 2529. Fig. 2530. Fig. 2531. Fig. 2532. Fig. 2533. Fig. 2534.
 BELL-CORD HANGER STRAPS.

DOORS, HARDWARE AND TRIMMINGS; Bolts.



Fig. 2535. Fig. 2536. Fig. 2537. Fig. 2538. Fig. 2539.
 BARREL DOOR-BOLT WITH BENT STAPLE-PLATE. BARREL DOOR-BOLT AND KEEPER OR STAPLE. BARREL DOOR-BOLT WITH NECKED STAPLE. ROUND NECK DOOR-BOLT AND PLATE. A Substitute for Neck-bolts.

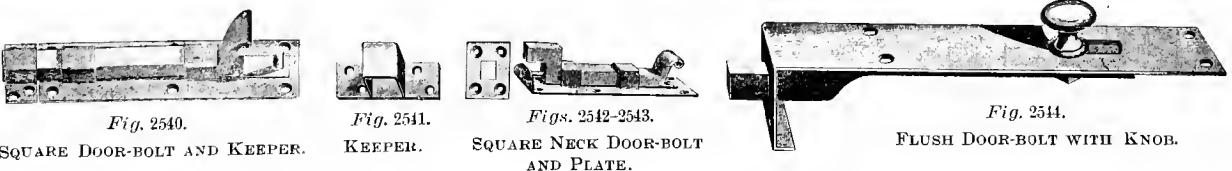
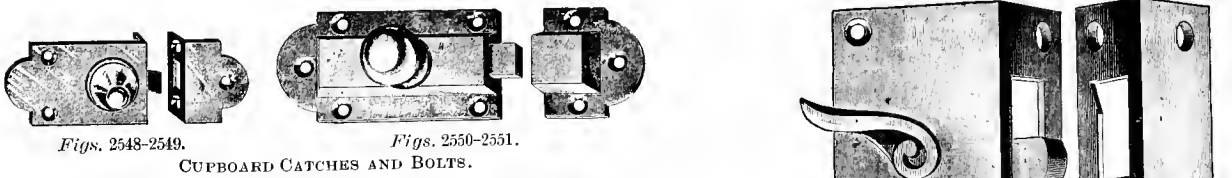

Fig. 2540. Fig. 2541. Figs. 2542-2543. Fig. 2544.
 SQUARE DOOR-BOLT AND KEEPER. KEEPER. SQUARE NECK DOOR-BOLT AND PLATE. FLUSH DOOR-BOLT WITH KNOB.



Fig. 2545. Fig. 2546. Fig. 2547.
 BOSTON-FINISH FLUSH DOOR-BOLT. STAPLE WITH BENT STRIKING-PLATE. STEEL-SPRING FLAT DOOR-BOLT.



Figs. 2548-2549. Figs. 2550-2551.
 CUPBOARD CATCHES AND BOLTS.

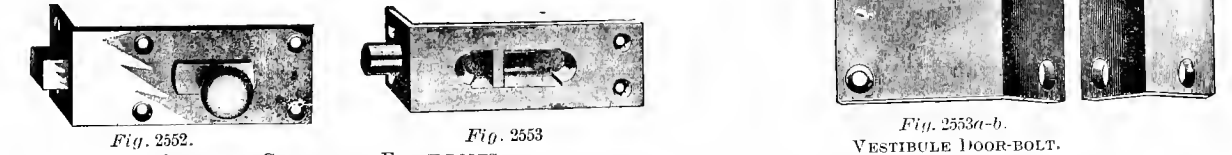
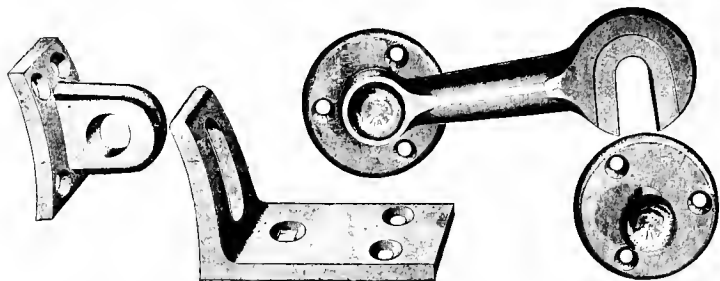
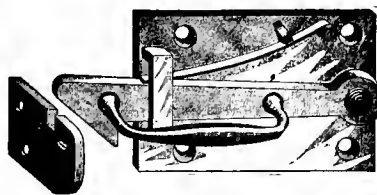

Fig. 2552. Fig. 2553. Fig. 2553a-b.
 CUPBOARD CATCHES OR FLUSH-BOLTS. VESTIBULE DOOR-BOLT.



Figs. 2551-2555. Sliding-door Husp and Stapl; for Mail-car.

Figs 2556-2557. Sliding-door Hook and Button for Baggage-car.



Figs. 2558-2559. Spring Latch and Keeper for Baggage-car Sliding-door.

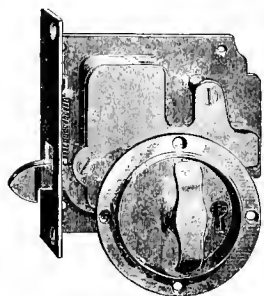
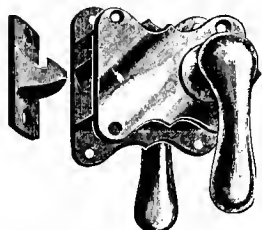
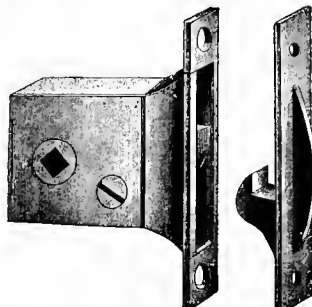

Fig. 2560. Sliding-door Flush Lock.



Figs. 2561-2562. Sliding-door Latch.



Figs. 2563-2561. Sliding-door Mortise-latch.



Fig. 2565. Spring Latch.

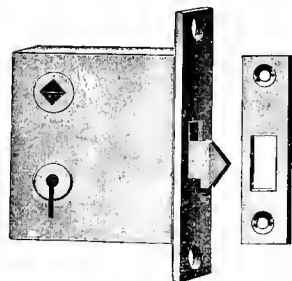

Figs. 2566-2567. Sliding-door Mortise Lock and Keeper.

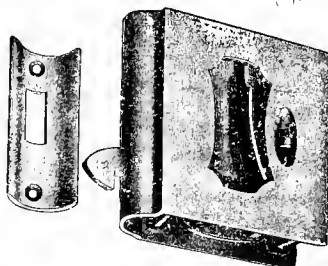

Figs. 2568-2569. Flush Sliding-door Mortise-latch and Keeper for Round-edge Door.

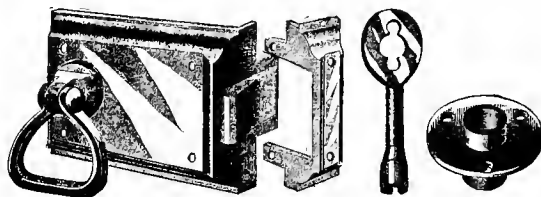

Figs. 2570-2573. Baggage-car Door Lock, Keeper, Key and Escutcheon.

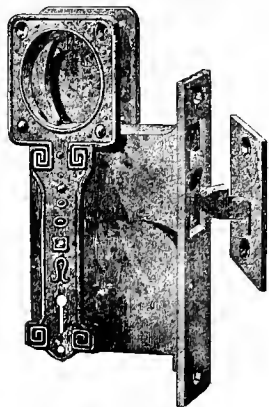

Figs. 2574-2575. Sliding-door Flush-lock.

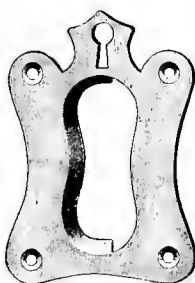
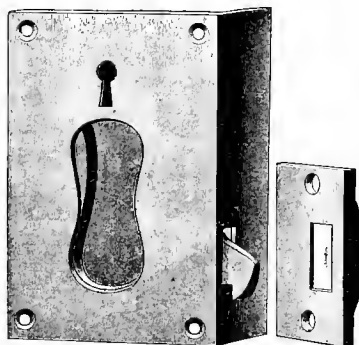

Fig. 2576. Sliding-door Flush-handle Lock and Keeper



Figs. 2577-2578. Sliding-door Flush-handle Lock and Keeper

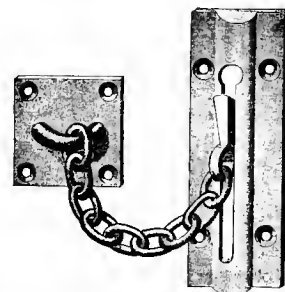
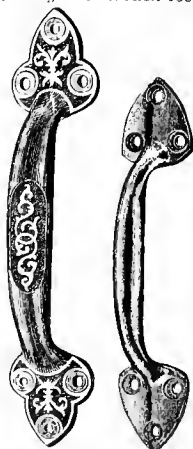

Fig. 2579. Door Chain-bolt.



Fig. 2581. Sliding-door Handle.



Figs. 2580-2581. Door-handles.

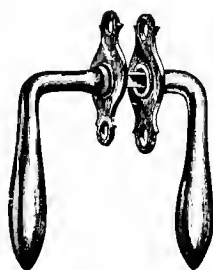

Fig. 2582. Door-handles for Sliding-doors.

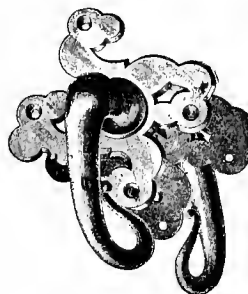

Fig. 2583.

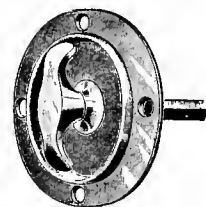

Fig. 2585. Flush Door-handle.

LATCHES, LOCKS AND HANDLES FOR BAGGAGE AND MAIL-CAR DOORS.

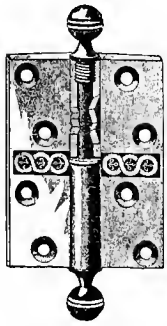
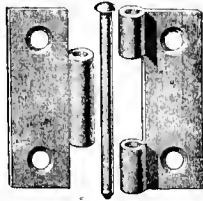

Fig. 2586.
ACORN BUTT-HINGE. LOOSE-PIN REVERSIBLE
Knuckle broken open
to show washer-bearing.



Figs. 2587-2589
LOOSE-PIN REVERSIBLE
BUTT-HINGE.

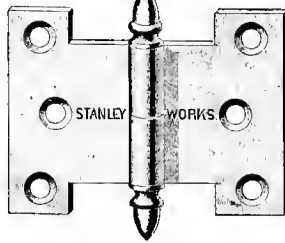

Fig. 2590.
PARLIAMENT HINGE.

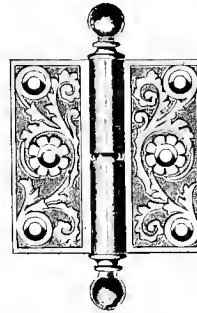

Fig. 2591.
LOOSE-JOINT ACORN BUTT-HINGES, WITH WASHERS.

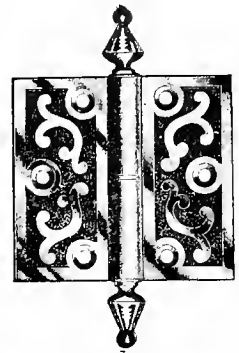

Fig. 2592.

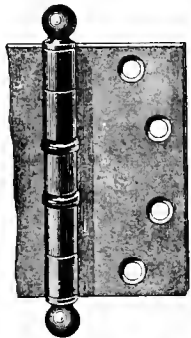

Fig. 2593. LOOSE-PIN BUTT-HINGE, WITH BALL-BEARING WASHERS.



Fig. 2594.
Washer-cap.

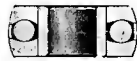

Fig. 2595.
Washer Complete.



Fig. 2596.
Washer-base.



Fig. 2597.
Ball-guide.

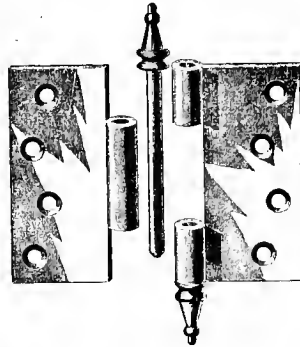

Figs. 2598-2600.
LOOSE-PIN BUTT HINGE.

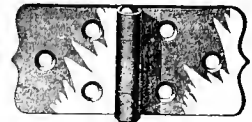

Fig. 2601. HOPPER BUTT-HINGE.

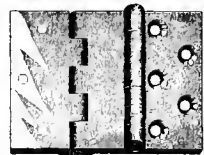

Fig. 2602. TABLE HINGE.



Fig. 2603.
VESTIBULE-DOOR HINGES, COVERED WITH BRASS.

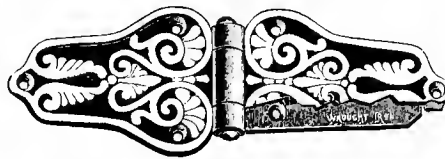

Fig. 2604.

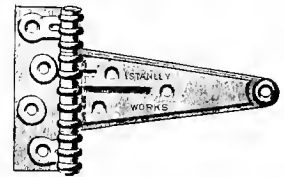

Fig. 2605.
T-HINGE.

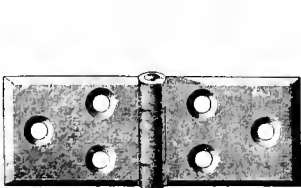

Fig. 2606.
BUTT-HINGE, RIVETED JOINT.

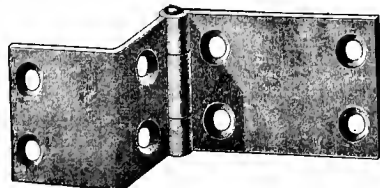

Fig. 2607.
OFFSET BUTT-HINGE, RIVETED JOINT.

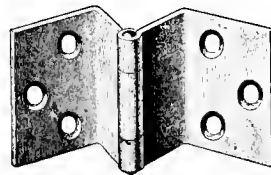

Fig. 2608.
POCKET-HINGE.

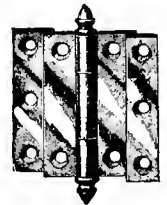
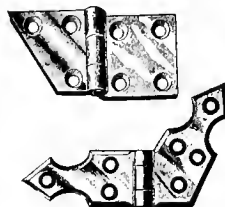

Fig. 2609.
VESTIBULE HINGE
FOR RABBETED DOOR.



Fig. 2610.
DISTRIBUTING-TABLE HINGE FOR
POSTAL-CARS.



Figs. 2611-2612.
LAMP-HOUSE HINGES.

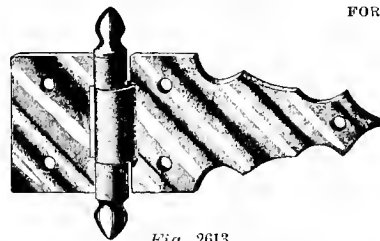

Fig. 2613.
REFRIGERATOR-DOOR HINGE.

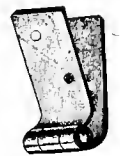

Fig. 2614.
LAMP-HOUSE
HINGE.

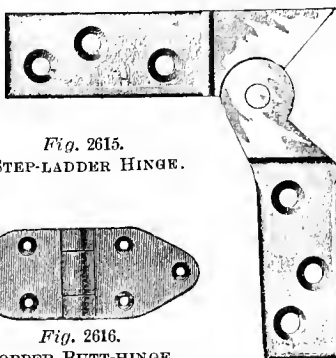

Fig. 2615.
STEP-LADDER HINGE.

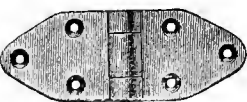

Fig. 2616.
HOPPER BUTT-HINGE.

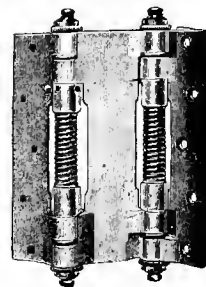

Fig. 2617.
DOUBLE-ACTING SPRING-
HINGE.



Fig. 2618.
DOUBLE-ACTING
SPRING-HINGE.

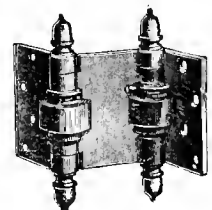

Fig. 2620.
DOUBLE-ACTING
SPRING-HINGE.



Fig. 2621.



Fig. 2622.



Fig. 2623.



Fig. 2624.

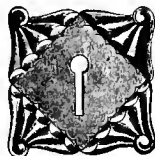

Fig. 2625.

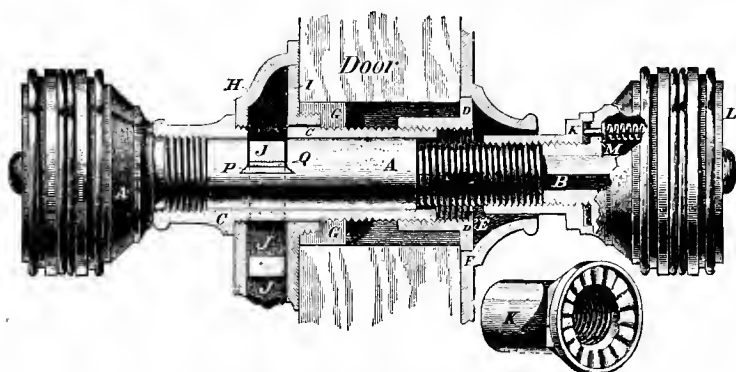

Fig. 2626.



Fig. 2627.

KRY-HOLE ESCUTCHEONS.



Figs. 2628-2629. Screwless Knob and Spindle
KIRBY'S CAR-DOOR LOCK.

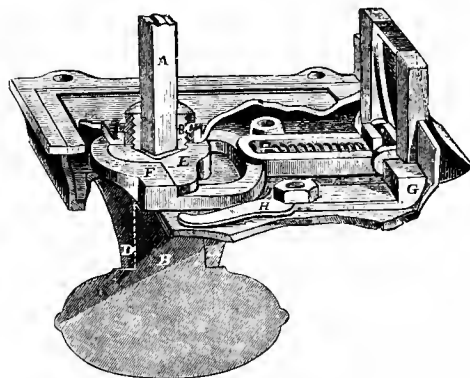

Fig. 2630. Screwless Knob and Spindle (o'd style).
CAR-DOOR LOCK.

NAMES OF PARTS. Figs. 2628-2629.

- A. Inside Door-knob.
- A'. Shank.
- B. Spindle.
- C. Sleeve.
- D. Outside Sleeve-collar.

- E. Door-latch Rose.
- F. Lock-nut.
- G. Inside-shell.
- H. Back-plate.
- I. Latch-pull.

- K. Coupling-sleeve.
- L. Outside-knob.
- M. Ratchet-bolt.
- P. Shank-facing.
- Q. Latch-bolt Facing.

NAMES OF PARTS. Fig. 2630.

- A. Spindle.
- B. Door-knob.
- C. Flange-collar.
- D. Sleeve.
- F. Yoke.
- G. Stop-bolt.

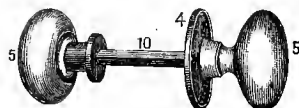

Fig. 2631.
DOOR-KNOBS, SPINDLE AND ROSE.



Fig. 2632.
SCREWLESS KNOB-SHANK AND KNOB.

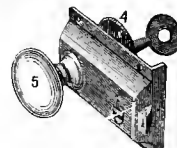
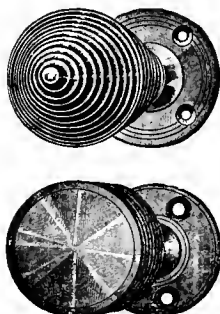

Fig. 2633.
SPRING DOOR-LATCH OR NIGHT-LATCH.



Figs. 2634-2635.
DOOR-KNOBS AND ROSETTES.



Fig. 2636.
FLUSH DOOR-HANDLE
AND ESCUTCHEON.

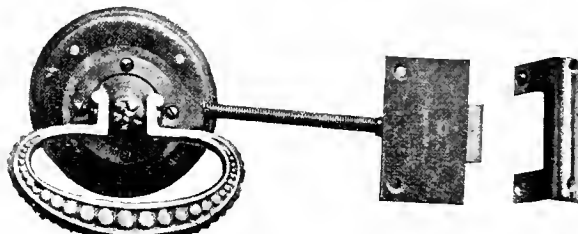

Figs. 2637-2638.
PLATFORM VESTIBULE DOOR-LATCH.



Fig. 2639.
DOOR-KNOB AND
SPINDLE.

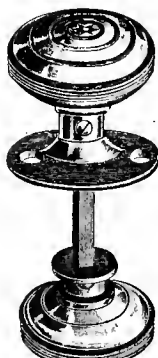

Fig. 2640.
DOOR-KNOBS, SPINDLES AND ROSES



Fig. 2641.

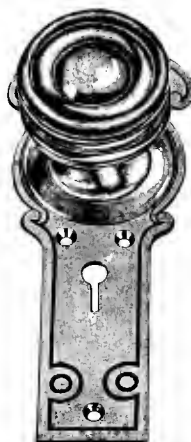
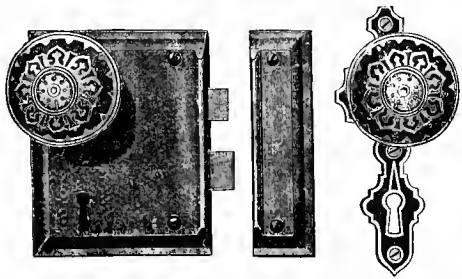

Fig. 2642.
DOOR-KNOB AND
ESCUTCHEON-PLATE.

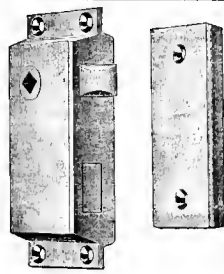

Fig. 2643.
DOOR-HANDLES, ESCUTCHEON-PLATE
AND ROSE.



Figs. 2644-2645. Fig. 2646.

END-DOOR LOCK, KEEPER, ROSE AND ESCUTCHEON.



Figs. 2647-2648. LINEN-CLOSET LOCK AND KEEPER.

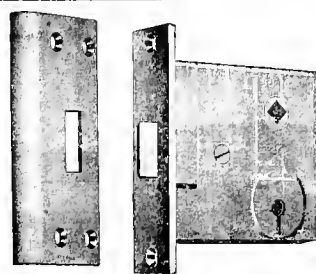

Figs. 2649-2650. MORTISE-DOOR-LOCK AND ESCUTCHEONS.



2651-52.

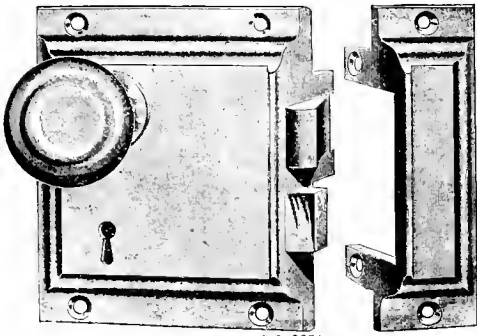

Figs. 2653-2654. END-DOOR LOCK AND KEEPER.

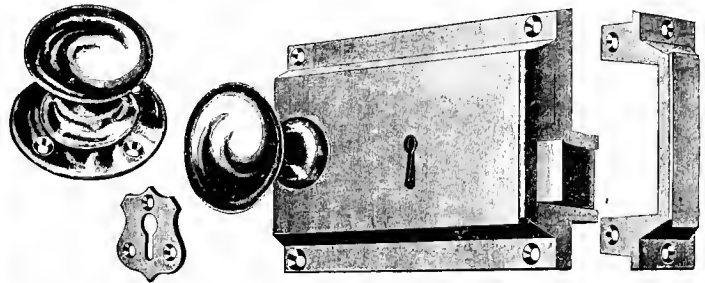

Figs. 2655-2658. END-DOOR LOCK, KEEPER, KNOB AND ESCUTCHEON.

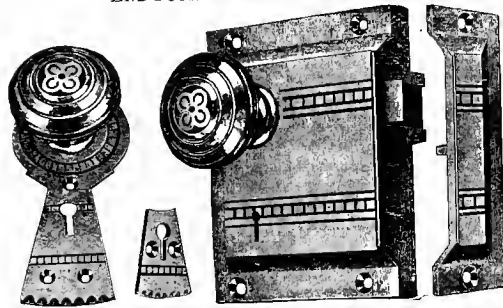

Figs. 2659-2662. END-DOOR LOCK, KEEPER, ESCUTCHEON AND ROSE.

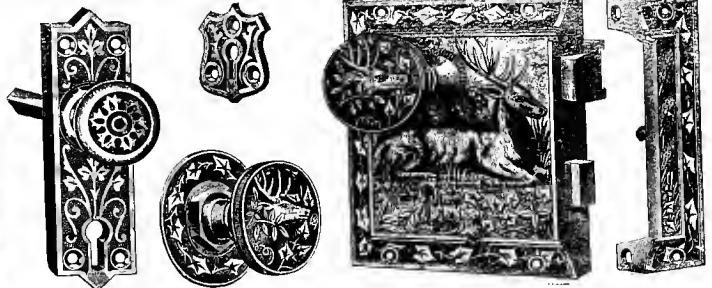

Figs. 2663-2667. END-DOOR LOCK, KEEPER ROSE AND ESCUTCHEON.

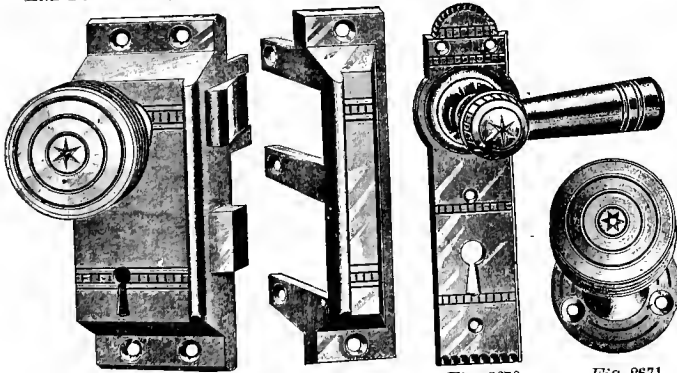

Figs. 2668-2669. END-DOOR LOCK, KEEPER, KNOBS, ESCUTCHEON AND ROSE.

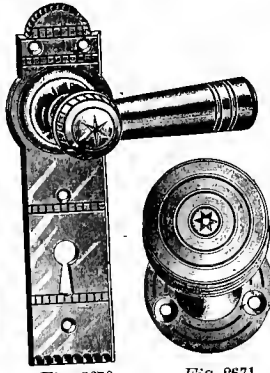
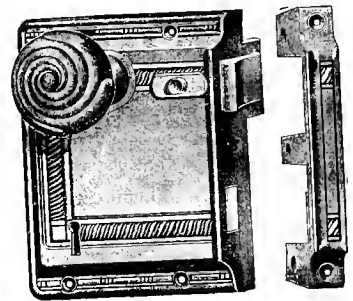

Fig. 2670.

Fig. 2671.



Fig. 2672.



Figs. 2673-2674. COMBINED END-DOOR LOCK AND NIGHT-LATCH, KEEPER AND ESCUTCHEON-PLATE.

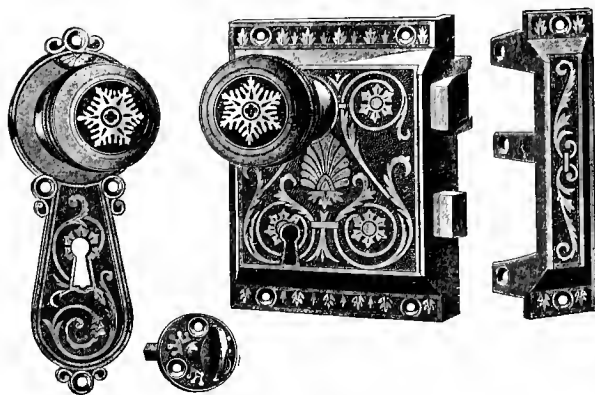

Figs. 2675-2678.

END-DOOR LOCK, KEEPER, ESCUTCHEON-PLATE AND THUMB-LATCH.

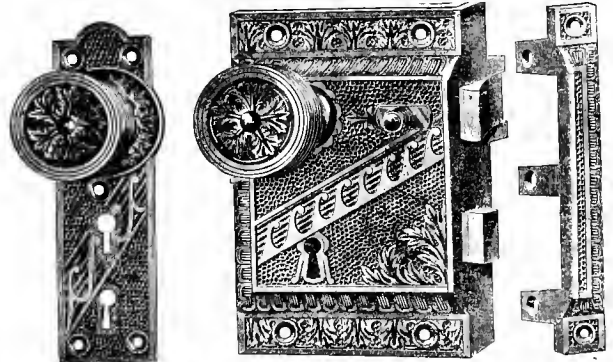

Figs. 2679-2681.

COMBINED END-DOOR LOCK AND NIGHT-LATCH, KEEPER AND ESCUTCHEON-PLATE.

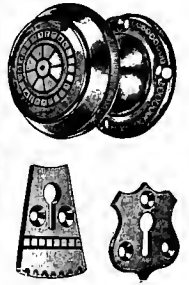
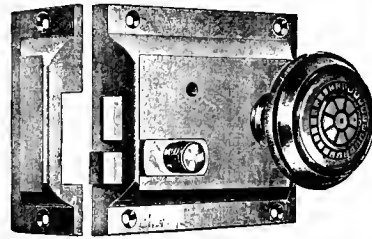
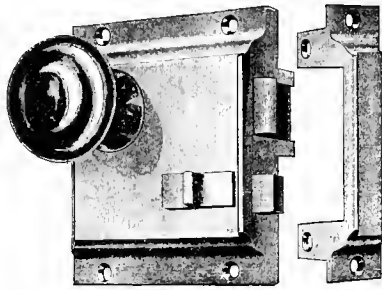
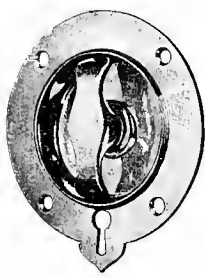

Figs. 2682-2684.

SALOON-DOOR LOCK, KEEPER AND FLUSH HANDLE.

Figs. 2685-2688.

SALOON-DOOR LOCK, KNOBS AND ESCUTCHEONS.

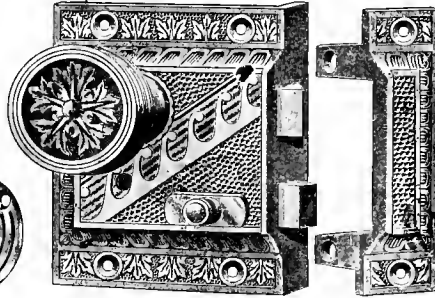
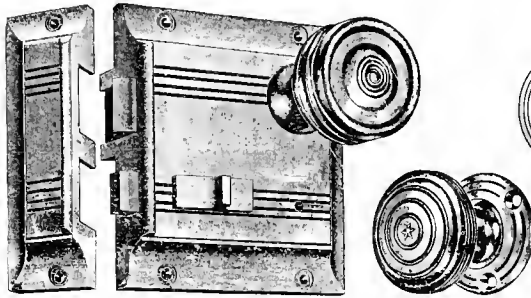

Figs. 2689-2691.

SALOON-DOOR LOCK, KEEPER AND KNOB.

Figs. 2692-2694.

SALOON-DOOR LOCK, KEEPER AND FLUSH HANDLE.

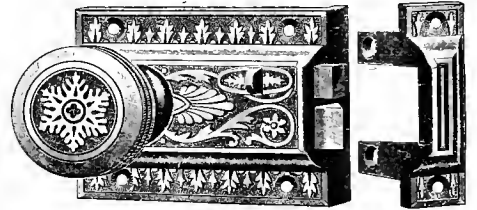
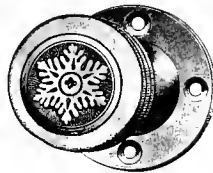
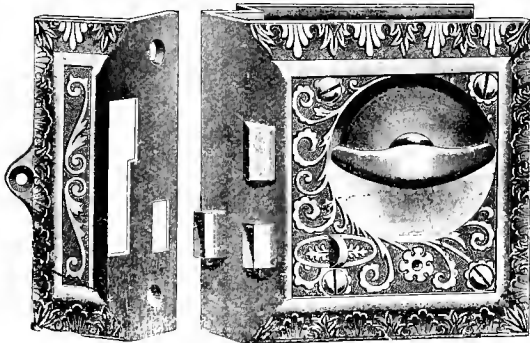

Figs. 2695-2696.

SALOON-DOOR LOCK, EXTRA BOLT AND KEEPER.

Figs. 2697-2699.

SALOON-DOOR LOCK, KEEPER AND KNOB.

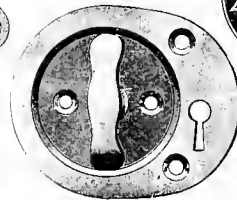
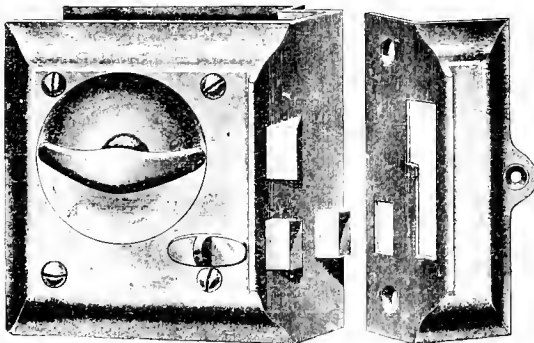

Figs. 2700-2701.

SALOON-DOOR LOCK, KEEPER AND FLUSH HANDLE.

Figs. 2702-2703.

SALOON-DOOR LOCK AND KEEPER.

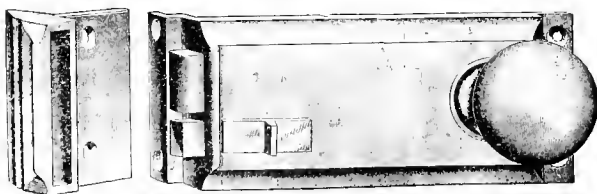

Figs. 2704-2705.

EXTRA LONG SALOON-DOOR LOCK AND KEEPER.

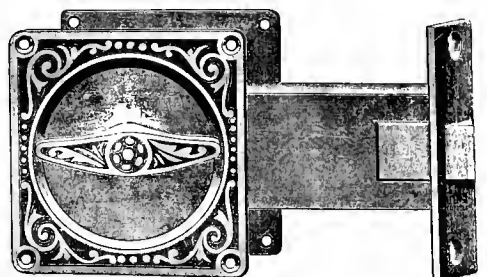
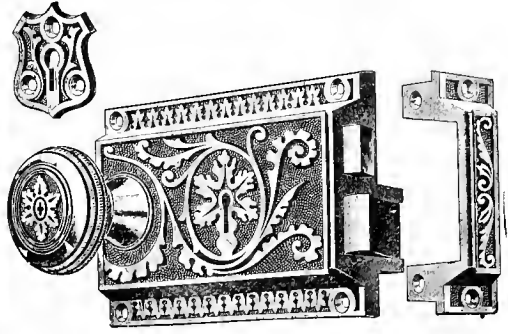
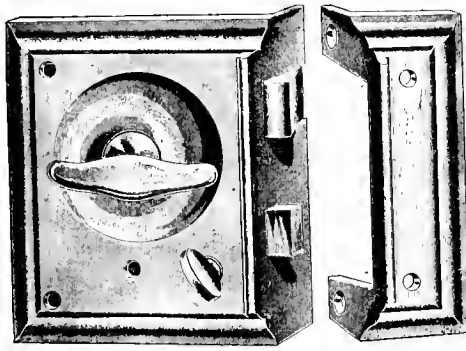
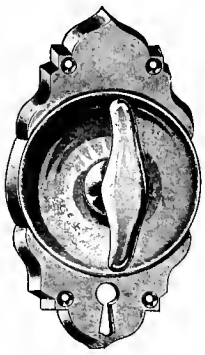

Fig. 2706.

VESTIBULE-DOOR MORTISE-LATCH.



Figs. 2707-2710.

DOUBLE FLUSH-HANDLE SALOON-DOOR LOCK AND KEEPER.

Figs. 2711-2713.

END-DOOR LOCK, KEEPER AND ESCU

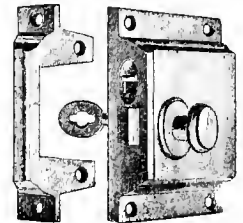
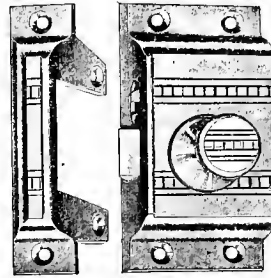
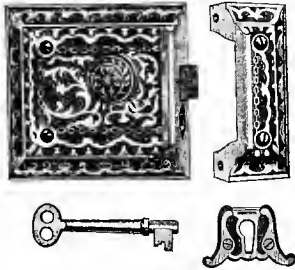
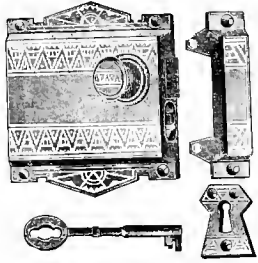

Figs. 2714-2717.

NIGHT-LATCH, KEEPER, KEY AND ESCUTCHEON.

Figs. 2718-2721.

NIGHT-LATCH, KEEPER, KEY AND ESCUTCHEON.

Figs. 2722-2723.

NIGHT-LATCH AND KEEPER.

Figs. 2724-2725.

NIGHT-LATCH AND KEEPER.

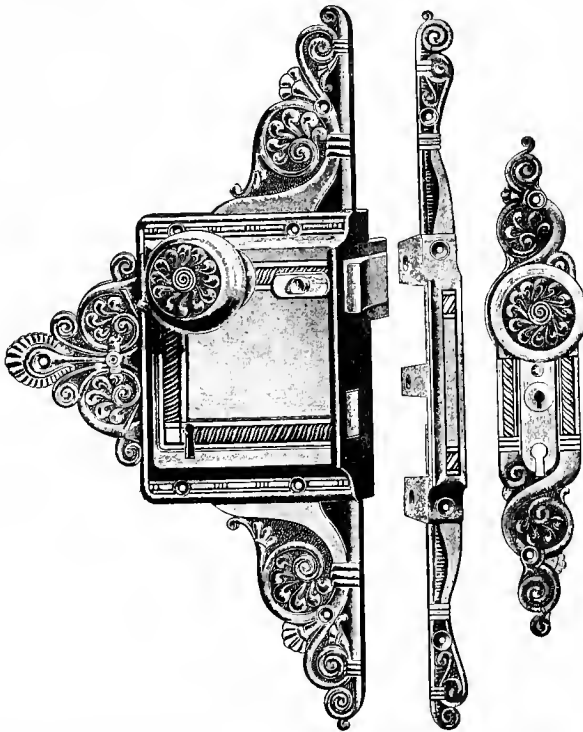

Figs. 2726-2728.

COMBINATION END-DOOR LOCK AND NIGHT-LATCH.

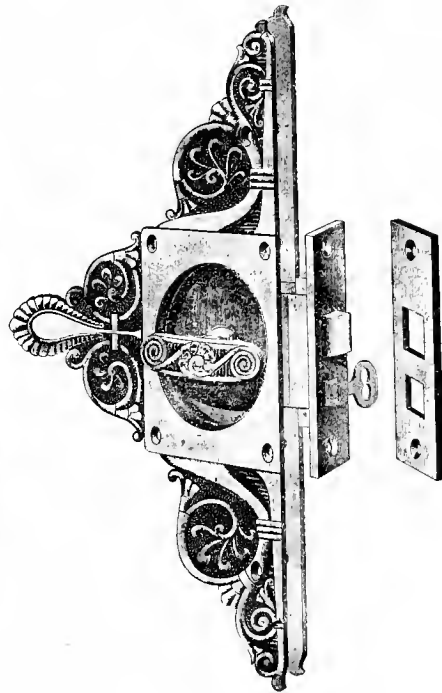

Figs. 2729-2730.

DOUBLE FLUSH-HANDLE SALOON-DOOR LOCK

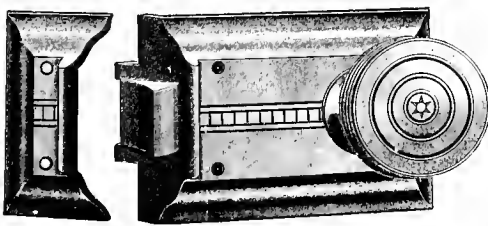
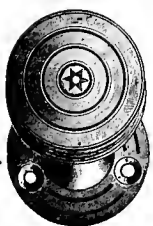

Figs. 2731-2733.

SALOON-DOOR LATCH, KEEPER, KNOB AND ROSE.

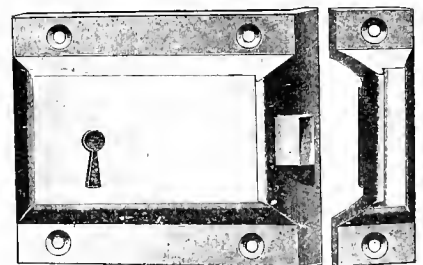

Figs. 2734-2735.

DEAD-LOCK, WITH KEEPER.

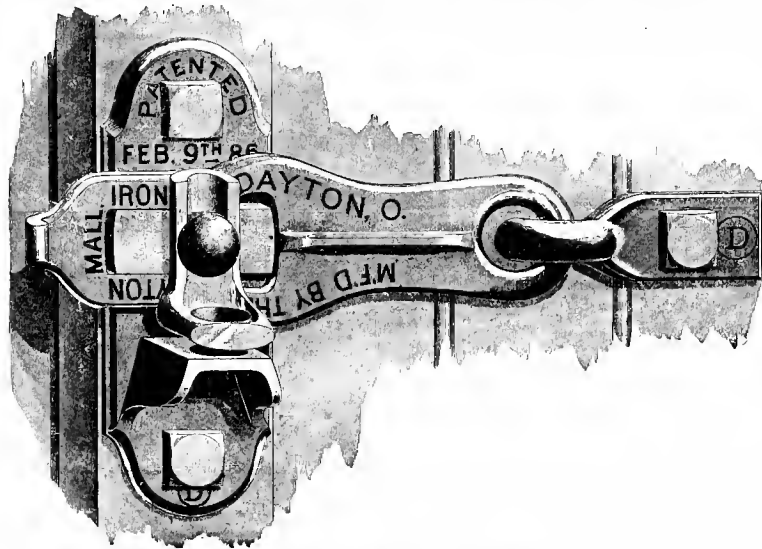

Fig. 2736. Lock closed ready for Pin or Seal

FREIGHT-CAR DOOR-LOCK, MALLEABLE IRON.

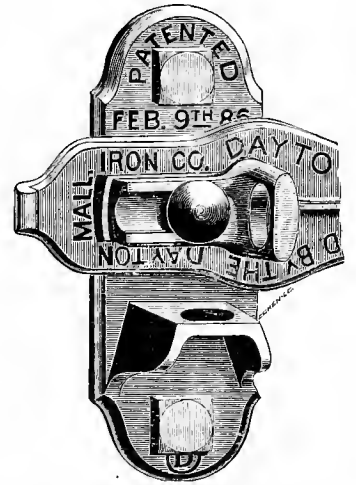
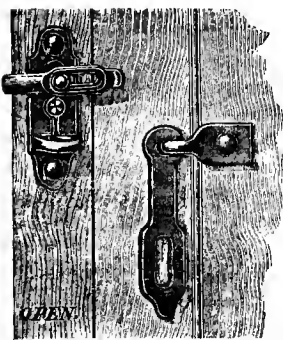
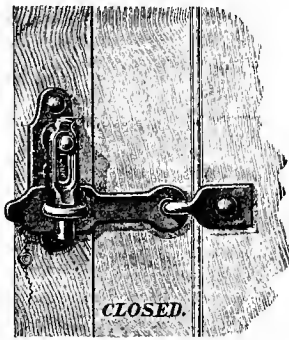

Fig. 2737. Lock in position to release Hasp.



OPEN



CLOSED

Figs. 2758-2759. FREIGHT-CAR DOOR-LOCK. Opened and Closed.

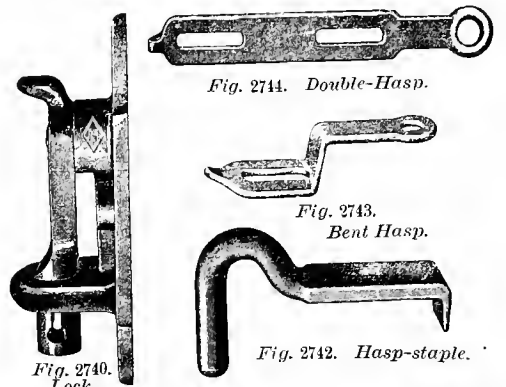

Fig. 2740. Lock.



Fig. 2741. Hasp.



Fig. 2742. Bent Hasp.



Fig. 2743. Double-Hasp.

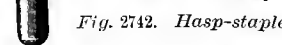

Fig. 2744. Hasp-staple.



Fig. 2745. Stationary Seal-holder. PARTS OF FREIGHT-CAR DOOR-LOCK.



Fig. 2746. PAPER AND GLASS SEAL-HOLDER. (U. S. Customs.)

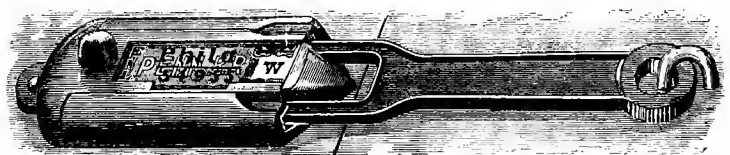
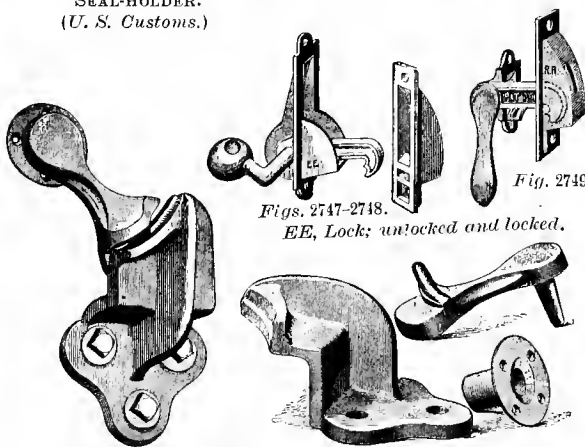
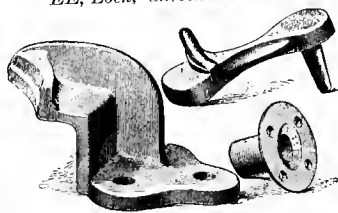

Fig. 2747. STATIONARY SEAL-HOLDER. FREIGHT-CAR DOOR-LOCKS.



Figs. 2747-2748. EE, Lock; unlocked and locked.

Fig. 2752. Howard Lock.



Figs. 2753-2755. Howard Lock Parts.



Fig. 2750. SS, Lock.

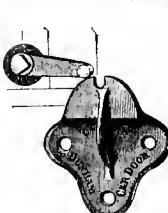

Figs. 2756-2757. Hix Drop Lock.



Fig. 2751. Catch for E Lock.

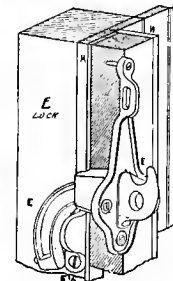

Fig. 2758. E Lock.

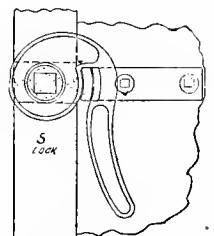
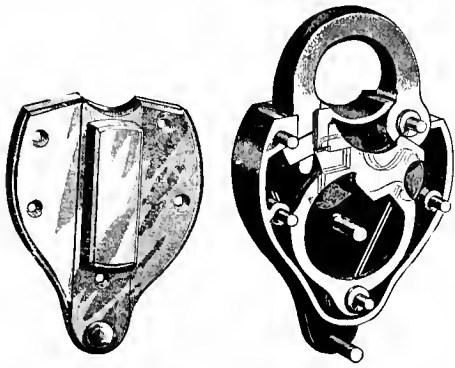

Fig. 2759. Simms Lock.

LOCKS MADE BY THE Q. & C. COMPANY.
(For other Freight-car Door Fastenings, see Car-doors.)



Figs. 2760-2761.
RAILROAD PADLOCK, MALLEABLE IRON.

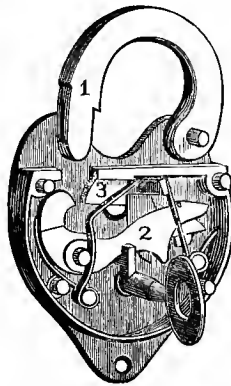

Fig. 2762.
RAILROAD PADLOCK.
Cheap grade with external EARS
for shackle.

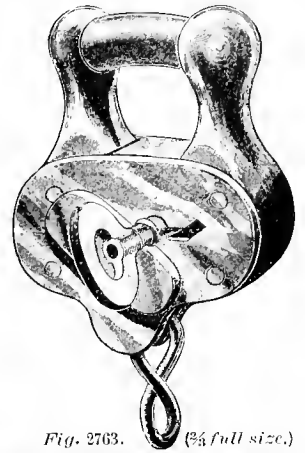

Fig. 2763. (¾ full size.)
RAILROAD PADLOCK, BAR SHACKLE

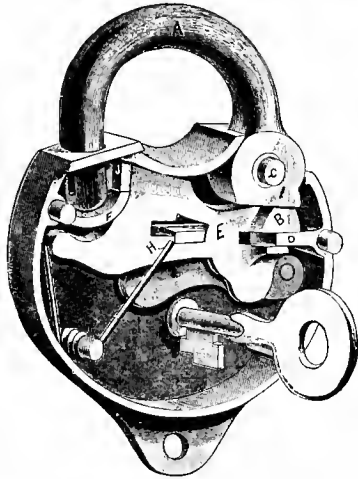

Fig. 2764. Closed.
(¾ full size.)

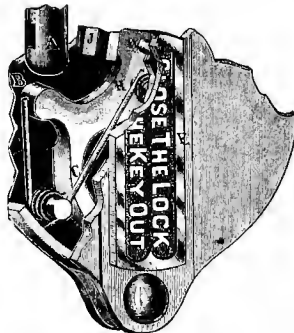
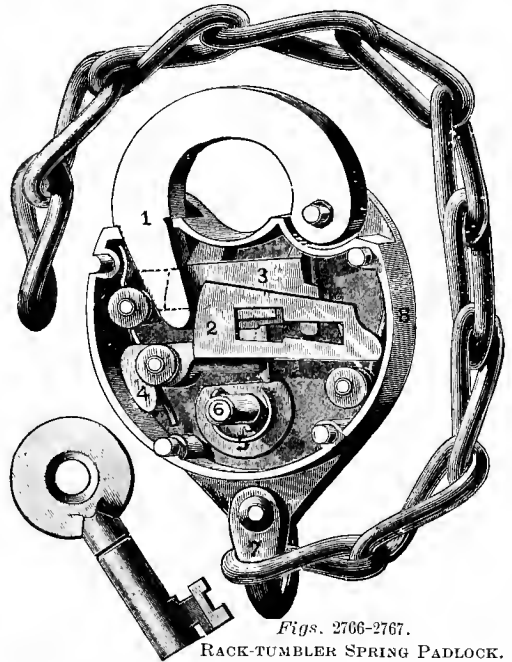

Fig. 2765.
Showing manner in which escutcheon
drops into place.

KEY-RETAINING RAILROAD PADLOCK.



Figs. 2766-2767.
RACK-TUMBLER SPRING PADLOCK.

NAMES OF PARTS. Figs. 2766-2767.

- | | |
|------------------|------------|
| 1. Shackle. | 5. Ward. |
| 2. Tumbler. | 6. Pivot. |
| 3. Sliding Bolt. | 7. Clevis. |
| 4. Tumbler. | 8. Case. |

NAMES OF PARTS. Figs. 2768-2770.

- | | |
|--------------------|--------------------|
| A. Tumbler. | E. Tumbler. |
| B. Shackle. | F. Tumbler-spring. |
| C. Tumbler-dog. | G. Key-hole. |
| D. Shackle-spring. | H. Shackle-stop. |

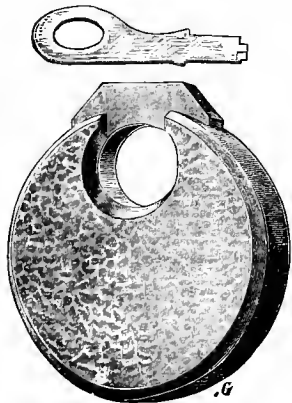

Fig. 2768-2769. Outside View.

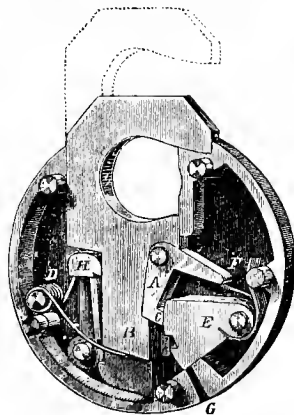

Fig. 2770. Interior View.

MILLER'S SELF-LOCKING PADLOCK.

NAMES OF PARTS. Figs. 2771-2772.

- | |
|--------------------------|
| A. Shackle. |
| B. Sliding Bolt. |
| C. Tumbler. |
| D. Heel, of Shackle. |
| E. Bit, of Sliding Bolt. |
| F. Shackle-guard. |
| G. Shackle-spring. |
| H. Sliding-bolt Spring. |
| I. Shackle-springs. |
| K. Tumbler. |
| L. Key Pin. |

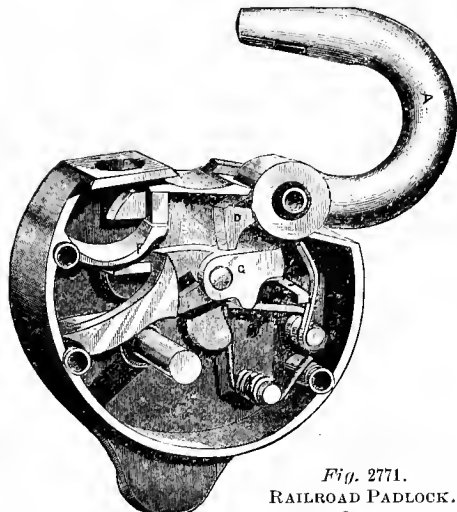

Fig. 2771.
RAILROAD PADLOCK.
Open.

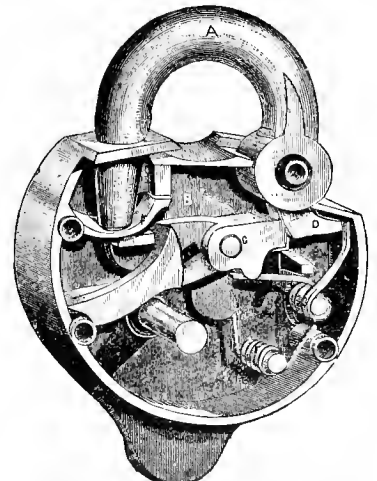

Fig. 2772. RAILROAD PADLOCK.



Fig. 2773.
Size, 2 $\frac{3}{4}$ × 10 $\frac{1}{2}$ ins.



Fig. 2774.
Size, 4 $\frac{3}{4}$ × 13 $\frac{3}{4}$ ins.



Fig. 2775.
Size, 3 $\frac{1}{4}$ × 12 $\frac{3}{4}$ ins.



Fig. 2776.
Size, 3 $\frac{1}{2}$ × 12 ins.



Fig. 2777.
Size, 3 $\frac{3}{4}$ × 11 $\frac{1}{2}$ ins.

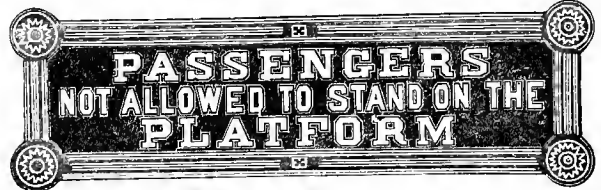

Fig. 2778.
Size, 3 $\frac{1}{4}$ × 11 $\frac{1}{2}$ ins.



Fig. 2779.
Size, 3 $\frac{3}{4}$ × 12 $\frac{1}{2}$ ins.

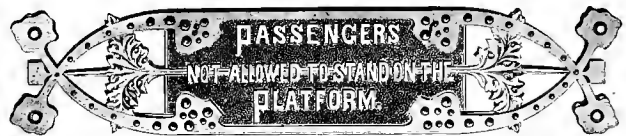

Fig. 2780.
Size, 2 $\frac{1}{4}$ × 13 ins.



Fig. 2781.
Size, 5 $\frac{1}{4}$ × 12 $\frac{3}{4}$ ins.



Fig. 2782.
Size, 4 × 9 $\frac{3}{4}$ ins.

PLATFORM NOTICE PLATES.



Fig. 2783.
Size, 2 $\frac{3}{4}$ × 11 ins.



Fig. 2784.
Size, 2 $\frac{1}{4}$ × 8 $\frac{3}{4}$ ins.



Fig. 2785.
Size, 2 $\frac{1}{4}$ × 9 ins.



Fig. 2786.
Size, 2 × 7 $\frac{1}{2}$ ins.



Fig. 2787.
Size, 2 × 6 $\frac{1}{2}$ ins.



Fig. 2788.
Size, 3 $\frac{1}{4}$ × 9 ins.



Fig. 2789.
Size, 2 × 7 $\frac{3}{4}$ ins.



Figs. 2790-2791. NOTICE FRAMES.
Any size desired.



Fig. 2792.
Size, 3 × 14 $\frac{1}{2}$ ins.



Fig. 2793.
Size, 3 × 14 $\frac{1}{2}$ ins.

DOOR NOTICE PLATES.



Fig. 2794.
Size, 2 x 5 3/8 ins.

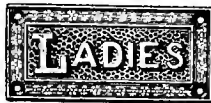

Fig. 2795.
Size, 2 x 4 3/8 ins.



Fig. 2796.
Size, 2 x 7 1/2 ins.



Fig. 2797.
Size, 2 x 2 ins.



Fig. 2798.
Size, 1 1/2 x 9 ins.



Fig. 2799.
Size, 1 1/2 x 9 ins.



Fig. 2800.
Size, 9 3/4 x 16 3/4 ins.



Fig. 2801.
Size, 9 3/4 x 16 3/4 ins.
DOOR NOTICE PLATES.

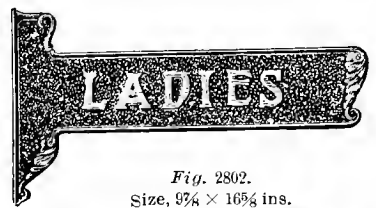
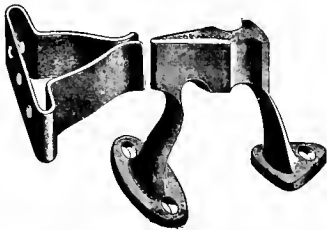
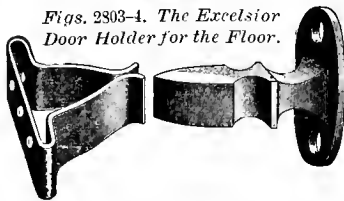

Fig. 2802.
Size, 9 3/4 x 16 3/4 ins.



Figs. 2803-4. The Excelsior
Door Holder for the Floor.



Figs. 2805-2806. The Excelsior Door
Holder for the Partition.



Figs. 2807-2808.
Door Holder.



Figs. 2809-2810.
Door Holder.

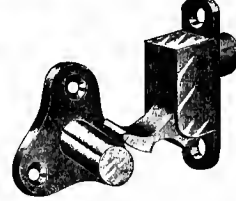

Figs. 2811-12. Door Holder
for Sliding Door.



Figs. 2813-2814.
Door Holder.

DOOR HOLDERS AND STOPS.

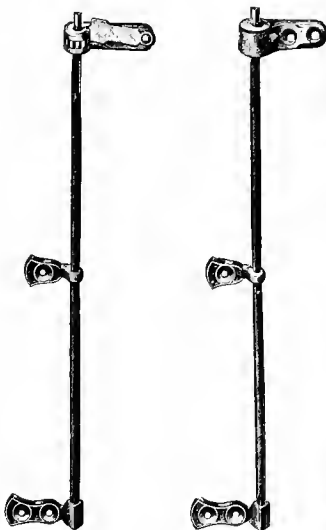

Fig. 2815
TORREY
DOOR-SPRING.

Fig. 2816.
"BEK"
DOOR-SPRING.



Fig. 2817.
"GEM"
DOOR-SPRING.

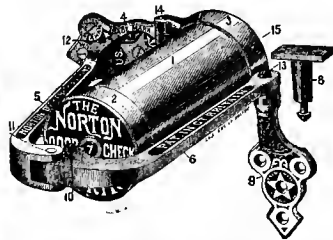

Fig. 2319. THE NORTON DOOR-CHECK.

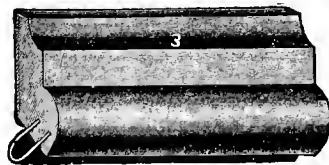

Fig. 2820.
For the Center of Double Doors.

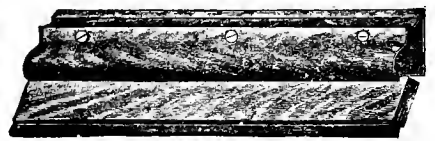

Fig. 2819. SPRING-DOOR BOTTOM.



Fig. 2821.
Rubber Threshold.



Fig. 2822. For the Sides and Tops of Doors.

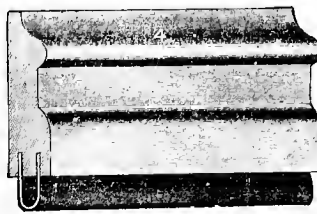

Fig. 2823. For Bottom of Light Doors.

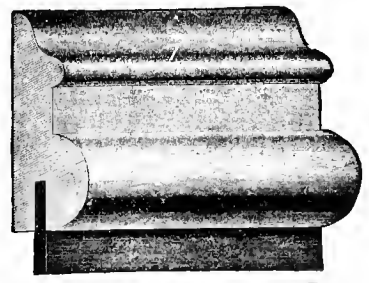

Fig. 2824. For Bottom of Heavy Doors.

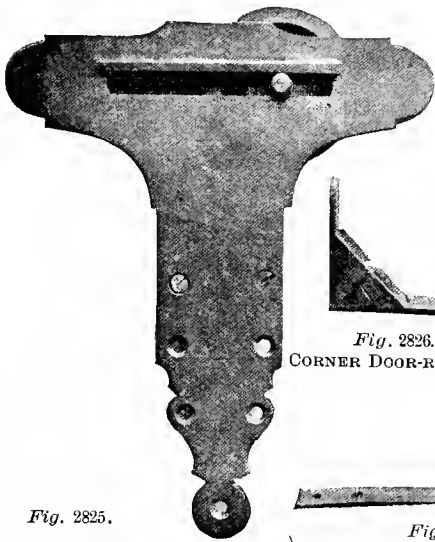

Fig. 2825.

DOOR SHEAVE, IMPROVED NOISELESS.

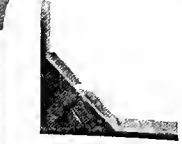

Fig. 2826.
CORNER DOOR-ROLLER.

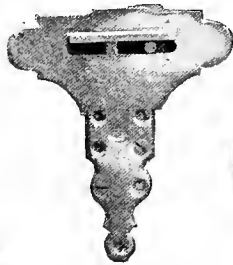

Fig. 2827.
DOOR SHEAVE,
IMPROVED NOISELESS.



Fig. 2828.

DOOR GUIDE.

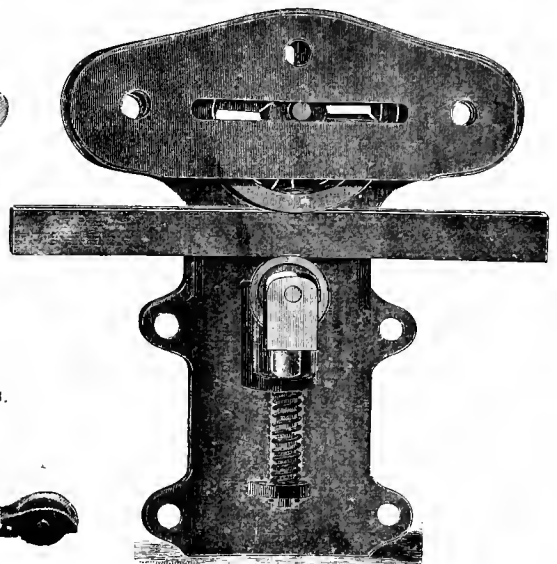

Fig. 2829.
HATFIELD HANGING-DOOR SHEAVE.
(Used for both passenger and freight cars.)

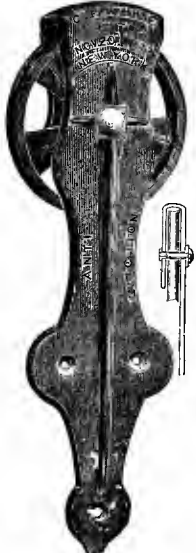

Fig. 2830.
WHITE'S "ANTI-FRICTION"
CAR-DOOR HANGER.

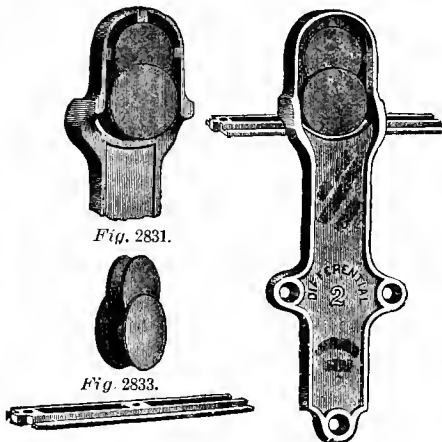

Fig. 2831.
Fig. 2832.
Fig. 2833.
"DIFFERENTIAL" CAR-DOOR HANGER.

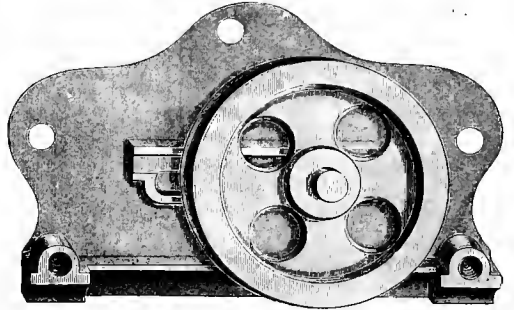

Fig. 2834a.
Side Elevation, with one Side-plate removed.
"ANTI-FRICTION" CAR-DOOR SHEAVE.

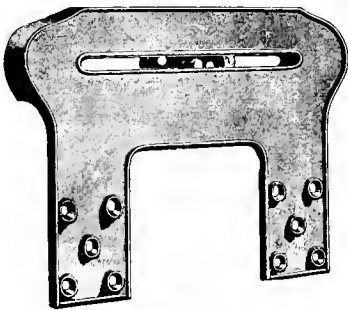

Fig. 2835.

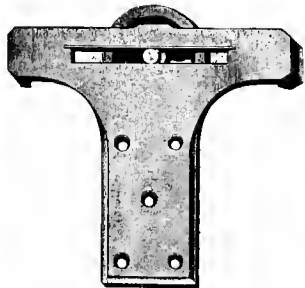

Fig. 2836.

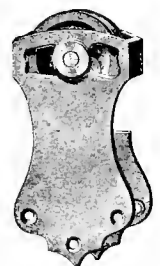

Fig. 2837.

BAGGAGE AND END-DOOR CAR-SHEAVES.

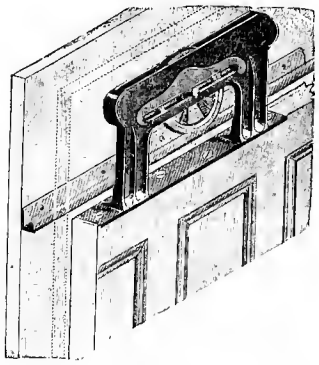

Fig. 2838.

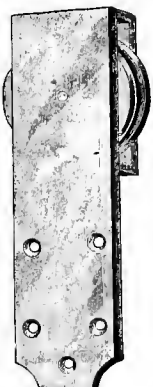

Fig. 2839.

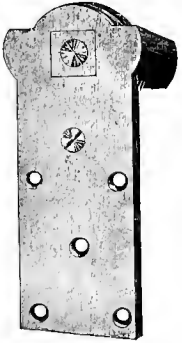

Fig. 2840.

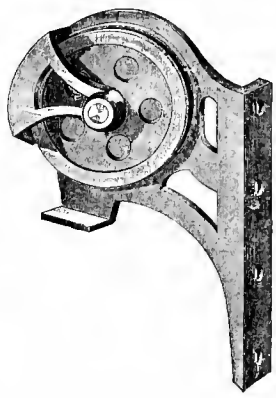

Fig. 2841.

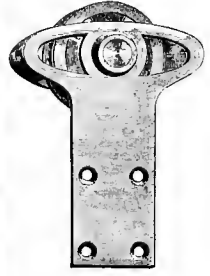

Fig. 2842.

CAR-DOOR SHEAVES.

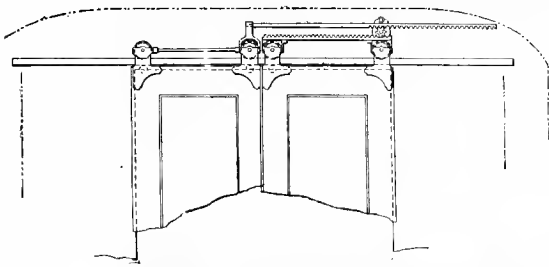

Fig. 2843. DOUBLE SLIDING DOOR FIXTURE.
J. L. HOWARD & Co., HARTFORD, CONN.

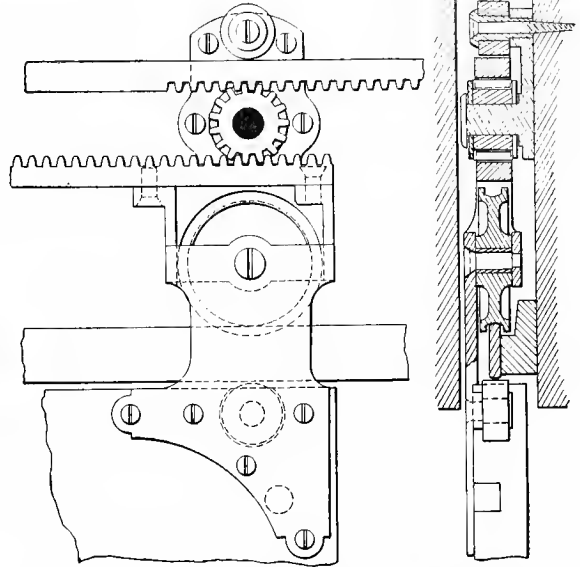

Fig. 2844. Side Elevation. Fig. 2845. Cross Section
DETAILS OF DOUBLE SLIDING-DOOR FIXTURE.

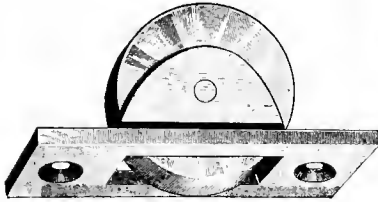

Fig. 2846.
BOTTOM DOOR-ROLLER.

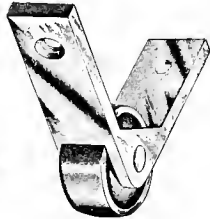

Fig. 2847.
CORNER DOOR-ROLLER.



Fig. 2848. END DOOR-ROLLER.

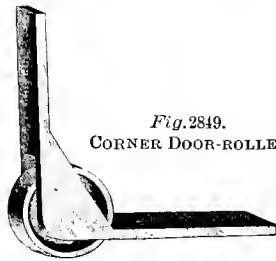

Fig. 2849.
CORNER DOOR-ROLLER.

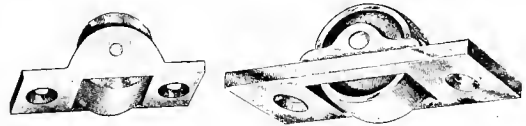

Fig. 2850. BOTTOM DOOR-ROLLER. Fig. 2851. BOTTOM DOOR-ROLLER.

FLOOR-FURNISHINGS.

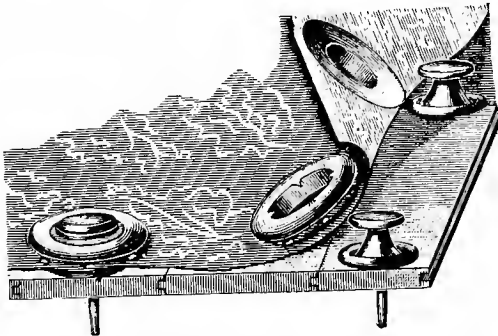

Fig. 2852.
CARPET EYELETS AND NAILS.



Figs. 2853-2854.
UPPER AND LOWER GROMETS FOR CARPET
EYELETS.



Fig. 2855.
WIRE EYELET-NAIL.

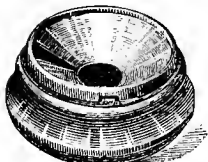

Fig. 2858.
SPITTOON.

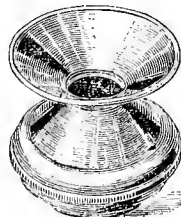

Fig. 2859.
CUSPIDOR.

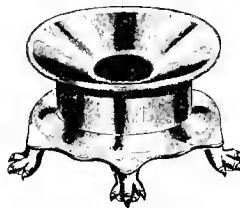

Fig. 2860. CAST SPITTOON.
Larsen's Removable Top.

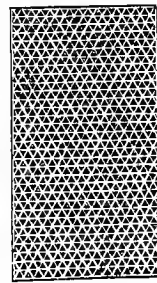

Fig. 2856.
CORRUCOATED-RUBBER
FLOOR-MAT.

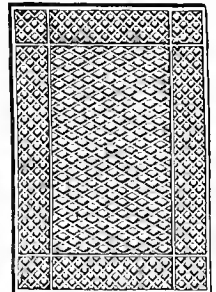

Fig. 2857.
PERFORATED-RUBBER
FLOOR-MAT.



Figs. 2861-2862.
SPITTOON, WITH IRON BAND AND CENTER
(235) SUPPORT.



Fig. 2863.
"PROTECTION" CUSPIDOR, WITH
UMBRELLA-RESTS.

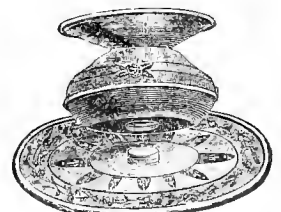

Fig. 2864.
"PROTECTION" CUSPIDOR,
WITH MAT.

HEATERS AND HEATING APPARATUS.



Fig. 2865. Exterior View.

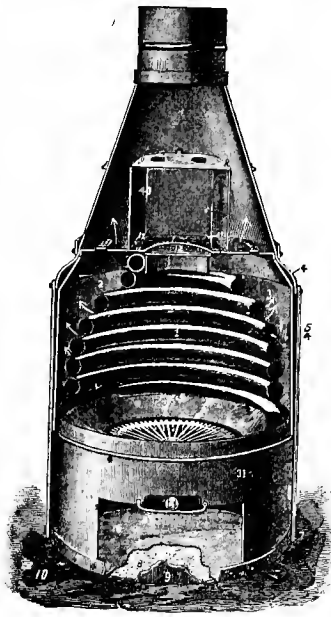

Fig. 2866. Sectional View.
THE "FIRE-PROOF" HEATER.

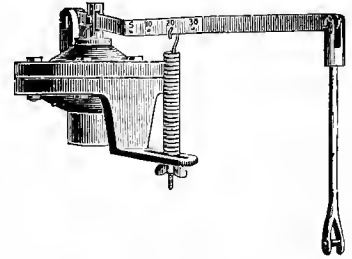

Fig. 2867.
AUTOMATIC FIRE-REGULATOR AND PRESSURE-INDICATOR COMBINED.



Fig. 2868.
DRAFT DOOR AND FRAME.



Fig. 2869.
RING FOR RUSSIA IRON.

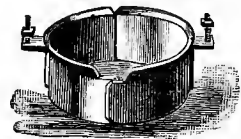

Fig. 2870.
COAL-FEED CHUFF.

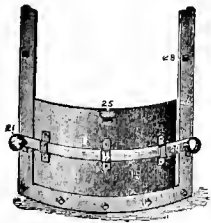

Fig. 2871.
ASH-PIT DOOR FRAME.



Fig. 2872.
REMOVABLE ASH-PAN.

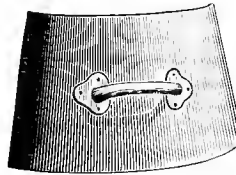

Fig. 2873.
FEED-DOOR.

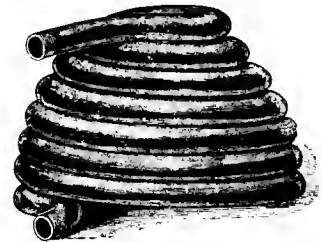

Fig. 2874.
GENERATOR COIL OF 30 CONTINUOUS FEET OF JOINTLESS, EXTRA-HEAVY WROUGHT-IRON PIPE.

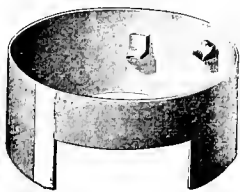

Fig. 2875.
ASH-PIT.

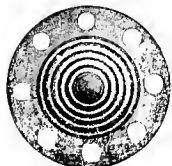

Fig. 2876.
REGULATOR DIAPHRAGM.



Fig. 2877.
SMOKE SCREEN, CAST IRON.



Fig. 2878.
ASH-PIT RING.



Fig. 2880.
GRATE SHAKER.



Fig. 2881.
FIRE GRATE.

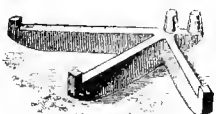

Fig. 2882.
FIRE-GRATE SUPPORT.



Fig. 2883.
SAFETY PLATE AND WOODEN HANDLE.

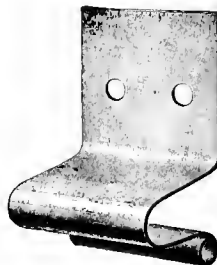

Fig. 2884.
SAFETY-PLATE SPRING.



Fig. 2879.
BASE OF SMOKE-FLUE.



Fig. 2887.
SMOKE-FLUE BASE.



Fig. 2888.
FIRE-POT.

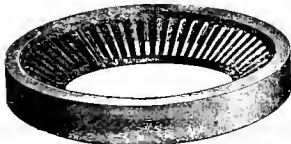

Fig. 2889.
ASH-PIT RING.

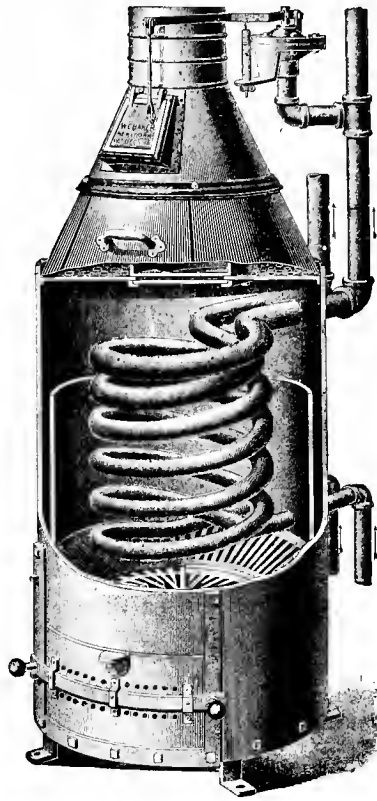

Fig. 2885. Sectional View.

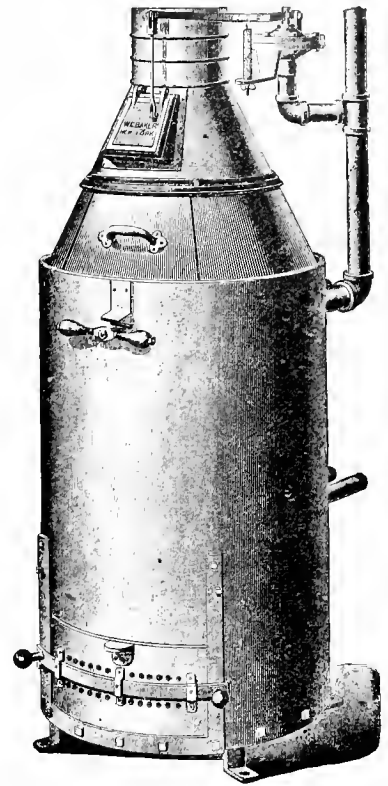

Fig. 2886. Exterior View.

IMPROVED TWO-COIL FIRE-PROOF HEATER.

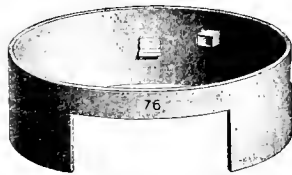

Fig. 2890.
ASH-PIT.

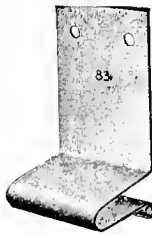

Fig. 2891.
SAFETY-PLATE SPRING.

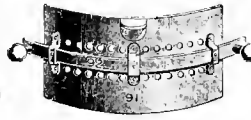

Fig. 2892.
ASH-PIT DOOR.



Fig. 2893.
CIRCULATING DRUM.



Fig. 2893a.
FIRE-GRATE.



Fig. 2893b.
FIRE-GRATE SUPPORT.



Fig. 2893c.
DRAFT-DOOR AND FRAME.



Fig. 2893d.
GRATE-SHAKER.



Fig. 2893e.
RING FOR RUSSIA-IRON TOP.

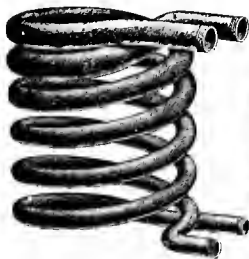

Fig. 2894.
DOUBLE EXPANDING GENERATOR
COIL.

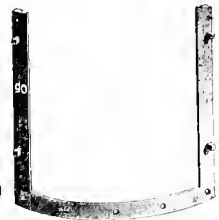

Fig. 2895.
ASH-PIT DOOR
FRAME.



Fig. 2896.
SAFETY-PLATE
GUIDES.



Fig. 2897.
FEED-DOOR.

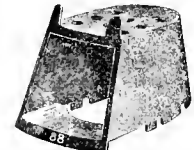

Fig. 2898.
SMOKE SCREEN, REMOVABLE
FOR CLEANING OF HEATER.



Fig. 2899.
SAFETY-PLATE AND HANDLE.



Fig. 2900.
ASH-PAN, REMOVABLE.

BAKER'S TWO-COIL FIRE-PROOF CAR-HEATER, AND PARTS SPECIALLY BELONGING TO IT.

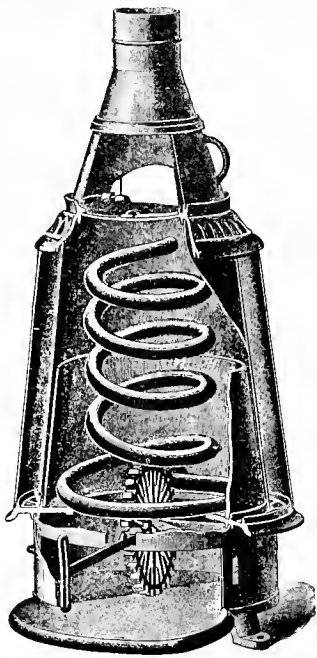

Fig. 2901. Sectional View. THE "PERFECTED" HEATER.

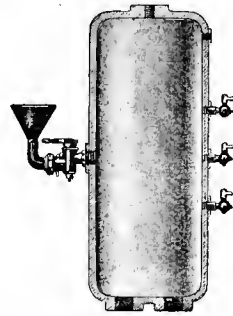

Fig. 2902. UPRIGHT CIRCULATING DRUM TO GO INSIDE OF CAR.



Fig. 2902a. RING FOR RUSSIA IRON TOP.



Fig. 2903. CIRCULATING DRUM, OR WATER RESERVOIR AND EXPANSION CHAMBER.



Fig. 2904. BASE OF SMOKE-FLUE.

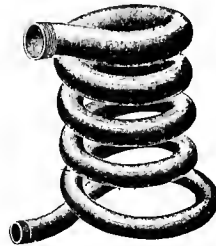

Fig. 2906. EXPANDING GENERATOR COIL.



Fig. 2907. GENERATOR COIL.



Fig. 2908. OUTSIDE CASING, REMOVABLE.

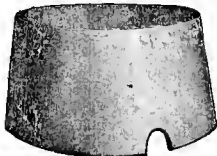

Fig. 2909. HIGH FIRE-POT, CAST WHOLE.



Fig. 2910. ASH-PIT.



Fig. 2911. ASH-PIT TOP (NO. 28), GRATE (NO. 30) AND DOOR (NO. 31).



Fig. 2912. TOP OF HEATER AND PART OF GAS PREVENTOR.



Fig. 2913. ASH-PIT BOTTOM AND BROAD HEARTH.

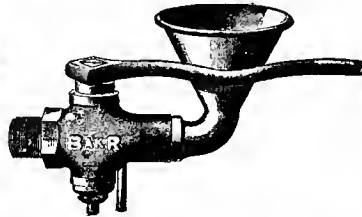

Fig. 2914. FILLING FUNNEL AND COMBINATION COCK WITH DRIFT.

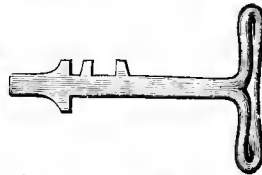

Fig. 2918. GRATE SHAKER.

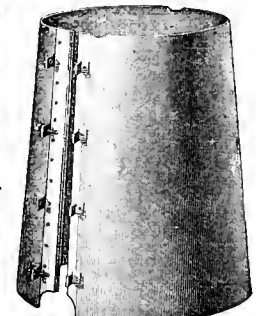

Fig. 2916. INSIDE CASING REMOVABLE.

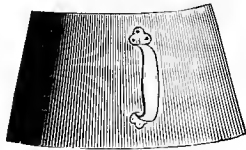

Fig. 2913a. FEED DOOR.



Fig. 2912a. SAFETY LATCH.

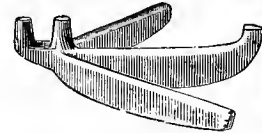

Fig. 2915. GRATE-SUPPORT.

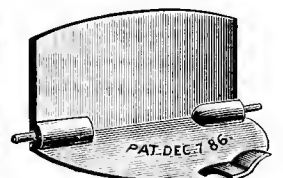

Fig. 2917. SAFETY PLATE AND GAS PREVENTOR COMBINED.

Fig. 2919b. BASE OF SMOKE-FLUE.

Fig. 2919c. FEED DOOR.



Fig. 2919. SECTIONAL VIEW.

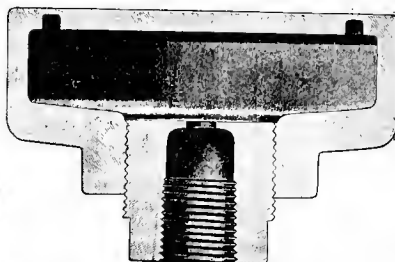
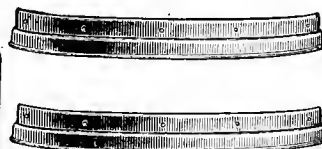

Fig. 2919a. CROSS SECTION OF CAST-IRON SAFETY-VENT AND BUSHING. May be used on all Heaters.



Figs. 2919d-e. ASH-PIT DOOR-GUIDES.



Fig. 2920. COIL.



Fig. 2921. TOP OF HEATER.



Fig. 2921a. ASH-PIT BOTTOM.

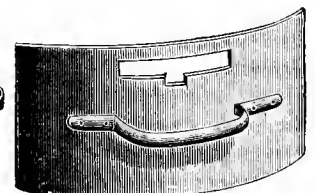

Fig. 2922. DOOR OF ASH-PIT.

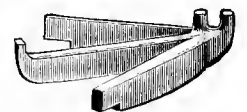

Fig. 2923. GRATE-SUPPORT.

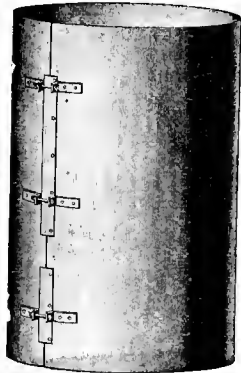

Fig. 2924. Outside Case. MIGHTY MIDGET HEATER.

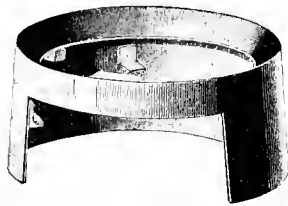

Fig. 2925. Ash-pit.

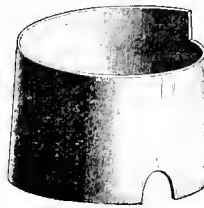

Fig. 2926. Fire-pot.



Fig. 2927. Pet-cock.



Fig. 2927a. Safety-latch.



Fig. 2928. Four-pipe Strap.

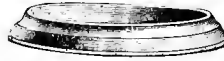

Figs. 2929bc. Rings for Russia-top of "Mighty Midget."



Fig. 2929a. Special. Wrought-iron Pipe. 2 1/4 to 3 lb. per foot.



Fig. 2929. Back for 4-pipe Strap.



Fig. 2933. Drum Cover.



Fig. 2934. Plug.



Fig. 2935. Two-pipe Strap and Back.



Fig. 2936. Single pipe Strap.



Fig. 2930. Safety-valve.



Fig. 2931. Ball for Safety-valve.

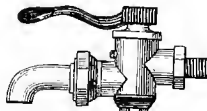

Fig. 2932. Combination Cock.

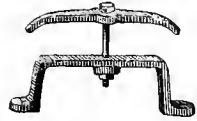

Fig. 2937. Stand for Open Return-bend Radiator.



Fig. 2937a. Radiator-stand.



Fig. 2938. Pipe and Radiator support.



Fig. 2939. Filling-funnel.



Fig. 2940. Return Bend.

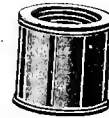

Fig. 2941. Coupling.



Fig. 2942. Reducing Coupling.

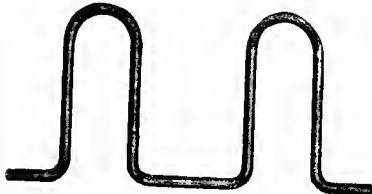

Fig. 2943. Double Radiator, to go under seats.



Fig. 2944. Radiator, to go under seats.



Fig. 2945. Return Bend.



Fig. 2946. Return Bend.

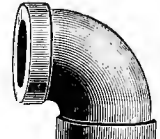

Fig. 2947. Elbow.

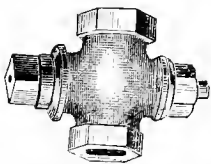

Fig. 2948. Stop cock.



Fig. 2949. Tee.



Fig. 2950. Tee.

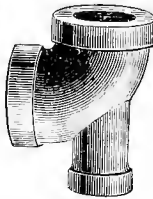

Fig. 2951. Ell, with outlet.



Fig. 2952. Nipple.

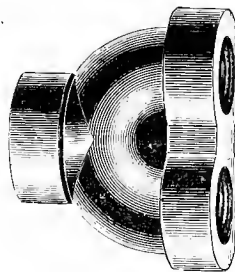

Fig. 2953. Return Bend, three-way.



Fig. 2954. Close Nipple.



Fig. 2955. Bushing.



Fig. 2956. 45° Elbow.

GENERAL FITTINGS AND SPECIAL PARTS, BAKER HEATING APPARATUS.

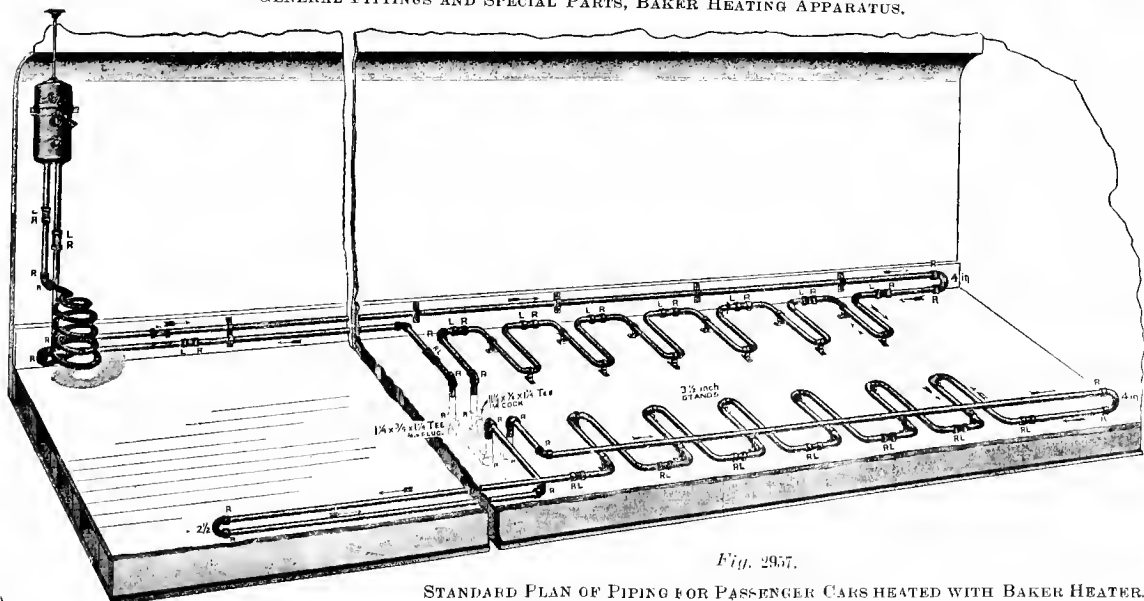

Fig. 2957.

STANDARD PLAN OF PIPING FOR PASSENGER CARS HEATED WITH BAKER HEATER.

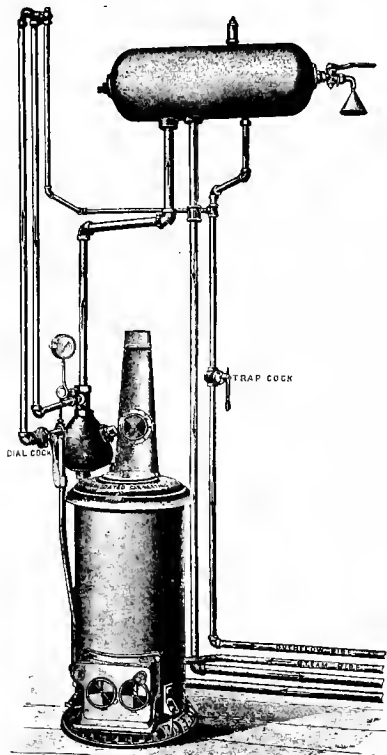

Fig. 2969. McELROY COMMINGLER SYSTEM OF CAR HEATING

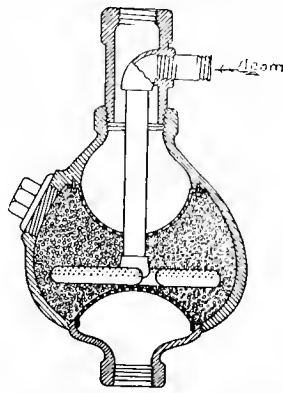

Fig. 2970. THE McELROY COMMINGLER.

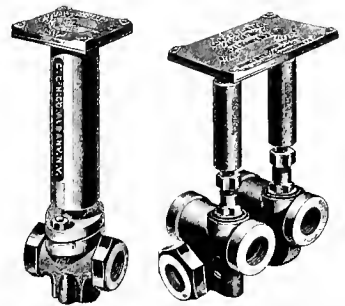

Fig. 2971. SPECIAL ASBESTOS-COCK. Fig. 2972. MAIN STEAM-CASTING.

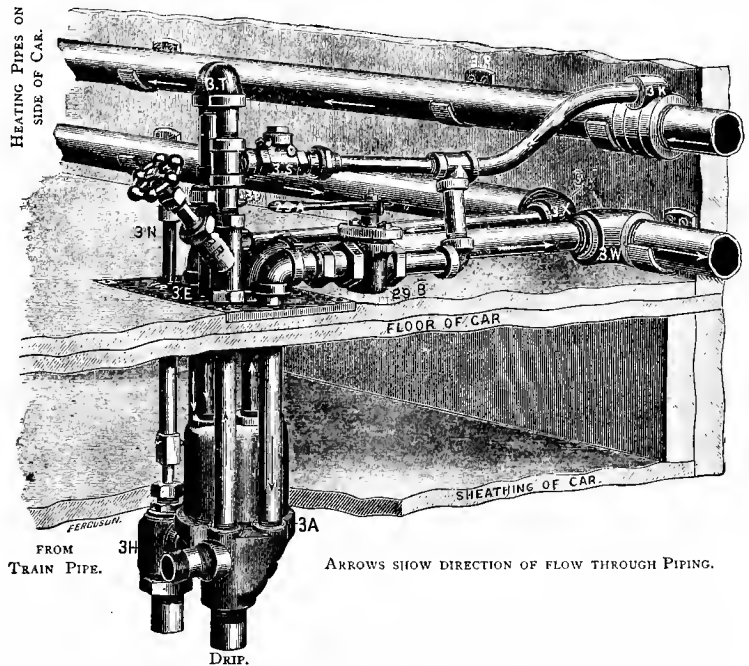

Fig. 2973. THE COMMINGLER STORAGE SYSTEM.

NAMES OF PARTS. Fig. 2974.

- | | | |
|---|------------------------|--|
| A. Coil. | B. McElroy Commingler. | F. McElroy Steam-gauge to show pressure on train-pipe. |
| C. Dial Cock for admitting Steam to Commingler B. | | G. Swing Check-valve. |
| D. Trap for opening Overflow-pipe H. | | H. Overflow-pipe to remove Water of Condensation. |
| E. Water Line in Expansion-drum. | | |

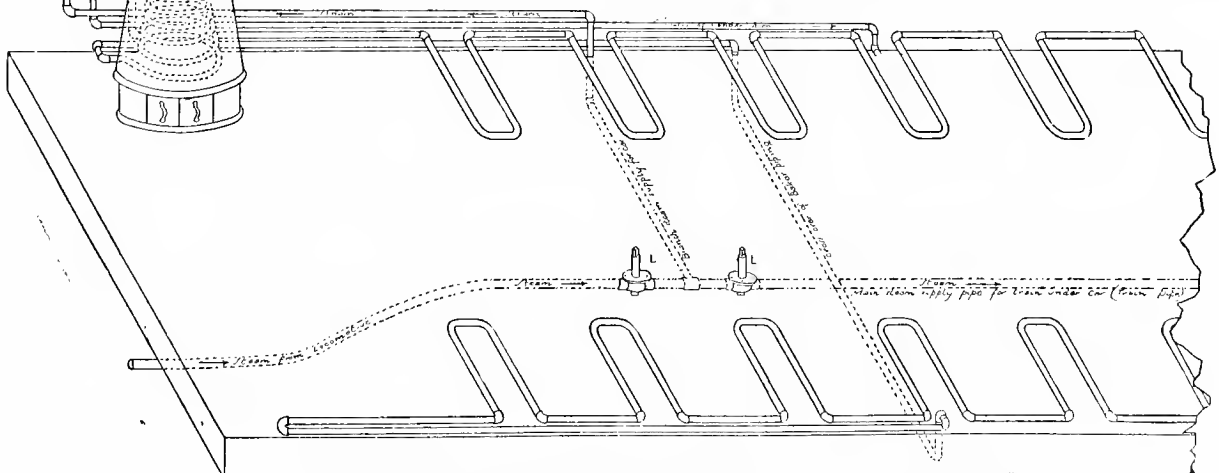
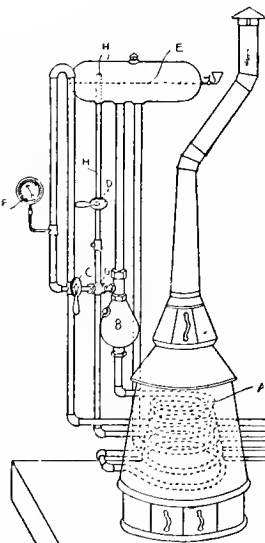

Fig. 2974. Perspective View.

A SYSTEM OF PIPING FOR COMMINGLER SYSTEM OF HEATING IN CONNECTION WITH HOT-WATER SYSTEM.



Fig. 2979.
DIAL-COCK.

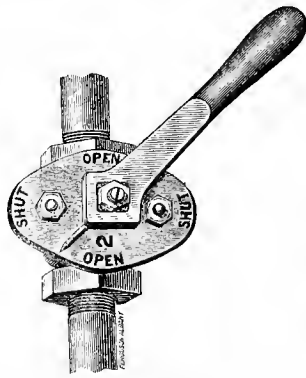

Fig. 2980. Elevation.

TRAP-COCK.

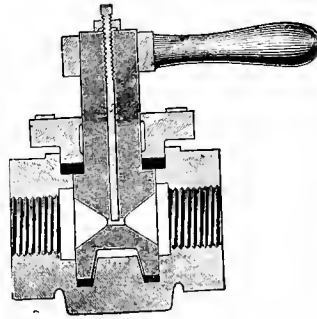

Fig. 2981. Section.

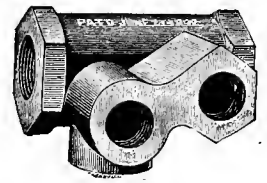

Fig. 2982.
TEE WITH DROP-CONNECTIONS.



Fig. 2983.
ANGLE COCK.



Fig. 2984.
RETURN BEND.

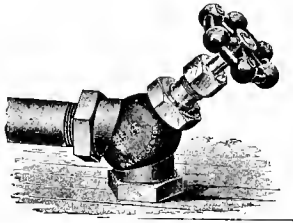

Fig. 2975.
GRADUATING VALVE.



Fig. 2976.
TRAP VALVE.



Figs. 2977-2978
CORRUGATED COPPER TUBES.

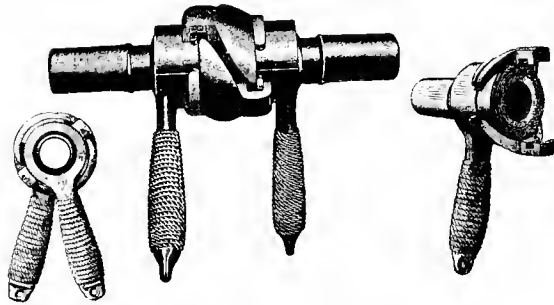

Figs. 2985-2987.
THE McELROY STEAM-HOSE COUPLING.



Fig. 2988.
THE McELROY STEAM-HOSE COUPLING.

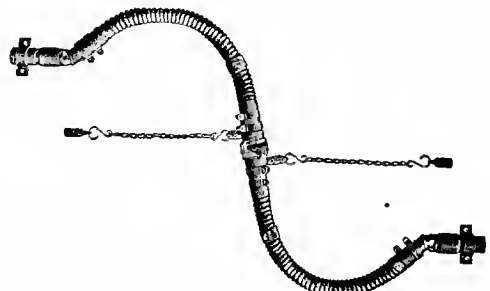

Fig. 2989. THE McELROY STEAM-HOSE COUPLING.



Fig. 2990. (Uncoupled.)

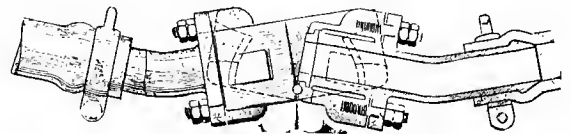

Fig. 2993. Outline Sketch.

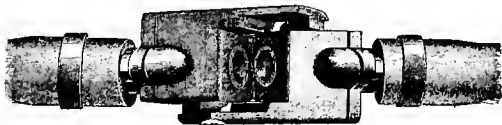

Fig. 2991. (Coupling.)

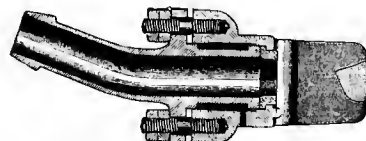

Fig. 2994. Longitudinal Section.



Fig. 2992. (Coupled.)

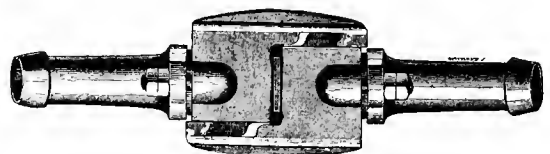

Fig. 2995. Top View.

THE SEWALL STEAM-HOSE COUPLING.

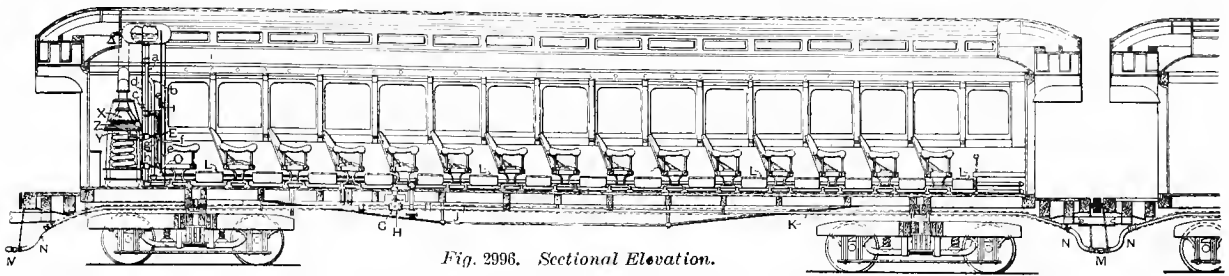

Fig. 2996. Sectional Elevation.

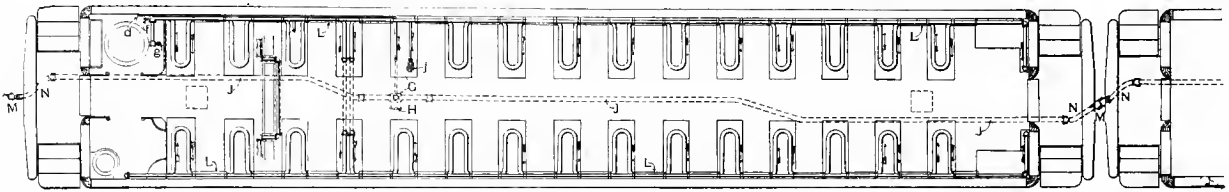

Fig. 2997. Plan of Car, showing System of Pipes.
GOLD'S DOUBLE-COIL HOT-WATER CIRCULATING SYSTEM OF CAR HEATING.

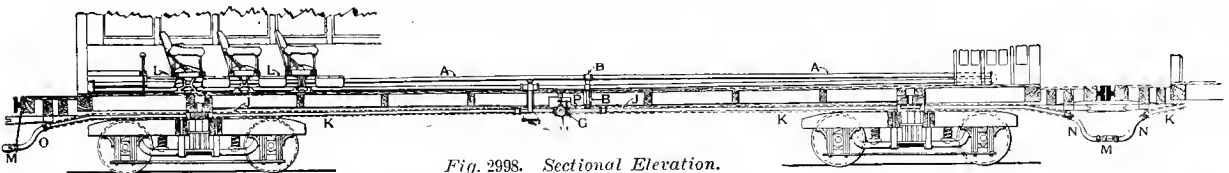

Fig. 2998. Sectional Elevation.

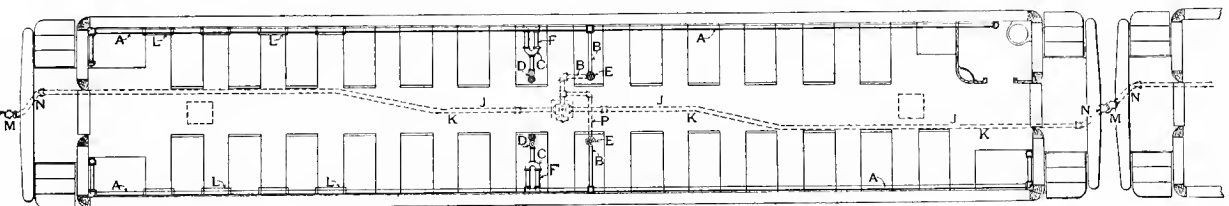

Fig. 2999. Plan of Car, showing System of Piping.
GOLD'S PLAIN PIPE SYSTEM OF CAR HEATING.

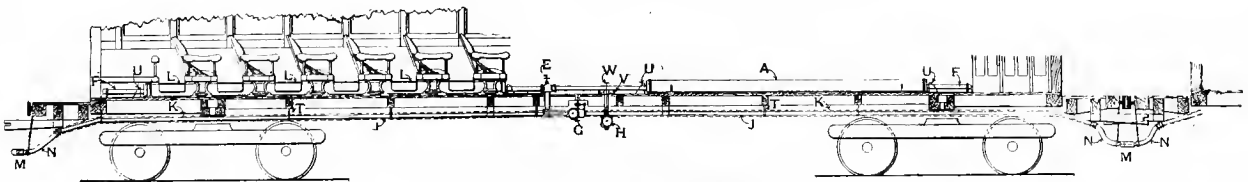

Fig. 3000. Sectional Elevation.

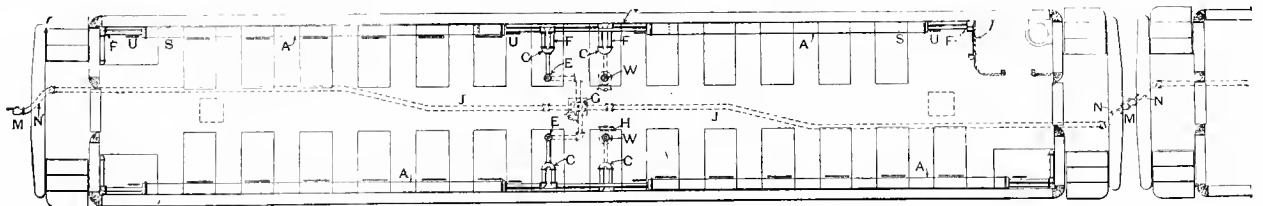
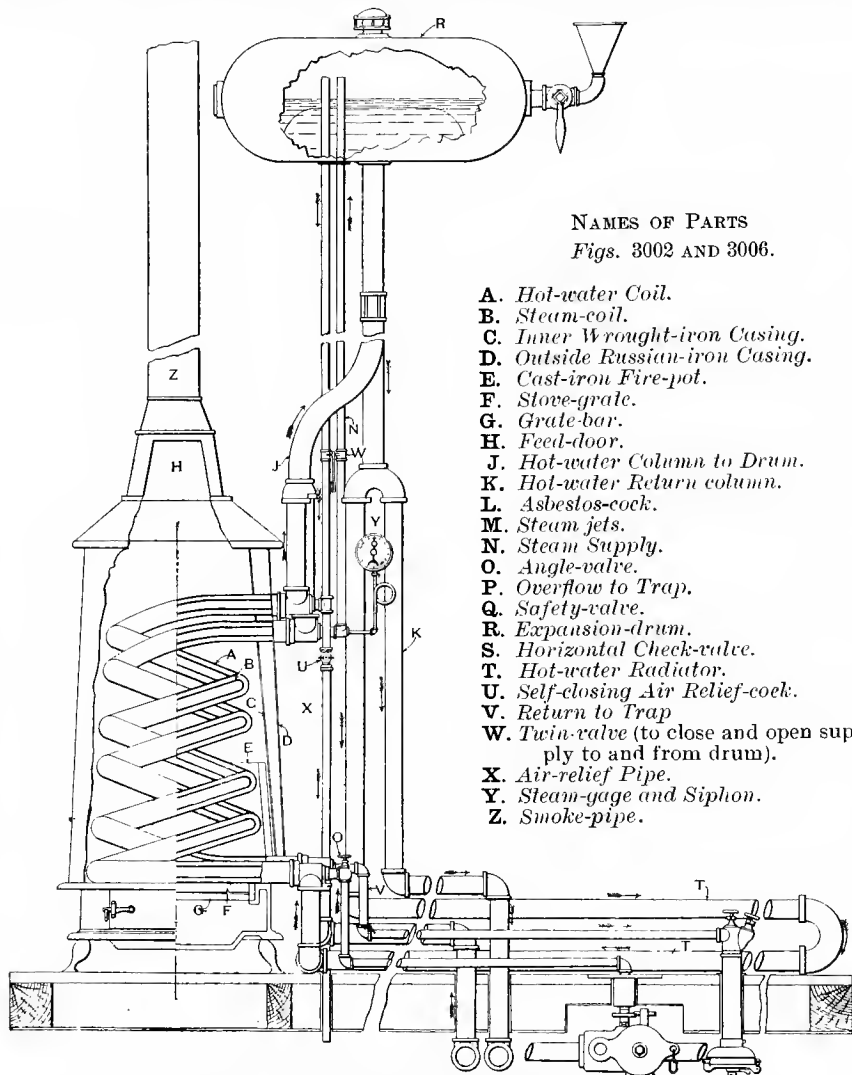

Fig. 3001. Plan of Car, showing System of Piping.
GOLD'S STEAM HEAT STORAGE SYSTEM OF CAR HEATING.

NAMES OF PARTS OF GOLD HEATING SYSTEMS. Figs. 2996-3001.

- | | | | |
|---|------------------------------------|---|----------------------------------|
| A. Heater-pipes. | J. Train-pipe. | U. Cast-iron Heater-stops. | b. Hot-water Column to Radiator. |
| B. Steam Connection. | K. Covering on Train-pipe. | V. Branch-connections to Heater. | c. Asbestos-cock. |
| C. Return-bend. | L. Shields. | W. Wheel and Rod connecting with Sediment-well. | d. Overflow-pipe. |
| D. Gold's Vertical Steam-traps. | M. Couplings. | X. Hot-water Stove. | e. Steam-supply. |
| E. Angle-valve for Steam Supply. | N. Steam-hose. | Y. Hot-water Coil. | f. Check-valve. |
| F. Expansion-loops. | O. Tee. | Z. Steam-coil. | g. Steam-supply to Jet. |
| G. Train-pipe Valve. | P. Cross-over Steam Supply-pipe. | a. Hot-water Column to Drum. | h. Hot-water Return. |
| H. Thermostatic-trap on Train-pipe Valve. | S. Heater-stands. | | i. Steam-jet. |
| | T. Supports for Pipes, Traps, etc. | | j. Improved Trap and Blow-off. |



NAMES OF PARTS
Figs. 3002 AND 3006.

- A. Hot-water Coil.
- B. Steam-coil.
- C. Inner Wrought-iron Casing.
- D. Outside Russian-iron Casing.
- E. Cast-iron Fire-pot.
- F. Stove-grate.
- G. Grate-bar.
- H. Feed-door.
- J. Hot-water Column to Drum.
- K. Hot-water Return column.
- L. Asbestos-cock.
- M. Steam jets.
- N. Steam Supply.
- O. Angle-valve.
- P. Overflow to Trap.
- Q. Safety-valve.
- R. Expansion-drum.
- S. Horizontal Check-valve.
- T. Hot-water Radiator.
- U. Self-closing Air Relief-cock.
- V. Return to Trap
- W. Twin-valve (to close and open supply to and from drum).
- X. Air-relief Pipe.
- Y. Steam-gage and Siphon.
- Z. Smoke-pipe.

Fig. 3002. Sectional View of Heater and Pipe Connections.
DUPLIX DOUBLE-COIL OVERFLOW SYSTEM.

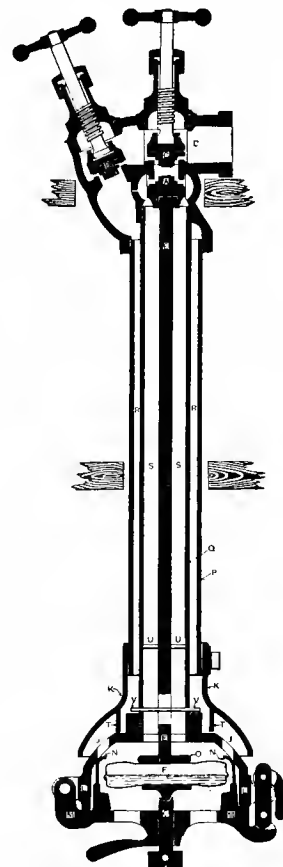
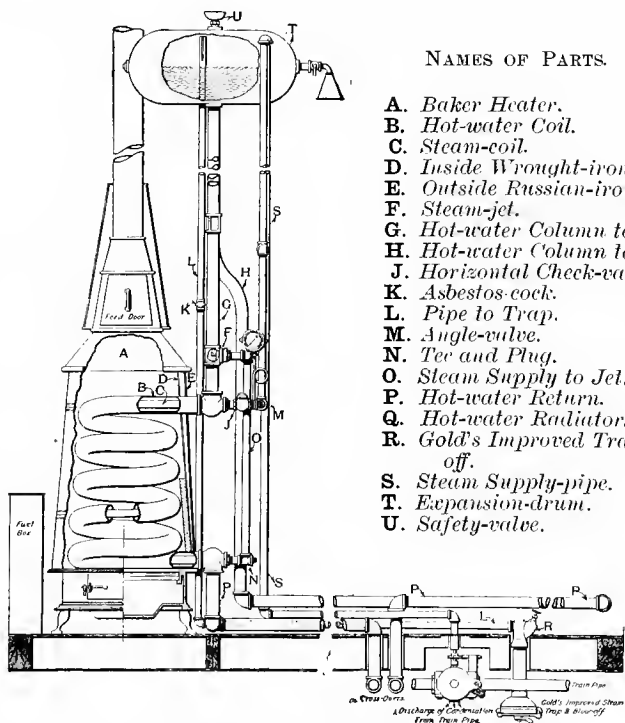

Fig. 3004. Section through Center.

IMPROVED VERTICAL STEAM-TRAP AND BLOW-OFF.



NAMES OF PARTS. Fig. 3003.

- A. Baker Heater.
- B. Hot-water Coil.
- C. Steam-coil.
- D. Inside Wrought-iron Casing.
- E. Outside Russian-iron Casing.
- F. Steam-jet.
- G. Hot-water Column to Drum.
- H. Hot-water Column to Radiator.
- J. Horizontal Check-valve.
- K. Asbestos-cock.
- L. Pipe to Trap.
- M. Angle-valve.
- N. Tee and Plug.
- O. Steam Supply to Jet.
- P. Hot-water Return.
- Q. Hot-water Radiator.
- R. Gold's Improved Trap and Blow-off.
- S. Steam Supply-pipe.
- T. Expansion-drum.
- U. Safety-valve.

Fig. 3003. Sectional View of Heater and Pipe Connections.

DOUBLE-COIL JET SYSTEM.

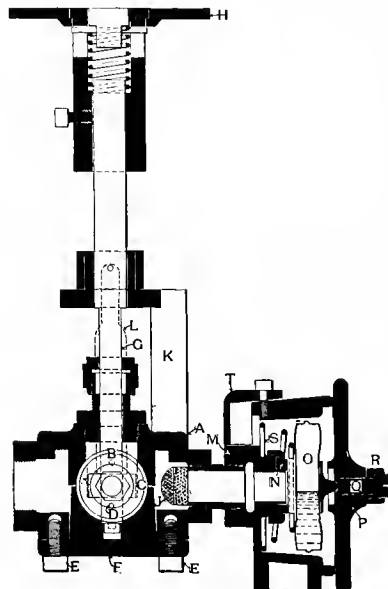
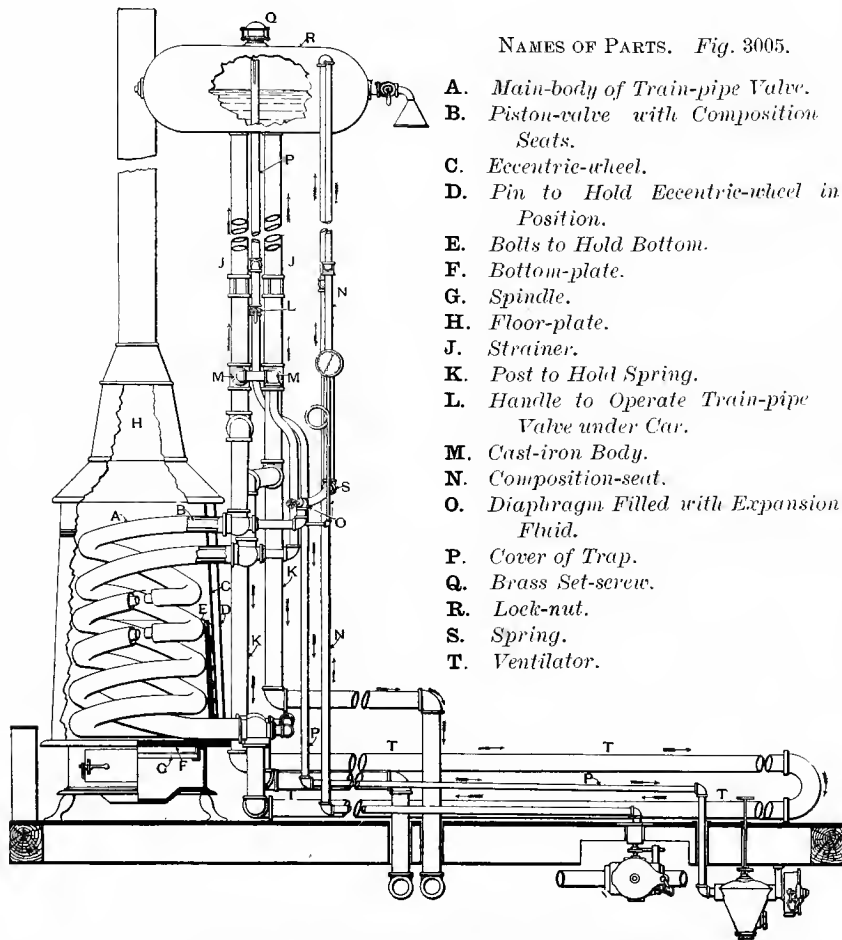

Fig. 3005. Section through Center.

TRAIN-PIPE VALVE, WITH THERMOSTATIC STEAM-TRAP.

Letters refer to List of Names on Preceding Page.



- NAMES OF PARTS. Fig. 3005.
- A. Main-body of Train-pipe Valve.
 - B. Piston-valve with Composition Seats.
 - C. Eccentric-wheel.
 - D. Pin to Hold Eccentric-wheel in Position.
 - E. Bolts to Hold Bottom.
 - F. Bottom-plate.
 - G. Spindle.
 - H. Floor-plate.
 - J. Strainer.
 - K. Post to Hold Spring.
 - L. Handle to Operate Train-pipe Valve under Car.
 - M. Cast-iron Body.
 - N. Composition-seat.
 - O. Diaphragm Filled with Expansion Fluid.
 - P. Cover of Trap.
 - Q. Brass Set-screw.
 - R. Lock-nut.
 - S. Spring.
 - T. Ventilator.

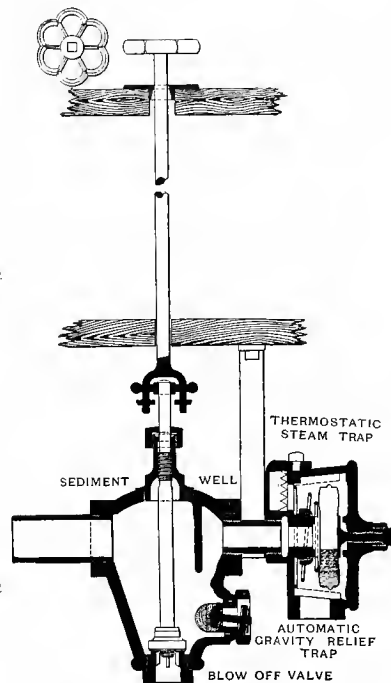

Fig. 3007
EXCELSIOR STEAM TRAP WITH SEDIMENT WELL, GRAVITY RELIEF TRAP AND SPECIAL BLOW-OFF VALVE.

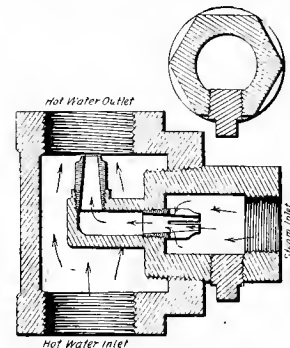

Fig. 3008. Section through Center. GOLD'S STEAM-JET.

Fig. 3006. Sectional View of Heater and Pipe Connections. DUPLEX DOUBLE-COIL JET SYSTEM WITH SEDIMENT WELL AND SPECIAL BLOW-OFF.

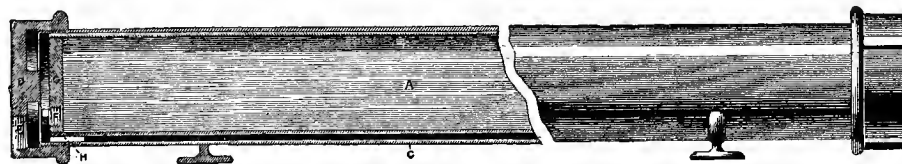

Fig. 3009 Sectional Elevation. GOLD'S STORAGE HEATER (Iron).

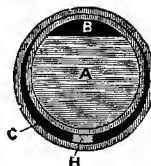

Fig. 3010 Cross Section.

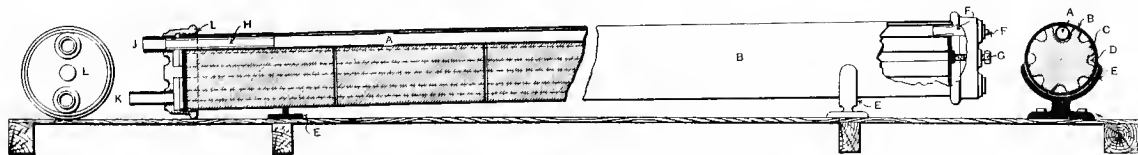

Fig. 3010. GOLD'S TERRA-COTTA STORAGE HEATER.

- NAMES OF PARTS. Fig. 3010.
- A. Supply-pipe.
 - B. Outside-tube.
 - C. Section of Terra-cotta.
 - D. Ports or Passage for Steam and Condensation.
 - E. Heater Support.
 - F. Plug for 1 in. Supply Pipe.
 - G. Lock Nut and Plate.
 - H. Steam Pipe to Pipe "A."
 - J. Supply-pipe.
 - K. Return.
 - L. Heater-cap.

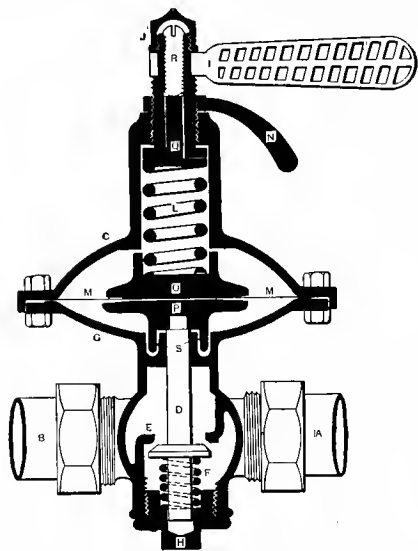

Fig. 3011. Longitudinal Section.

NAMES OF PARTS. Fig. 3004.

- A. Seat of Automatic-trap.
- B. Blow-off.
- C. Valve for Cutting out Automatic-trap.
- D. Strainer to Protect Automatic Trap-seat.
- E. Valve-stem for Operating Automatic-trap.
- F. Diaphragm for Operating Automatic-trap and Containing Expansive Fluid.
- G. Set-screw for Adjusting Automatic-trap.
- J. Holes (to Ventilate Casing Containing Diaphragm).
- K. Shields to Prevent Water from Flying Horizontally.
- L. Cast-iron Casing Containing Expansive-diaphragm.
- M. Hinged Cover to Trap-casing.
- N. Diaphragm-guard.
- O. Plate on End of Valve Stem to rest on Diaphragm.
- P. 2-inch Pipe.
- Q. 1½-inch Pipe.
- R. Passage for Blow-off.
- S. Passage for Discharge from Automatic-trap.
- T. Posts to Support Shield-guard (K).
- U. Guides for Valve-stem (E).
- V. Split-key (to Prevent Valve from Falling Out when Cover M is Removed).

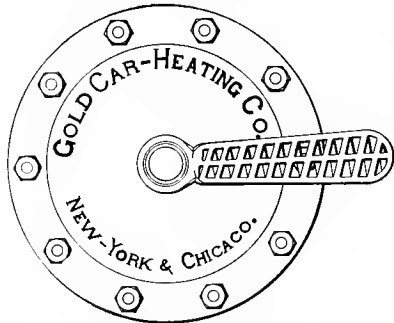

Fig. 3012. Plan.
GOLD'S PRESSURE REGULATOR.

NAMES OF PARTS. Figs. 3011-3012.

- A. Steam-inlet.
- B. Steam-outlet.
- C. Regulator-body.
- D. Regulator-valve.
- E. Valve-seat.
- F. Valve-spring.
- G. Valve-body.
- H. Valve-plug.
- I. Handle.
- J. Handle-nut.
- L. Regulator-spring.
- M. Diaphragm.
- N. Lock-nut Handle.
- O. Diaphragm-flange, Top.
- P. Diaphragm-flange, Bottom.
- Q. Spring-cap and Guide.
- R. Spring Adjusting-screw.
- S. Water-seat.



Fig. 3013. Coupled.

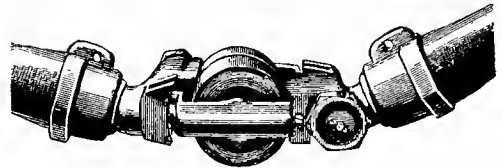

Fig. 3016.
GOLD'S COMPRESSION COUPLING.



Fig. 3014. Uncoupled.

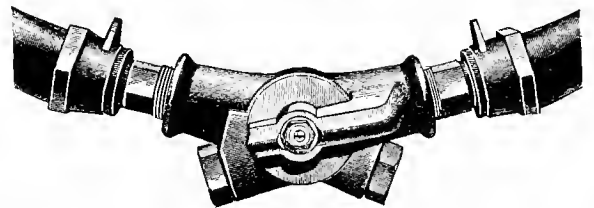

Fig. 3017.
GOLD'S INTERCHANGEABLE COUPLING.



Fig. 3015. Act of Coupling.
THE UNIVERSAL STRAIGHT PORT COUPLING.

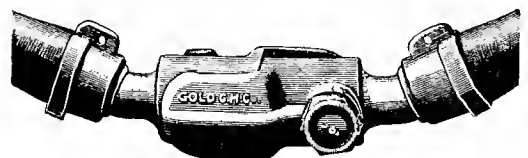

Fig. 3018.
THE UNIVERSAL STRAIGHT PORT COUPLING.

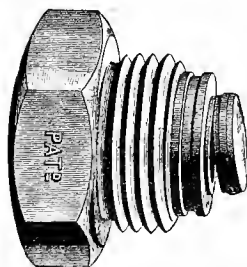

Fig. 3019. Perspective View.

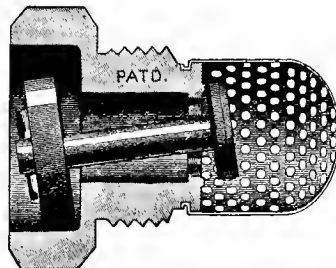

Fig. 3020. Sectional View.
GOLD'S GRAVITY RELIEF TRAP.

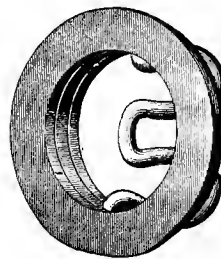

Fig. 3021.

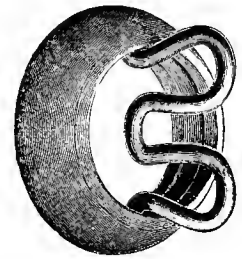

Fig. 3022.

GASKETS FOR GOLD STRAIGHT-PORT COUPLING.

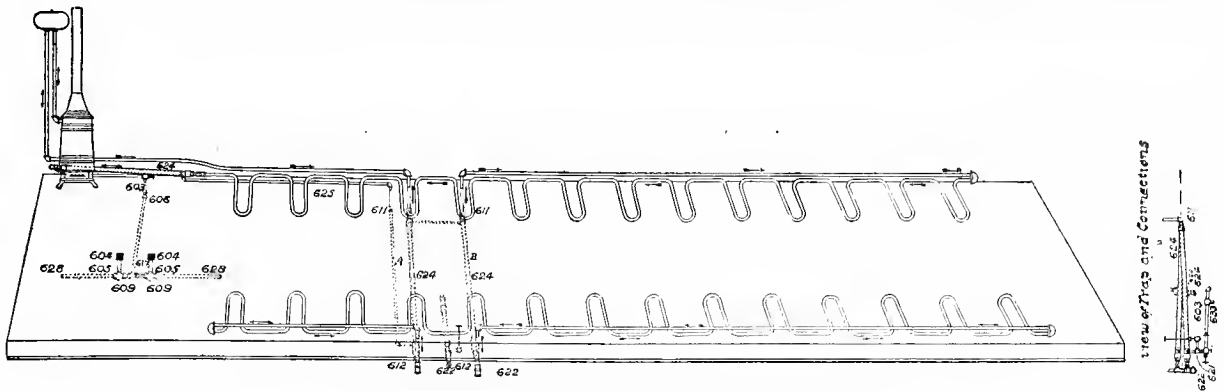

Fig. 3023. General View of Heater and Connections.

STANDARD SYSTEM OF STEAM HEATING BY SINGLE WATER CIRCULATION (L-50).

Water is Heated in Jackets (No. 624) Shown in Figs. 3051-3055.

NAMES OF PARTS CONSTITUTING ONE EQUIPMENT. Fig. 3023.

- | | | |
|--|---|--|
| 603. Steam Valve (Special) (2). | 617. Tee, $1\frac{1}{2} \times 1$ in. (1). | 629. $\frac{3}{4}$ x Heavy Nipple (2). |
| 604. Floor-plate (2). | 618. Coupling, $1\frac{1}{2}$ in., R. x L. (2). | 633. Trap Complete (1). |
| 605. Socket (2). | 619. Handle for Valve (1). | 639. Directions, Framed (1). |
| 606. Wrench (1). | 619a. Floor-plate, Drip (1). | 642. Plug, 1 in. (6). |
| 609. Train-pipe Cock (2). | 621. Tee, 1 in. (1). | 677. } Coverings for outside pipes, |
| 611. Ell, $1\frac{1}{2}$ in. (2). | 622. $\frac{3}{4}$ x Heavy Cock (2). | 678. } tees and ells. |
| 612. Tee, $1\frac{1}{2} \times \frac{3}{4} \times 1\frac{1}{2}$ in. (2). | 624. Jackets (3). | 679. } |
| 616. Ells, 1 in. (6). | 625. Pipe, 1 in. (40 ft.). | 698. Nipple, $1\frac{1}{2}$ in. x 3 in. (2). |
| 616. Ells, 1 in. R. x L. (3). | 626. Pipe, $1\frac{1}{2}$ x Strong (10 ft.). | 699. Street Ell, 1 in. (2). |
| | 628. Pipe, $1\frac{1}{2}$ in. (60 ft.). | |

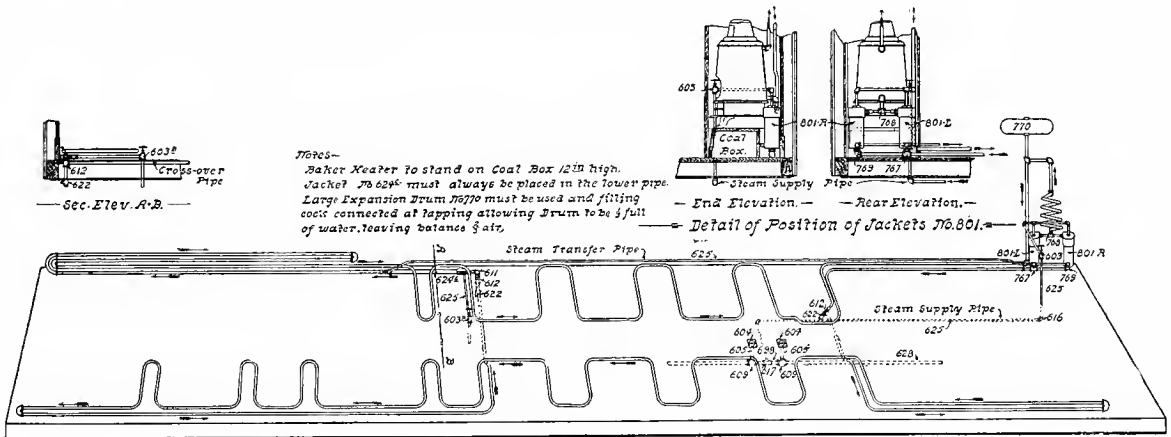

Figs. 3024-3027.

STANDARD (COIL JACKET) HEATING SYSTEM (L-113).

THE SAFETY CAR HEATING AND LIGHTING COMPANY.

NAMES OF PARTS CONSTITUTING ONE EQUIPMENT. Figs. 3024-3027.

- | | | |
|--|--|---|
| 603. 1 in. Angle-valve (Special) (1). | 618. Couplings, R. and L., $1\frac{1}{2}$ in. (2). | 677. Covering for $1\frac{1}{2}$ in. Pipe (60 ft.) |
| 603b. 1 in. Angle Drip-valve (1). | 621. Tees, 1 in. (2). | 679. Covering for $1\frac{1}{2}$ in. Tees (3). |
| 604. Floor-plate for Train-pipe
Cocks (2). | 622. $\frac{3}{4}$ in. Extra Heavy Cock (2). | 680. Covering for 1 in. Pipe (18 ft.). |
| 605. Socket for Train-pipe Cocks (2). | 624c. One-pipe Jacket (1). | 681. Covering for 1 in. Ell (2). |
| 606. Wrench for Train-pipe Cocks (1). | 625. Standard Pipe, 1 in. (40 ft.). | 698. Nipples, $1\frac{1}{2} \times 3$ in. (2). |
| 609. Asbestos Packed Train-pipe
Cock with Drip, $1\frac{1}{2}$ in. (2). | 626. Extra Strong Pipe, $1\frac{1}{2}$ in. (20 ft.). | 699. Street Ells, 1 in. (2). |
| 616. Ells, 1 in. (4). | 628. Standard Pipe, $1\frac{1}{2}$ in. (60 ft.). | 767. $1\frac{1}{2} \times 1\frac{1}{2} \times 1$ in. Tee (1). |
| 616a. Ells, R. and L., 1 in. (4). | 629. Extra Heavy Nipple, $\frac{3}{4}$ in. (2). | 768. $1 \times 1 \times 1\frac{1}{2}$ in. Tee (1). |
| 617. Tee, $1\frac{1}{2} \times 1$ in. (1). | 631. Couplings, 1 in., R. and L. (6). | 769. $1\frac{1}{2} \times 1$ in. Ell (1). |
| (247) | 639. Directions (frame) (1). | 770. Expansion-drum, 3 ft. (1). |
| | 642. Plugs, 1 in. (2). | 801. Coil-jacket (1 Pr.). |

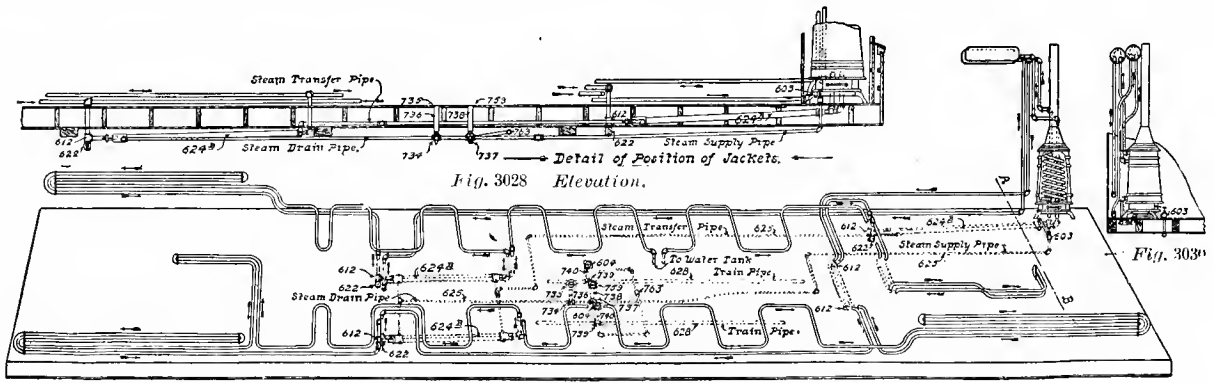

Fig. 3029. Plan.

STANDARD (RETURN) HEATING SYSTEM (L-145).

NAMES OF PARTS, CONSTITUTING ONE EQUIPMENT. Figs. 3028-3030.

- | | | |
|--|--|---|
| 603. Angle Valve, 1 in. (1). | 628. Standard Pipe, 1½ in. (120 ft.). | 737. Four-way Cock (left hand threads) 1 in. (1). |
| 604. Floor-plates for Train-pipe Cock (2). | 629. Extra Heavy Nipple, ¾ in. (6). | 738. Socket for Four-way Cock (1). |
| 606. Wrench for Train-pipe Cock (1). | 631. Couplings, R. and L., 1 in. (8). | 739. Three-way Train-pipe Cocks 1½ x 1 in. (2). |
| 611. Car Ell, 1½ in. (6). | 642. Plug, 1 in. (6). | 740. Sockets for Three-way Train-pipe Cocks (2). |
| 612. Tee, 1½ x ¾ x 1½ in. (6). | 677. Covering for 1½ in. Pipe (120 ft.). | 742. Directions (framed) (1). |
| 616. Ells, 1 in. (8). | 680. Covering for 1 in. Pipe (90 ft.). | 755. Covering for 1½ in. Tee (6). |
| 616a. Ells, R. and L., 1 in. (6). | 681. Covering for 1 in. Ells (14 ft.). | 756. Covering for 1½ in. Ell (3). |
| 618. Couplings, 1½ in. R. and L. (4). | 682. Covering for 1 in. Tee (2 ft.). | 759. Floor-plate for Four-way Cock (1). |
| 621. Tee, 1 in. (2). | 699. Street Ells, 1 in. (2). | 763. Reduction Fitting (1). |
| 622. Extra Heavy Cocks, ¾ in. (6). | 734. Three-way Drain-cock, 1 in. (1). | 771. Covering 624b (3). |
| 624b. Double Jacket (3). | 735. Floor-plate for Three-way Drain-cock (1). | |
| 625. Standard Pipe, 1 in. (100 ft.). | 736. Socket for Three-way Drain-cock (1). | |
| 626. Extra Strong Pipe, 1½ in. (20 ft.). | | |

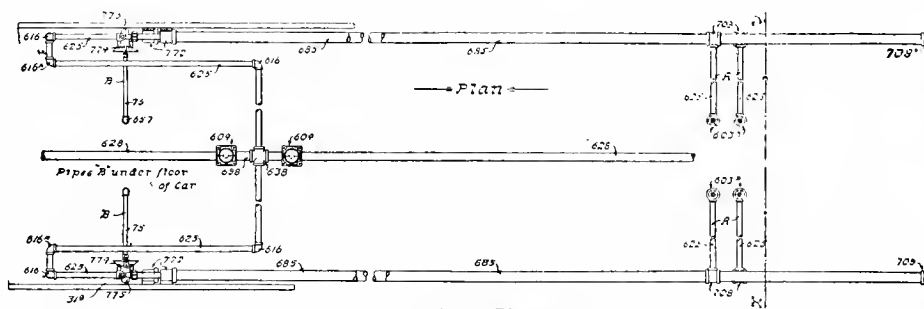

Fig. 3031. Plan.

Notes - Drain Pipes A & B must lead toward center of car where possible
radiators Pipes must drain to 70708

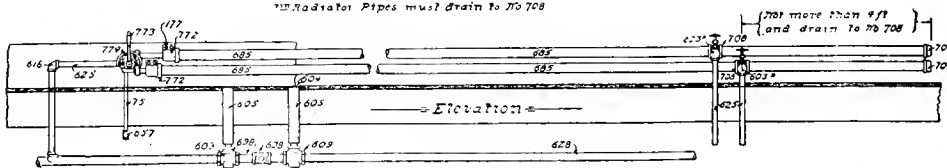

Fig. 3032. Elevation.

DIRECT STEAM REGULATING SYSTEM (L-188).

NAMES OF PARTS, CONSTITUTING ONE EQUIPMENT. Figs. 3031-3034.

- | | | |
|--|--|--|
| 31a. Plugs, ½ in. (2). | 616. Ells, 1 in. (6). | 679. Covering for 1½ in. Tees (2). |
| 75. Standard Pipe, ½ in. (10 ft.). | 616a. Ells R. and L., 1 in. (2). | 680. Covering for 1 in. Pipe (24 ft.). |
| 177. Lags, 2½ x ½ in. (8). | 618. Couplings R. and L., 1½ in. (2). | 681. Covering for 1 in. Ells (6). |
| 179. Lags, 2 x ¾ in. (16). | 625. Standard Pipe, 1 in. (30 ft.). | 683. Covering for 1½ in. Cross (1). |
| 180. Lags, 3½ x ¾ in. (8). | 628. Standard Pipe, 1½ in. (60 ft.). | 685. Standard Pipe, 2 in. (200 ft.). |
| 603b. Angle Drip-valves, 1 in. (2). | 631. Couplings R. and L., 1 in. (3). | 698. Nipples, 1½ x 3 in. (2). |
| 604. Floor-plates for Train-pipe Cocks (2). | 632. Straps and Backs for 2 in. Pipes (8). | 708. Eccentric Tees, 2 x 1 in. (4). |
| 605. Sockets for Train-pipe Cocks (2). | 638. Cross, 1½ x 1 in. (1). | 709. Caps, 2 in. (4). |
| 606. Wrench for Train-pipe Cocks (1). | 645. Directions (framed) (1). | 772. Special Reducers, 2 x ¾ in. (4). |
| 609. Asbestos-packed Train-pipe Cocks with Drip, 1½ in. (2). | 657. Ells, ½ in. (4). | 775. Three-way Cocks (with Arcs No. 774, and Levers No. 773), 1 in. (2). |
| | 677. Covering for 1½ in. Pipe (60 ft.). | |

Figs. 3033-3034. Cross Sections.

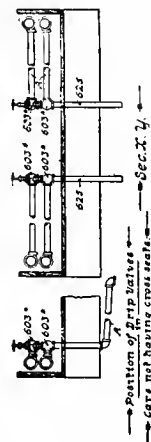

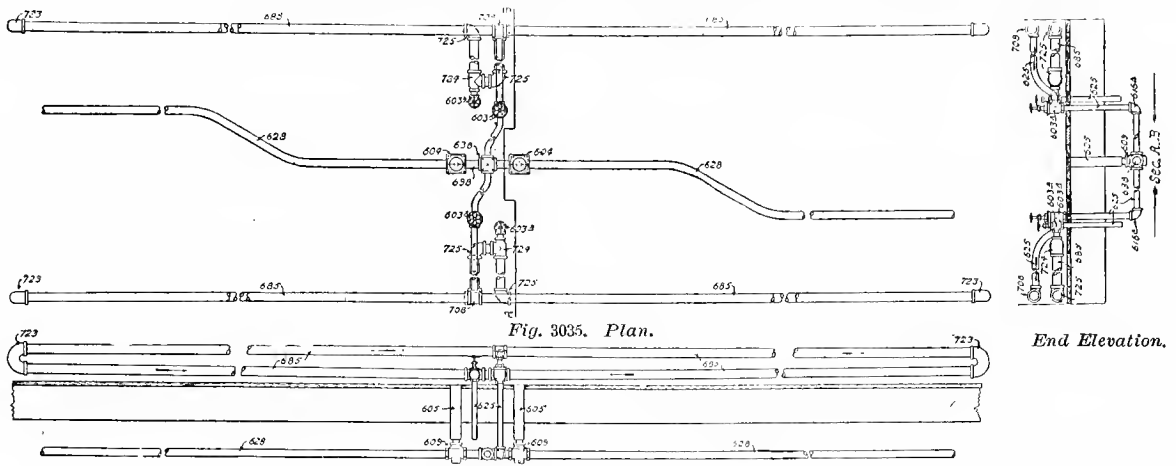

Fig. 3036. Elevation.
DIRECT STEAM SYSTEM (L-111).

NAMES OF PARTS CONSTITUTING ONE EQUIPMENT. Figs. 3035-3036.

- | | | |
|---|---|--|
| 179. Lag Screws, 2 in. x $\frac{3}{8}$ in. (24). | 609. Asbestos-packed Train-pipe Cocks with Drips, 1½ in. (2). | 683. Covering for 1½ in. Cross (1). |
| 603a. Angle Inlet-valves (regulating), 1 in. (2). | 616a. Ells, 1 in. R. & L. (2). | 685. Standard Pipe, 2 in. (200 ft.). |
| 603b. Angle Drip-valves, 1 in. (2). | 618. Couplings, R. & L. 1½ in. (2). | 698. Nipples, 1½ in. x 3 in. long (2). |
| 604. Floor-plates for Train-pipe Cocks (2). | 625. Standard Pipe, 1 in. (15 ft.). | 708. Tees, Eccentric, 2 in. x 1 in. (2). |
| 605. Sockets for Train-pipe Cocks (2). | 628. Standard Pipe, 1½ in. (60 ft.). | 723. O. P. Return Bends, 2 in. (4). |
| 606. Wrench for Train-pipe Cocks (1). | 638. Cross, 1½ in. x 1 in. (1). | 724. Tees, 2 in. x 1 in. x 2 in. (2). |
| | 677. Covering for 1½ in. Pipe (60 ft.). | 725. Ells, 2 in. (6). |
| | 679. Covering for 1½ in. Tees (2). | 732. R. & L. Couplings, 2 in. (4). |
| | 680. Covering for 1 in. Pipe (9 ft.). | 741. Directions (framed) (1). |
| | 681. Covering for 1 in. Ells (2). | 749. Pipe Straps (24). |

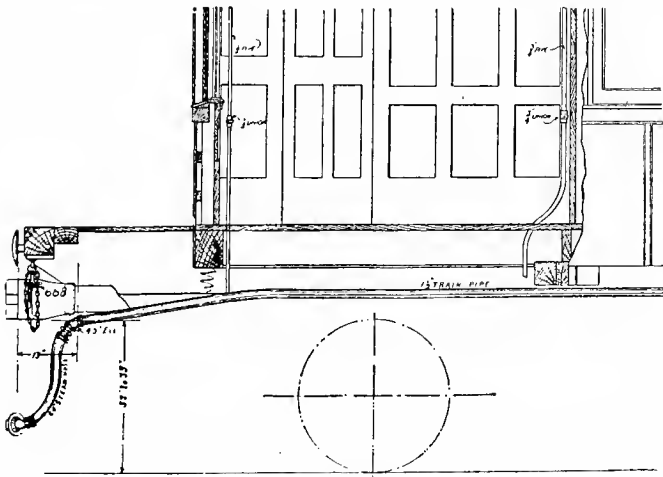

Fig. 3037.

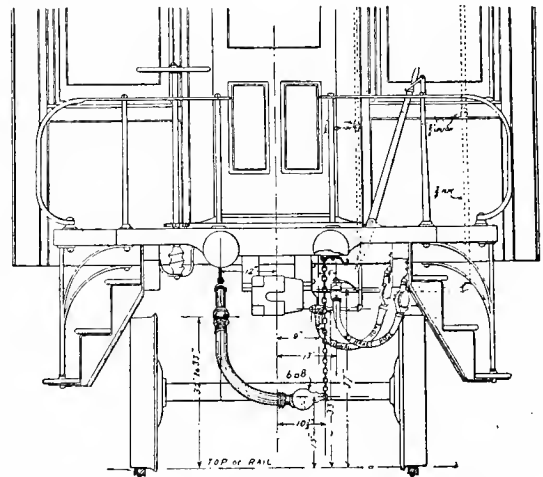
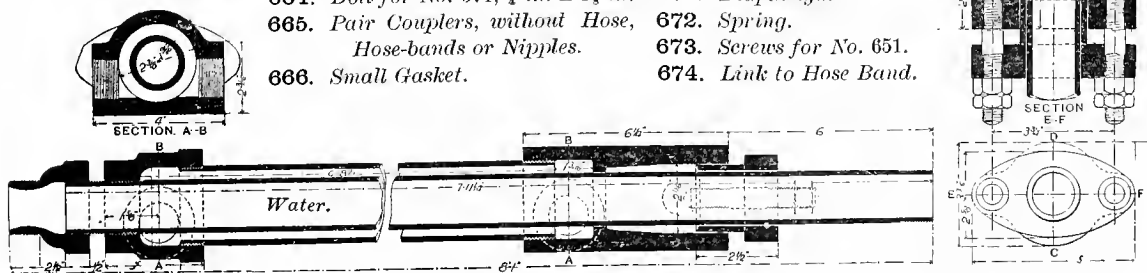

Fig. 3038.

STANDARD POSITIONS FOR GIBBS STEAM COUPLING AND WESTINGHOUSE BRAKE AND SIGNAL COUPLINGS.

NAMES OF PARTS. GIBBS STEAM COUPLER (NOT ILLUSTRATED).

- | | |
|--|----------------------------|
| 651. Large Ring above Diaphragm. | 667. Ring to Hold No. 666. |
| 654. Steam Hose, 24 in. long, 1½ in. | 68. Blank and Chain. |
| 655. Hose Nipple, 1½ in. Pipe. | 669. Large Gasket. |
| 656. Hose Band. | 670. Ell, 1½ in., 45°. |
| 664. Bolt for No. 674, ¼ in. x 1½ in. | 671. Diaphragm. |
| 665. Pair Couplers, without Hose, Hose-bands or Nipples. | 672. Spring. |
| 666. Small Gasket. | 673. Screws for No. 651. |
| | 674. Link to Hose Band. |



Figs. 3039-3042. Steam Jacket 624.

The Gland End of Jacket.

A steam jacket surrounds water pipe, and heats water of circulating system.

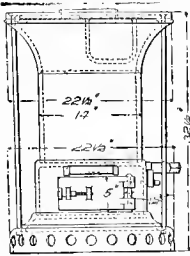

Fig. 3068a. Elevation.

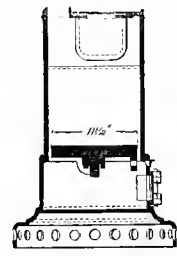

Fig. 3068c. Section.

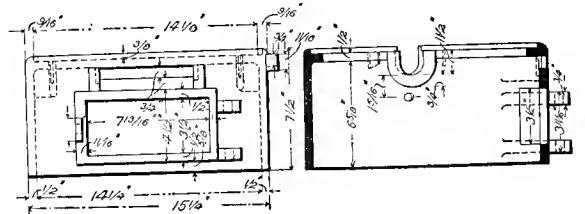

Fig. 3070. Ash-pit.

Fig. 3070a. Section of Ash-pit.

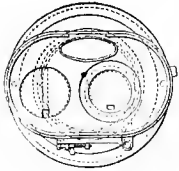

Fig. 3068b. Plan.

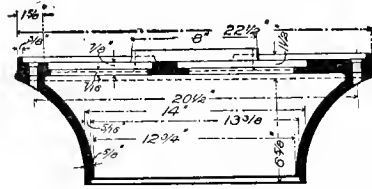

Fig. 3069. Top of Stove.

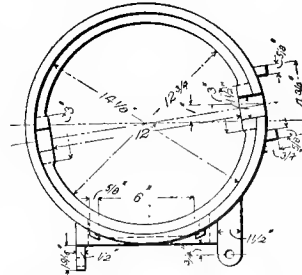

Fig. 3071. Plan of Ash-pit.

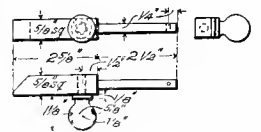
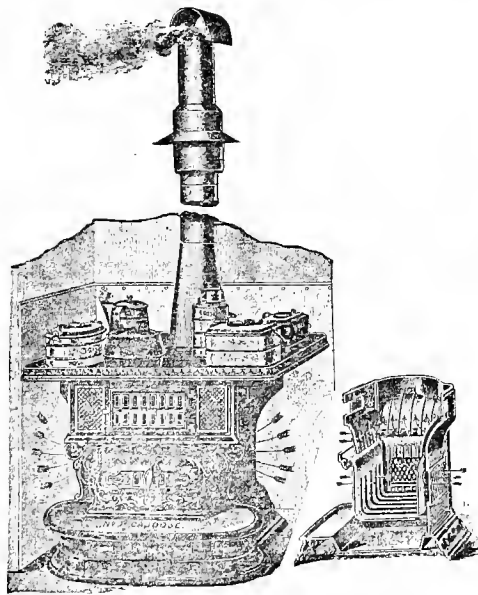
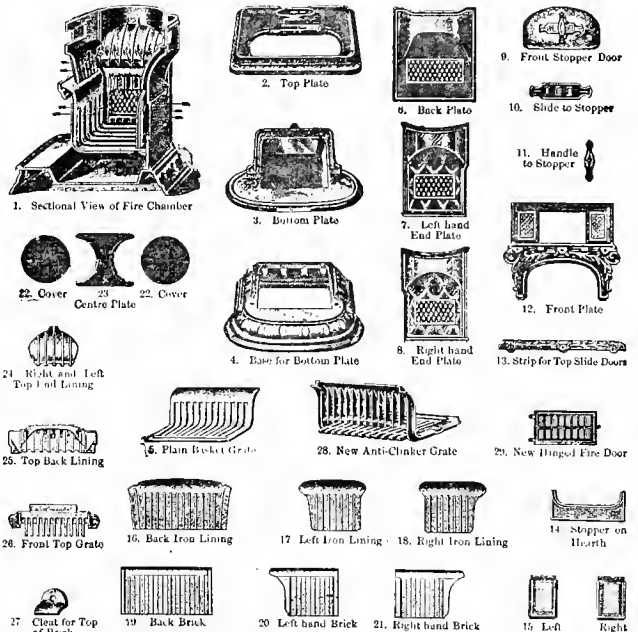

Fig. 3072ab. Door-latch.

CABOOSE STOVE AND PARTS. NEW YORK, LAKE ERIE & WESTERN RAILROAD.



Figs. 3073-3074. THE SPEAR CABOOSE STOVE.



Figs. 3075-3105. NAMES AND NUMBERS OF PARTS OF THE SPEAR CABOOSE STOVE.

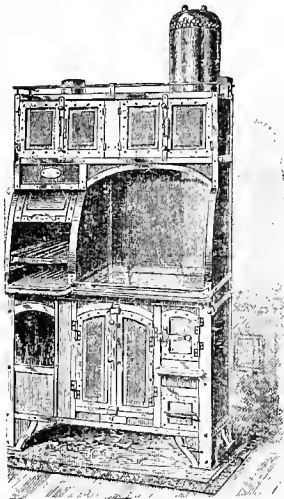

Fig. 3106. HOTEL-CAR RANGE, with broiler and hot-water tank. Size, 3 ft. 4 in. x 2 ft. 1 in. x 5 ft. 6 in. Weight, 725 lbs.

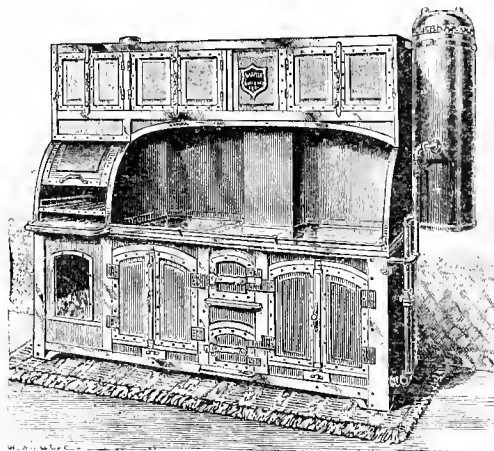

Fig. 3107. DINING-CAR RANGE, with broiler, hot-water tank and fuel closet. Size, 6 ft. 0 in. x 2 ft. 10 in. x 5 ft. 6 in. Weight, 1,250 lbs.

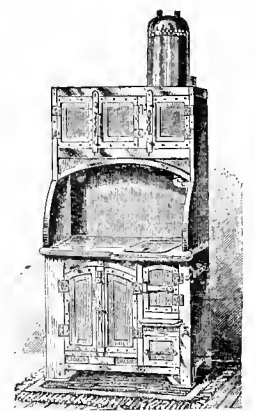

Fig. 3108. DIRECTORS'-CAR RANGE, with hot-water tank. Size, 2 ft. 6 in. x 1 ft. 10 in. x 5 ft. 0 in. Weight, 490 lbs.

NAMES OF PARTS OF REGULATOR. Figs. 3117-3118.

- | | |
|-----------------------|---------------------------|
| 1. Regulator-body. | 9. Reinforcing-plate. |
| 2. Top-plate. | 10. Diaphragm Flange-nut. |
| 3. Body-bolt. | 11. Valve. |
| 4. Adjusting-nut. | 12. Valve-seat. |
| 5. Lock-nut. | 13. Valve-seat Nut. |
| 6. Graduating-spring. | 14. Valve-chamber Cap. |
| 7. Diaphragm. | 15. Valve-cap Washer. |
| 8. Diaphragm-flange. | |

NAMES OF PARTS OF MERCURIAL CHECK VALVE.

Figs. 3119-3120.

- | | |
|-------------------|----------------------|
| 1. Valve-bowl. | 5. Set-screw. |
| 2. Valve-chamber. | 6. Set-screw Washer. |
| 3. Body-bolt. | 7. Body-washer. |
| 4. Air-pipe. | |

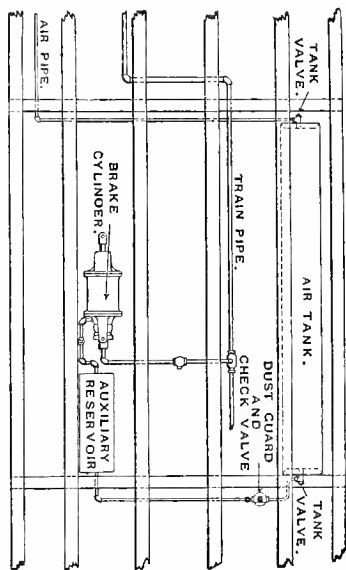

Fig. 310. Part Plan. GENERAL METHOD OF APPLICATION OF THE FROST DRY CARBURRETOR SYSTEM OF LIGHTING.

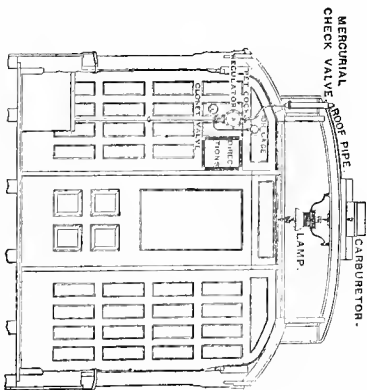

Fig. 311. Sectional End Elevation.

NAMES OF PARTS OF MERCURIAL SAFETY VALVE. Fig. 3124.

- | | |
|----------------------|----------------------|
| 1. Pressure-chamber. | 6. Relief-pipe. |
| 2. Relief-chamber. | 7. Return-bend. |
| 3. Cap. | 8. Set-screw. |
| 4. Cap-washer. | 9. Set-screw Washer. |
| 5. Pressure-pipe. | (Not shown.) |
| | 10. Deflector. |

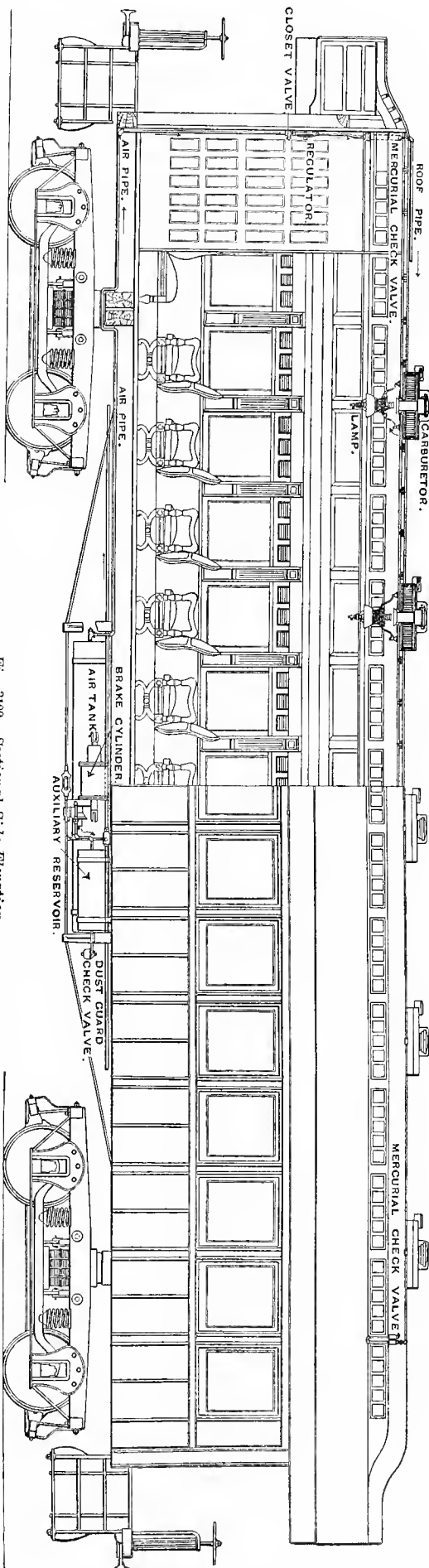
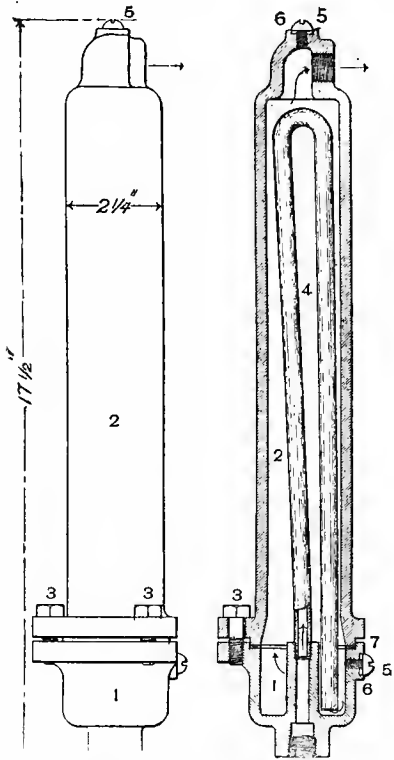
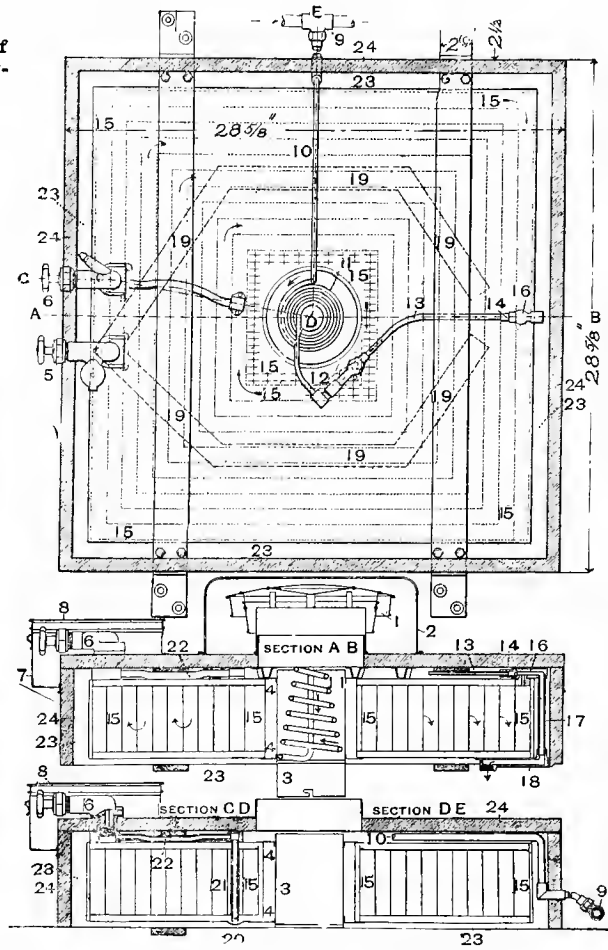

Fig. 3109. Sectional Side Elevation.

Numbers refer to Lists of Names of Parts on the Preceding and Following Pages.



Figs. 3119-3120. Elevation and Section. MERCURIAL CHECK-VALVE.



Figs. 3121-3123. Plan and Sections. FROST DRY CARBURETOR.

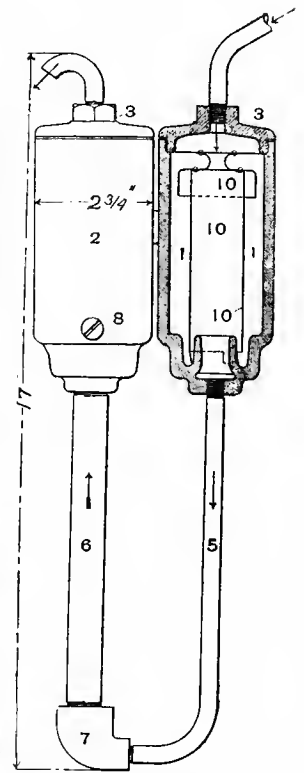

Fig. 3124. Sectional Elevation. MERCURIAL SAFETY-VALVE.

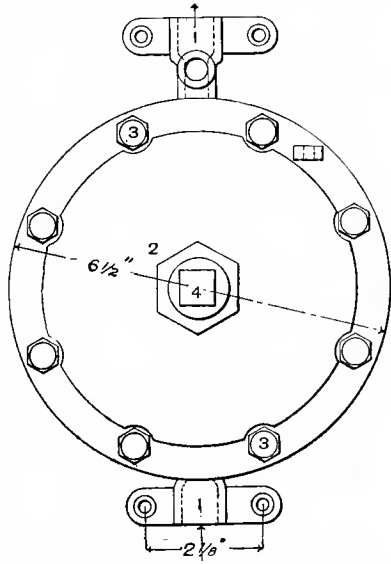

Fig. 3117. Elevation. REGULATOR.

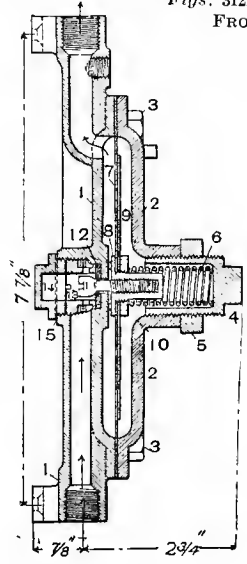

Fig. 3118. Cross Section.

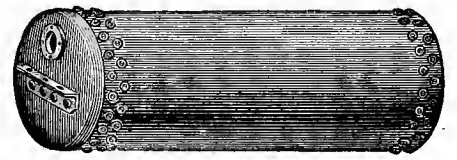
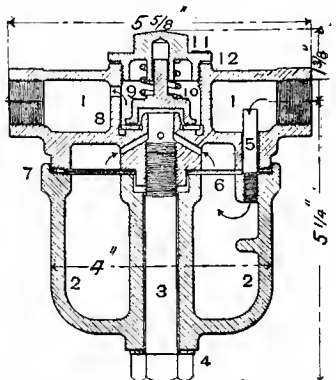
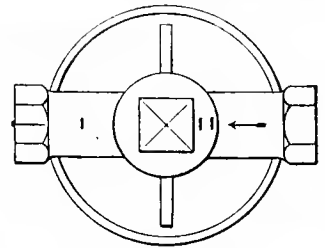

Fig. 3114. General View. TANK.



Figs. 3112-3113. Plan and Section. DUST-GUARD AND CHECK-VALVE. (254)

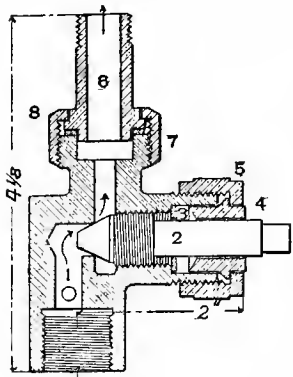

Fig. 3116. Section. CLOSET-VALVE.

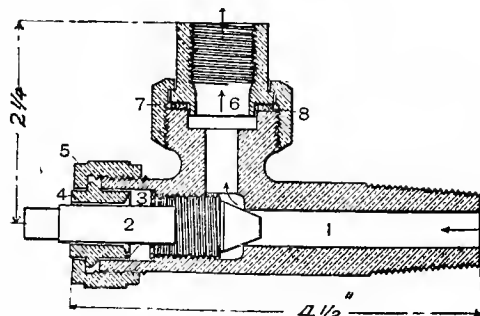

Fig. 3115. Section. TANK-VALVE.

THE FROST DRY CARBURETOR SYSTEM OF CAR LIGHTING.

NAMES OF PARTS OF FILLING VALVE.

Figs. 3125-3126.

1. Valve-body.
 2. Valve-needle.
 3. Packing-washer.
 4. Packing-gland.
 5. Packing-nut.
 6. Hand-wheel.
 7. Lead Washer.
 8. Cap.
 9. Leather Washer.
- (Not shown.)

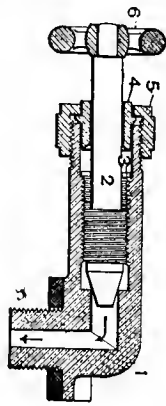

Figs. 3125-3126.
CARBURETOR FILLING-VALVE.

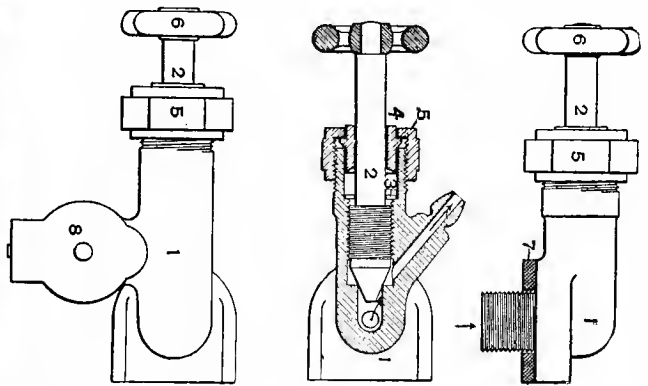

Figs. 3127-3128.
CARBURETOR BLEED-VALVE.

NAMES OF PARTS OF BLEED VALVE.

Figs. 3127-3128.

1. Valve-body.
2. Valve-needle.
3. Packing-washer.
4. Packing-gland.
5. Packing-nut.
6. Hand-wheel.
7. Lead washer.

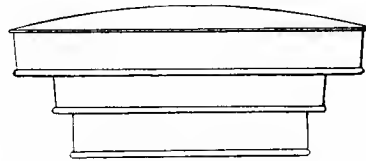

Fig. 3129. VENTILATOR.

NAMES OF PARTS OF CARBURETOR. Figs. 3121-3123.

1. Ventilator.
2. Cowl.
3. Carburetor-flue.
4. Carburetor-flue Flange.
5. Carburetor Filling-valve.
6. Carburetor Bleed-valve.
7. Carburetor Valve-box.
8. Carburetor Valve-box Cover.
9. Tee.
10. Air-pipe.
11. Copper-coil.
12. Air-inlet.
13. Air-tube.
14. By-pass Nipple.
15. Spiral-chamber.
16. Gas-oulet.
17. Gas-Nipple.
18. Gas-arm Ell.
19. Troughs.
20. Bleed-well.
21. Bleed-well Tube.
22. Bleed-well Nipple.
23. Hot-air Space.
24. Mantle, lined with Hair Felt.

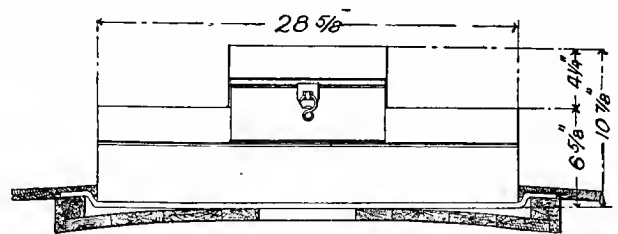

Fig. 3130. END VIEW OF CARBURETOR IN MANTLE.

NAMES OF PARTS OF DUST-GUARD AND CHECK-VALVE.

Figs. 3112-3113.

1. Valve-body.
2. Dust-cup.
3. Retaining-bolt.
4. Bolt-Washer.
5. Air Inlet-pipe.
6. Felt Dust-screen.
7. Body-washer.
8. Leather Valve-seat.
9. Valve-disc.
10. Valve-spring.
11. Valve-cap.
12. Valve-cap Washer.

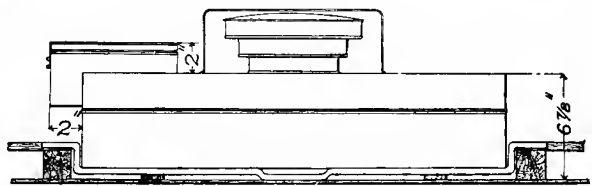

Fig. 3131. SIDE VIEW OF CARBURETOR IN MANTLE.

NAMES OF PARTS OF TANK VALVE. Fig. 3115.

1. Valve-body.
2. Valve-needle.
3. Packing-washer.
4. Packing-gland.
5. Packing-nut.
6. Socket— $\frac{1}{2}$ -in. pipe union.
7. Nut— $\frac{1}{2}$ -in. pipe union.
8. Gasket— $\frac{1}{2}$ -in. pipe union.

NAMES OF PARTS OF CLOSET VALVE. Fig. 3116.

1. Valve-body.
2. Valve-needle.
3. Packing-washer.
4. Packing-gland.
5. Packing-nut.
6. Nipple— $\frac{3}{8}$ -in. pipe union.
7. Nut— $\frac{3}{8}$ -in. pipe union.
8. Gasket— $\frac{3}{8}$ -in. pipe union.

NAMES OF PARTS. Fig. 3132.

1. Bracket-lamp Ceiling-plate.
2. Bracket-lamp Smoke-bell.
3. Bracket-lamp Smoke-flue.
4. Deck-lamp Ceiling-plate.
5. Deck-lamp Smoke-bell.

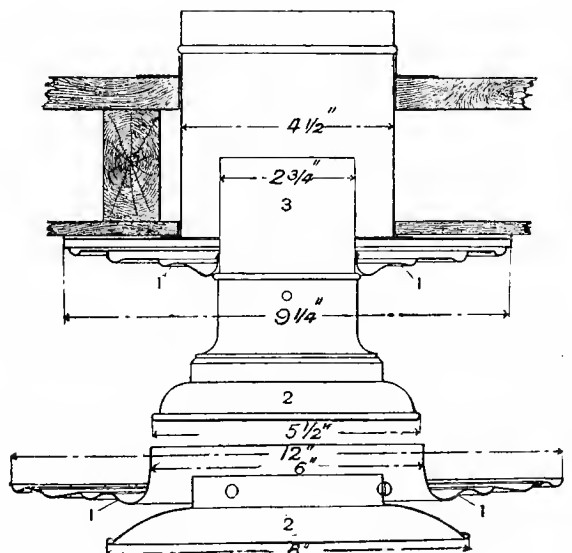

Fig. 3132. CEILING PLATES AND SMOKE-BELL.

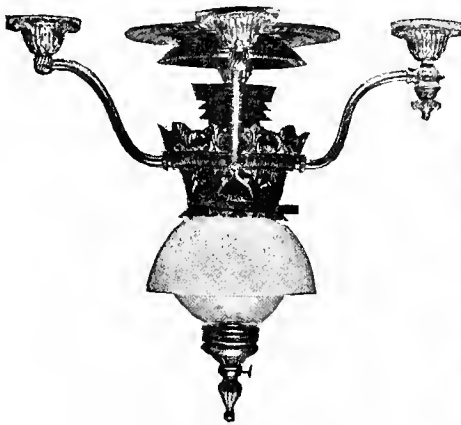

Fig. 3133. General View.
No. 3 FROST DECK-LAMP.

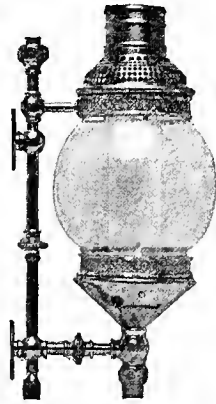

Fig. 3134. General View.
No. 2 FROST BRACKET-LAMP.

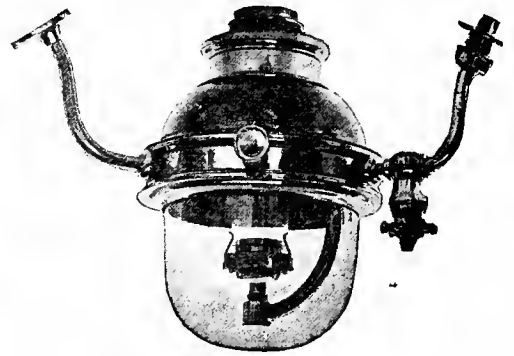

Fig. 3135. General View.
No. 1 FROST VESTIBULE-LAMP.

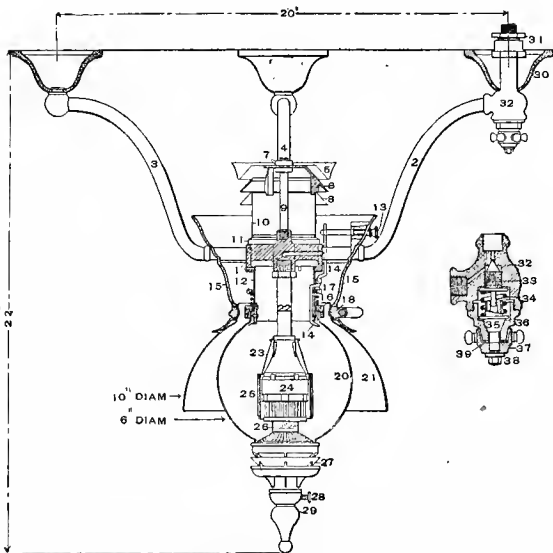

Fig. 3136.
No. 3 FROST DECK-LAMP.

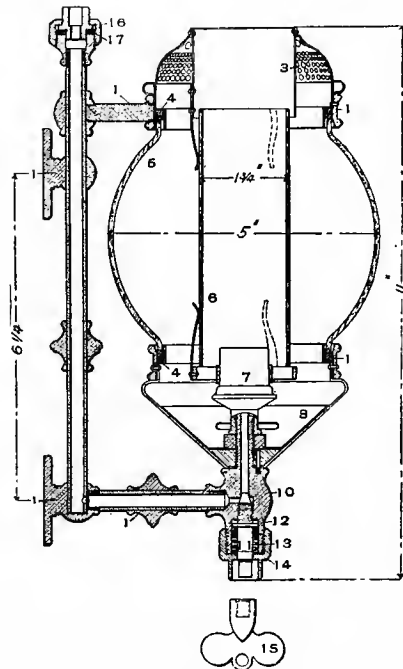

Fig. 3137.
No. 2 FROST BRACKET-LAMP.

NAMES OF PARTS OF NO. 3 DECK LAMP. Figs. 3133 and 3136.

- | | |
|--------------------------------|----------------------------|
| 1. Gas-body. | 21. Opal-shade. |
| 2. Gas-arm. | 22. Gas-nipple. |
| 3. Plain-arm, long. | 23. Air-deflector. |
| 4. Plain-arm, short. | 24. Burner. |
| 5. Wind-cap. | 25. Porcelain-cylinder. |
| 6. Ejector-spider. | 26. Air-controller. |
| 7. Retaining-nuts. | 27. Injector. |
| 8. Ejector-ring. | 28. Injector-latch. |
| 9. Binding-rod. | 29. Injector-latch Spring. |
| 10. Top-flue. | 30. Gas-arm Foot. |
| 11. Cone-top. | 31. Gas-arm Union. |
| 12. Bottom-flue. | 32. Valve-body. |
| 13. Globe Finger-knob. | 33. Valve-needle. |
| 14. Globe-finger. | 34. Valve-spring. |
| 15. Openwork-body. | 35. Valve-stem. |
| 16. Globe-collar. | 36. Valve-cap. |
| 17. Tube-spring. | 37. Valve-wheel. |
| 18. Shade-holder Clamp. | 38. Valve-wheel Nut. |
| 19. Shade-holder Clamp-spring. | 39. Valve-wheel Washer. |
| 20. Glass-globe or Bowl. | 40. Gas-arm-union Washer. |

NAMES OF PARTS OF NO. 2 BRACKET

LAMP. Figs. 3134 and 3137.

1. Lamp-bracket, with Lamp-body and Globe-supports, complete.
2. Globe-bracket Thumb-screw.
3. Top-cap and Ventilating-chimney.
4. Globe Packing-ring.
5. Glass Globe.
6. Glass Chimney.
7. Burner.
8. Shutter.
9. Shutter-knob. (Not shown.)
10. Valve bodg.
11. Valve-stem.
12. Valve-packing Washer.
13. Valve-packing Spring.
14. Valve-nut.
15. Valve-key.
16. 1/4-in. Union.
17. Washer.

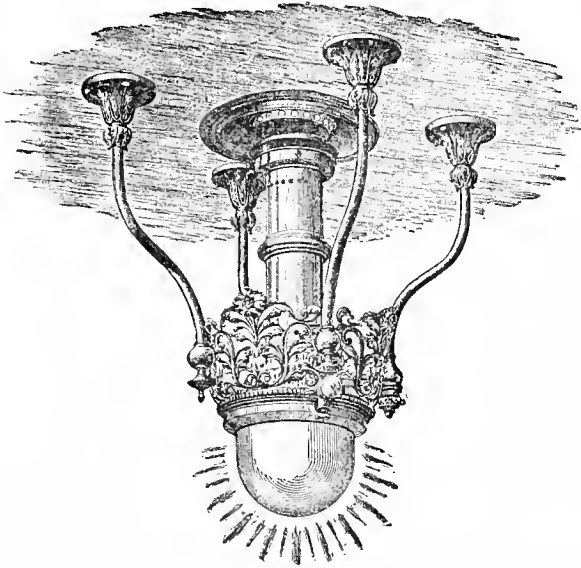

Fig. 3138. General View.

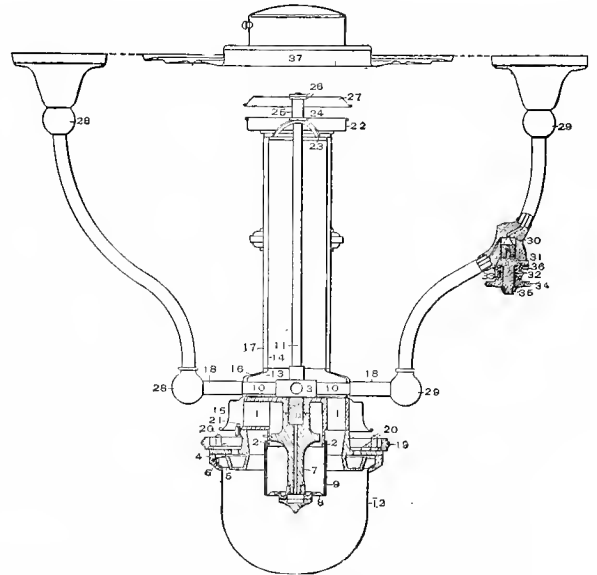

Fig. 3139. Section.

NO. 2 FROST DECK LAMP.

NAMES OF PARTS OF NO. 2 DECK LAMP. Figs. 3138-3139.

- | | | |
|------------------------------------|---|---|
| 1. Regenerator Casting. | 14. Steel Chimney. | 26. Deflector-cap Nuts. |
| 2. Top-plate or Deflector Casting. | 15. Cone-top. | 27. Deflector-cap. |
| 3. Brass Body. | 16. Cone-cap Casing. | 28. Lamp-arms. |
| 4. Globe-ring. | 17. Chimney-casing. | 29. Gas-arm with Needle-valve and Unions, Connections Complete. |
| 5. Globe Retaining-ring. | 18. Sleeves for Nipples. | 30. Needle. |
| 6. Globe Retaining-ring Screw. | 19. Beaded Ring. | 31. Valve-stem. |
| 7. Star Burner. | 20. Screws for Beaded Ring and Filigree Cresting. | 32. Spring. |
| 8. Perforated Flame-plate. | 21. Regenerator Retaining-screw. | 33. Cap. |
| 9. Porcelain Cylinder. | 22. Chimney-cap. | 34. Hand-wheel. |
| 10. Lamp-arm Nipples. | 23. Tripod. | 35. Nut. |
| 11. Center-rod for Chimney-flue. | 24. Tripod-nut. | 36. Cap-screw. |
| 12. Glass Globe No. 2. | 25. Spacing-sleeve. | 37. Ceiling-plate. |

NAMES OF PARTS OF NO. 1 VESTIBULE LAMP. Figs. 3135 and 3140.

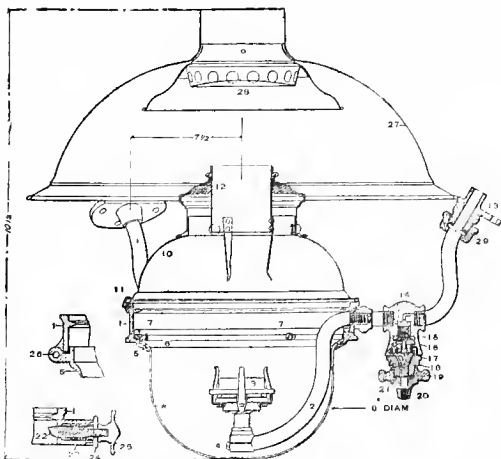

Fig. 3140. FROST VESTIBULE LAMP.

- | | |
|---------------------------------------|---------------------------|
| 1. Lamp Body with Arms. | 15. Valve-needle. |
| 2. Gas-arm. | 16. Valve-spring. |
| 3. Burner. | 17. Valve-stem. |
| 4. Burner Bleed-screw. | 18. Valve-cap. |
| 5. Globe-ring. | 19. Valve-wheel. |
| 6. Globe Retaining-ring. | 20. Valve-wheel Nut. |
| 7. Globe Retaining-ring Screw. | 21. Valve-wheel Washer. |
| 8. Glass Bowl. | 22. Latch. |
| 9. Glass Chimney. (Not shown.) | 23. Latch-spring. |
| 10. Top-shell and Reflector. | 24. Latch-cap. |
| 11. Top-shell Retaining-screw. | 25. Latch Finger-knob. |
| 12. Top-cap with Ventilating Chimney. | 26. Hinge-pin. |
| 13. Dome-flange. | 27. Dome. |
| 14. Valve-body. | 28. Smoke-bell. |
| | 29. Gas-arm Union-washer. |

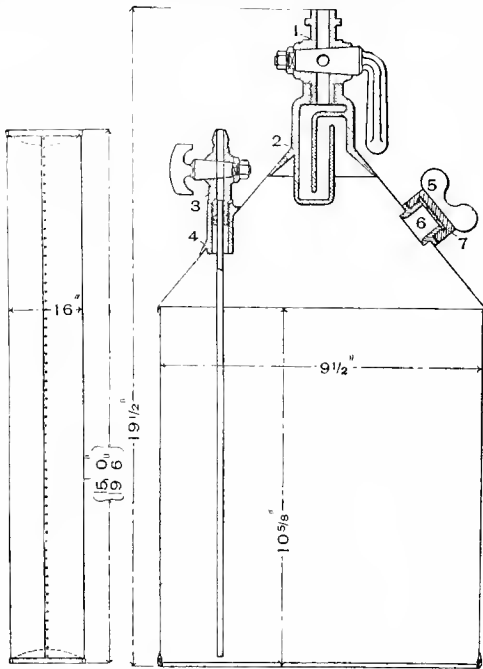

Fig. 3141.
AIR-TANK.

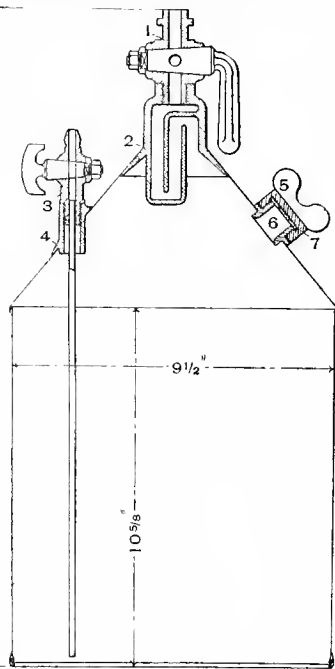

Fig. 3142. Sectional Side View.
FILLING CAN.

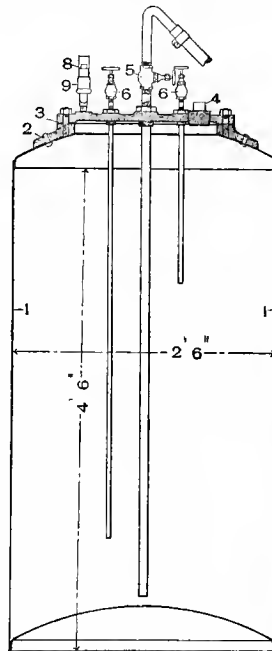

Fig. 3143. Sectional Front View.
STORAGE-TANK.

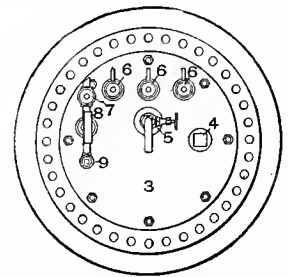

Fig. 3144. Top View.

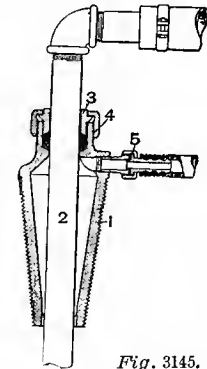

Fig. 3145.
Section of Transfer-plug.

Fig. 3150. OPERATING STICK.

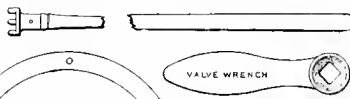

Fig. 3149.

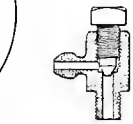

Fig. 3148.

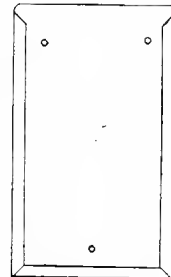

Fig. 3151.

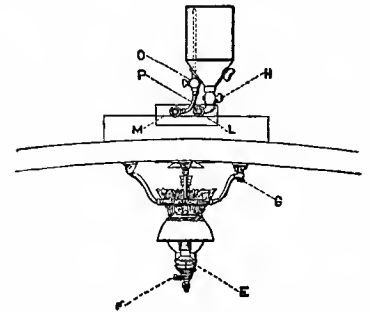

Fig. 3152.
SECTIONAL VIEW, SHOWING METHOD
OF FILLING CARBURETOR.

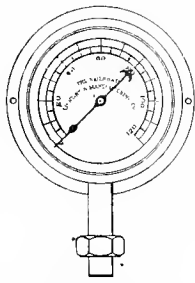

Fig. 3146.
AIR PRESSURE-GAGE.

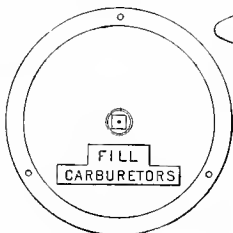

Fig. 3147.
INDICATOR DIAL.

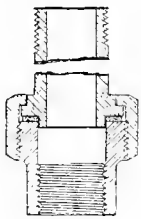

Fig. 3153.
NIPPLE-UNION.

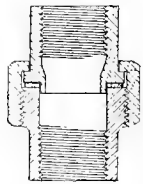

Fig. 3154.
SOCKET-UNION.

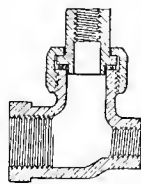

Fig. 3155.
CARBURETOR
UNION-TEE.

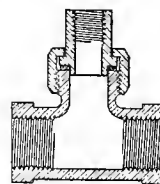

Fig. 3156.
CARBURETOR
UNION-TEE.

NAMES OF PARTS. Fig. 3142.

1. Filling-valve.
2. Filling valve Flange with Trap.
3. Bleed-valve.
4. Bleed-valve Flange.
5. Filling-plug.
6. Filling-plug Flange.
7. Filling-plug Washer.

NAMES OF PARTS. Fig. 3145.

1. Body.
2. Discharge-pipe.
3. Packing-gland.
4. Packing-nut.
5. 1/4-inch Union with Hose Nipple.

NAMES OF PARTS. Figs. 3143-3144.

1. Storage-tank.
2. Tank-flange.
3. Tank-core.
4. Filling-plug.
5. Discharge-valve.
6. Gage-cocks.
7. Check-valve.
8. Air-gage.
9. Safety-valve.

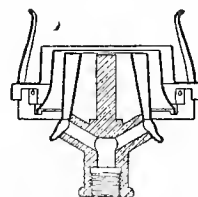

Fig. 3157. BURNER FOR
No. 1 VESTIBULE
LAMP.

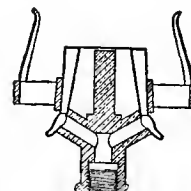

Fig. 3158. BURNER FOR
No. 2 BRACKET
LAMP.

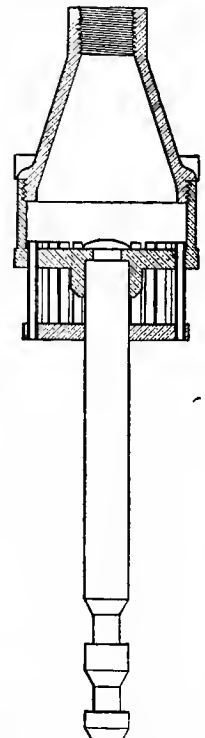

Fig. 3159. BURNER FOR
No. 3 DECK LAMP.
(258)

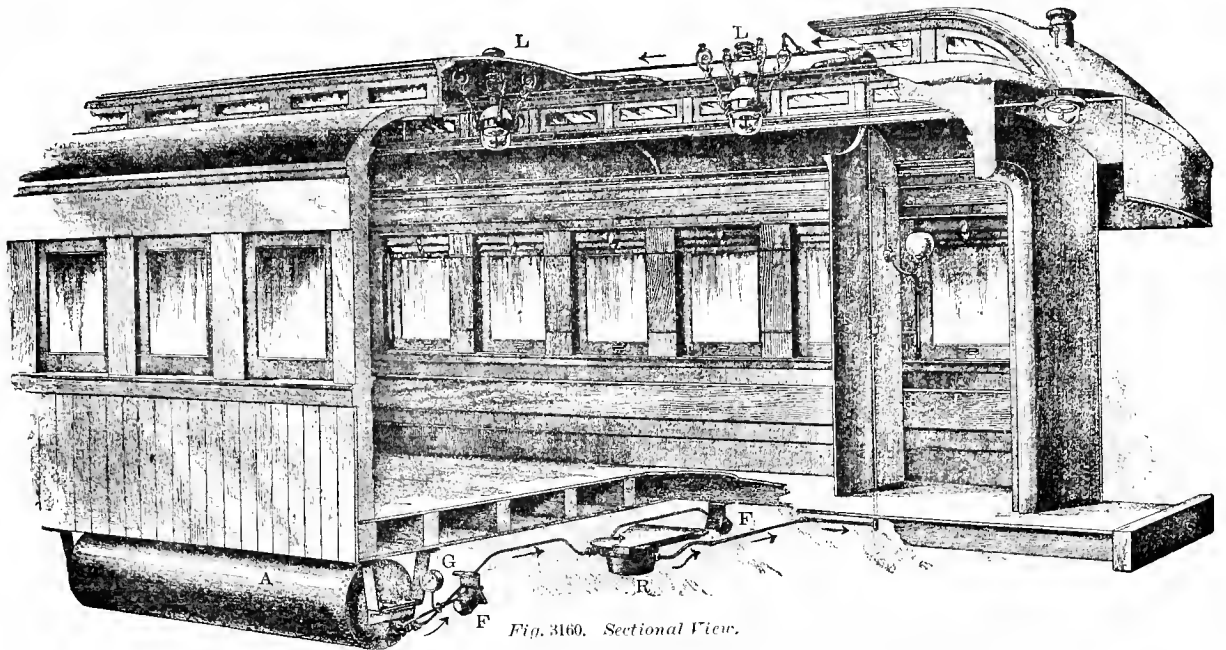

Fig. 3160. Sectional View.

GENERAL METHOD OF APPLICATION OF PINTSCH SYSTEM OF GAS LIGHTING TO PASSENGER-CARS.

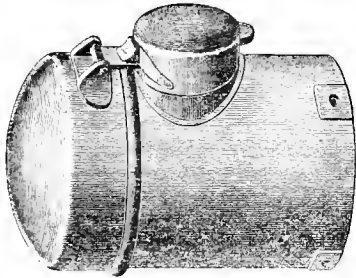

Fig. 3161.

No. 89. FILLING-VALVE COVER (F).

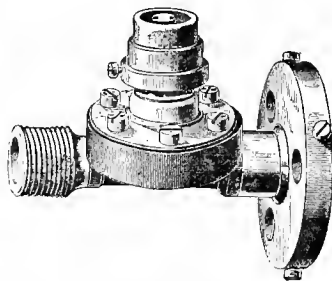

Fig. 3162.

No. 65. FILLING-VALVE FOR CARS.



Fig. 3163.

No. 118a. BRACKET FOR FILLING-VALVE.

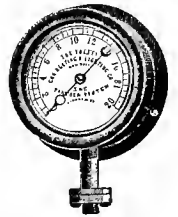

Fig. 3164.

No. 214. GAGE FOR CAR (G).



Fig. 3165.

No. 245-250. RECEIVER (A).

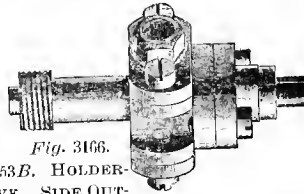

Fig. 3166.

No. 53B. HOLDER-VALVE, SIDE OUTLETS, $\frac{1}{4}$ in.



Fig. 3167.

No. 9. CONNECTION-PIECE, $\frac{1}{4}$ in.



Fig. 3168.

No. 244. REGULATOR (R).

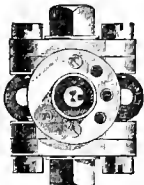

Fig. 3169.

No. 25, 25B, 25C. MAIN COCK, $\frac{1}{4}$, $\frac{3}{8}$ and $\frac{1}{2}$ in.

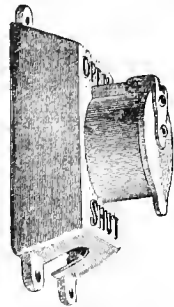

Fig. 3170.

No. 135, 135C. COVER FOR MAIN COCKS.

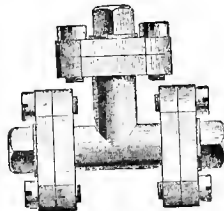

Fig. 3171.

Nos. 54-55. FLANGED TEES, $\frac{1}{4}$ -in. SIDE OUTLETS, $\frac{3}{8}$ -in. and $\frac{1}{2}$ -in.

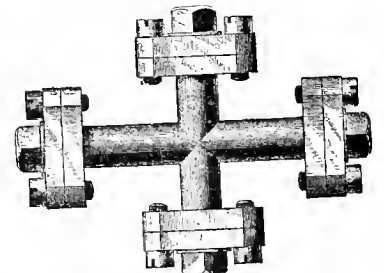

Fig. 3172.

No. 55a. FLANGED CROSS, $\frac{1}{4}$ -in.

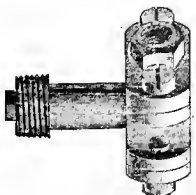

Fig. 3173.

No. 49. FLANGE TEE FOR REGULATOR, $\frac{1}{4}$ -in. (259)

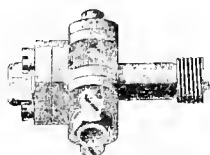

Fig. 3174.

No. 53A. FLANGE TEE FOR REGULATOR, $\frac{1}{4}$ -in.



Fig. 3175.

Nos. 12-13. TEE FLANGE UNIONS, $\frac{1}{4} \times \frac{3}{8}$ -in.; $\frac{1}{4} \times \frac{1}{2}$ -in.

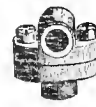

Fig. 3176.

No. 17A. ANGLE FLANGE, $\frac{1}{8}$ -in.



Fig. 3177.

No. 16A, B and C. TEE FLANGES, $\frac{3}{4} \times \frac{1}{8}$ -in.; $\frac{3}{4} \times \frac{3}{8}$ -in.; $\frac{3}{4} \times \frac{1}{2}$ -in. Nos. 49, 53B, 53A and 120.



Fig. 3178.

No. 3. FLANGE FOR Nos. 49, 53B, 53A and 120.



No. 167. Bracket. Nos. 27-56. Locknuts. No. 8A. Flange. No. 21. Burner Cock. Nos. 4-5. Connec- tion. No. 32A. Elbow. Nos. 130-134. Coup- lings. No. 170. Bolt for Tank- strap. 2½×⅝-in. No. 171. Bolt for Filling Valve. 1¾×½-in. Nos. 29-57. Cap. ½-in. Nos. 28-28A. Reducing Elbows. ¾×¼-in. ½×½-in.

Figs. 3179-3190. BOLTS AND FITTINGS.



No. 26. Nipple to Support Lamp, ⅜-in. (Give thickness of roof.)

No. 188. Screws. No. 185. Check Screw. No. 112. Plug. No. 31A. Check Screw. No. 141. Check Screw. No. 150. Flange Screw. Nos 175-176. Long Lag Screw for Tank-strap. 7×⅝-in. 5×⅝-in.

Figs. 3191-3193. SCREWS, BOLTS, AND FITTINGS.

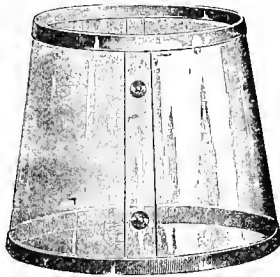

Fig. 3139. No. 109. MICA CHIMNEY.

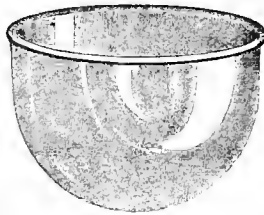

Fig. 3200. No. 100. GLASS BOWL.

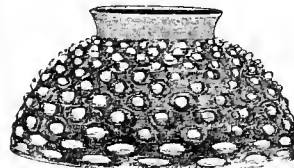

Fig. 3201. No. 101. OPALESCENT WART DOME. GLASS FOR NO. 205 LAMP.



Fig. 3202. No. 103.

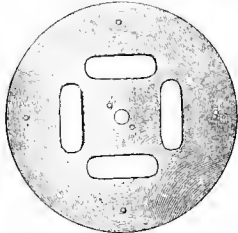

Fig. 3203. No. 112. FOUR-FLAME REFLECTOR.

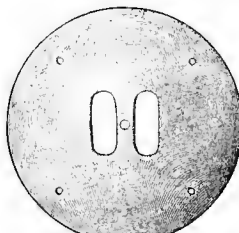

Fig. 3204. No. 113. TWO-FLAME REFLECTOR.

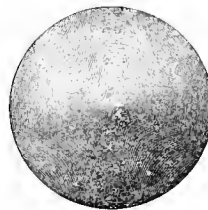
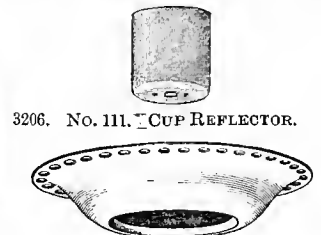

Fig. 3205. No. 114. REFLECTOR FOR WALL-LAMP.



3206. No. 111. CUP REFLECTOR.

Fig. 3207. No. 110. RING REFLECTOR.



Fig. 3208. No. 104. OPAL DOME.

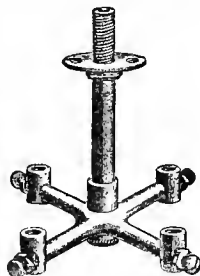

Fig. 3209. No. 227. FOUR-FLAME CLUSTER FOR CENTER LAMP.

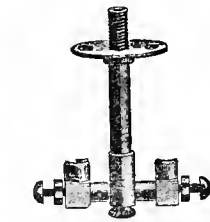
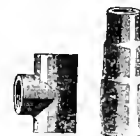

Fig. 3210. No. 226A. TWO-FLAME CLUSTER FOR VESTIBULE LAMPS.



No. 222. BURNER.



No. 34. TEE. No. 230. PINTSCH ½-in. PILLAR FOR BRACKET LAMP.



Fig. 3214. No. 45.



Fig. 3215. No. 46. KEYS FOR LAMPS AND VALVES.

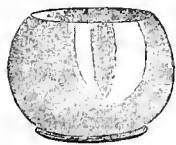

Fig. 3216. No. 102. 4-IN. OPAL GLOBE.

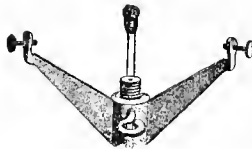

Fig. 3217. No. 80B. HOLDER FOR GLOBE NO. 102.

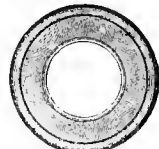

Fig. 3218. No. 60. LEAD WASHER FOR LARGE VALVE AND FLANGES.

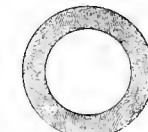

Fig. 3219. No. 61. RUBBER WASHER FOR NO. 60.



Fig. 3220. No. 62. LEAD WASHER FOR SMALL VALVES AND FLANGES.



Fig. 3221. No. 63. RUBBER WASHER FOR NO. 62.



Fig. 3222. Nos. 203-204. VENTILATORS. 6½-in.; 4⅝-in.



Fig. 3223. No. 231. MILL CHECK.



Fig. 3224. No. 23. IRON WASHER.

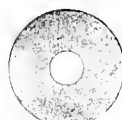

Fig. 3225. No. 24. RUBBER WASHER FOR NO. 23.



Fig. 3226. No. 6. IRON RING.

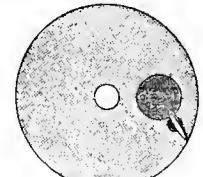

Fig. 3227. No. 200. WIND GUARD.



Figs. 3227 a b. No. 243. REGULATOR STRAP.



No. 161. PIPE STRAP.

NAMES OF PARTS OF VESTIBULE LAMP.

- Fig. 3339.
 100. Glass-bowl.
 113. Reflector.
 142. Check-screws for Cluster.
 155. Screws to fasten Hinge.
 156. Screws for Cluster-stem.
 157. Screws for Reflector Ventilator.
 204. Burner-tips.
 222. Cluster.
 226a. Cluster-stem.
 305. Cluster-stem Lock-nut.
 307. Bezel, or Ring for Bowl, with Hinge.
 308. Clips for Bowl.



Fig. 3228. No. 85. SWING-BRACKET WITH LOCK.

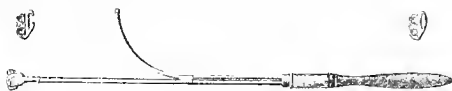

Fig. 3229. No. 300. TORCH AND KEY.



Fig. 3230. No. 120. FITTING FOR HOLDERS.



Fig. 3231. No. 80A. HOLDER FOR SHADE No. 80.



Fig. 3232. No. 80. POSTAL CAR SHADE.



Fig. 3233. No. 135B. COVER FOR MAIN COCKS FOR Nos. 25, 25B, 25C.

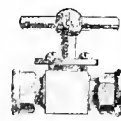

Fig. 3234. No. 22. MAIN COCK FOR POSTAL CARS.



Fig. 3235. No. 192. CENTER-SUSPENSION GAS-LAMP. (Wagner Pattern.)

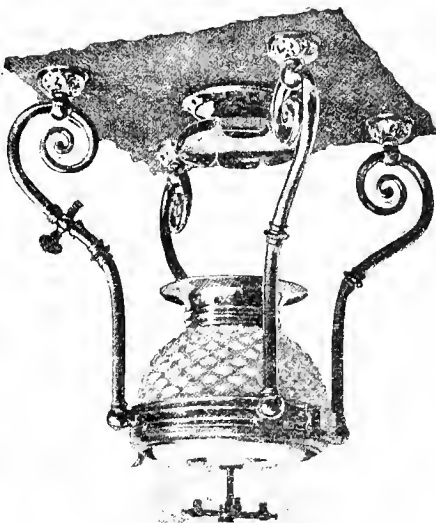

Fig. 3236. No. 196. FOUR-ARM LAMP.



Fig. 3237. No. 193. CENTER-SUSPENSION GAS-LAMP. (Fullman Pattern.)

NAMES OF PARTS OF VESTIBULE LAMP. Fig. 3339. (Concluded.)

316. Spring-catch (complete).
 318. Plug for Cluster.
 319. Locknut for Check-screws.
 320. Body-casting.
 321. Flues.
 322. Top-piece for Flues.
 323. Diaphragm.
 324. Ventilating-chimney.
 325. Center-post for Flues.
 326. Cock (complete).
 327. Gas-way.
 345. Spun Globe-holder Ring.

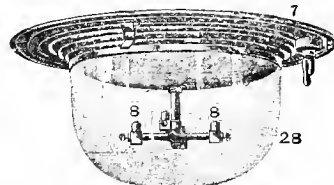

Fig. 3241. FOUR-FLAME VESTIBULE LAMP No. 195. Two-flame Vestibule Lamp No. 194 is shown in Fig. 3239.

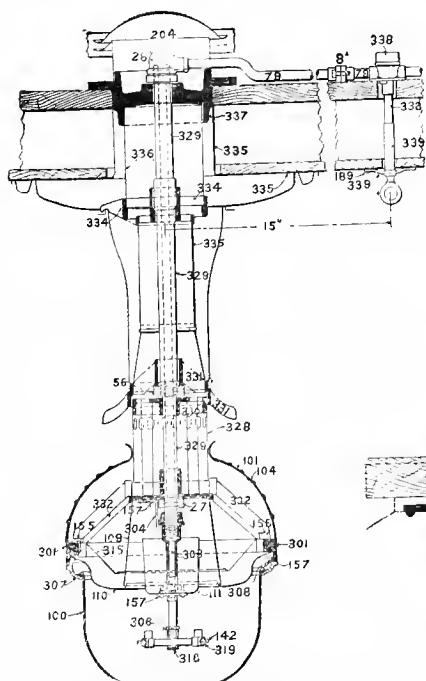

Fig. 3238. Nos. 192 and 193. SECTION CENTER-SUSPENSION LAMP. (261)

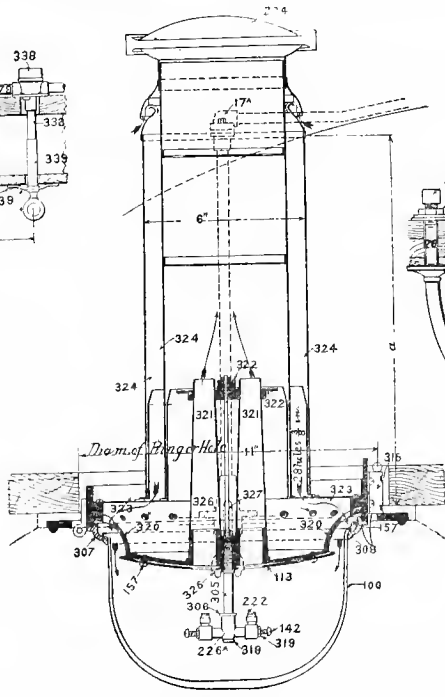

Fig. 3239. SECTION VESTIBULE LAMP.

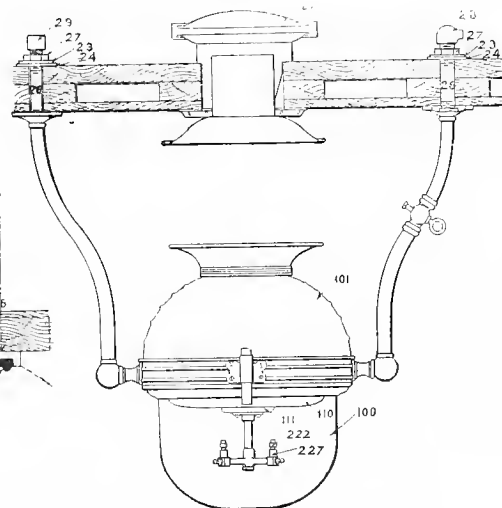

Fig. 3240. METHOD OF HANGING FOUR-ARM LAMPS.

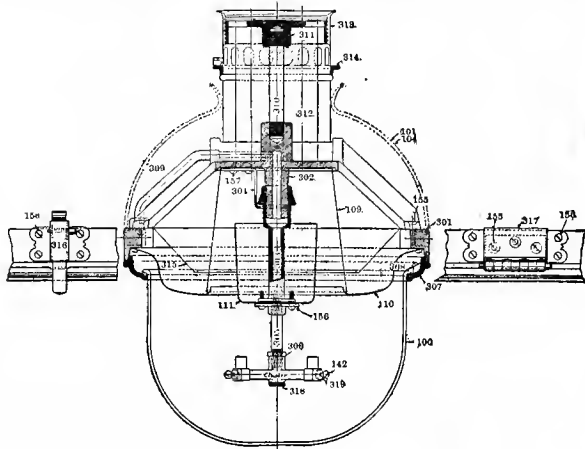

Fig. 3242.
STANDARD LAMP-BODY.

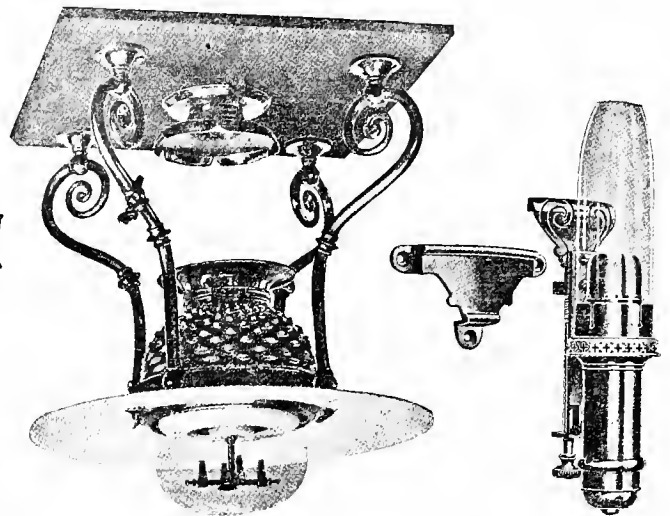

Fig. 3243.
FOUR-ARM GAS-LAMP WITH MAIL-CAR
REFLECTOR, No. 115.

Figs. 3244-3245.
No. 233. No. 232.
WALL- CANDLE
PLATE. BRACKET LAMP.

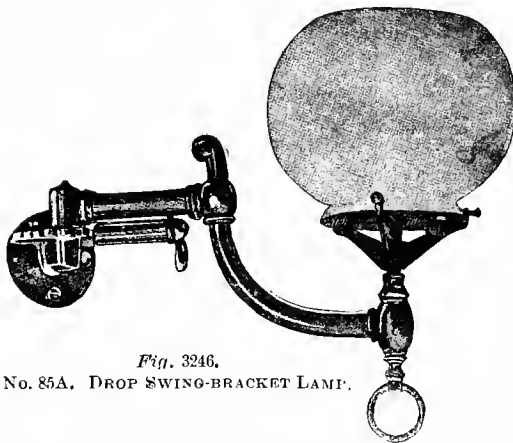

Fig. 3246.
No. 85A. DROP SWING-BRACKET LAMP.

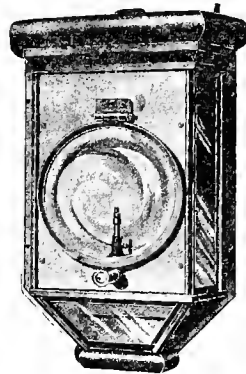
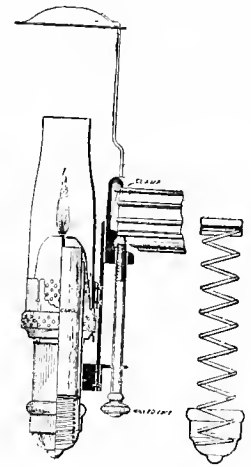

Fig. 3247.
No. 205. SALOON OR EXPRESS
WALL LAMP.



Figs. 3248-3249.
BRACKET EMERGENCY CANDLE
LAMP, PULLMAN'S PATERN.

NAMES OF PARTS OF CENTER-SUSPENSION LAMPS.

Fig. 3238.

- 8a. Flange Union.
- 28A. Ell. $\frac{1}{2} \times \frac{1}{8}$ in.
- 56. Locknut, $\frac{1}{2}$ in.
- 189. Screws for No. 339.
- 328. Chimney.
- 329. Gas-way.
- 330. Top-ring for Flues.
- 331. Lower Frame-casting.
- 332. Spider.
- 333. Flue.
- 334. Upper Frame-casting.
- 335. Thimble and Flange.
- 336. Top-flue.
- 337. Roof-casting.
- 338. Cock.
- 339. Thumb-piece, Socket and Plate.
- 345. Spun Globe-holder Ring.

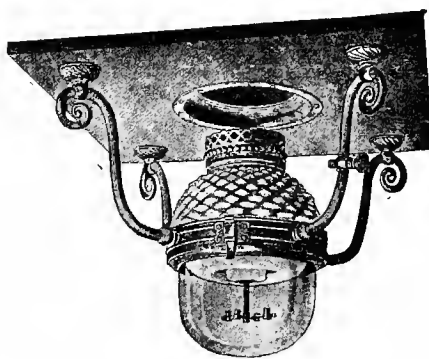

Fig. 3250.
No. 217. STREET-CAR LAMP.

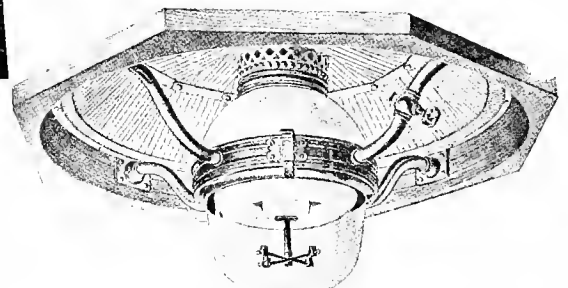

Fig. 3251.
No. 216. STREET-CAR LAMP.

NAMES OF PARTS OF CENTER-LAMPS.

Fig. 3242.

- | | | | |
|--|--|---|--------------------------------|
| 23. Special Iron Washer. | 111. Cup-reflector. | 229. Six-flame Cluster. | 312. Flues. |
| 24. Special Rubber Washer | 142. Check-screws for Cluster. | 301. Ring (cast iron). | 313. Chimney. |
| 26. Special $\frac{3}{8}$ -in. Pipe-nipple. | 155. Screws for Hinge. | 302. Spider. | 314. Ring for Fastening Crown. |
| 27. Locknut, $\frac{3}{8}$ in. | 156. Screws for Cluster-stem. | 303. Extension-pillar. | 315. Diaphragm. |
| 28. $\frac{3}{8}$ -in. \times $\frac{1}{2}$ -in. Reducing-elbow. | 157. Screws for Reflector. | 304. Lock. | 316. Spring-catch (complete). |
| 29. $\frac{3}{8}$ -in. Cap. | 204. Globe-ventilator. | 305. Cluster-stem. | 317. Hinge-cover. |
| 79. $\frac{1}{2}$ -in. X-pipe. | 222. No. 40 Burner. | 306. Locknut for Cluster-stem. | 318. Plug for Cluster. |
| 100. Glass-bowl. | 226. Two-flame Cluster for Center-lamp. | 307. Bezel, or Ring for Bowl, with Hinge. | 319. Locknut for Check-screws. |
| 101. Opalescent-dome. | 227. Four-flame Cluster for Center-lamp. | 308. Clips for Bowl. | |
| 104. Opal-dome. | 228. Five-flame Cluster. | 309. Gas-lube. | |
| 109. Mica Chimney. | | 310. Post. | |
| 110. Ring-reflector. | | 311. Top-piece for Flues. | |



Fig. 3252. Drop over-all, 26 ins.
Acme Burner.



Fig. 3253. Drop, 26 ins.
Dual Burner.

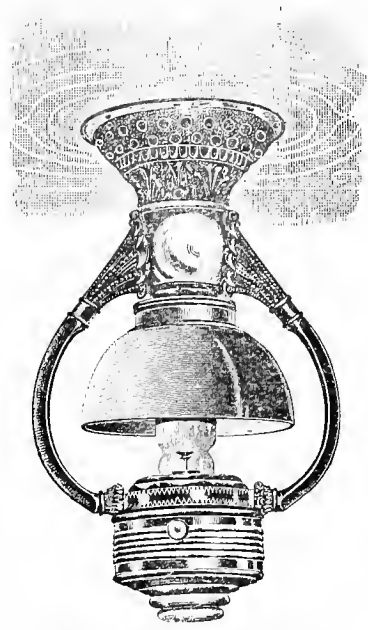

Fig. 3254. Drop over-all, 23 ins.
Acme Burner.

PILLAR-SUPPORTED OR SINGLE CENTER-LAMPS.



Fig. 3255.
Curtained Lamp for Compartment Cars.
Acme Burner. Drop over-all, 25½ ins.

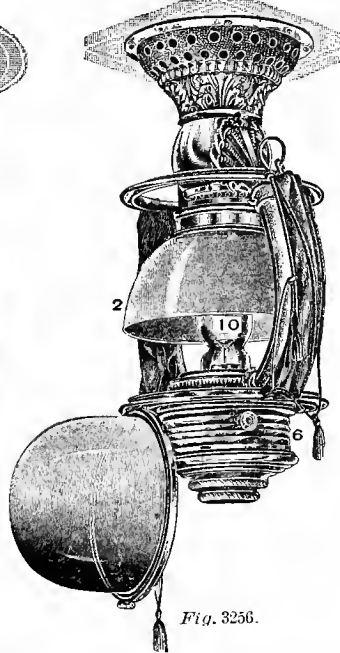

Fig. 3256.

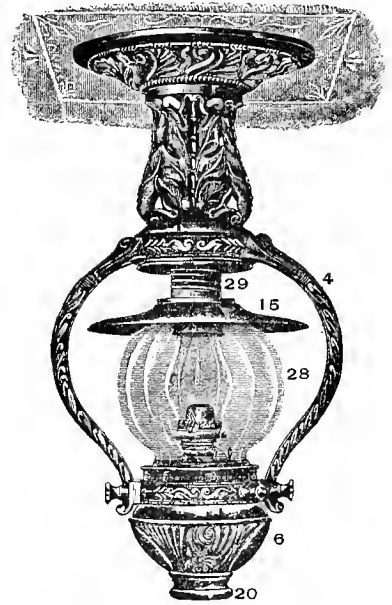

Fig. 3257.
Dual Burner. Drop, 26 ins.

SINGLE OR PILLAR-SUPPORTED CENTER-LAMPS.

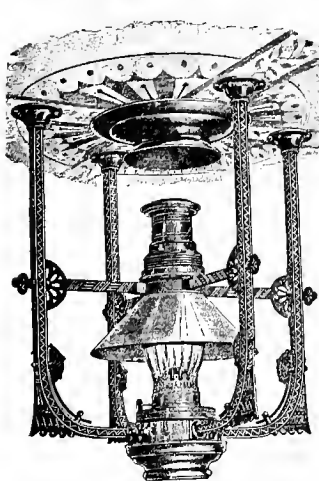

Fig. 3258. Tornado Lamp.
Drop over-all, 24 ins.
Tubular Construction.



Fig. 3259. Candle Lamp, and Candle
Socket detached. Drop, 25 ins.
FOUR-ARM SUPPORT CENTER-LAMPS.

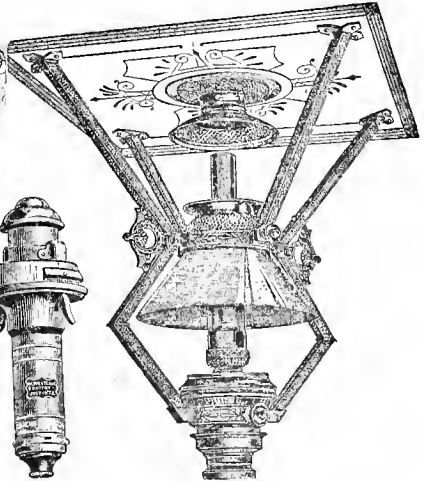

Fig. 3260.
Drop over-all, 24 ins.
Moehring's Center-draft Burner.

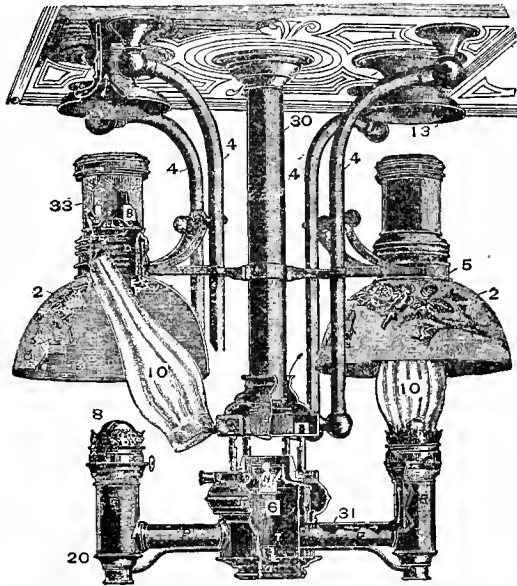

Fig. 3261. Sectional View of Improved Hurricane Chandelier, One Fount, Dual Burners.

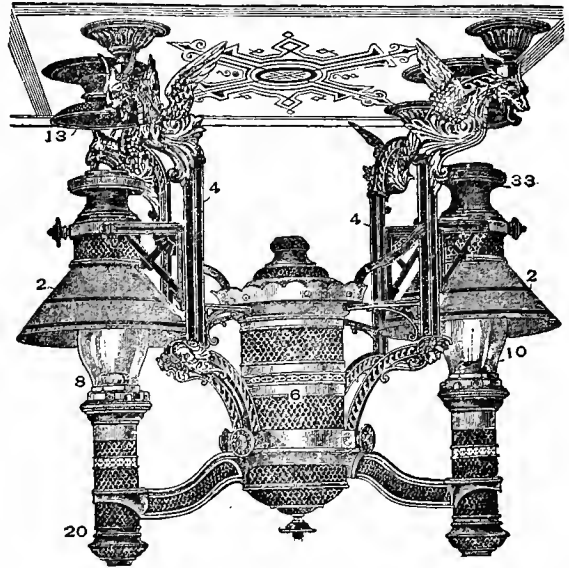

Fig. 3262 Hurricane Chandelier, Student-lamp Chandeliers. Principle, Dual Burners; Drop, 26 ins.

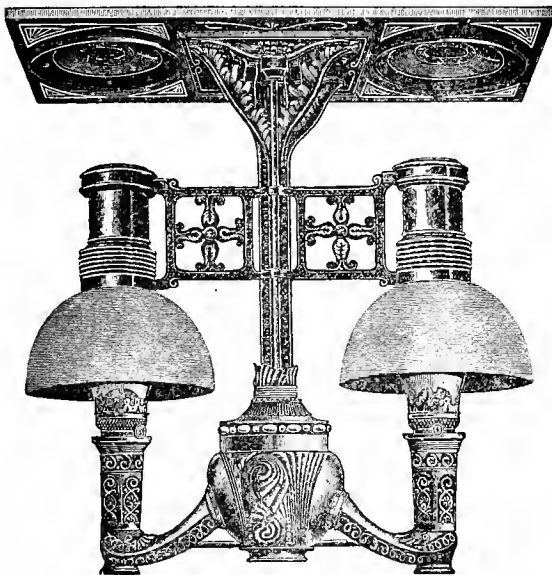

Fig. 3263. One-fount Dual Burner; Drop, 27 ins.

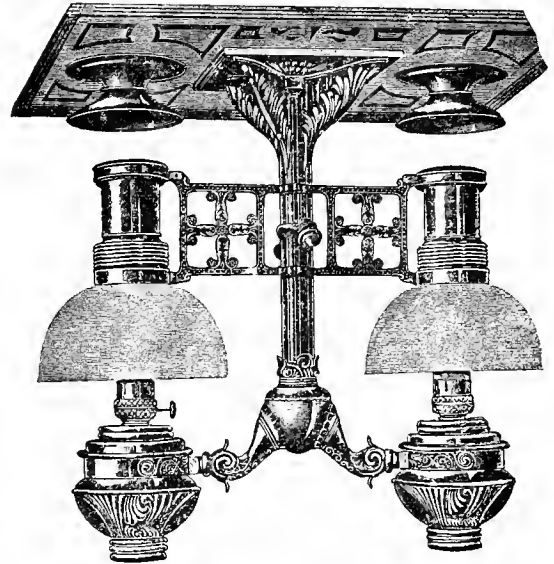

Fig. 3264. Two-fount Moehring Center-draft Dual Burner; Drop, 23 ins.

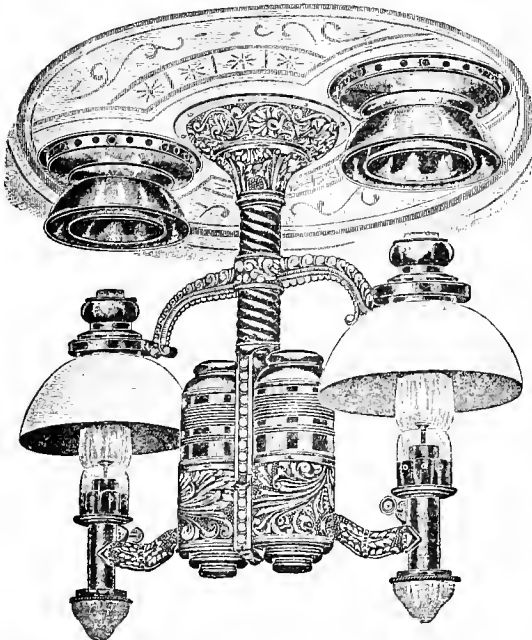

Fig. 3265. A Decorative Lamp for Dining, Parlor, Sleeping, and First-class Coaches.

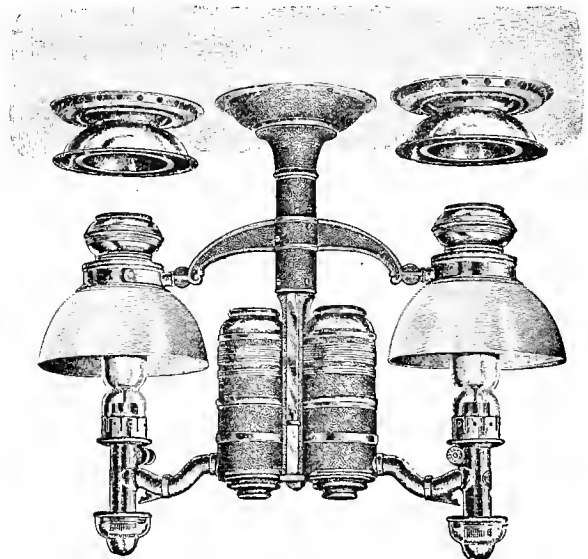

Fig. 3266. A Plain Lamp for Postal, Baggage, and Suburban Cars.

TWO-LIGHT OIL CHANDELIERS. Student-lamp Frames, Drop 26 ins., Acme Burners.

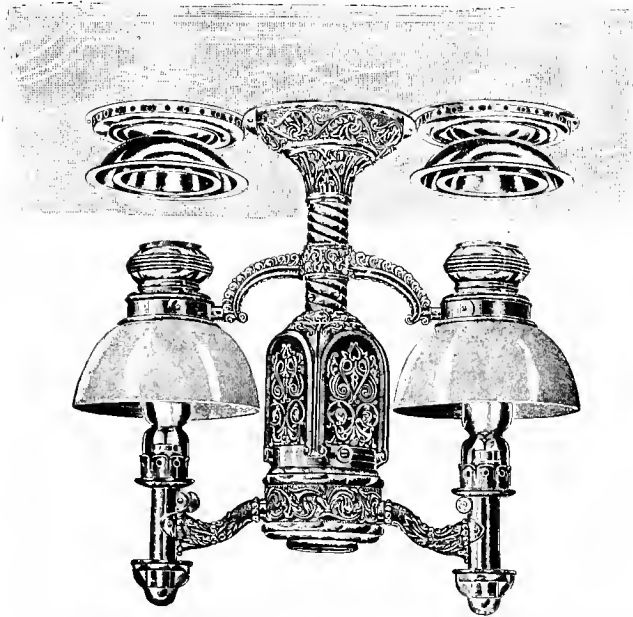

Fig. 3267. Single-fount. Drop, 26 ins. Acme Burners.

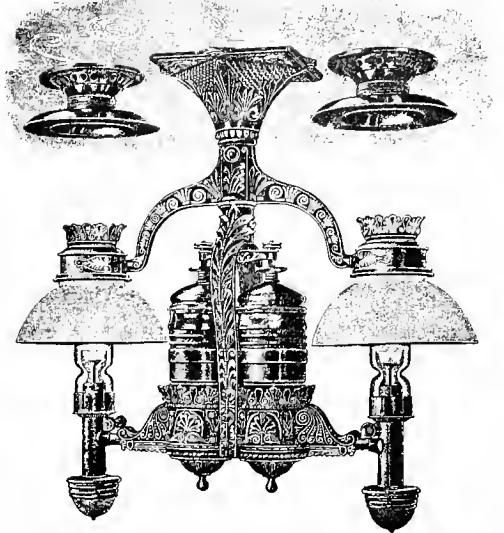

Fig. 3268. Two-founts. Drop, 23 1/2 ins. Student-lamp Principle

TWO-LIGHT OIL CHANDELIERS.

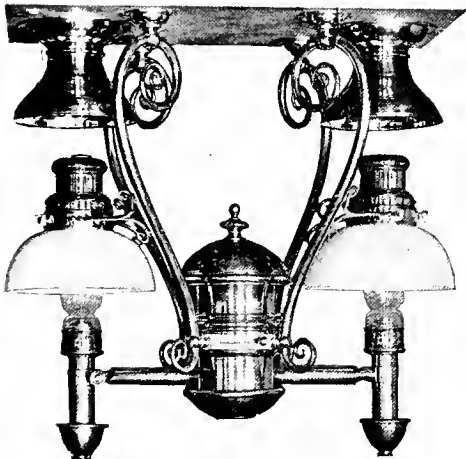

Fig. 3269. Two-light Oil Chandelier. Student-lamp Burners.

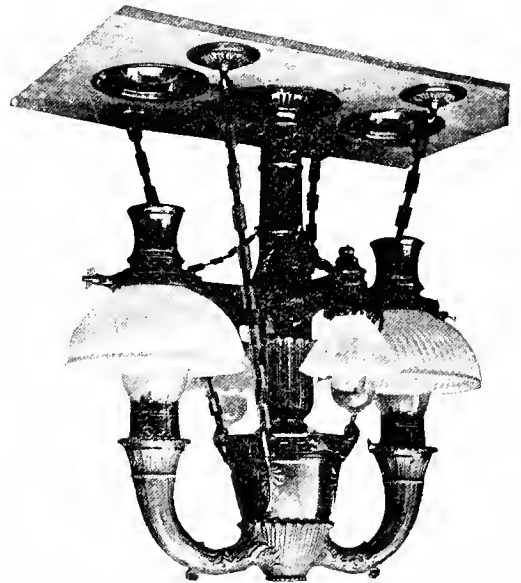

Fig. 3270. Two-light Oil and Two-light Electric Chandelier. (Pullman Pattern 1893.)

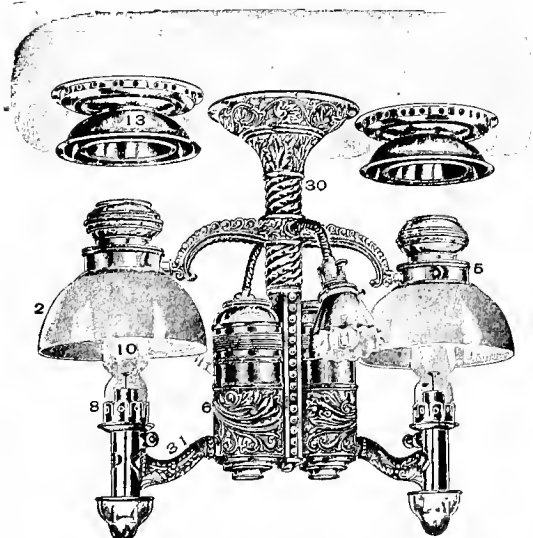

Fig. 3271. Acme-Burners. Drop, 26 in

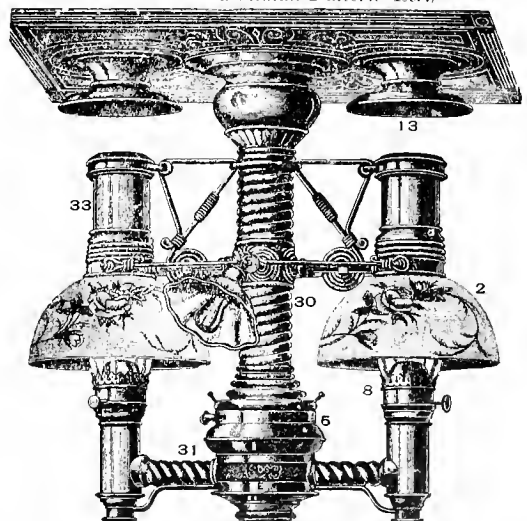

Fig. 3272. Dual-burners. Drop, 26 ins.

TWO-LIGHT OIL AND TWO-LIGHT ELECTRIC CHANDELIERS.

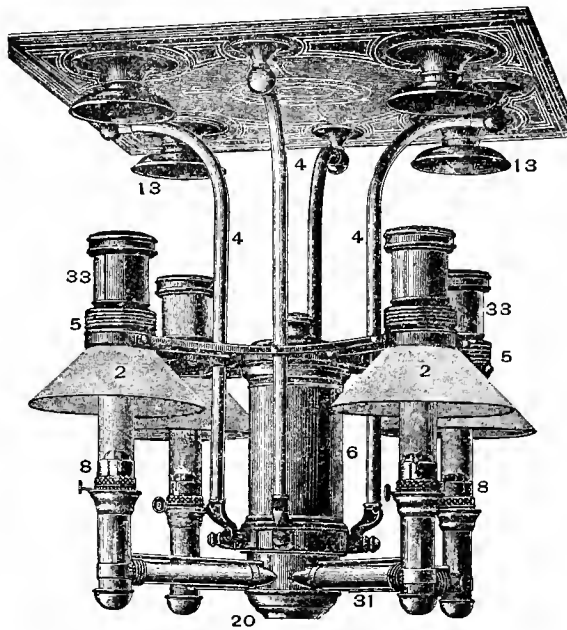

Fig. 3273. For Postal Cars.
One Oil Fountain. Mochring's Center-draft Burner.
Drop, 30 ins.

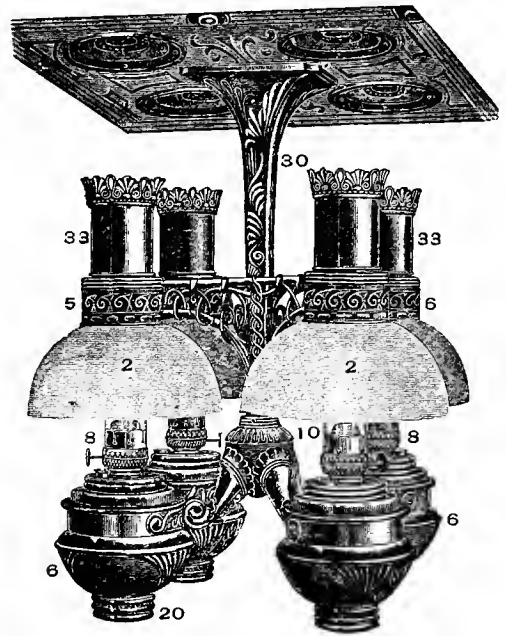

Fig. 3274. Four Oil Fountains.
Mochring Burners.
Drop, 26½ ins.

FOUR-LIGHT CHANDELIERS.

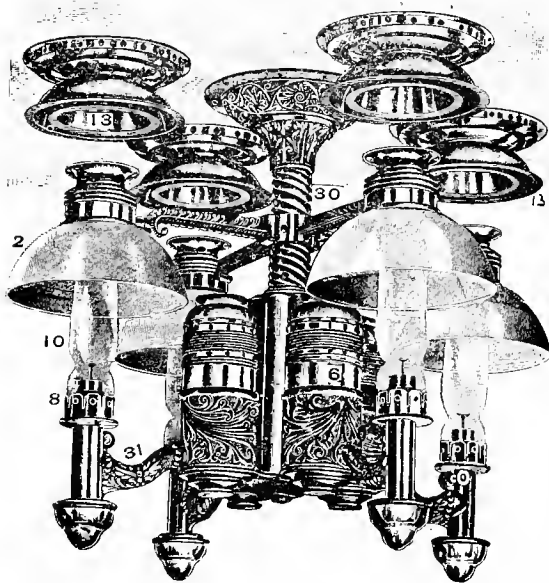

Fig. 3275. Four-light Chandelier for Private, Dining and Parlor Cars.
Drop, 26 ins. With Acme Burner, Glass Drip-cups, and Patent Combination Smoke-bell and Ventilator.

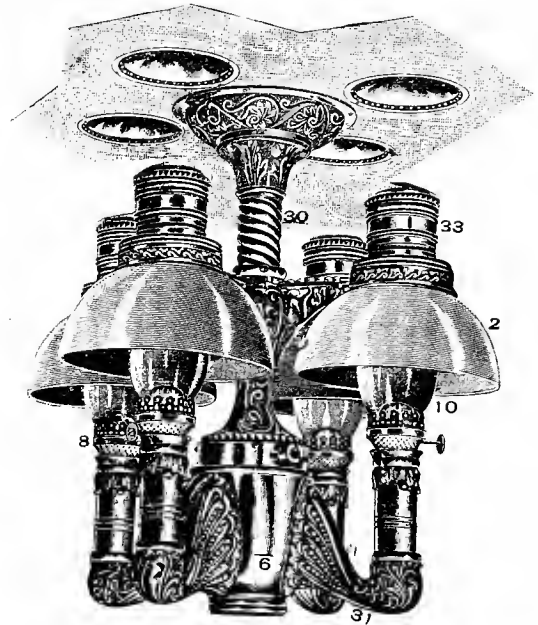

Fig. 3276. Four-light Chandelier.
Drop, 25½ ins.
One Oil-fountain and Dual Burners.

FOUR-LIGHT CHANDELIERS.

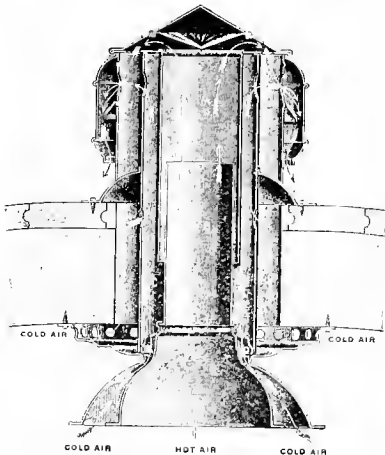
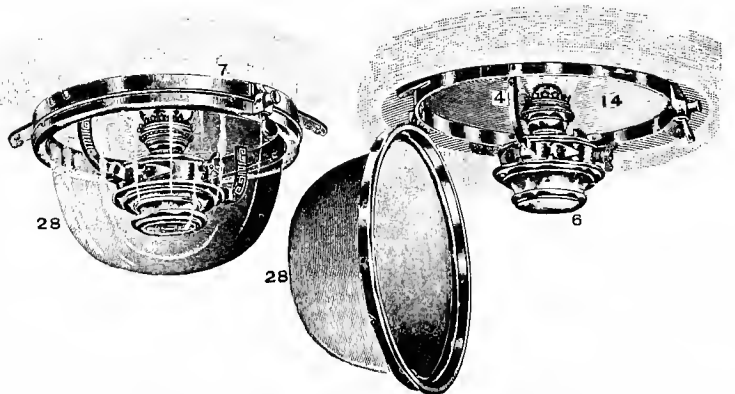

Fig. 3277. IMPROVED COMBINATION SMOKE-BELL AND VENTILATOR.



Figs. 3278-3279. VESTIBULE-DOME OR PLATFORM LAMP.
Diameter of Ring, 13 ins. Drop of Bowl, 7½ ins.



Fig. 3280. SIDE-LAMP.



Fig. 3281. CENTER-LAMP AND ELECTROLIER COMBINED.



Fig. 3282. SIDE-LAMP AND ELECTROLIER.

NAMES OF PARTS OF LAMPS, ETC. Figs. 3261-3317.

- | | | |
|--------------------|-----------------------|-------------------|
| 1. Lamp-stay. | 12. Lamp-chimney | 20. Lamp-bottom. |
| 2. Lamp-shade. | Bracket. | 21. Candle-holder |
| 3. Lamp-globe | 13. Smoke-bell | Cap. |
| Chimney. | 14. Lamp-reflector. | 22. Candle-holder |
| 4. Lamp-arms. | 15. Lamp-chimney | Cup. |
| 5. Lamp-ring. | Reflector. | 28. Lamp-globe. |
| 6. Lamp-reservoir. | 16. Side-lamp | 30. Center-stay. |
| 7. Globe-holder. | Holder. | 31. Feed-tube. |
| 8. Lamp-burner. | 17. Side-lamp | 33. Shade-cup. |
| 10. Lamp-chimney. | Bracket. | |
| 11. Lamp-chimney | 18. Side-lamp Braces. | |
| Holder. | | |

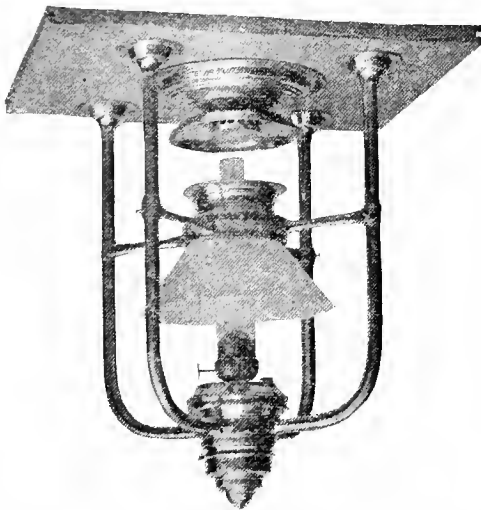

Fig. 3283. CENTER-LAMP. Drop, 22 ins. Mochring Center-draft Burner.

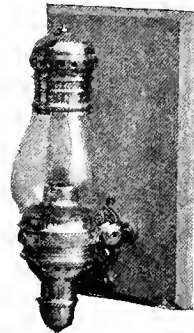

Fig. 3284. SIDE CANDLE-LAMP



Fig. 3285. BRACKET ELECTRIC LAMP.

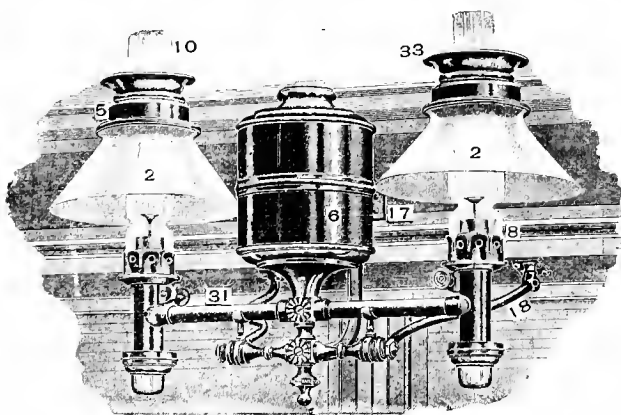

Fig. 3286. TWO-LIGHT SIDE DECK-LAMP. Acme Burners and Glass Drip-cups.

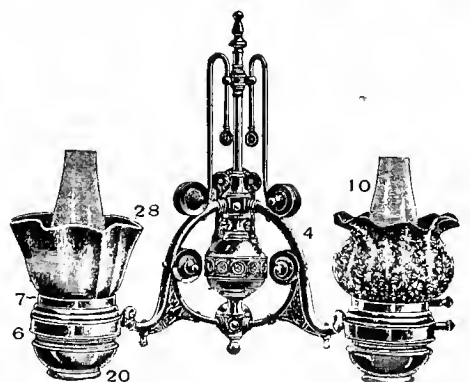

Fig. 3287. SHIP SIDE OR BRACKET-LAMP.

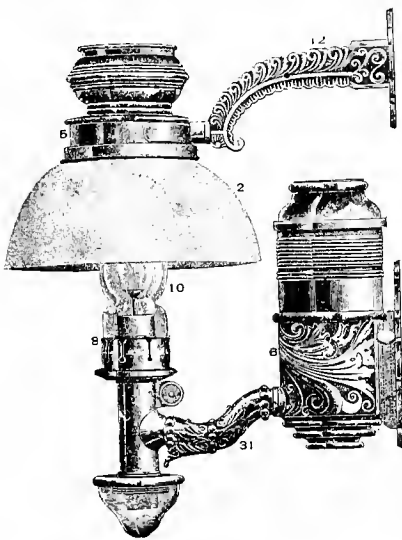

Fig. 3288. SIDE-LAMP.
With Acme Burner.

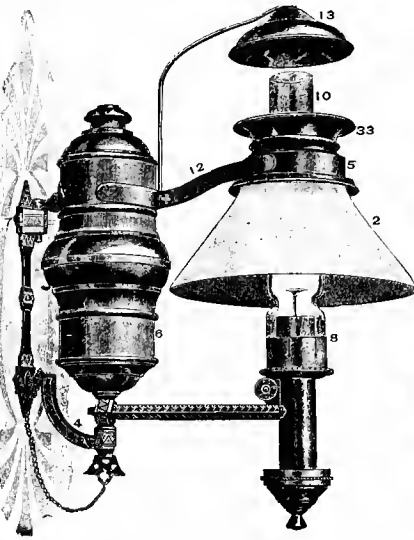

Fig. 3289. MAIL-CAR LAMP.
With Shade and Acme Burner.

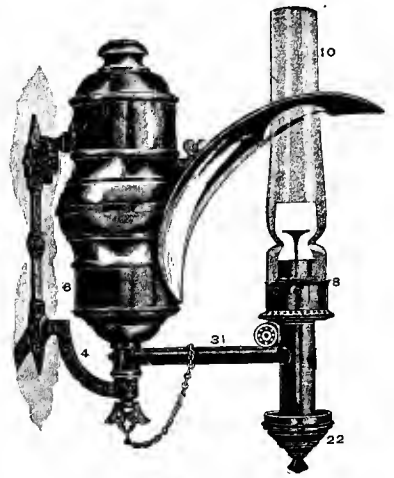

Fig. 3290. MAIL-CAR LAMP.
With Reflector and Acme Burner.

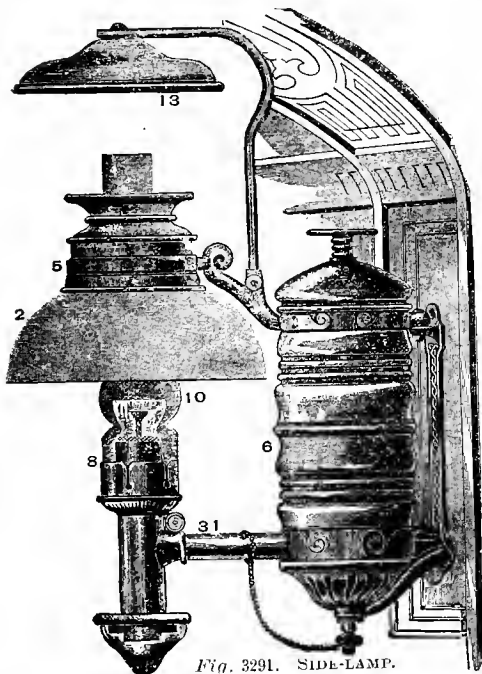

Fig. 3291. SIDE-LAMP.
With Acme Burner.

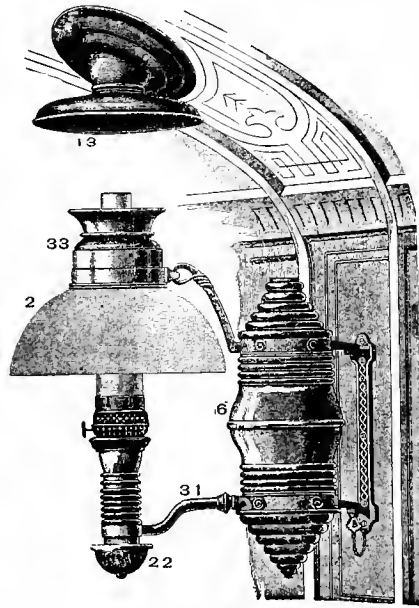

Fig. 3292. SIDE-LAMP.
With Moehring Center-draft Burner, Adjustable Triple-outlet Canopy.

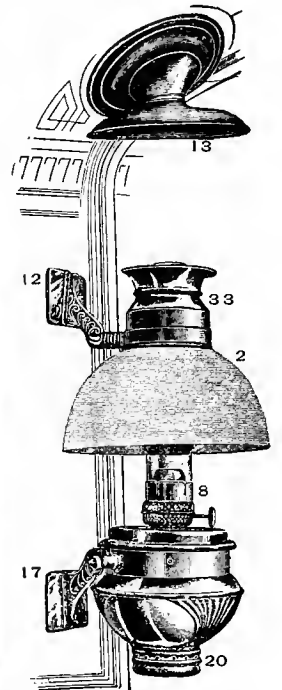

Fig. 3293. SIDE-LAMP.
With Moehring Center-draft Burner, Adjustable Canopy.



Fig. 3294.
SIDE CANDLE-LAMP.

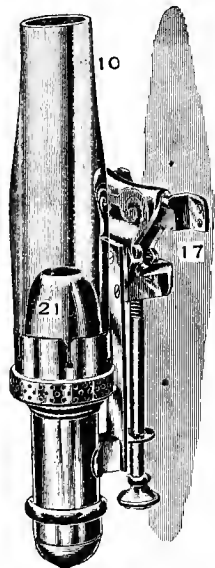

Fig. 3295. EMERGENCY SIDE
CANDLE-LAMP.

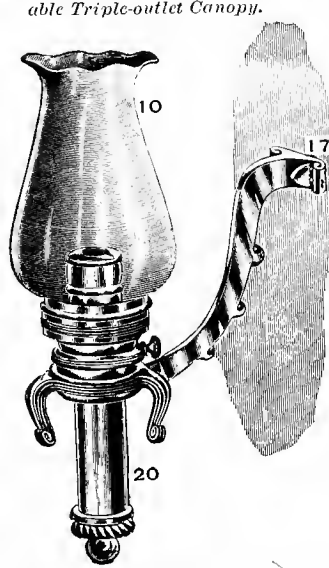

Fig. 3295. SIDE CANDLE-LAMP.

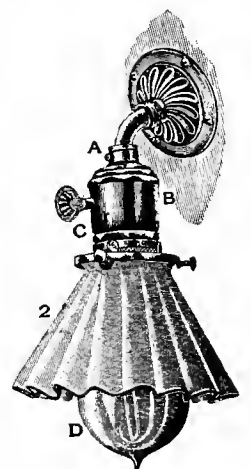

Fig. 3297.
BRACKET ELECTRIC LAMP.

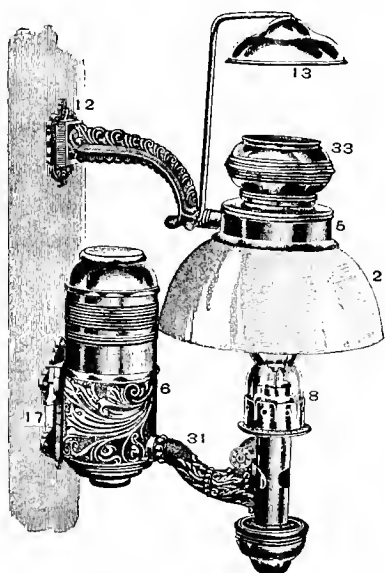

Fig. 3298. SIDE-LAMP.
To match Figs. 3265, 3275 and 3288.
Acme-burner.

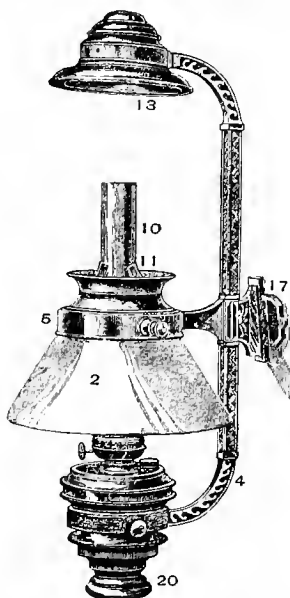

Fig. 3299. SIDE DECK-LAMP.
Mochring Center-draft
Burner.

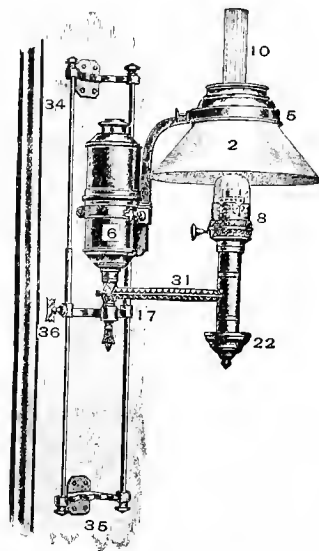

Fig. 3300. ADJUSTABLE BRACKET-LAMP.
Swivel-lamp Fount.



Fig. 3301. TORNADO
SIDE-LAMP.
Tubular construction.

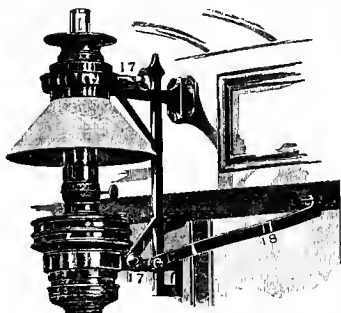

Fig. 3302. SIDE DECK-LAMP.
Plain cast fittings.

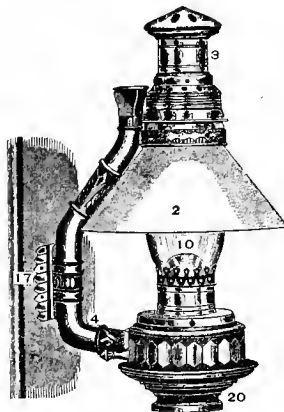

Fig. 3303. TORNADO SIDE-LAMP.
Tubular construction.

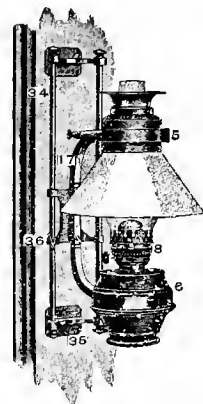

Fig. 3304. ADJUSTABLE
BRACKET-LAMP.



Fig. 3305. ONE-LIGHT CENTER
ELECTROLIER.

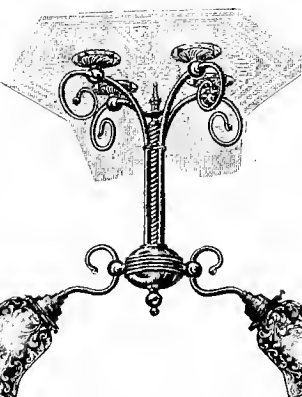

Fig. 3306. TWO-LIGHT CENTER
ELECTROLIER.

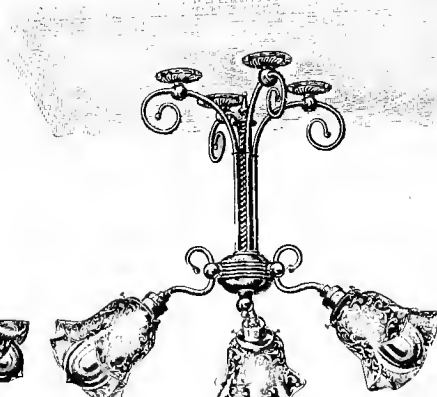

Fig. 3307. THREE-LIGHT CENTER
ELECTROLIER.

NAMES OF PARTS OF LAMPS, ETC. Figs. 3261-3317.

- | | | | |
|------------------------|---------------------------|-----------------------------|------------------------|
| 1. Lamp-stay. | 7. Globe-holder. | 14. Lamp-reflector. | 21. Candle-holder Cap. |
| 2. Lamp-shade. | 8. Lamp-burner. | 15. Lamp-chimney Reflector. | 22. Candle-holder Cup. |
| 3. Lamp-globe Chimney. | 10. Lamp-chimney. | 16. Side lamp Holder. | 28. Lamp-globe. |
| 4. Lamp-arms. | 11. Lamp-chimney Holder. | 17. Side-lamp Bracket. | 30. Center-stay. |
| 5. Lamp-ring. | 12. Lamp-chimney Bracket. | 18. Side-lamp Braces. | 31. Feed-tube. |
| 6. Lamp-reservoir. | 13. Smoke-bell. | 20. Lamp-bottom. | 33. Shade-cap. |

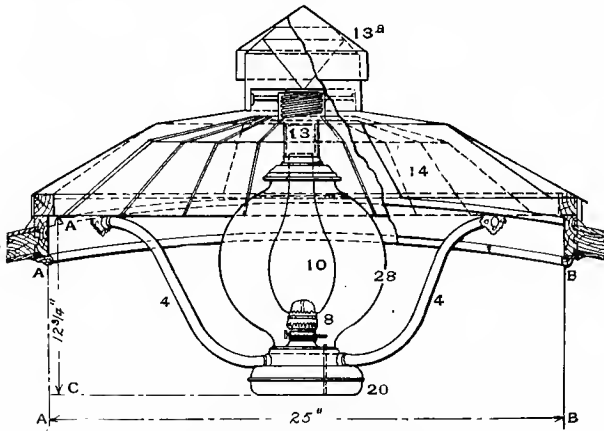

Fig. 3308. Sectional View.
STREET-CAR CENTER-LAMP.

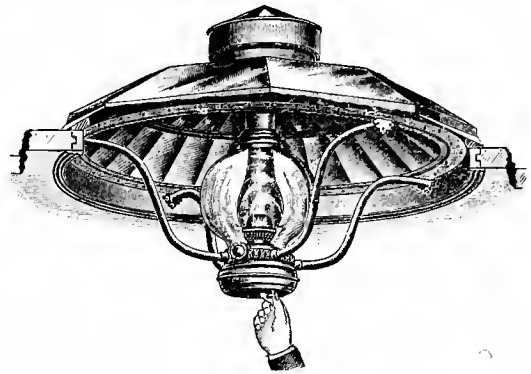

Fig. 3309. STREET-CAR CENTER-LAMP.
Spread of arms, 25 ins. Drop, 12 3/4 ins.

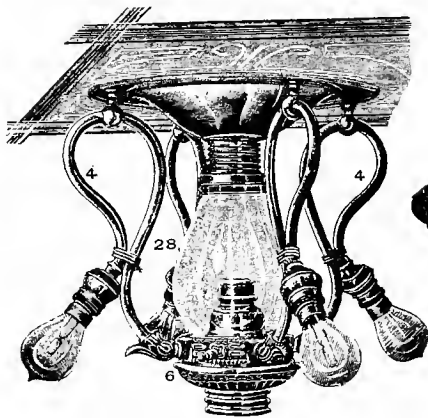

Fig. 3310. CANDLE CENTER-LAMP AND
ELECTROLIER.
Drop, 14 1/2 ins.

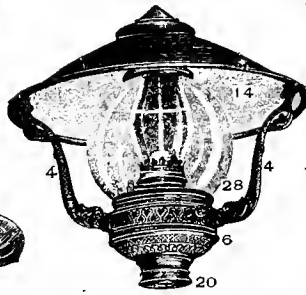

Fig. 3311. VESTIBULE OR
PLATFORM LAMP.
Drop, 16 ins. Enamelled reflector.

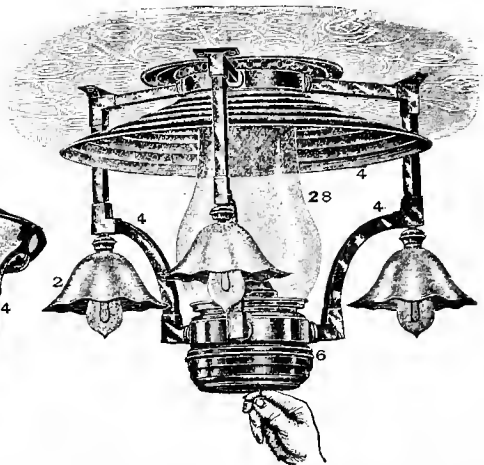

Fig. 3312. OIL CENTER-LAMP AND ELECTROLIER.
Three hangers. Nickeline reflector.

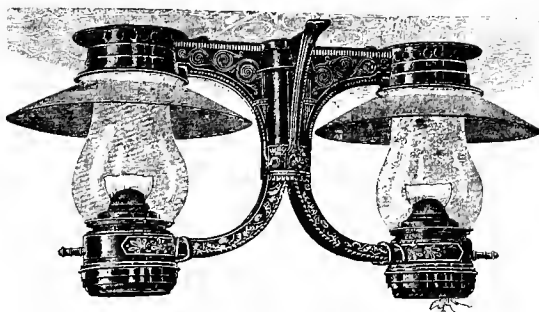

Fig. 3313. TWO-LIGHT CHANDELIER FOR STREET-CARS.
Spread of Burners, 19 3/4 ins.

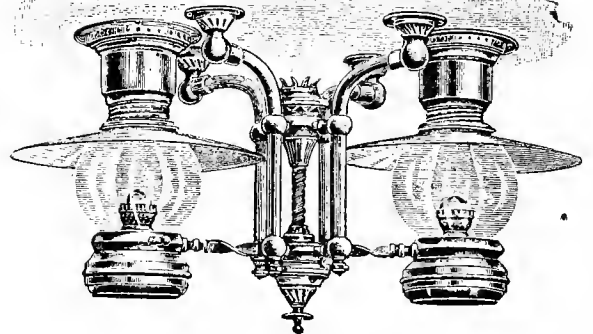

Fig. 3314. TWO-LIGHT CHANDELIER.
J. M. B. Two-spring Burners. Drop, 16 ins.

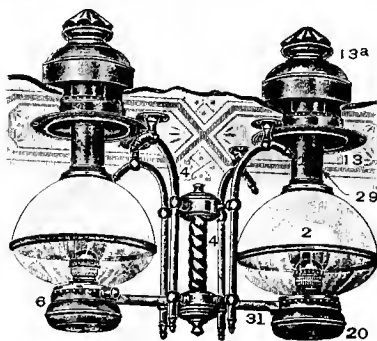

Fig. 3315. TWO-LIGHT CHANDELIER FOR
CABLE-CARS.
Drop, 15 ins.

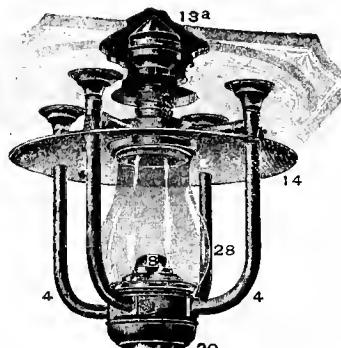

Fig. 3316. CENTER-LAMP.
Four-arm Drop.



Fig. 3317. CENTER-LAMP.
Drop, 15 ins.
Two-spring or Dual Burner.

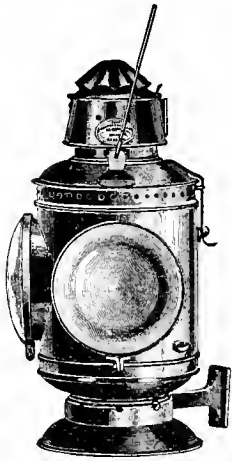

Fig. 3318.
ENGINE-LAMP WITH TWO LENSES.

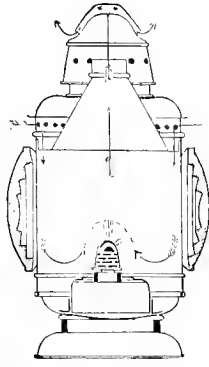

Fig. 3319.
WATT'S UPPER-DRAFT VENTILATED TAIL-LAMP.

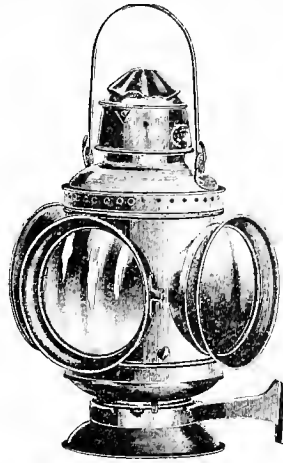

Fig. 3320.
COACH TAIL-LAMP WITH THREE OR FOUR LENSES.

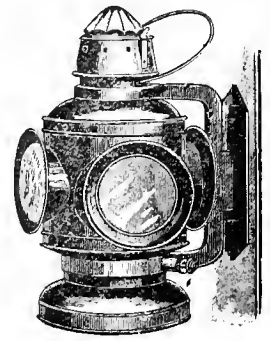

Fig. 3321.
PASSENGER AND CABOOSE TAIL-LAMP.

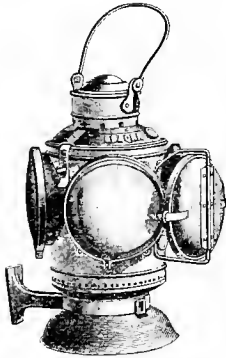

Fig. 3322.

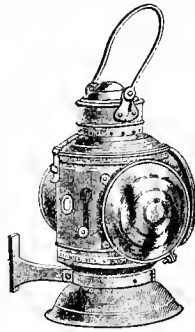

Fig. 3323.
The Blizzard Lamp.

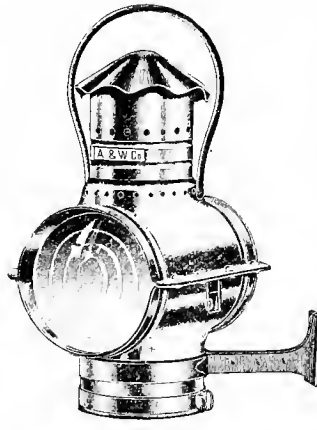

Fig. 3324.

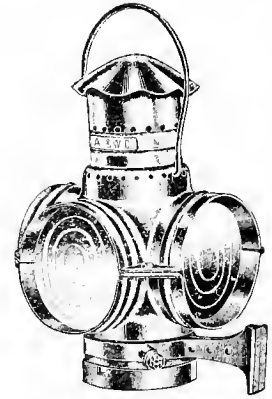
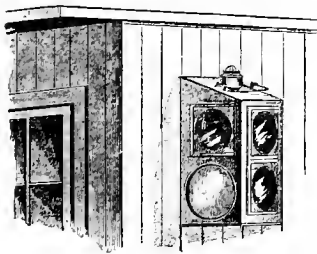

Fig. 3325.

COACH AND CABOOSE TAIL-LAMPS.
Made from two pieces of sheet-steel

COACH AND CABOOSE TAIL-LAMPS.
THE RAILROAD SIGNAL LAMP AND LANTERN COMPANY.



Attachment to caboose.

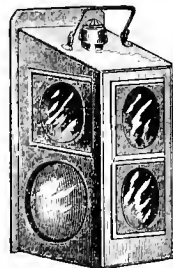

Figs. 3326-3328.
Lamp detached.

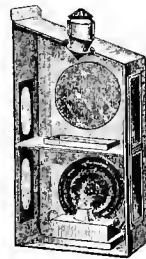

Lamp interior.

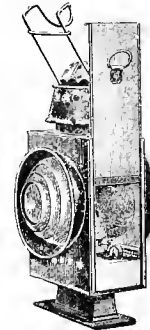

Fig. 3329.
TAIL-LAMP.
3 3/4 in. semaphore lenses.

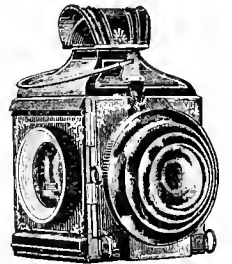

Fig. 3330.
PLATFORM TAIL-LAMP.
8 3/4 in. lens.

THE WATT COMBINATION CABOOSE TAIL-LAMP.
Two stories showing different colored lights.

NAMES OF PARTS OF LAMPS, ETC. Figs. 3261-3317.

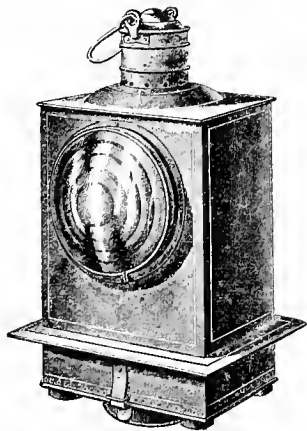

Fig. 3331.

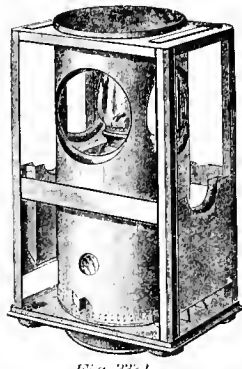
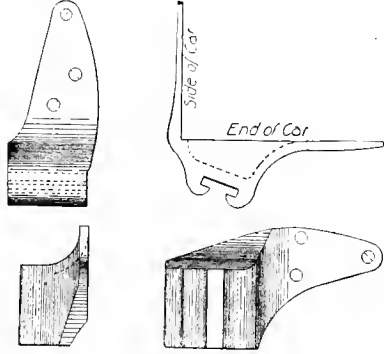
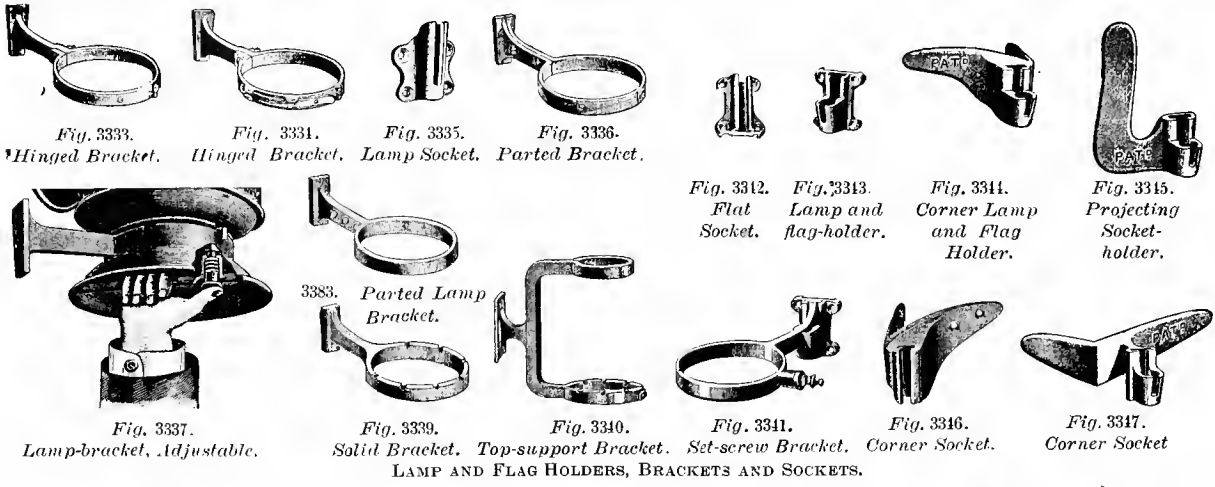

Fig. 3332.

PLATFORM TAIL-LAMP.

- | | |
|---------------------------|-----------------------------|
| 1. Lamp-stay. | 14. Lamp-reflector. |
| 2. Lamp-shade. | 15. Lamp-chimney Reflector. |
| 3. Lamp-globe Chimney. | 16. Side-lamp Holder. |
| 4. Lamp-arms. | 17. Side-lamp Bracket. |
| 5. Lamp ring. | 18. Side-lamp Braces. |
| 6. Lamp-reservoir. | 20. Lamp-bottom. |
| 7. Globe-holder. | 21. Candle-holder Cap. |
| 8. Lamp-burner. | 22. Candle-holder Cup. |
| 10. Lamp-chimney. | 28. Lamp-globe. |
| 11. Lamp-chimney Holder. | 30. Center-stay. |
| 12. Lamp-chimney Bracket. | 31. Feed-Tube. |
| 13. Smoke-bell. | 33. Shade-cap. |



Figs 3348-3351
Bracket for Tail-lamp.

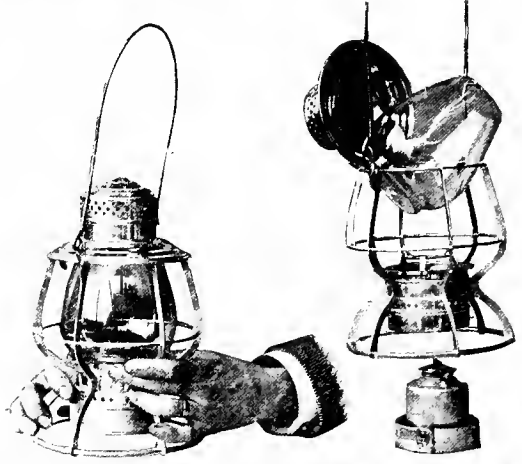

Figs. 3352-3354. Manner of Taking A. & W. Lantern Apart.



Fig. 3355. The Adams Lantern.
Twisted Steel Ears.

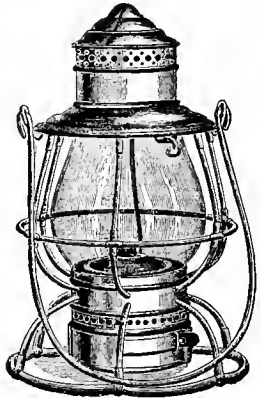

Fig. 3356.
The Giant Lantern.



Fig. 3357.
The "Pullman" Pattern.



Fig. 3358.
The "Quincy" Pattern.

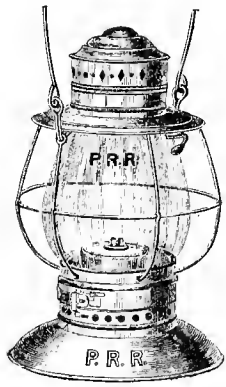

Fig. 3359.
"Pennsylvania" Pattern.



Fig. 3360.
"Rock Island" Pattern.

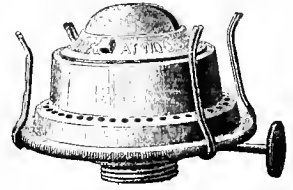
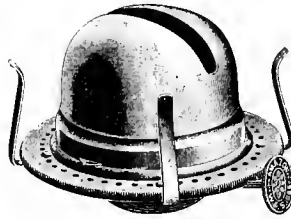
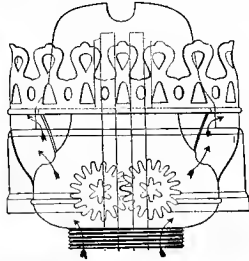
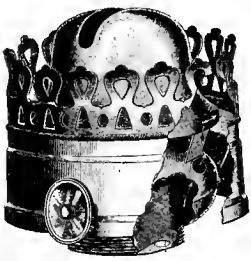

Fig. 3361. Steamboat Lantern
guarded with Heavy Wire.



Fig. 3362.
Steamboat Lantern.

RAILROAD LANTERNS.



Figs. 3363-3364. Sectional Views.
IMPROVED DUAL BURNERS, WITH SKIRT.

Fig. 3365. AMAZON BURNER.

Fig. 3366. FIRESIDE BURNER.

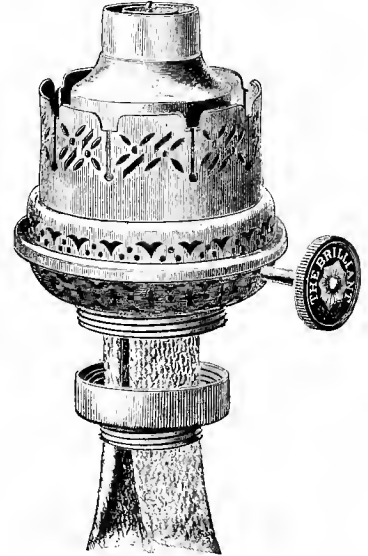
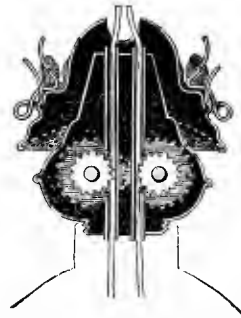
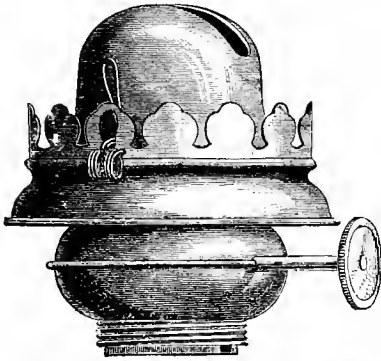

Fig. 3367. DUAL BURNER. (2/3 full size.)

Fig. 3368. SECTION OF DUAL BURNER.

Fig. 3369.
"BRILLIANT" ARGAND BURNER.
(2/3 full size.)

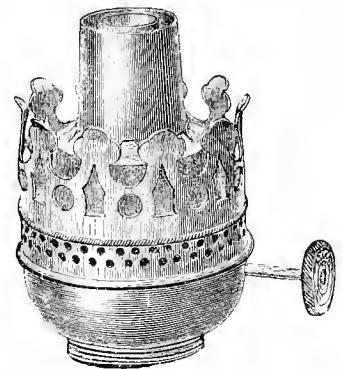
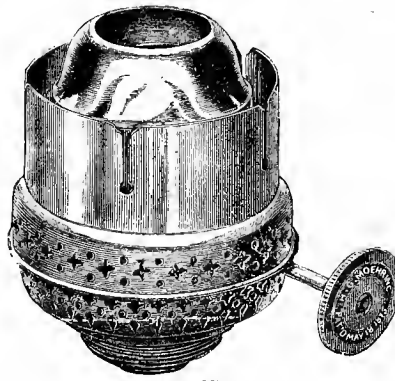
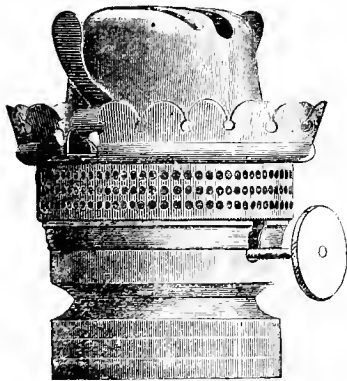

Fig. 3370.
TWO-SPRING SLIP BURNER, FOR
STREET-CAR LAMPS.

Fig. 3371.
MOEHRING ARGAND BURNER.
(2/3 full size.)

Fig. 3372.
ASTRAL ARGAND BURNER.

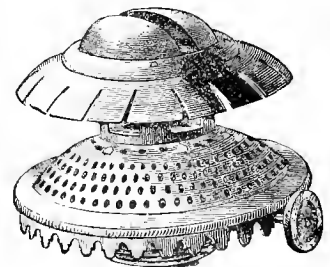
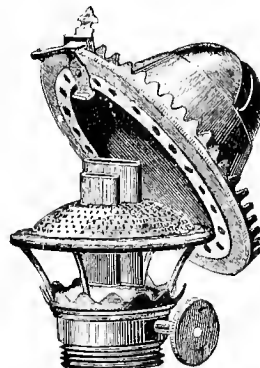

Fig. 3373.
"SUN-HINGE" BURNER.
(Sun-hinge Chimney, Nos. 14 and 17.)

Fig. 3374
SUN-HINGE BURNER.

Fig. 3375.
SUN BURNER.
(Original Form.)

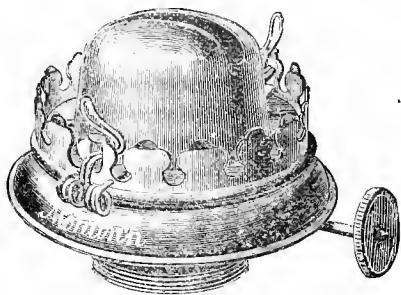

Fig. 3376. "MONARCH" BURNER ($\frac{2}{3}$ full size).
(Nos. 2, 3 and 18 Chimneys.)

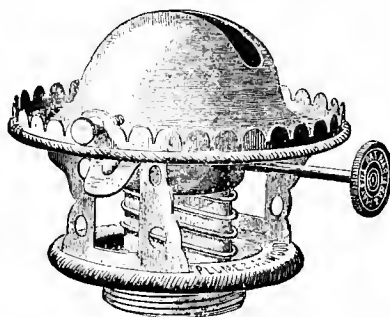

Fig. 3377. "UNIQUE" SUN-HINGE BURNER.
(Sun-hinge Chimney, Nos. 14 and 17.)

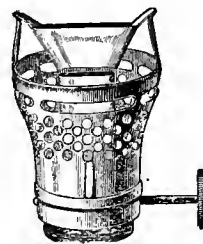

Fig. 3378. "ALADDIN."
Long Body.

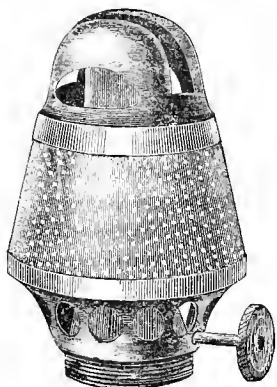

Fig. 3379. "SAVAGE."
SIGNAL-LAMP BURNERS, NO CHIMNEY REQUIRED.



Fig. 3380. "CHAMPION."
SIGNAL-LAMP BURNERS, NO CHIMNEY REQUIRED.

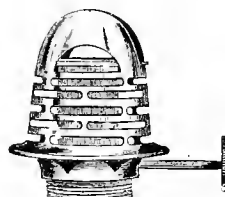

Fig. 3381. "CALLENDER."
SIGNAL-LAMP BURNERS.

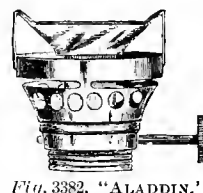

Fig. 3382. "ALADDIN."
Short Body.



Fig. 3383.
CANDLE-BOTTOM.

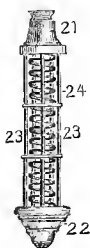

Fig. 3384.
CANDLE-HOLDER.

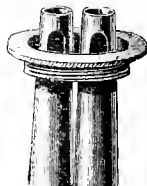

Fig. 3385.
OIL-SCREWS, TUBED.

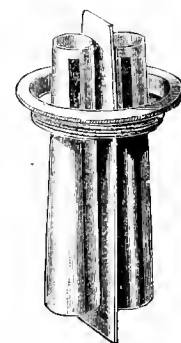

Fig. 3386.
OIL-SCREWS, TUBED, WITH
HEATER-PLATE

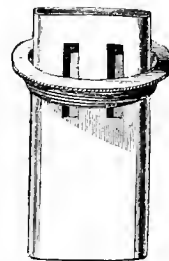
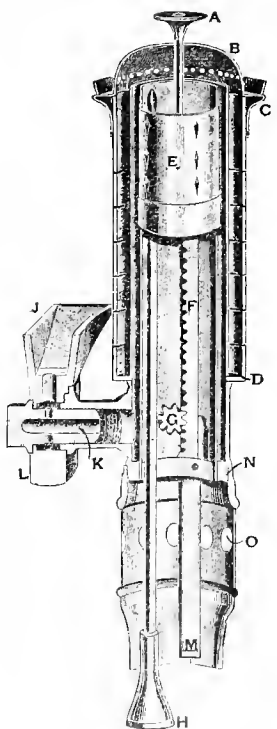
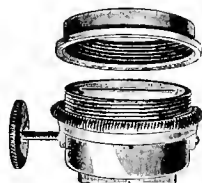
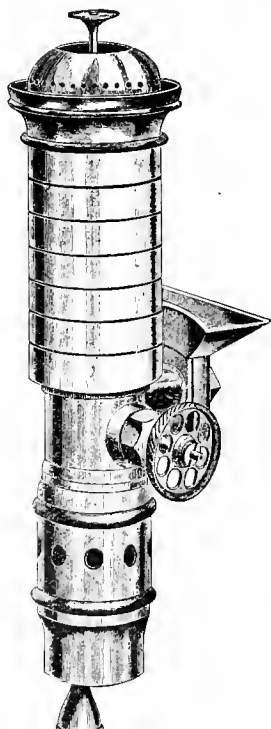

Fig. 3387.
LARD-LAMP SCREW



Figs. 3388-3389.
HEAD-LIGHT BURNER,
The Davis Patent.



Figs. 3391-3391.
REDUCING-COLLAR.



Fig. 3392.
LAMP-COLLAR.



Fig. 3393.
SOLID LAMP-HOOP.



Figs. 3394-3395.
FEEDER-CUP AND COLLAR.

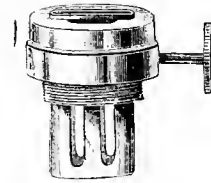

Fig. 3396.
LARD-OIL RATCHET
BURNER.

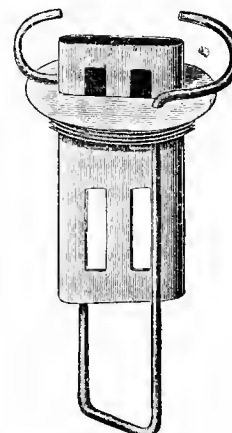

Fig. 3397.
MINOT HEATING
BURNER. (274)

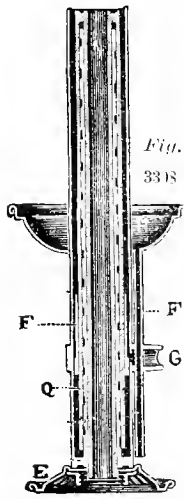

Fig. 3398

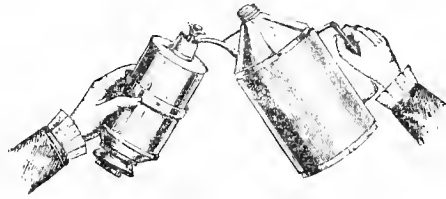

Fig. 3402. FILLING OF RESERVOIR.

Fig. 3401.



Fig. 3404. OIL-SCREW. (Hollow.)



Fig. 3403. REDUCING COLLAR.

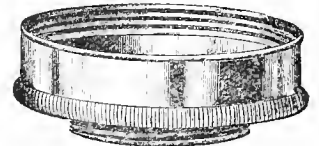
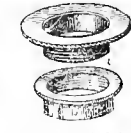

Fig. 3405. EXPANDING COLLAR.



Figs. 3406-7. OIL-SCREW AND HOOP.



Fig. 3408. OIL-SCREW. (Made blank or pierced.)



Figs. 3409-10. FEEDER-SCREW AND HOOP.



Fig. 3411. OIL-LAMP HOOP.

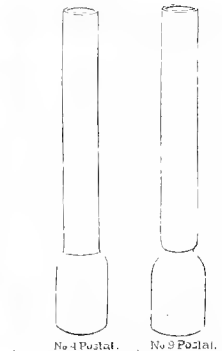

Fig. 3412. Fig. 3413. STUDENT-LAMP CHIMNEYS.

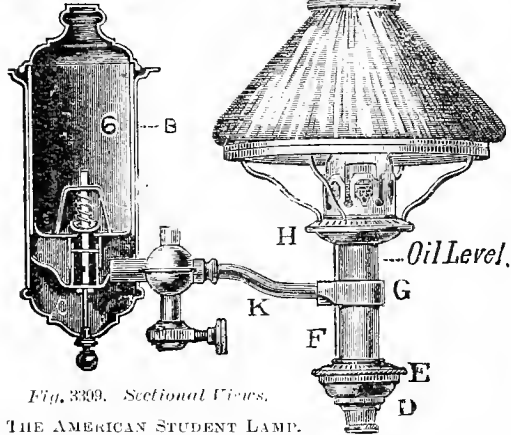

Fig. 3399. Sectional Views. THE AMERICAN STUDENT LAMP. (An old pattern.)

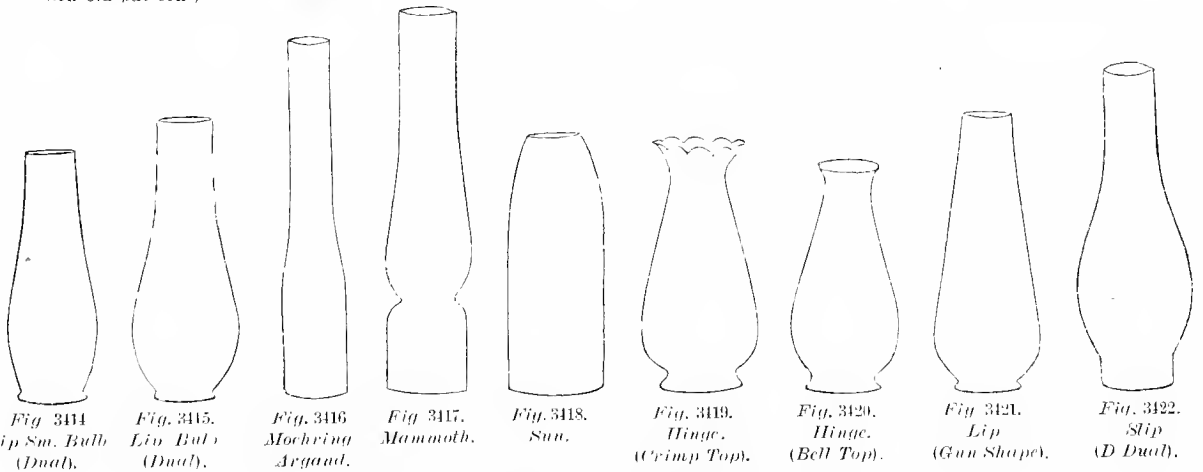

Fig. 3414 Lip Sm. Bulb (Dual). Fig. 3415 Lip Bulb (Dual). Fig. 3416 Mochring Argand. Fig. 3417 Mammoth. Fig. 3418 Sun. Fig. 3419 Hinge (Crimp Top). Fig. 3420 Hinge (Bell Top). Fig. 3421 Lip (Gun Shape). Fig. 3422 Slip (D Dual).

STANDARD STYLES OF LAMP CHIMNEYS.

(The use of these Standards in the trade is general, but not universal.)

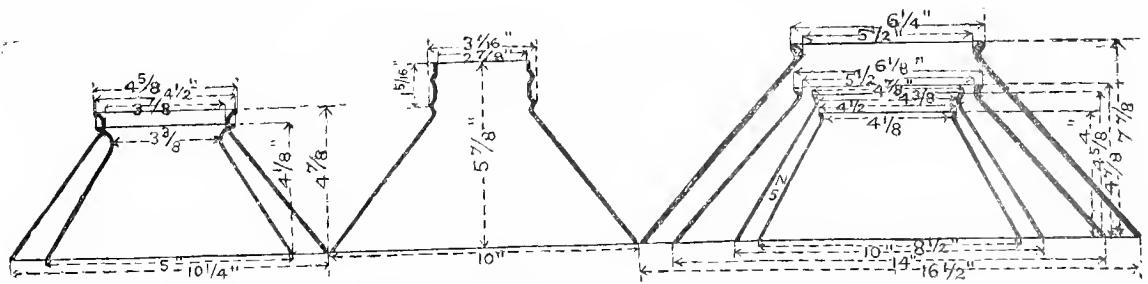

Fig. 3423.

Fig. 3424. CONE SHADES.

Fig. 3425.

STANDARD STYLES OF LAMP SHADES.

(The use of these Standards in the trade is general, but not universal.)

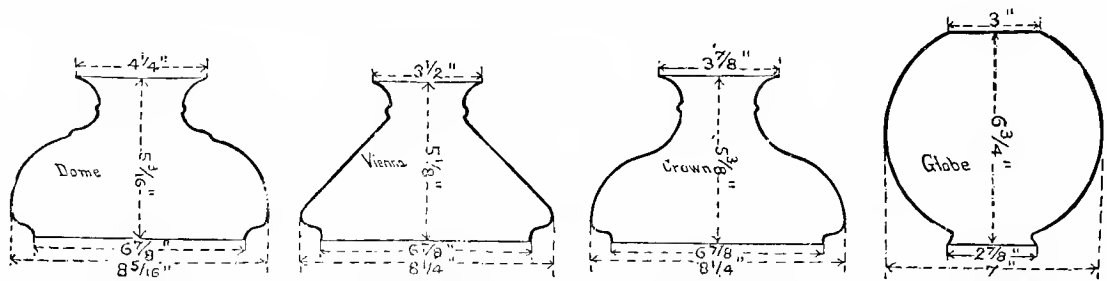

Fig. 3426. "DOME" LAMP-SHADE. Fig. 3427. "VIENNA" LAMP-SHADE. Fig. 3428. "CROWN" LAMP-SHADE. Fig. 3429. "GLOBE" LAMP-SHADE OR LAMP-GLOBE.

STANDARD STYLES OF LAMP-SHADES: SPECIAL FORMS FOR STUDENT AND OTHER LAMPS.
(The use of these Standards in the trade is general, but not universal.)

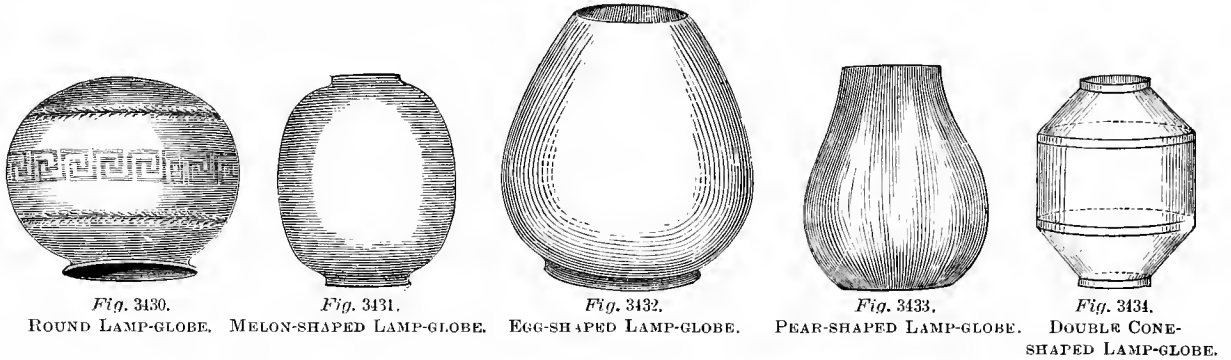

Fig. 3430. ROUND LAMP-GLOBE. Fig. 3431. MELON-SHAPED LAMP-GLOBE. Fig. 3432. EGG-SHAPED LAMP-GLOBE. Fig. 3433. PEAR-SHAPED LAMP-GLOBE. Fig. 3434. DOUBLE CONE-SHAPED LAMP-GLOBE.

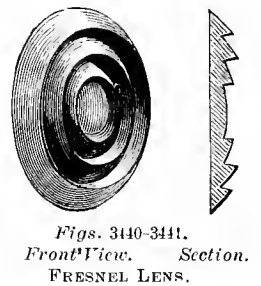
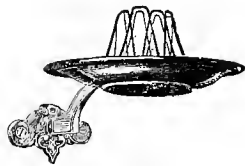
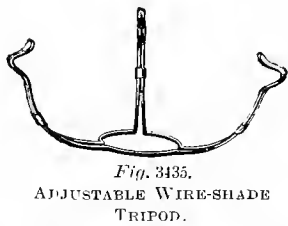

Fig. 3438. CANOPY. Top diameter, 3 ins.; bottom diameter, 7 3/4 ins.



Fig. 3439. SMOKE-BELL AND SMOKE-BELL BRACKET. 7 1/2 in. diameter.



Figs. 3442-3443. SEMAPHORE LENS. Section. Front View. (A modified form of the Fresnel Lens.)

NAMES OF PARTS. Fig. 3468.

- | | | |
|-----------------------|--------------------------|--------------------------|
| 1. Tank. | 7. Mirror. | 13. Basin-pump Rod. |
| 2. Wash-basin. | 8. Basin-pump Lever. | 14. Water Cooler. |
| 3. Slab. | 9. Basin-pump Post. | 15. Towel-box. |
| 4. Basin-pump Handle. | 10. Basin-pump Case. | 16. Comb and Brush-rack. |
| 5. Basin-pump Nozzle. | 11. Basin-pump Pipe. | 17. Tumbler Holder. |
| 6. Soap Dish. | 12. Basin-pump Strainer. | 18. Cuspidore. |



Fig. 3444. Diam. 6 3/4 ins.



Fig. 3445. Diam. 6 ins.



Fig. 3446. Diam. 7 ins.



Fig. 3447. Diam. 4 1/2 ins. Adjustable.

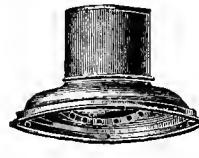

Fig. 3448. Diam. 7 3/4 ins.



Fig. 3449. Diam. 9 ins. Kirby's Adjustable.

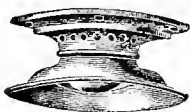

Fig. 3450. Diam. 7 1/8 ins.

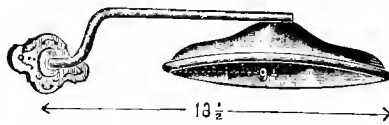

Fig. 3451. Bracket Canopy. 13 1/2



Fig. 3452. Sectional View.



Fig. 3453. Diam. 5 3/4 ins.

LAMP CANOPIES OR SMOKE BELLS.

Numbers refer to List of Names on Preceding Page.



Fig. 3468. General Interior View.

LAVATORY OF A SLEEPING-CAR FOR MEN.

(A prevailing system that is being replaced by that shown in *Figs. 3525-3540.*)

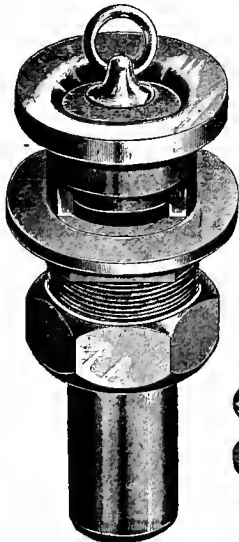

Fig. 3469. BASIN-BUSHING AND PLUG FOR OVERFLOW-BOWL.



Fig. 3470. SINK-BUSHING AND PLUG.

Fig. 3471. BASIN-BUSHING AND PLUG.



Fig. 3472. TAIL-COUPLING FOR ALCOVE-FAUCET.



Fig. 3473. TUMBLER-HOLDER AND DRIP.

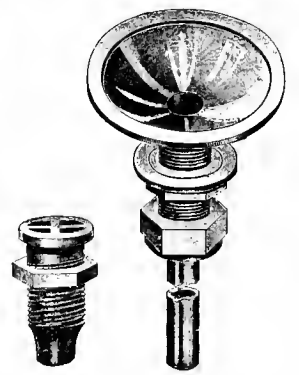

Fig. 3474. DRIP COUPLINGS.

Fig. 3475. WATER-COOLER DRIP AND CONNECTIONS.

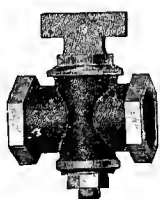

Fig. 3476.



Fig. 3477.

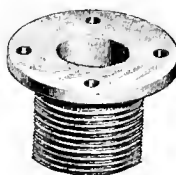

Fig. 3478. SPUD.



Fig. 3479. SPUD AND COUPLING.

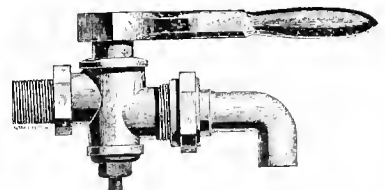

Fig. 3480. COMBINATION COCK FOR BAKER HEATERS.

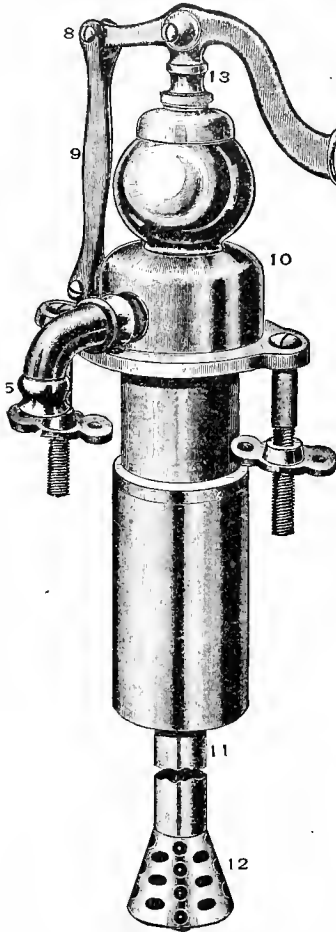

Fig. 3481.

WASH-ROOM PUMPS.

Numbers refer to Names of Parts with Figs. 3426-3453.

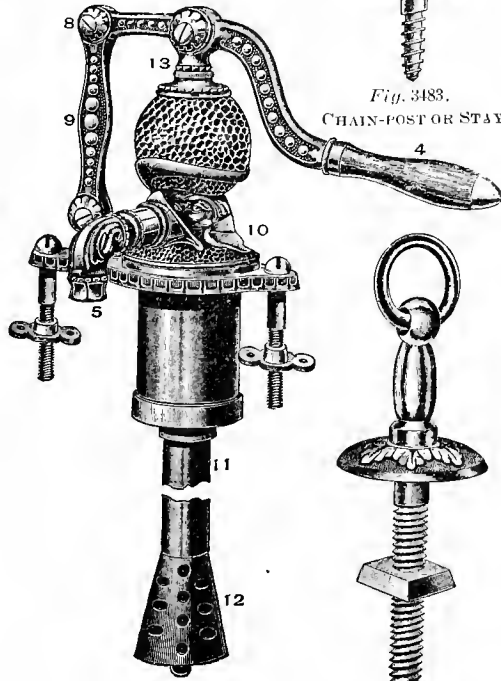

Fig. 3482.



Fig. 3483. CHAIN-POST OR STAY.



Fig. 3484. CHAIN-POST OR STAY.

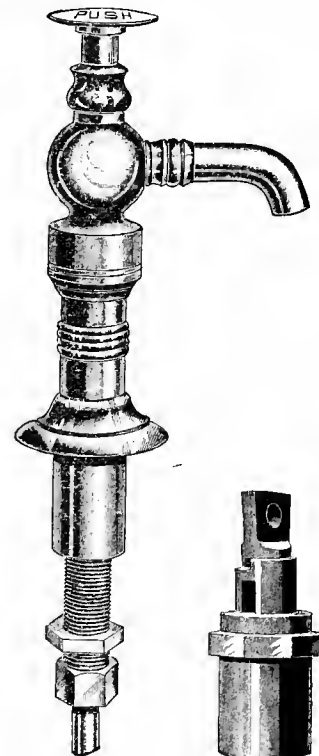

Fig. 3485. COMPRESSION FAUCET.

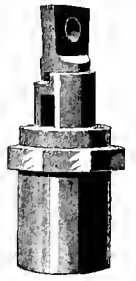

Fig. 3486. TANK WASTE-COCK.



Fig. 3487. SPIDER.



Fig. 3488. WRENCH.



Fig. 3489. TELEGRAPH FAUCET (Decorated).

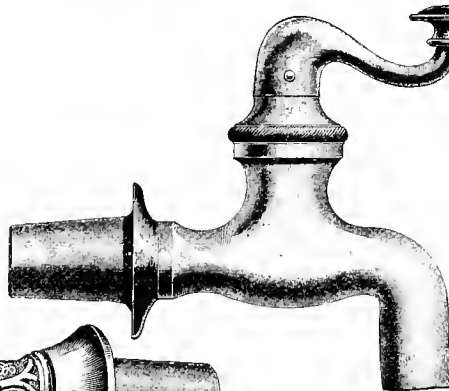

Fig. 3490. TELEGRAPH FAUCET.

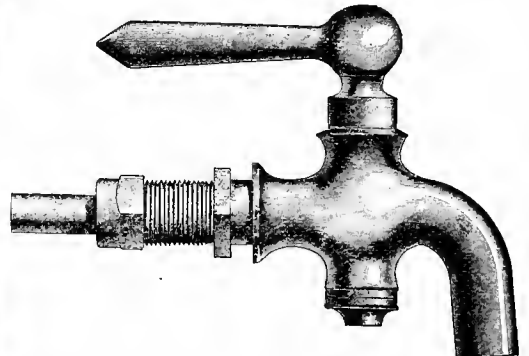

Fig. 3491. BIBB-COCK.

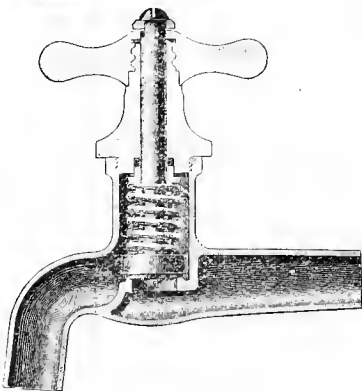

Fig. 3492. ZANE'S SELF-CLOSING BIBB-COCK.

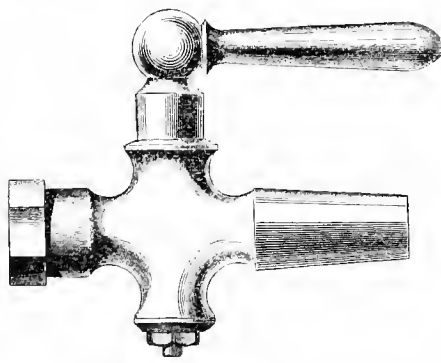

Fig. 3493. STOP-COCK.

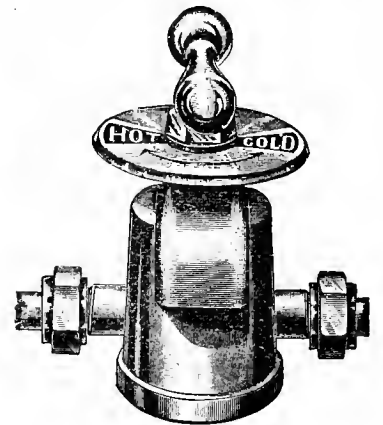

Fig. 3494. HITCHCOCK'S COMBINATION HOT-AND-COLD WATER FAUCETS. (278)



Fig. 3495. TUMBLER-HOLDER.

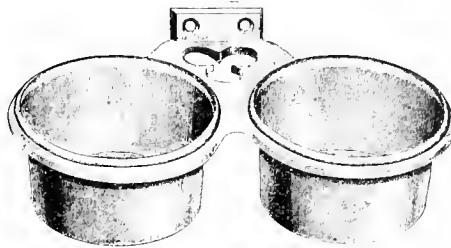

Fig. 3496. DOUBLE TUMBLER-HOLDER.



Fig. 3497. TUMBLER-HOLDER.

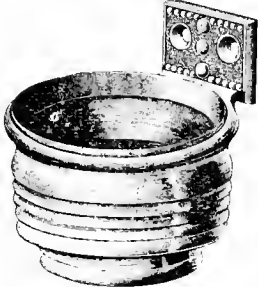

Fig. 3498.

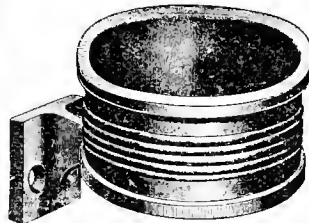

Fig. 3499. TUMBLER-HOLDERS.

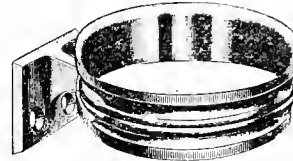

Fig. 3500.

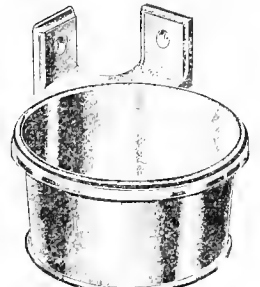

Fig. 3501.

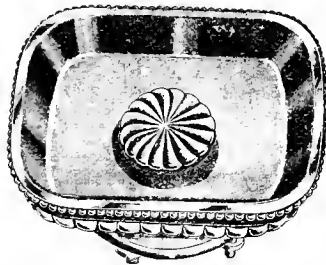

Fig. 3502. Top View of Fig. 3501.
Size, $3\frac{3}{8}$ - $4\frac{3}{8}$ ins.

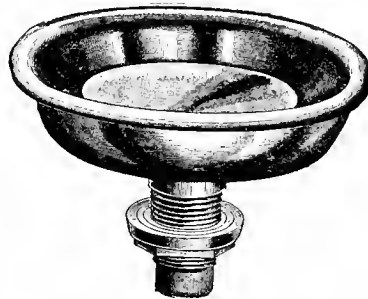

Fig. 3503.
 $4\frac{1}{2}$ ins. in diameter.

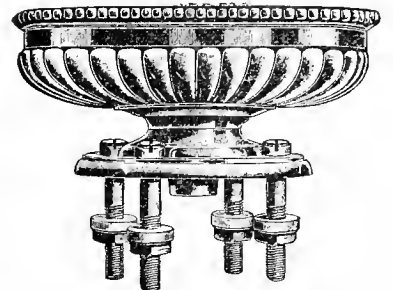

Fig. 3504. Side View of Fig. 3502.
Size, $3\frac{3}{8}$ - $4\frac{3}{8}$ ins.

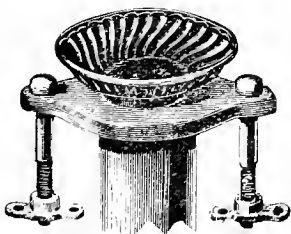

Fig. 3505.

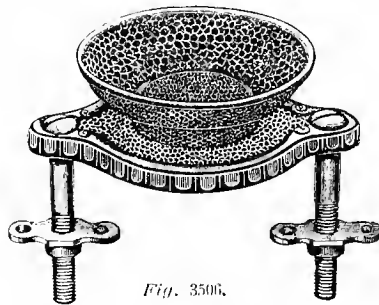

Fig. 3506.
SOAP-DISHES.
Center to Center of Bolts, 5 ins.

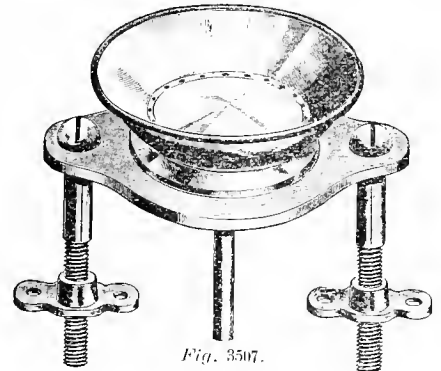

Fig. 3507.

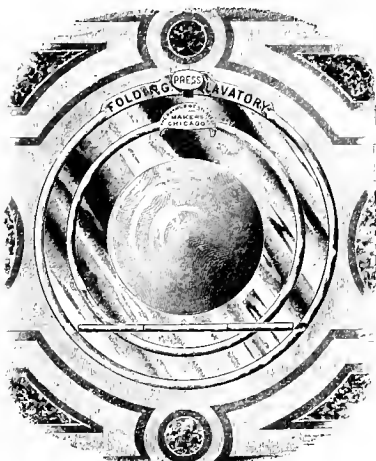

Fig. 3508. Closed.

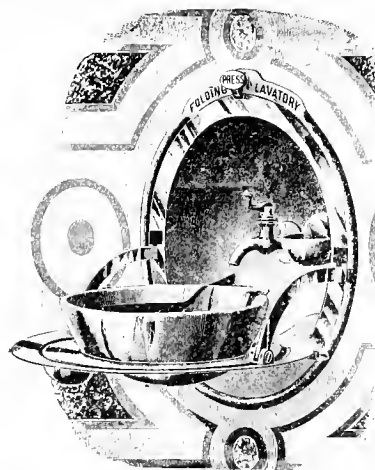

Fig. 3509. Open.

FOLDING LAVATORY OR WASH-BASIN.

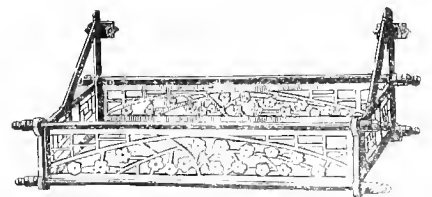

Fig. 3510.
COMB AND BRUSH RACK.

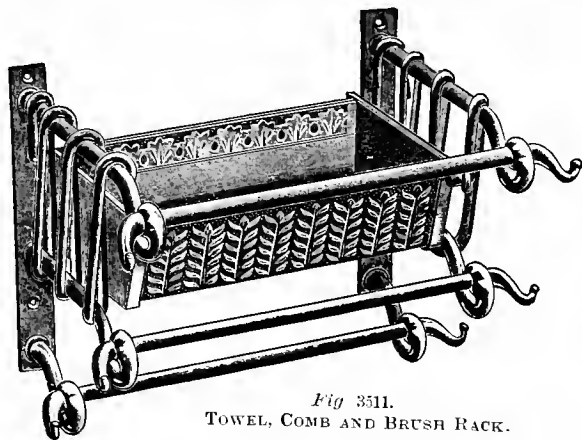

Fig. 3511.
TOWEL, COMB AND BRUSH RACK.

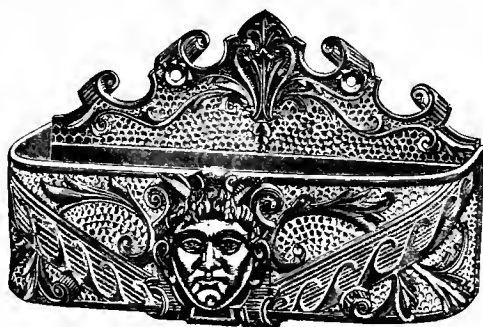

Fig. 3512. COMB AND BRUSH CASE.

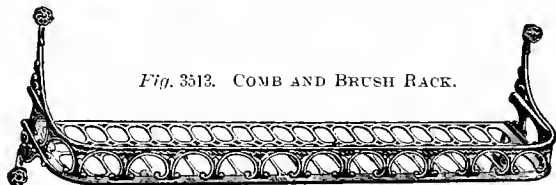

Fig. 3513. COMB AND BRUSH RACK.

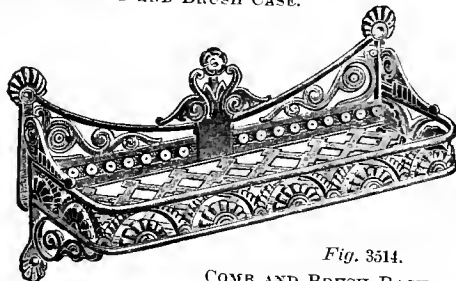

Fig. 3514.
COMB AND BRUSH RACK.



Fig. 3515. CUFF RACK.

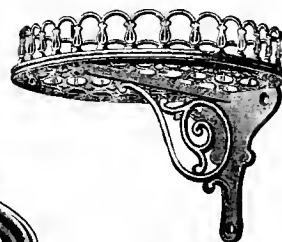
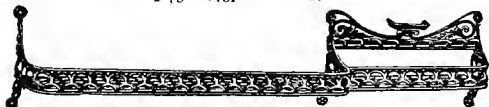

Fig. 3516.
BOTTLE BRACKET.



Figs. 3517-3518. TOWEL, COMB AND BRUSH RACK.



Fig. 3519. CUFF RACK.

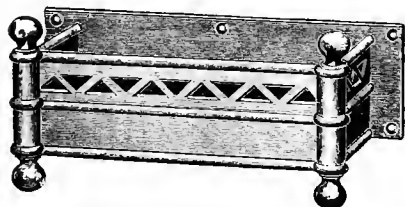

Fig. 3520. COMB AND BRUSH CASE.



Fig. 3521. TOWEL RACK.

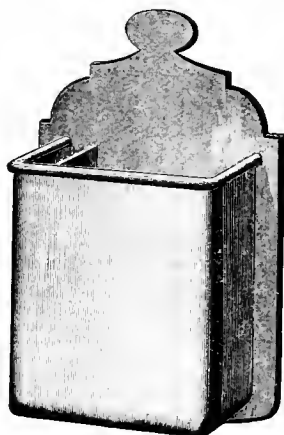

Fig. 3522. COMB AND BRUSH CASE.
Metallic.

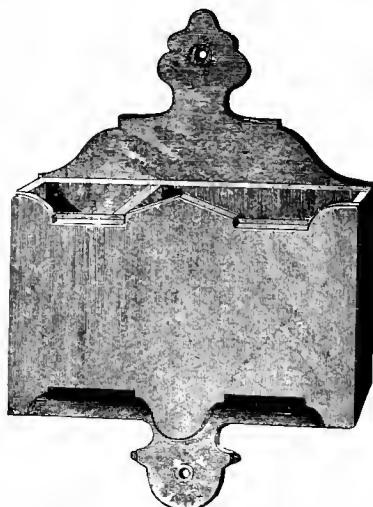

Fig. 3523. COMB AND BRUSH CASE.
Wood.



Fig. 3524. COMB AND BRUSH CASE.
Metallic, decorated.

TOILET RACKS AND CASES.

NAMES OF PARTS. Figs. 3525-3527.

- | | |
|--|---------------------------------------|
| 1. Bowl or Basin. | 9. Supply-pipe to Compression-faucet. |
| 2. Slab. | 10. Wash-basin Drain. |
| 3. Riser. | 11. Supply-pipe, Hot-water. |
| 4. Compression-faucet. | 12. Supply-pipe, Cold-water. |
| 5. Basin-valve. | 13. Tumbler-holder Drain. |
| 6. Combination Hot and Cold Water-faucets (A. & W.). | 14. Water-cooler. |
| 7. Soap-dish. | 15. Water-cooler Faucet. |

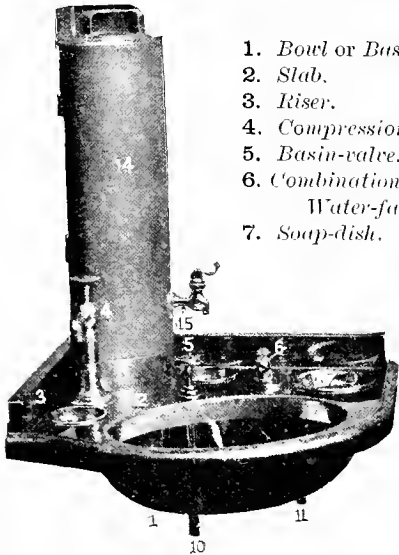

Fig. 3525.

WASH-BOWL, FITTINGS AND WATER-COOLER.

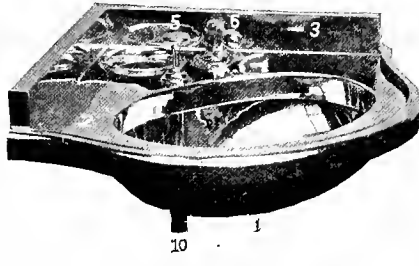

Fig. 3526.

WASH-BOWL AND FITTINGS.

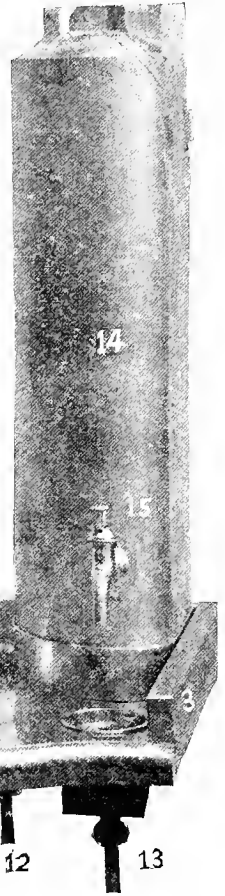

Fig. 3527. DOUBLE WASH-BOWL, FITTINGS AND WATER-COOLER.
Made of White Metal.

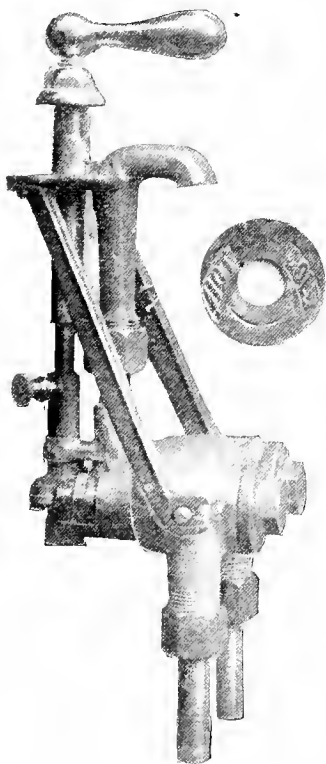

Fig. 3528.

COMBINATION HOT AND COLD
(281) WATER FAUCET.

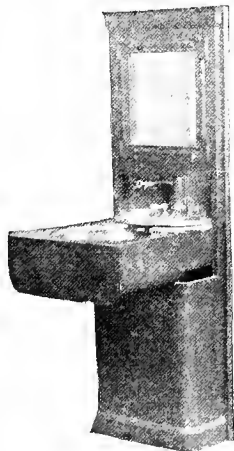

Fig. 3529.
General View.

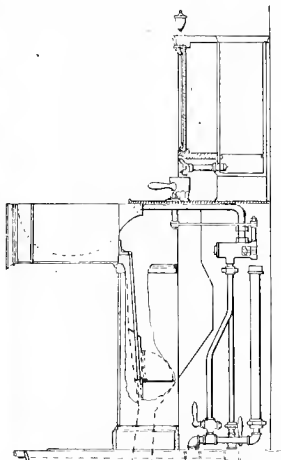

Fig. 3530.
Sectional Side Elevation.

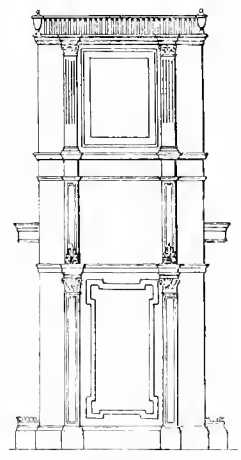

Fig. 3531.
Front Elevation.

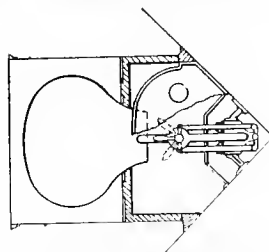

Fig. 3532. Sectional Plan.
FOLDING WASH STAND FOR
STATE-ROOMS.

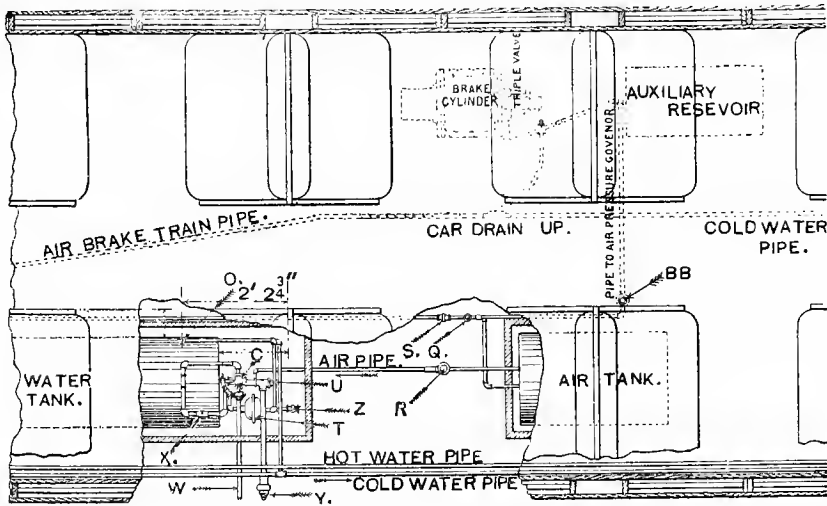

Fig. 3534. Part Sectional Plan, showing Piping and Connections between Air-tank and Water-tank.

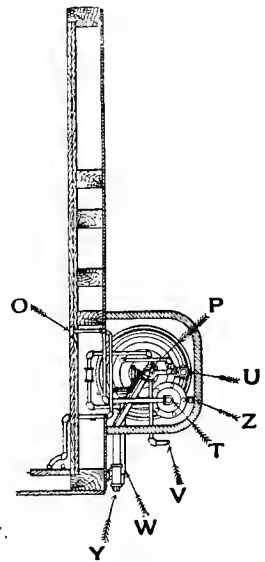

Fig. 3536. End Elevation.

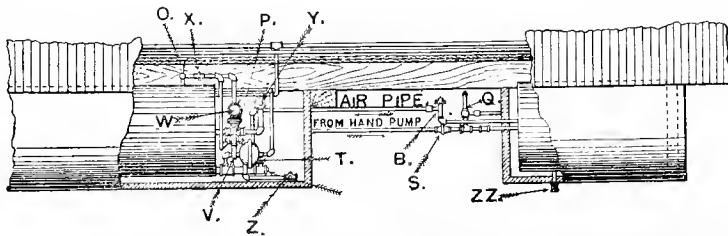

Fig. 3535. Part Sectional Elevation, showing Piping and Connections between Air-tank and Water-tank.

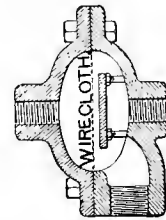

Fig. 537. Section of Water Screen.

NAMES OF PARTS OF PULLMAN WATER-SUPPLY.

Figs. 3534-3541.

- A. Shut-off Cock in Supply-pipe.
- AA. Shut-off Cock to Hand-pump.
- B. Stop and Waste-cock for Hoppers.
- BB. Air-strainer and Drip-cup.
- C. Stop-cock to Wash-bowls.
- D. Stop-cock to Faucets.
- E. Stop-cock to Fire-hose.
- G. Stop-cock to Wash-bowls.
- H. Shut-off Valve to Hot-water Coil.
- I. Check-valve in Supply-pipe.
- K. Globe-valve in Hot-water Supply-pipe.
- L. Drip Stop-cock.
- M. Safety-plug.
- N. Hot-water Boiler.
- O. Main Shut-off Cock.
- P. Three-way Valve.
- Q. Air-pressure valve or Governor.
- R. Reducing-valve.
- S. Check-valve in Hand-pump Pipe.
- T. Water Strainer or Screen.
- U. Waste-pipe and Valve.
- V. Air-vent from Water-tank.
- W. Stem of Valve P.
- X. Check-valve in Air-pressure Pipe.
- Y. Tank-filler.
- ZZ. Drip-cock in Air-tank.
- Z. Blow-off Valve, to cleanse Strainer T.

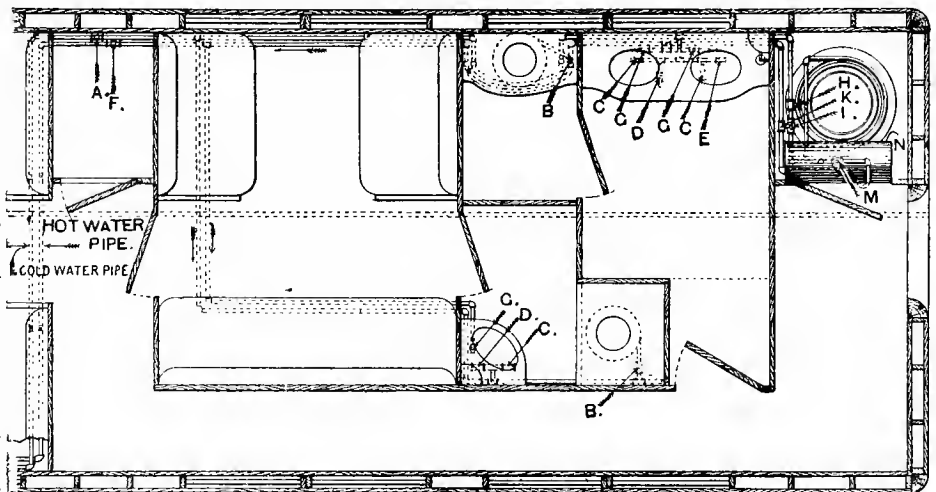

Fig. 3538. Part Sectional Plan, showing Piping and Connection between Air-tank, Heater, Storage Tank and Lavatories.

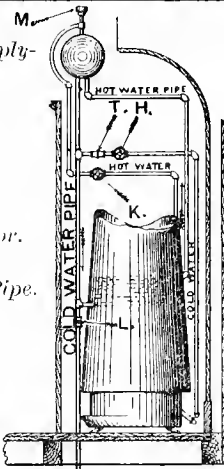

Fig. 3539. Sectional View of Heater and Piping.

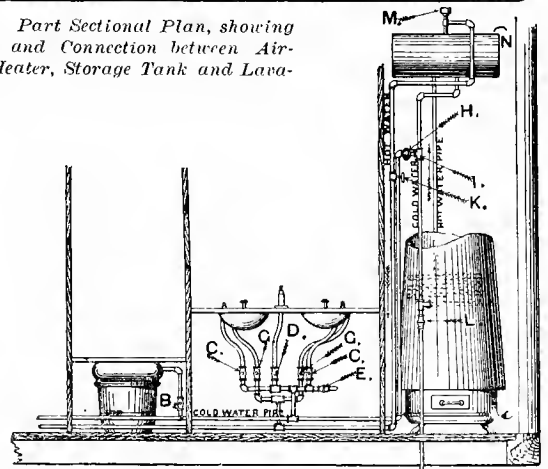
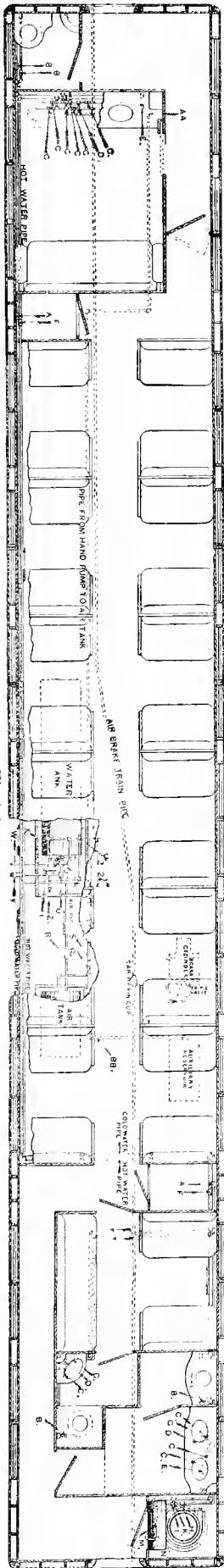

Fig. 3540. Sectional Elevation of Piping and Connections between Heater, Lavatory and Closet.

PULLMAN SYSTEM OF WATER SUPPLY FOR LAVATORIES AND CLOSETS.

Hot and Cold Waters are under Pressure of Compressed Air.



PULLMAN SYSTEM OF WATER SUPPLY FOR LAVATORIES AND CLOSETS.
 Hot and Cold Waters are Under Pressure of Compressed Air.
 Fig. 3541.

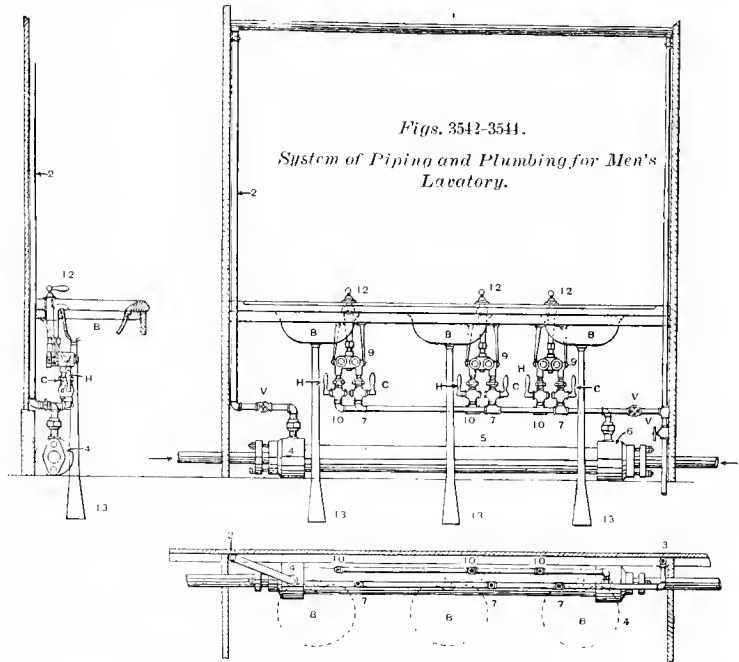

NAMES OF PARTS, Figs. 3542-3547.

- | | |
|-----------------------------------|------------------------------|
| 1. Reservoir. | 10. Hot-water Connections. |
| 2. Feed Water-pipe for Hot Water. | 12. Hot and Cold-water Cock. |
| 3. Feed-pipe for Cold Water. | 13. Bowl Waste-pipe. |
| 4. Hot-water Jacket, Ends. | B. Bowl. |
| 5. Hot-water Jacket. | C. Cold-water Connections. |
| 6. Hot-water Pipe. | H. Hot-water Connections. |
| 7. Cold-water Connections. | V. Stop-cocks. |
| 9. Water-cush Bracket. | |

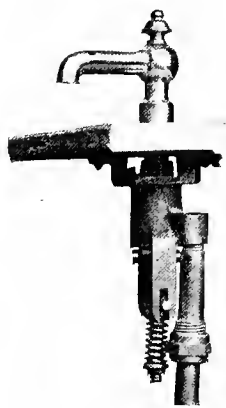
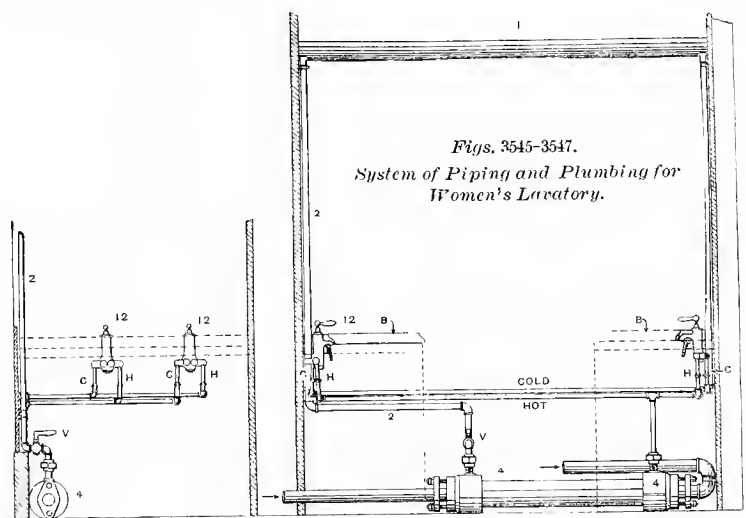
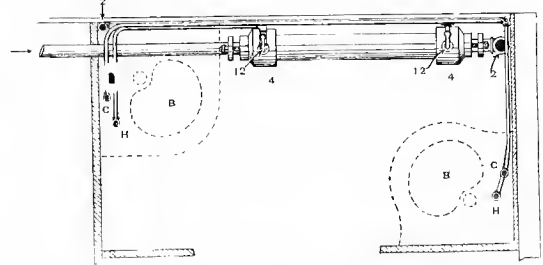

Fig. 3548.
SWING-NOZZLE FAUCET.



PULLMAN'S SYSTEM OF WATER SUPPLY FOR LAVATORIES AND CLOSETS.

Hot and Cold Waters are Under Pressure of Compressed Air.

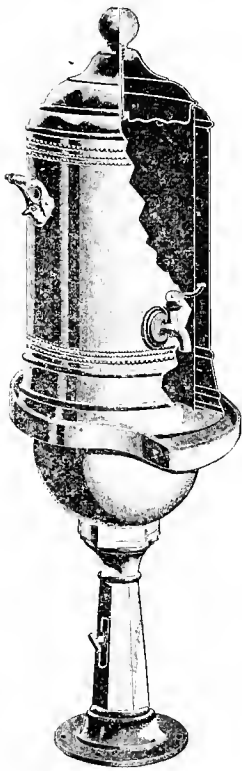
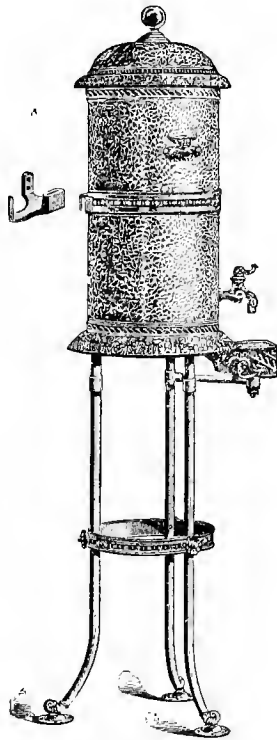

Fig. 3549.



Figs. 3550-3551.
WATER-COOLERS AND STANDS.

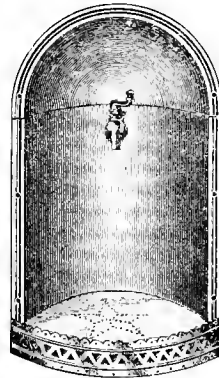

Fig. 3552.

WATER-ALCOVE .

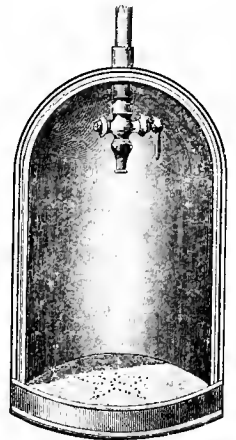

Fig. 3553.

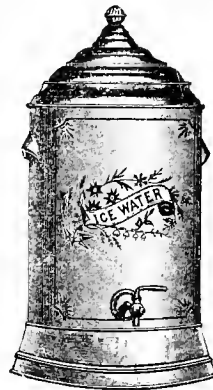

Fig. 3554.
WATER COOLER.



Fig. 3555.
WATER-COOLER EAR.



Figs. 3556-3557.
COOLER TOP AND BREAST.

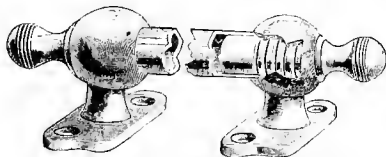

Fig. 3558. TOWEL-RODS AND BRACKET.

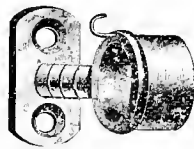

Fig. 3559. CURTAIN-ROD BRACKET.

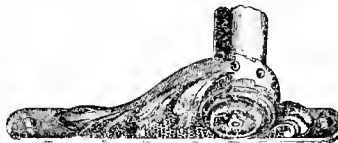

Fig. 3560. CURTAIN-ROD BRACKET.



Fig. 3561. TOWEL-ROD BRACKET.

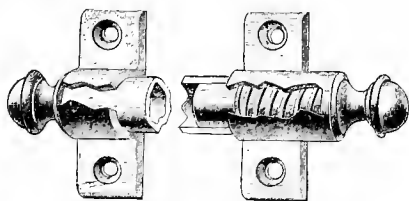

Fig. 3562. TOWEL-ROD BRACKET.

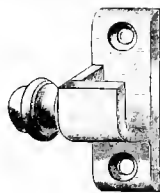

Fig. 3563.
TOWEL-ROD BRACKET.

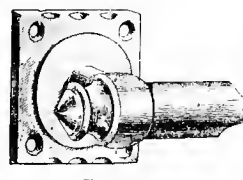

Fig. 3564.

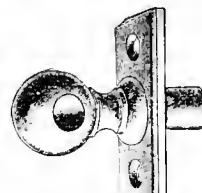

Fig. 3565.
CURTAIN-ROD BRACKETS.



Fig. 3566.

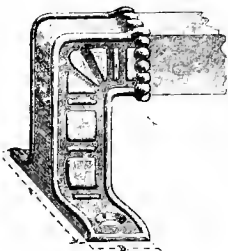

Fig. 3567.

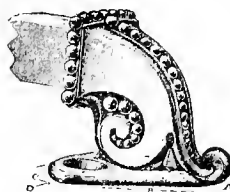

Fig. 3568.

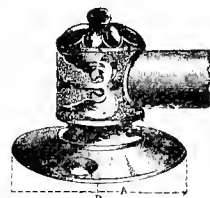

Fig. 3569.

TOWEL-ROD BRACKETS.



Fig. 3570.



Fig. 3571.

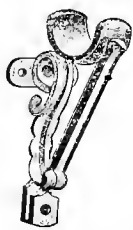

Fig. 3572.



Fig. 3573.

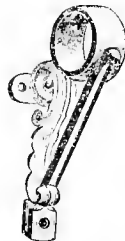

Fig. 3574.

TOWEL-ROLLER BRACKETS.



Fig. 3575.



Fig. 3576. TOWEL-ROD BRACKETS.

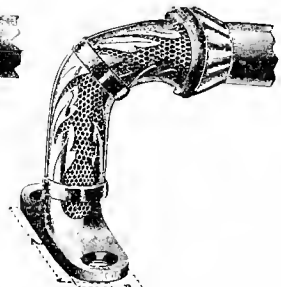

Fig. 3577.

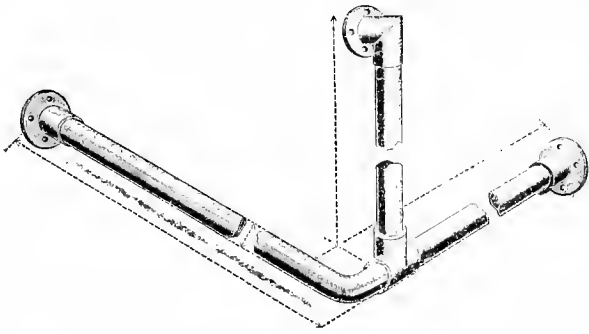
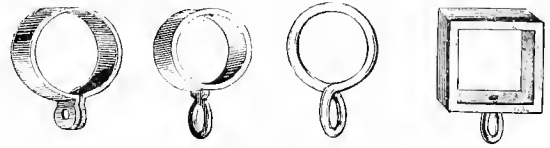

Fig. 3578.
SECTION CURTAIN-ROD.



Figs. 3579-3582.
CURTAIN RINGS.



Figs. 3583-3585.
CURTAIN-ROD BUSHINGS.

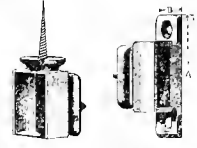

Figs. 3586-3587.
CURTAIN-ROD BRACKETS.

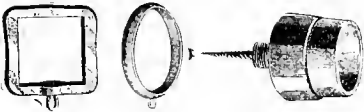

Figs. 3588-3589.
CURTAIN-RINGS.

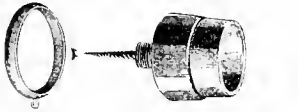
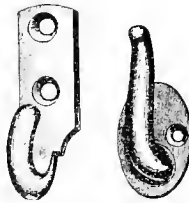

Fig. 3590.
CURTAIN-ROD BRACKET.



Figs. 3591-3592.
TOWEL-RODS.



Figs. 3593-3597. CURTAIN-CORD HOOKS.



Fig. 3598. CUP-HOOK.



Fig. 3599.



Fig. 3600.
TOWEL RACKS AND RODS.



Figs. 3601-3602.

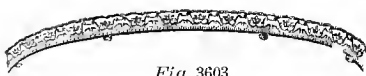
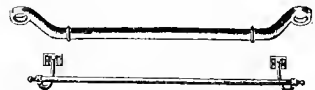

Fig. 3603.



Fig. 3604.



Figs. 3605-3606.
TOWEL-RODS.

RAILINGS FOR TOILET RACKS.

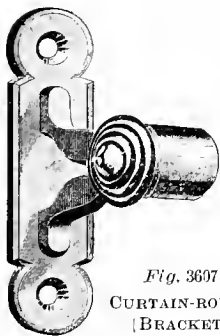

Fig. 3607.
CURTAIN-ROLLER
BRACKET.

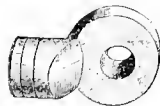
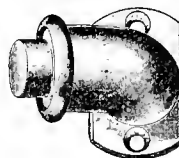

Fig. 3608.
WINDOW-GUARD
ROD BRACKET.



Fig. 3609.
CURTAIN-ROD BRACKET.



Figs. 3610-3612. CURTAIN-ROD BRACKETS.

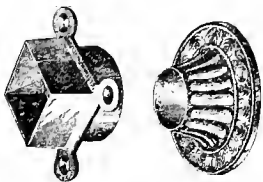
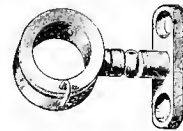

Figs. 3613-3614. CURTAIN-ROD
BUSHINGS.



Fig. 3615. CURTAIN-ROD BRACKET.

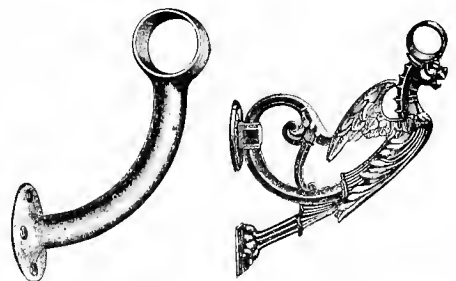

Figs. 3616-3617. FOOT-REST-ROD BRACKETS.

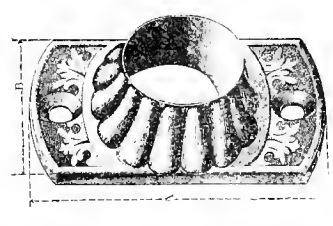
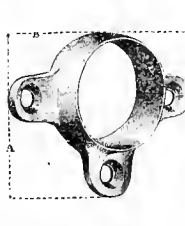
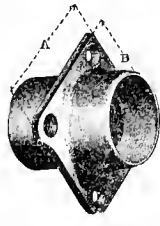

Figs. 3618-3623. CURTAIN-ROD BUSHINGS.

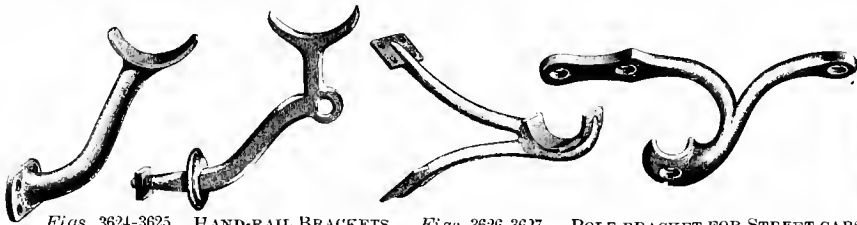

Figs. 3624-3625. HAND-RAIL BRACKETS Figs. 3626-3627. POLE-BRACKET FOR STREET-CARS.

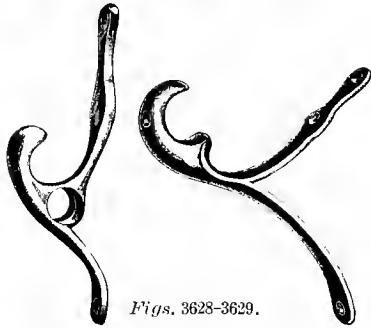

Figs. 3628-3629.

POLE-BRACKET FOR STREET-CARS.

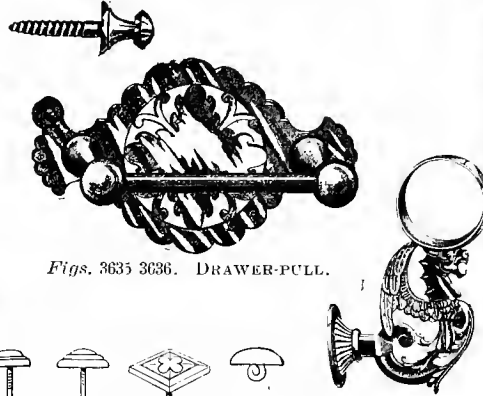

Figs. 3635-3636. DRAWER-PULL.

Fig. 3634. HAND-ROD BRACKET.



Figs. 3630-3633. POLE OR HAND-STRAPS.



Figs. 3637-3646. UPHOLSTERERS' NAILS AND BUTTONS.

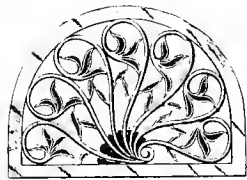

Fig. 3647.

GRILLE FOR VESTIBULE DOOR.

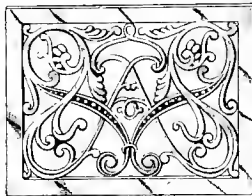

Fig. 3648.

GRILLE FOR VESTIBULE DOOR.

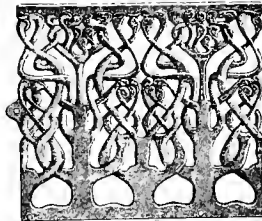

Fig. 3649.

TO COVER HEATER PIPES. ORNAMENTAL CAST WORK, GRILLES, ETC.



Fig. 3650.

FOR VESTIBULE AND KING-PIN PLATE.



Fig. 3651. FOR DOOR.

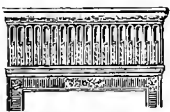

Fig. 3653. MIRROR FRAME.



Fig. 3654. TRANSOM GRILLE.



Fig. 3655. TRANSOM GRILLE. One-half.



Fig. 3656. BERTH-FRONT BORDER.



Fig. 3657. MIRROR FRAME.



Fig. 3658. MIRROR FRAME.

ORNAMENTAL CAST WORK.



Fig. 3659. BERTH CORNER.



Figs. 3660-3661. PARTITION OR WINDOW PANELS.

Panel Decorations in Relief. They are reuerced with natural wood.

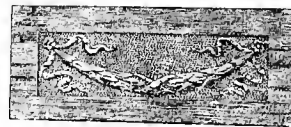
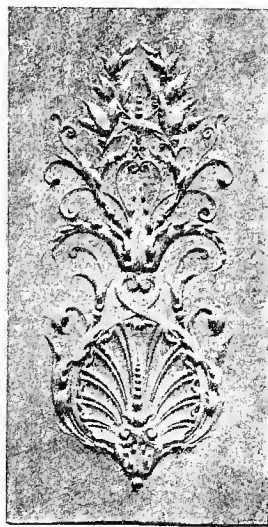

Fig. 3662. DECK WINDOW PANEL.

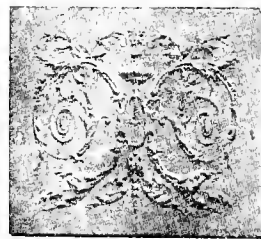
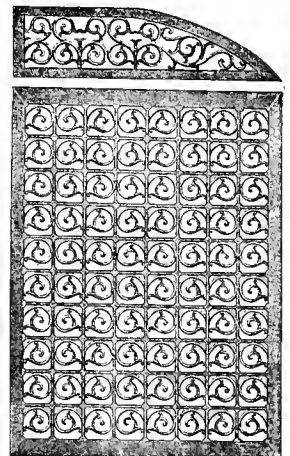
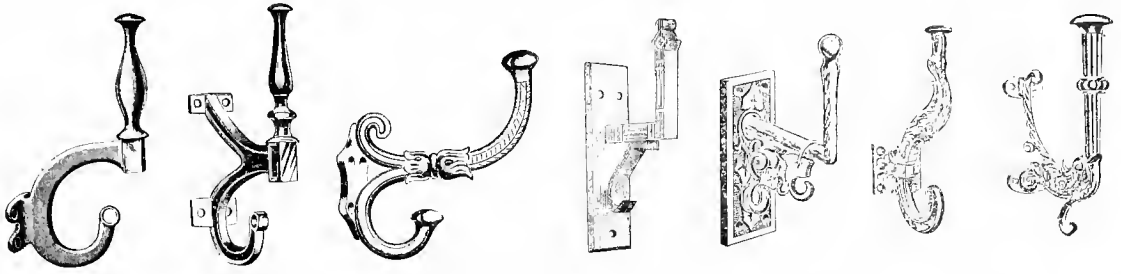

Fig. 3663. FOR BULKHEADS.



Figs. 3664-3665. CAST GRILLES.



Figs. 3666-3672. COAT AND HAT HOOKS.

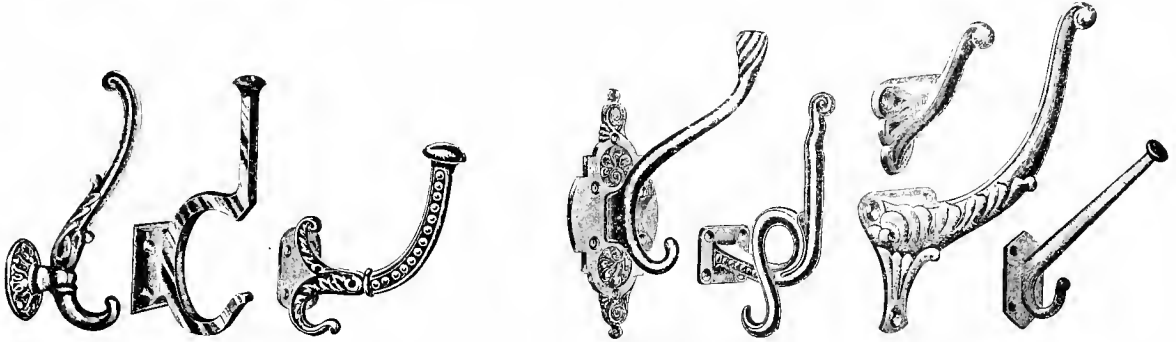

Figs. 3673-3680. COAT AND HAT HOOKS.

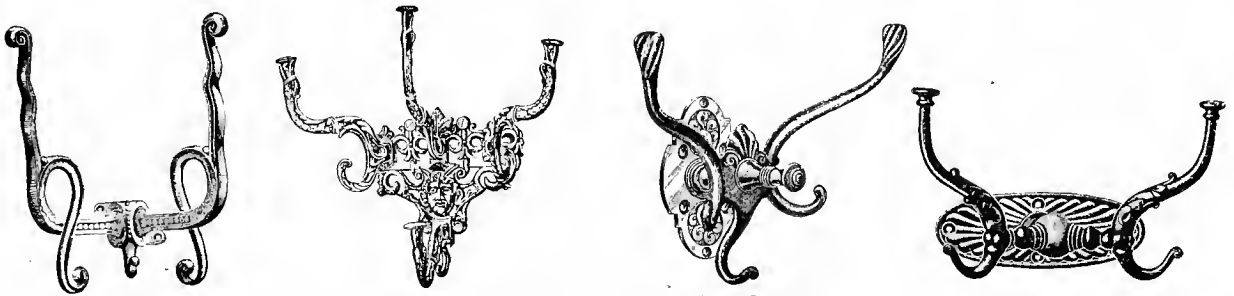

Figs. 3681-3684. COAT AND HAT HOOK CLUSTERS.

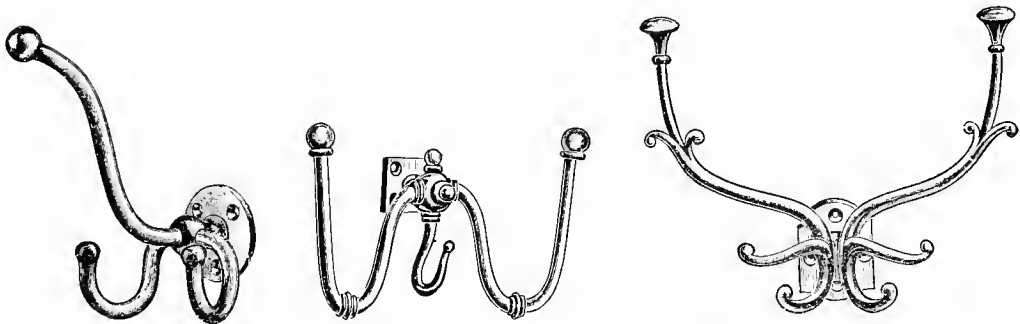

Figs. 3685-3687. COAT AND HAT HOOK CLUSTERS.

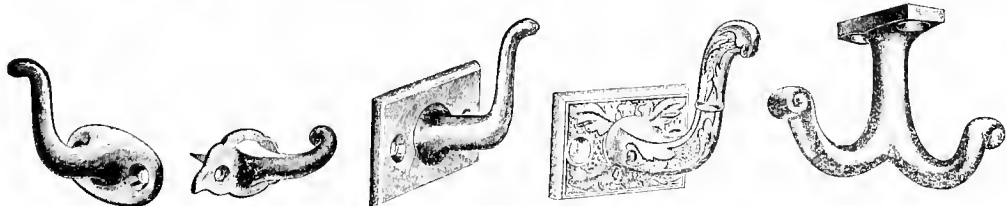

Figs. 3688-3692. COAT HOOKS.



Fig. 3693. UMBRELLA HOLDER.



Fig. 3691. UMBRELLA-HOLDER SOCKET.

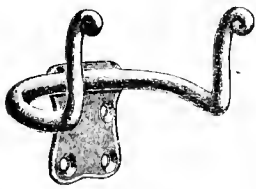

Fig. 3695.
BROOM-HOLDER OR HOOK.



Fig. 3696.
WHISK-BROOM HOLDER.

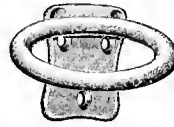

Fig. 3697.
BROOM-HOLDER.

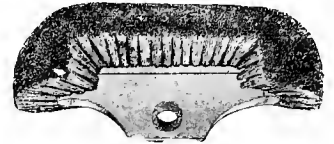

Fig. 3698.
CAR WASHER.



Fig. 3699.
BROOM IN
HOLDER.



Fig. 3700.
WHISK-BROOM AND HOLDER.



Fig. 3701.
CAR WASHER.

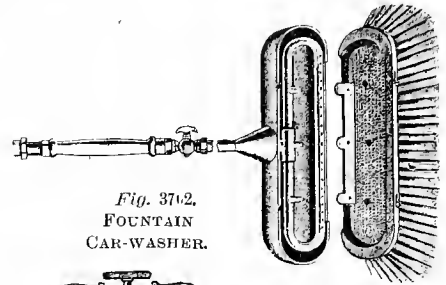

Fig. 3702.
FOUNTAIN
CAR-WASHER.



Fig. 3703. AX, POCKET AND HOLDER.



Fig. 3706.
HASSOCK.



Fig. 3707.
MATCH-STRIKER.

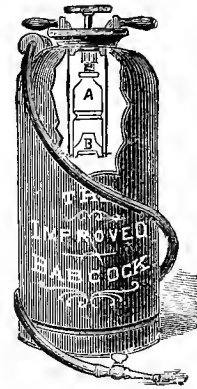

Fig. 3704.
BABCOCK FIRE-
EXTINGUISHER.
A. Acid-bottle.
B. Acid-bottle Carrier.

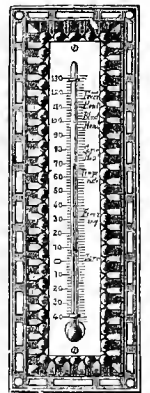

Fig. 3705.
THERMOMETER.



Fig. 3708.
MACHINE-BOLT.
Square-head.



Fig. 3709.
MACHINE-BOLT.
Hexagon-head.



Fig. 3710.
CARRIAGE-BOLT.



Fig. 3711. LAG SCREW.



Fig. 3712.
STRAP-BOLT.



Fig. 3713. U-BOLT.



Fig. 3714.
KEY-BOLT.



Fig. 3715.
EYE-BOLT.



Fig. 3716.
WASHER, OR
PLATE-WASHER.



Figs. 3717-3718.
BEVELED-WASHER.



Fig. 3719.
DOUBLE-WASHER.



Fig. 3720. JOINT-BOLT.



Fig. 3721.
TRIANGULAR-WASHER.



Fig. 3722.
SOCKET-WASHER.



Fig. 3623.
PULLEY BLOCK.



Fig. 3724. TORPEDO.



Fig. 3725.
SINGLE-SCREW TURNBUCKLE.



Fig. 3726.
RIGHT-AND-LEFT SCREW TURNBUCKLE.



Fig. 3727. SLEEVE TURNBUCKLE.

NAMES OF PARTS OF HYDRAULIC JACK. Fig. 3735.

- | | | | |
|------------------|--------------------|--------------------|-----------------------|
| 1. Head. | 10. Piston-rod. | 20. Piston-pack- | 28. Ram Packing-ring. |
| 2. Charging and | 11. Handle-strap. | ing. | 29. Ram-bonnet. |
| Air-screw. | 12. Spring-collar. | 21. Ram Valve- | 30. Cylinder-packing. |
| 3. Lowering-wire | 13. Cylinder. | seat. | 31. Cylinder Packing- |
| Screw. | 14. Piston-spring. | 22. Piston-bonnet. | ring. |
| 4. Lever. | 15. Ram. | 23. Valve-spring. | |
| 5. Arm. | 16. Sleeve. | 24. Ram or Deliv- | |
| 6. Socket. | 17. Claw or Out- | ery-valve. | |
| 7. Knuckle. | side-pipe. | 25. Bottom. | |
| 8. Lowering- | 18. Piston or Suc- | 26. Pump-plug. | |
| wire Head. | tion-valve. | 27. Ram-packing. | |
| 9. Reservoir. | 19. Claw. | | |

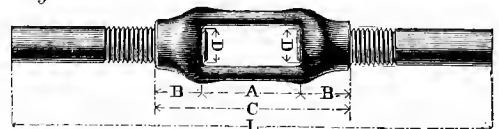

Fig. 3727a. PATENT TURNBUCKLE, R. AND L.

Numbers refer to List of Names of Parts on Opposite Page.

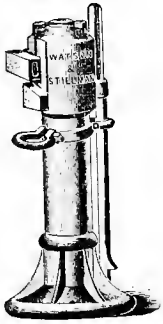

Fig. 3728. BROAD-BASE JACK.

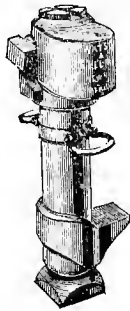

Fig. 3729. CLAW TYPE OF JACK.

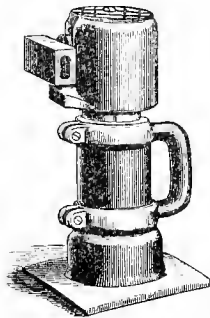

Fig. 3730. LOW JACK.

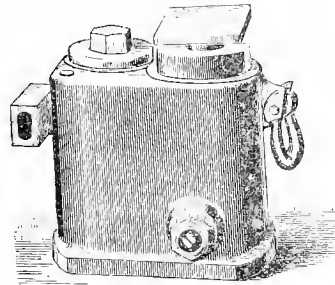

Fig. 3731. JOURNAL-BOX JACK.

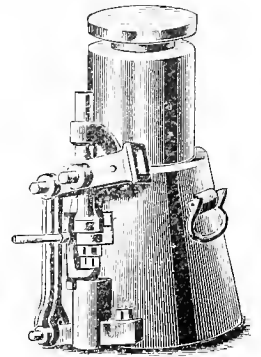

Fig. 3732. DOUBLE-PISTON OUTSIDE-PUMP JACK.



Fig. 3733. BELLBASE RATCHET SCREW-JACK.

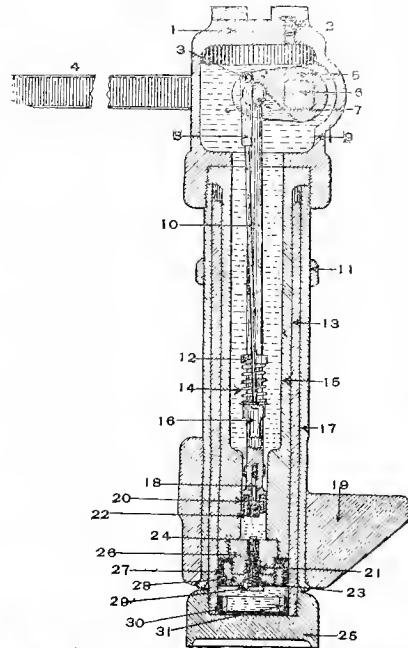

Fig. 3734. SECTIONAL VIEW OF CLAW-TYPE HYDRAULIC JACK.

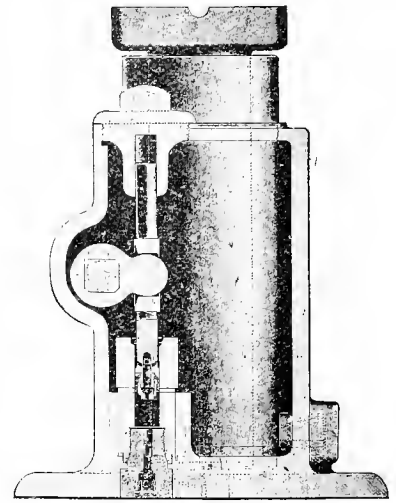
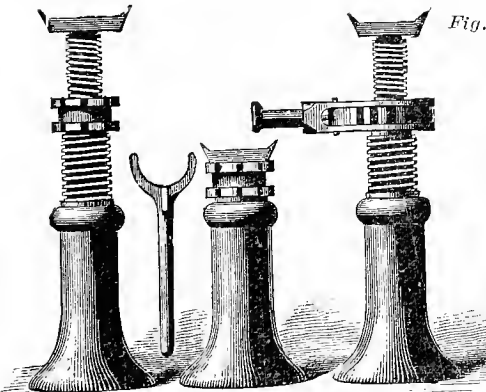
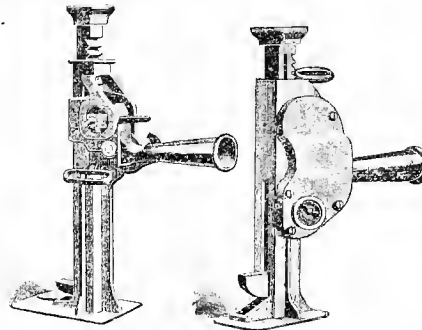

Fig. 3735. SECTIONAL VIEW OF LOW-TYPE HYDRAULIC JACK.

W. & S. HYDRAULIC JACKS.



Figs. 3736-3739. DIFFERENTIAL SCREW JACK.



Figs. 3740-3741. BARRETT'S DOUBLE-ACTING LEVER AND RACK JACKS.

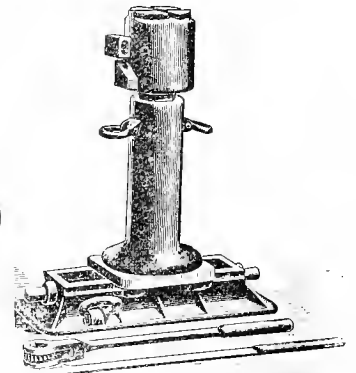

Fig. 3742. TRAVERSING HYDRAULIC JACK.



Figs. 3743-3744. CHAPMAN'S SCREW-JACK.

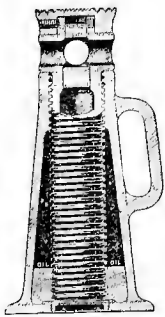

Fig. 3745. BROAD-BASE JACK.

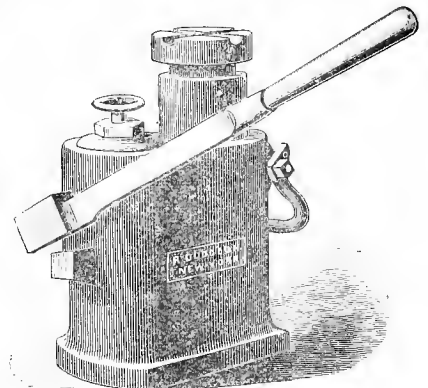
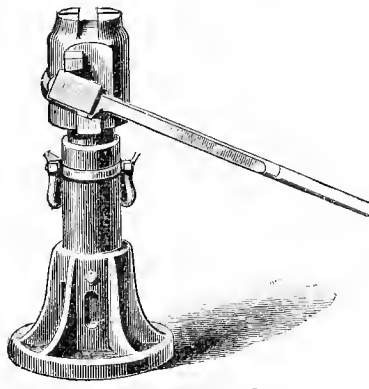

Fig. 3752. JOURNAL-BOX JACK.

DUDGEON'S HYDRAULIC JACKS.

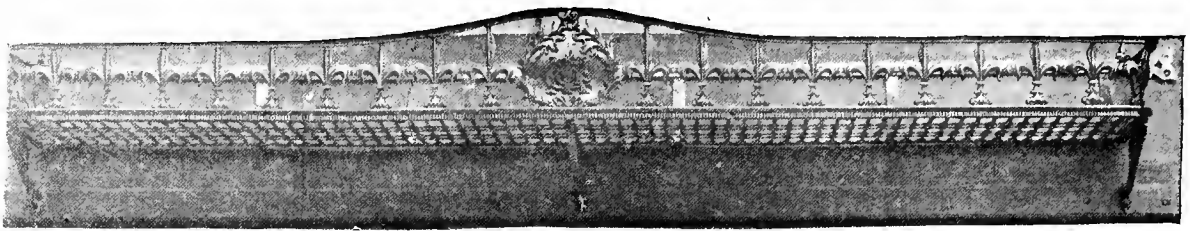

Fig. 3753. LONG CAST BASKET-RACK.

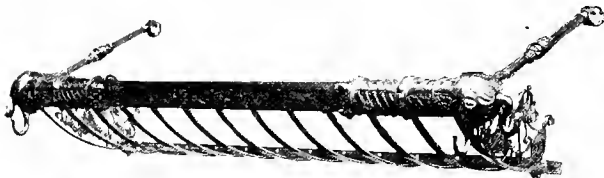

Fig. 3754.

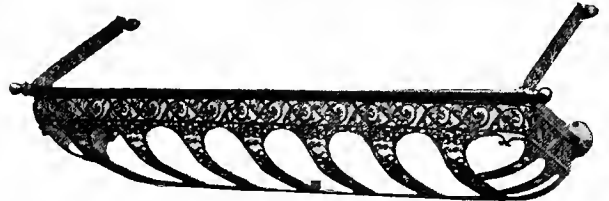

Fig. 3755.

CAST BASKET-RACKS.

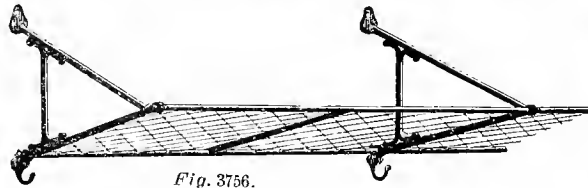

Fig. 3756.

CONTINUOUS BASKET-RACK.

Any length. Distance between brackets, 24 ins. Width, 12 ins.

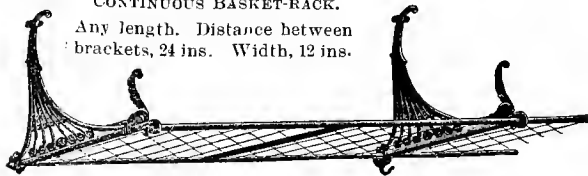

Fig. 3758. CONTINUOUS BASKET-RACK.

Any length. Distance between Brackets, 24 ins. Width, 12 ins.



Fig. 3757.

WIRE BASKET-RACK, WITH CAST-ENDS.

Any length. Depth, 3 ins. Width, 10½ ins.

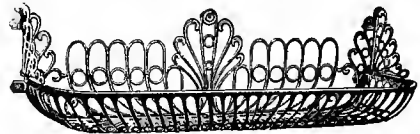

Fig. 3759. CAST BASKET-RACK.

Length, 24-30 ins. Depth, 8 ins. Width, 8 ins.

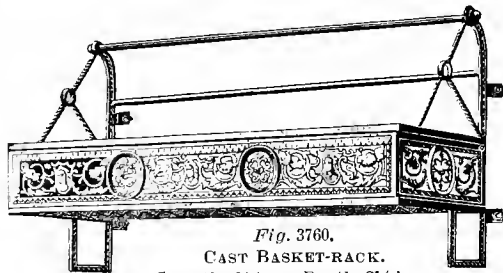

Fig. 3760.

CAST BASKET-RACK.

Length, 24 ins. Depth, 3¼ ins. Width, 8 ins.

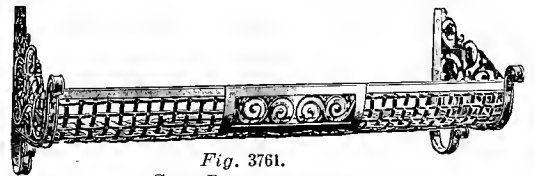

Fig. 3761.

CAST BASKET-RACK.

Any length. Depth, 3½ ins. Width, 8¼ ins.

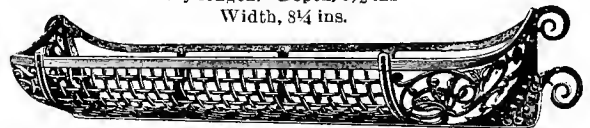

Fig. 3763.

CAST BASKET-RACK.

Length, 36 ins. Depth, 3 ins. Width, 8¼ ins.

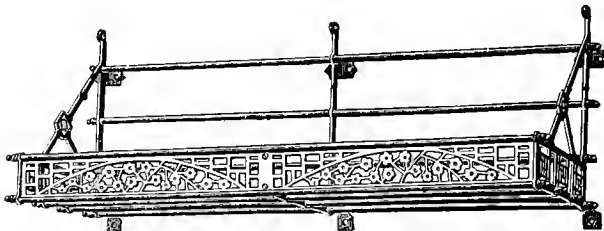

Fig. 3762. CAST BASKET-RACK.

Any length. Depth, 1¾ ins. Width, 6½ ins.

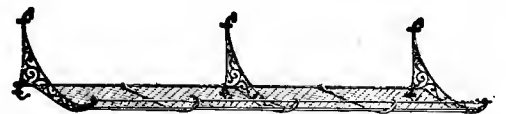

Fig. 3764. WIRE BASKET-RACK, WITH CAST BRACKETS.

Any length. Distance between Brackets, 24 ins. Width, 8 ins.

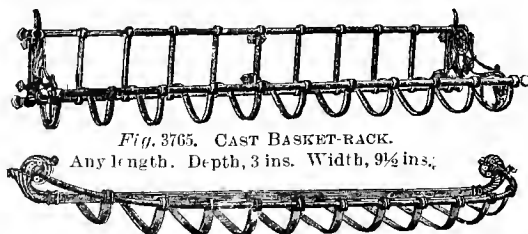
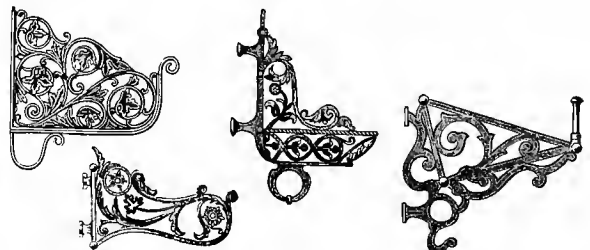

Fig. 3765. CAST BASKET-RACK.

Any length. Depth, 3 ins. Width, 9¼ ins.



Figs. 3767-3770. CAST BRACKET-ENDS FOR BASKET-RACKS.

Fig. 3766. CAST BASKET-RACK.
Length, 35-40 ins. Depth, 3 ins. Width, 8½ ins.

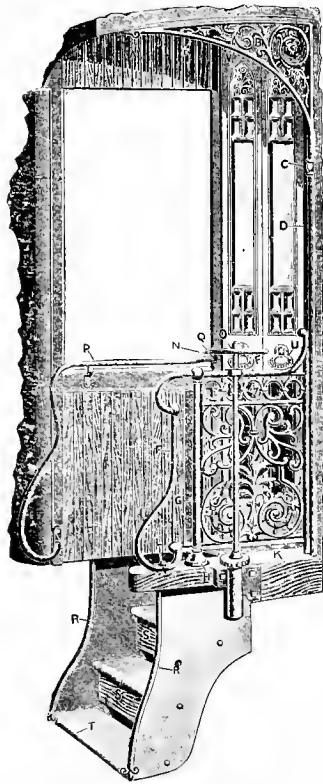

Fig. 3771. Sectional View.
VESTIBULED PLATFORM AND
ITS TRIMMINGS.

NAMES OF PARTS. Fig. 3772.

- | | |
|------------------------|------------------------|
| A. Ornamental Casting. | H. Body Grab-rail. |
| B. Ornamental Casting. | I. Brake-wheel. |
| C. Hand-rail Nut. | J. Connecting-strip. |
| D. Flush Handle. | K. Door-frame. |
| E. Brake-staff Holder. | L. Ornamental Casting. |
| F. Step-fender. | M. Door-frame. |
| G. Platform End-rail. | |

NAMES OF PARTS. Fig. 3771.

- | | |
|------------------------|------------------------|
| A. Connecting strip | L. Rail-bolt. |
| B. Ornamental Casting. | M. Brake-staff Holder. |
| C. Post-rail Ornament. | N. Hand-rail Nut. |
| D. Connecting-strip. | O. Hand-rail Nut. |
| E. Connecting-strip. | P. Body Grab-rail. |
| F. Grab-rail. | Q. Grab-rail Bushing. |
| G. Post. | R. Step-fender. |
| H. Rail-base. | S. Step-molding. |
| I. Rail-panel. | T. Step-molding. |
| J. Rail-post Strip. | U. Door Drop-handle. |
| K. Bottom-rail. | V. Ornamental Casting. |



Figs. 3773-3774.
WINDOW GUARD-RODS.

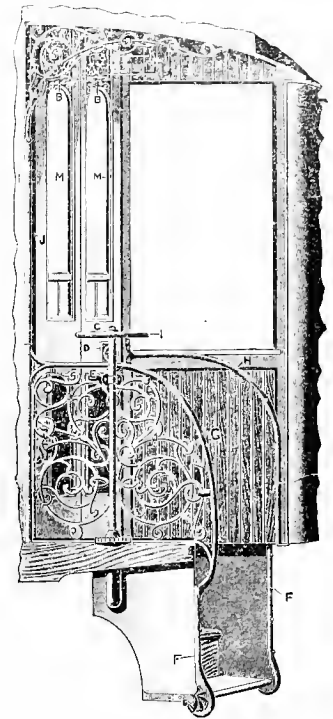
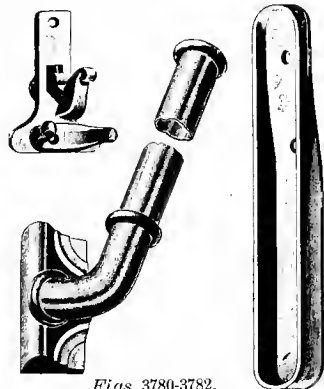

Fig. 3772. Sectional View.
VESTIBULED PLATFORM, AND
ITS TRIMMINGS.



Figs. 3780-3782.
DOOR-GUARD DROP-ROD CATCH AND
POCKET.

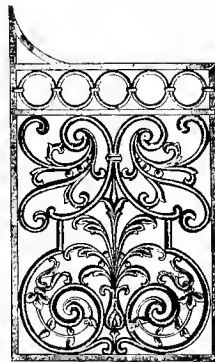
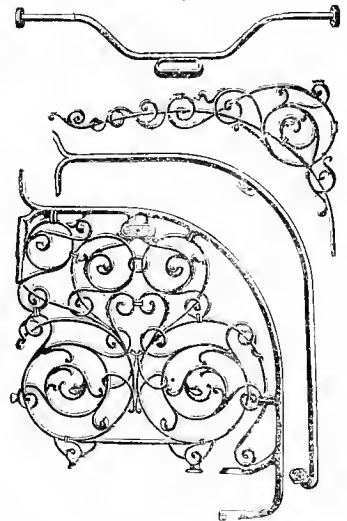

Fig. 3775.
PLATFORM-GATE PANEL.

Fig. 3776. PLATFORM BRACK.



Figs. 3777-3779.
PLATFORM-END HAND-RAILS, PANEL
AND BRACKET.



Fig. 3783.
PLATFORM SWING-BAR.

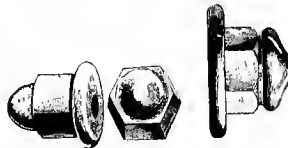

Figs. 3784-3786.
PLATFORM HAND-RAIL NUTS.

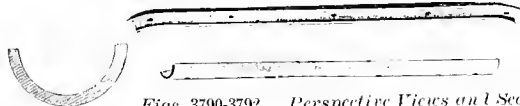

Figs. 3790-3792. Perspective Views and Section.
METALLIC STEP MOLDINGS OR NOSINGS.



Figs. 3785-3789.
STEP-FACINGS,
Right and Left.

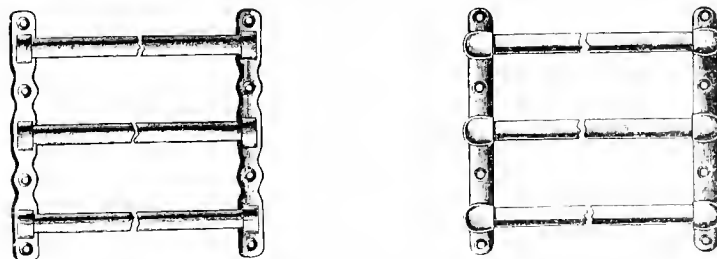

Fig. 3787. WINDOW-GUARD BRACKETS AND RODS. Fig. 3793.

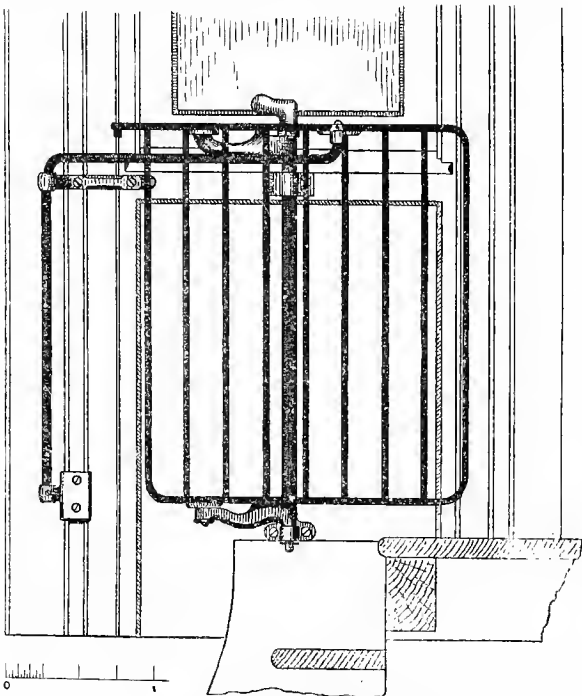

Fig. 3794. Elevation of Open Gate.
WOOD'S PLATFORM GATE.

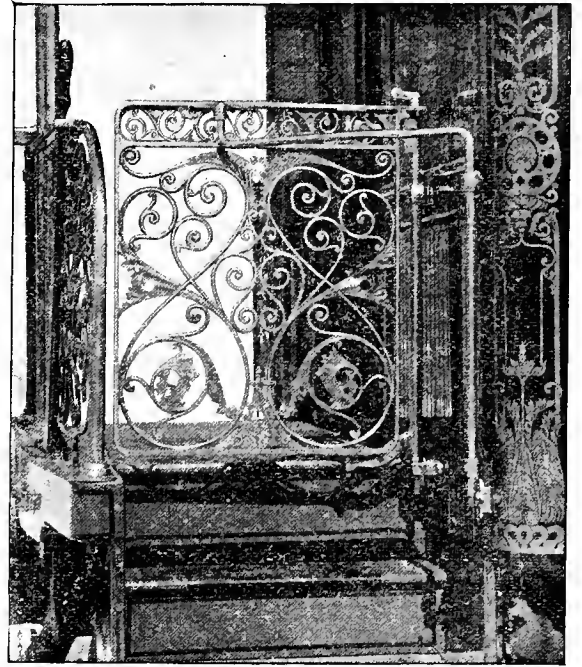

Fig. 3795. Perspective View.
WOOD'S PLATFORM GATE, DECORATED.

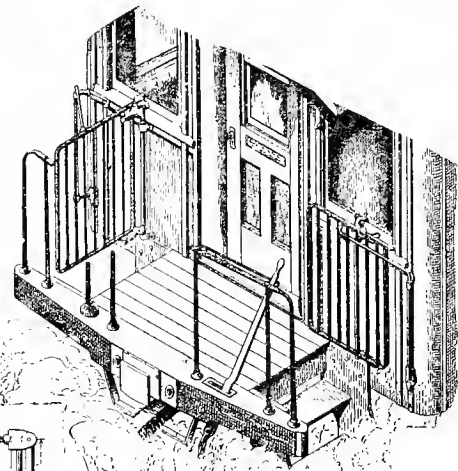
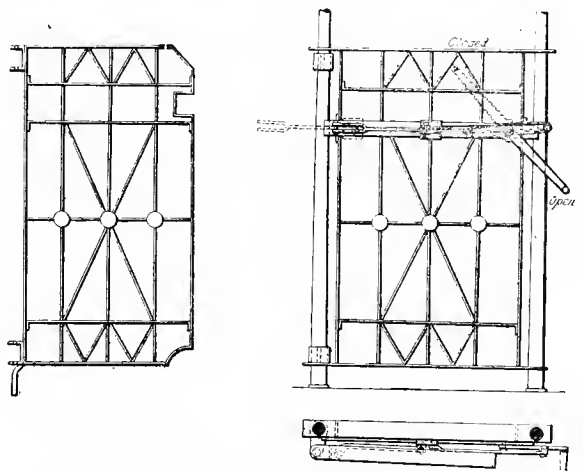

Fig. 3796. Perspective View.
WOOD'S PLATFORM GATE.



Figs. 3797-3800. Plan and Elevations.
GOLD'S PLATFORM GATE.

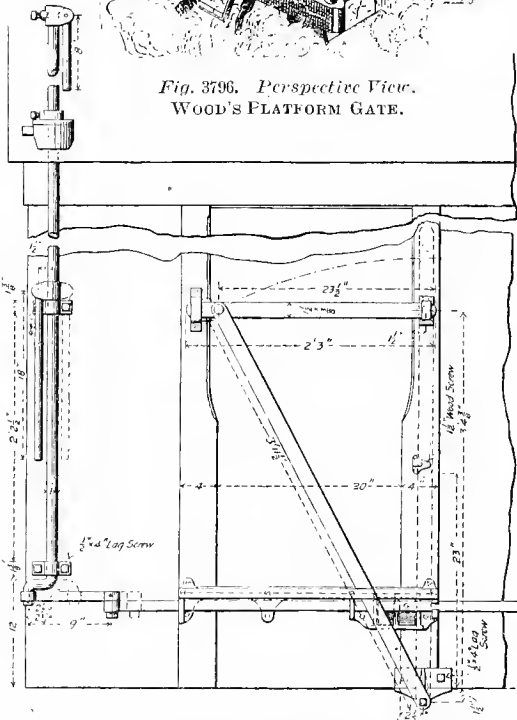
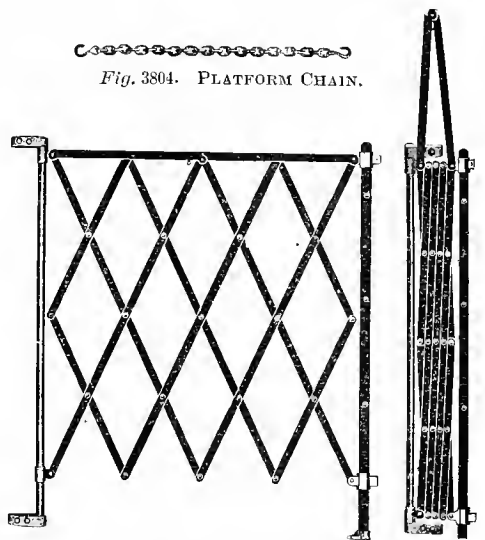

Fig. 3801-3803. Elevations and Plan.

GATE FOR SPECIAL SUBURBAN CARS, ILLINOIS CENTRAL RAILROAD.

Fig. 3804. PLATFORM CHAIN.



Figs. 3805-3806. Open, Closed.
FOLDING PLATFORM TAIL-GATE.

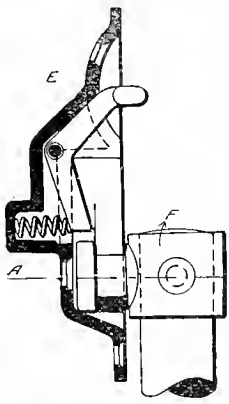

Fig. 3897. Section at Center.

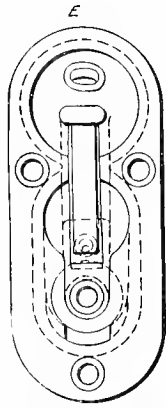
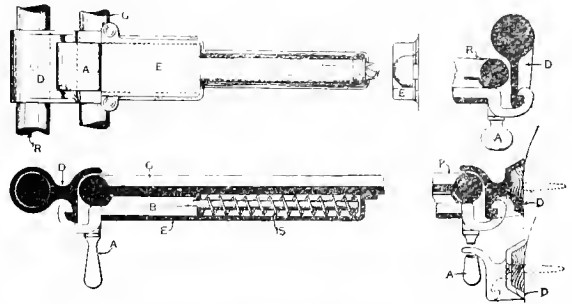

Fig. 3898. Back View.



Figs. 3810-3813. LATCH FOR PLATFORM GATES OF PULLMAN OBSERVATION CARS.

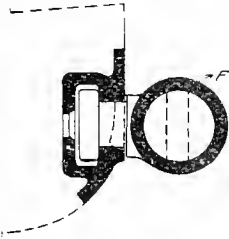

Fig. 3800. Plan. CATCH FOR PULLMAN VESTIBULE GATE.

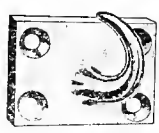

Fig. 3814. MAIL-BAG HOOK.



Fig. 3815. LETTER-CASE LABEL-HOLDER.



Fig. 3816. SAFETY ROD BRACKET.

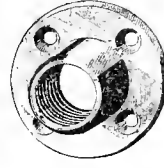

Fig. 3817. BUSHING.

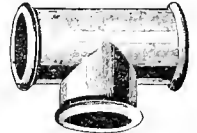

Fig. 3818. 'T' JOINT.



Fig. 3820. LETTER-BOX LID.



Fig. 3821. GRAB HANDLE.

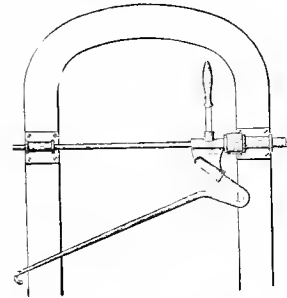
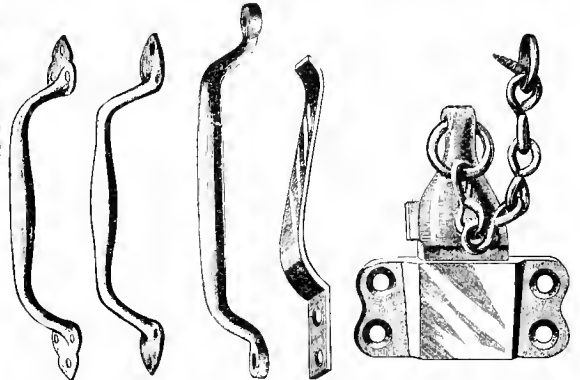

Fig. 3819. MAIL-BAG CATCHER.



Fig. 3822. LETTER-BOX LID.



Figs. 3823-3825. DOOR-HANDLES.

Fig. 3826. LETTER-CASE DOOR-WEDGE AND LABEL-HOLDER.

Fig. 3827. CLASP.

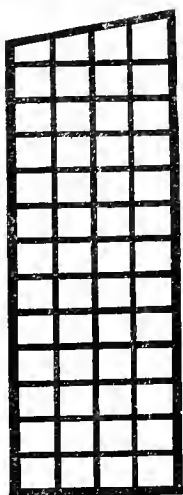
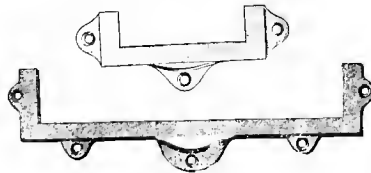

Fig. 3832. PAPER-CASE CASTING.



Fig. 3828. LABEL-HOLDER.



Figs. 3829-3830. PAPER-CASE LABEL-HOLDERS.



Fig. 3831. PAPER-CASE LABEL-HOLDER.

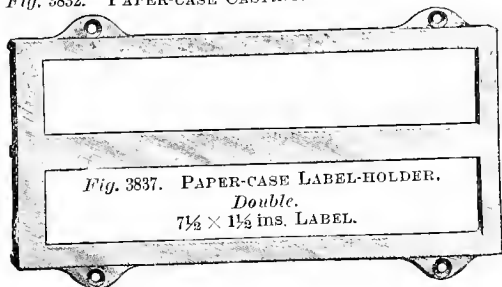

Fig. 3837. PAPER-CASE LABEL-HOLDER. Double. 7 1/2 x 1 1/2 ins. LABEL.



Fig. 3833.



Fig. 3834.



Fig. 3835.



Fig. 3836.

POUCH HOOKS WITH SQUARE AND ROUND EYES.

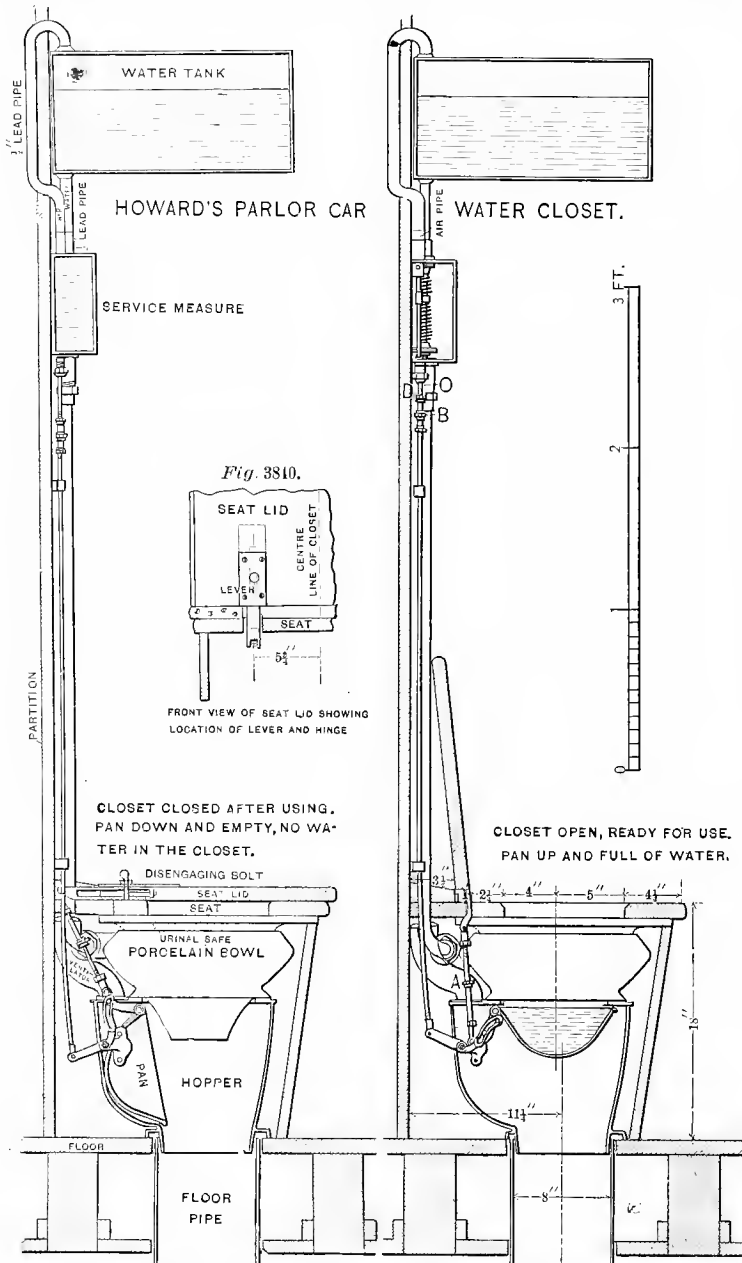

Fig. 3838. Seat Closed.

Fig. 3839. Seat Open.

Sectional Views.

WATER-CLOSET FOR COACHES AND PALACE CARS.

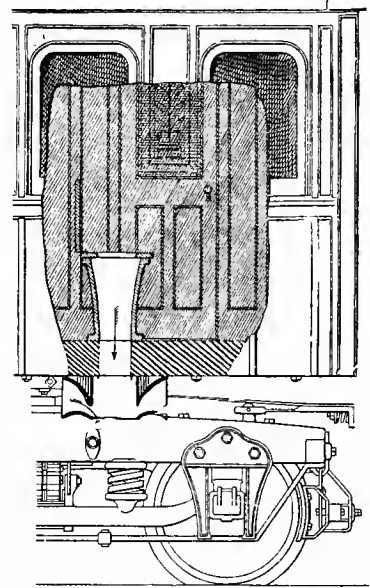

Fig. 3841.

Section through Closet-hopper.
BELL'S EXHAUST HOPPER-VENTILATOR.

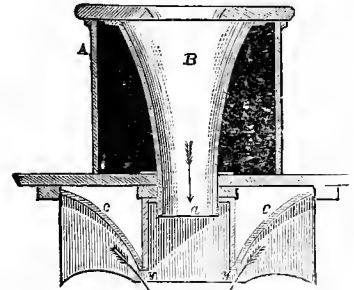
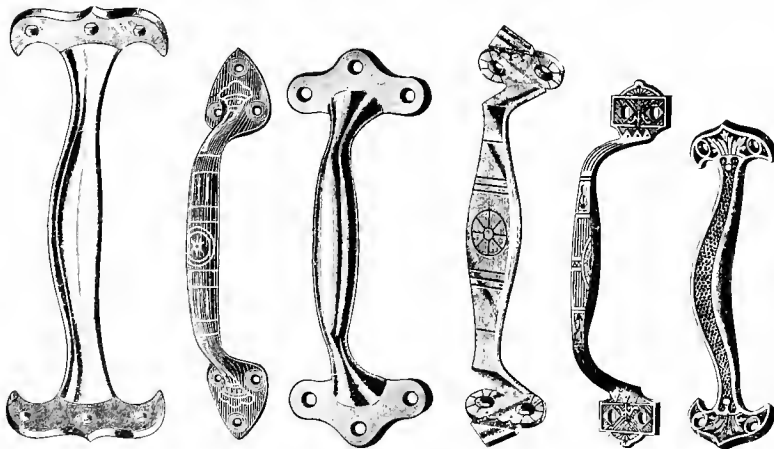

Fig. 3842. Enlarged Section.

BELL'S EXHAUST HOPPER-VENTILATOR.
A. Closet-hopper B. Closet-hopper.
Casing. y. Throat, of Ven-
C. Cone. tilator.



Figs. 3844-3849.

SALOON HANDLES.

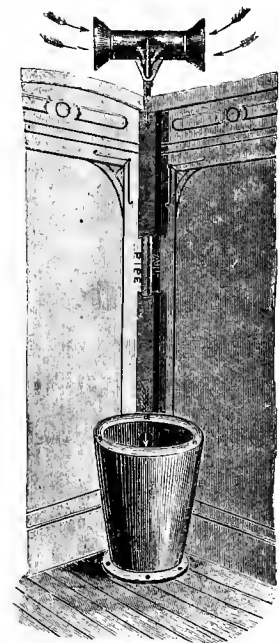
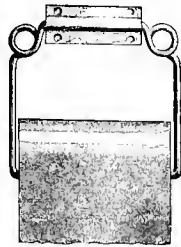
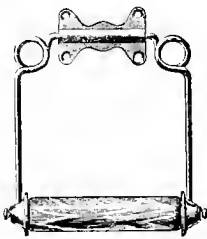

Fig. 3843.

CLOSET-HOPPER AND WIND-SCOOP.



Figs. 3850-3851.

PAPER HOLDERS AND ROLL.

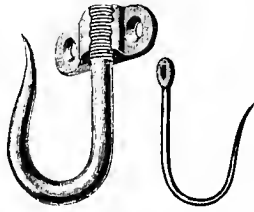

Figs. 3852-3853.

PAPER-HOOKS.



Fig. 3871. PLAIN CORNER-URINAL.

Figs. 3855-3856.

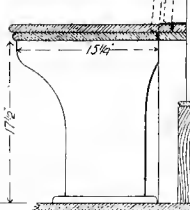
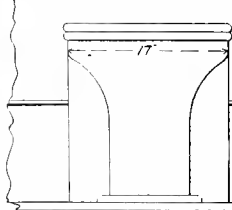
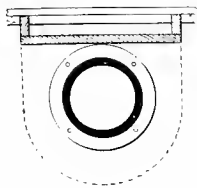
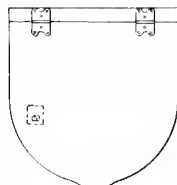
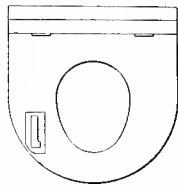

Figs. 3857-3859. THE "STANDARD" DRY-CLOSET HOPPER AND SEAT. HENRY C. HART MANUFACTURING COMPANY.

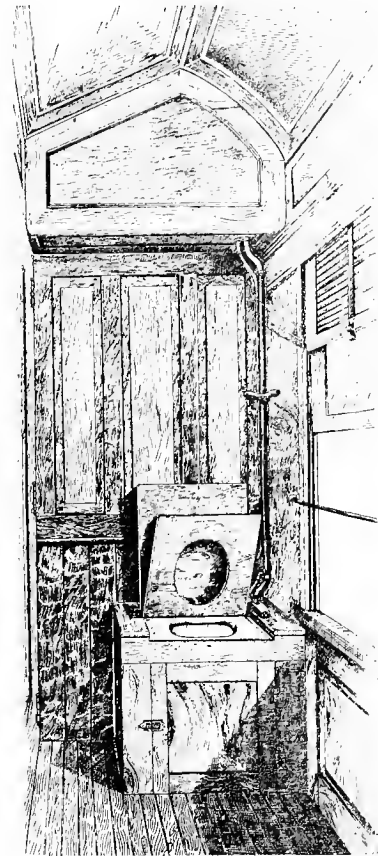

Fig. 3854. WATER-CLOSET HOPPER SEAT AND TANK. H. C. HART MFG. CO.

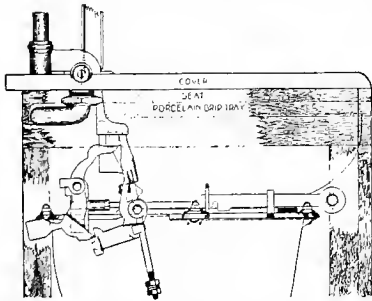
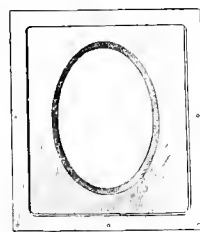

Fig. 3863. CROSS SECTION OF HOPPER, SHOWING DUMPING DEVICE OF FIG. 3854. When cover is raised the seat accompanies it.



Fig. 3862.

OBLIQUE CLOSET-HOPPER.



ENAMELED DRIP TRAY FOR OVAL-SEAT.

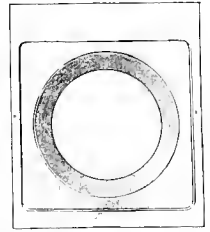

Fig. 3860-3861.

ENAMELED DRIP TRAY FOR ROUND-SEAT.



Fig. 3864. SLOPING CONE-SHAPED CLOSET-HOPPER.

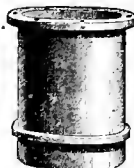

Fig. 3865. STRAIGHT EARTHEN CLOSET-HOPPER.



Fig. 3866. STRAIGHT CONE-SHAPED EARTHEN HOPPER.

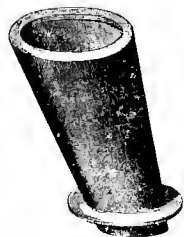

Fig. 3867. OBLIQUE CONE-SHAPED IRON HOPPER.



Fig. 3868. EARTHEN HOPPER WITH SQUARE VENT.



Fig. 3869. PORCELAIN WASH-BOWL.

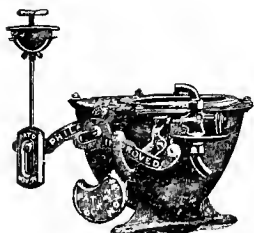

Fig. 3870. PHILADELPHIA WATER-CLOSET. (295)

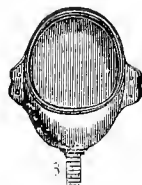

Fig. 3872. PLAIN SIDE-URINAL.

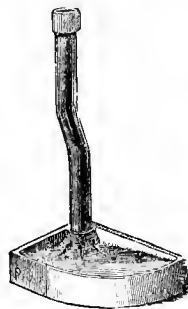

Fig. 3873. URINAL DRIP-PAN.

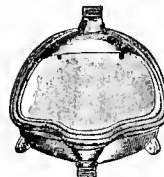

Fig. 3874. With Hood, Tabs and Lip.

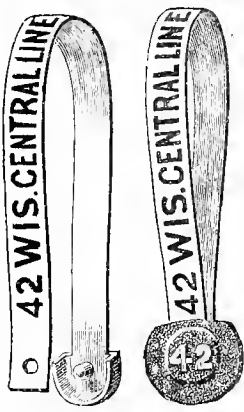

Fig. 3875. With Hood, Lip and Ventilator.



Fig. 3876. Plain Enameled Iron Urinal.

CORNER-URINALS.



Not pressed. Pressed.

Figs. 3877-3878. BROOKS'S CAST-IN HORSE-SHOE SHACKLE LEAD SEAL.



Fig. 3879. CAST IN LEAD RIVET AND TIN PRINTED SHACKLE.



Fig. 3880. SHEET METAL SHACKLE WITH LEAD SEAL.



Fig. 3881. CAST IN STAMPED TIN SHACKLE AND LEAD SEAL. Sealed and stamped.



Fig. 3882. SHEET METAL EYELET SHACKLE CAR-SEAL.



Fig. 3883. TIN SHACKLE AND LEAD RIVET-SEAL.



Fig. 3884. TIN SHACKLE AND LEAD SEAL WITH TIN RETURN-TAG.



Fig. 3885. DOUBLE EYELET PRINTED METAL-STRIP.



Fig. 3886. CENTRAL CAST-IN CROSSWISE LEAD SEAL WITH DETECTIVE WIRE.



Fig. 3887a. SAFETY CAST-IN COIL WIRE PEBBLED LEAD SEAL WITH INDENTED B WIRE.



Fig. 3888a. THE PERFECTION STAMPED ENCASED EYELET RIVET SHACKLE.



Fig. 3889a. ENCASED EYELET RIVET SHACKLE LEAD SEAL. Showing how the reverse or oblong head side of the rivet-seal is pressed.



Fig. 3890a. BROOKS'S HORSESHOE SEAL.

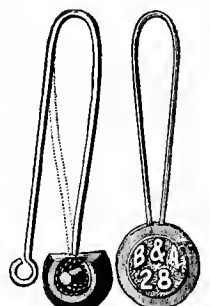

Not Pressed. Pressed.



Unpressed.



Pressed.

Fig. 3891a. BROOKS'S CODING LEAD-SEAL.

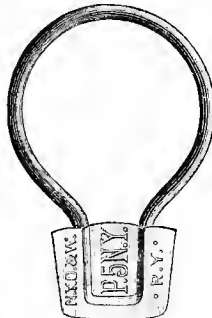

Fig. 3892a. KEYSTONE CAR-SEAL.

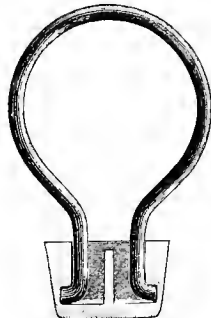

Fig. 3893. CLAY-CAR SEAL.

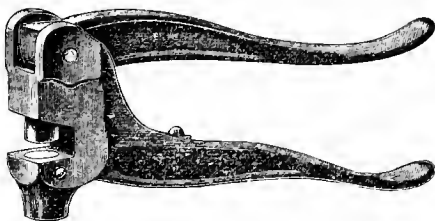

Fig. 3894. SEAL PRESS.

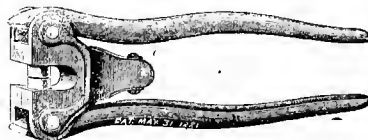
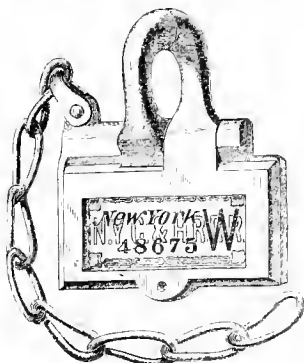

Fig. 3895. DOUBLE-LEVER SEAL-PRESS.



Fig. 3896. SMALL HAMMER SEAL-PRESS.



COMBINATION GLASS AND PAPER SEAL.

NEW YORK
6361
BUFFALO

Made in all sizes

Fig. 3897a.

BROOKS'S COMBINATION GLASS AND PAPER SEAL.

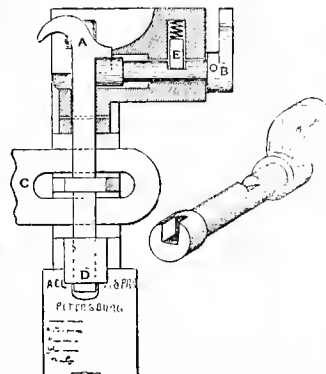

Fig. 3898a. SULLY'S SEAL-LOCK.

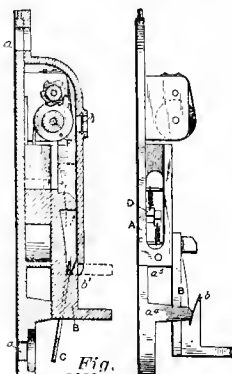

Fig. 3899a. BEASLEY'S SEAL LOCK.



Fig. 3900.

SIX-PLY WIRE SHACKLE AND LEAD CAR-SEAL. (296)



Fig. 3901.
No. 92. PLUSH SEAT WITH HIGH BACK AND HEAD-ROLL.

Fig. 3902.
No. 91. RATTAN SEAT WITH OAK ARM-REST.

Fig. 3903.
No. 93. LEATHER SEAT WITH METALLIC ARM-REST.

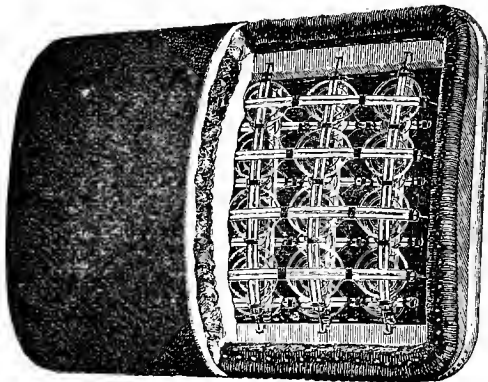

Fig. 3904. Sectional View.
UPHOLSTERED BACK-SPRINGS.

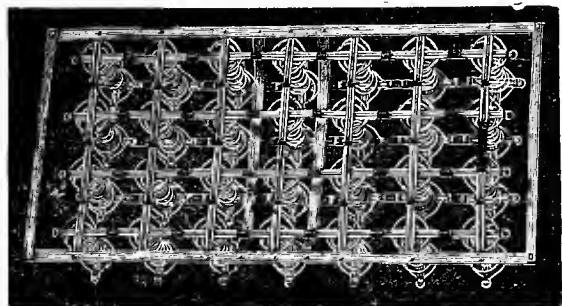

Fig. 3905. SPRING EDGE CUSHION SPRINGS.

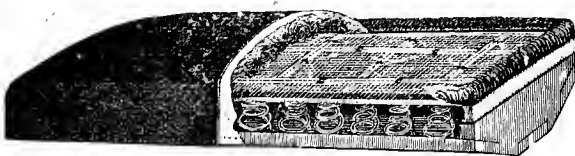

Fig. 3906. Sectional View.
UPHOLSTERED CUSHION-SPRINGS.

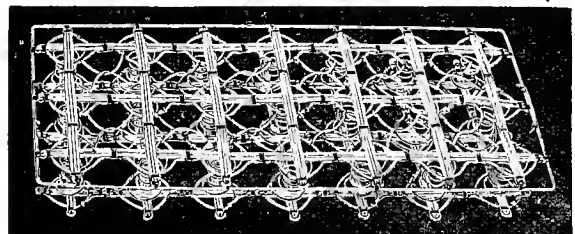

Fig. 3907.
PLAIN SPRINGS FOR CUSHION.

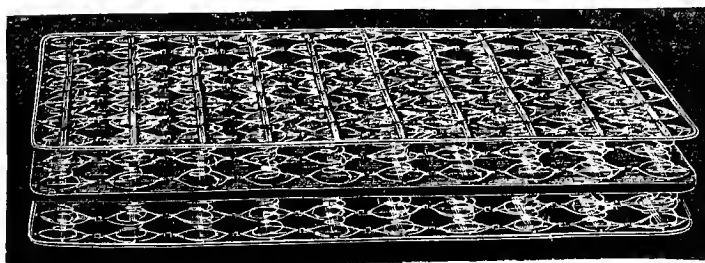
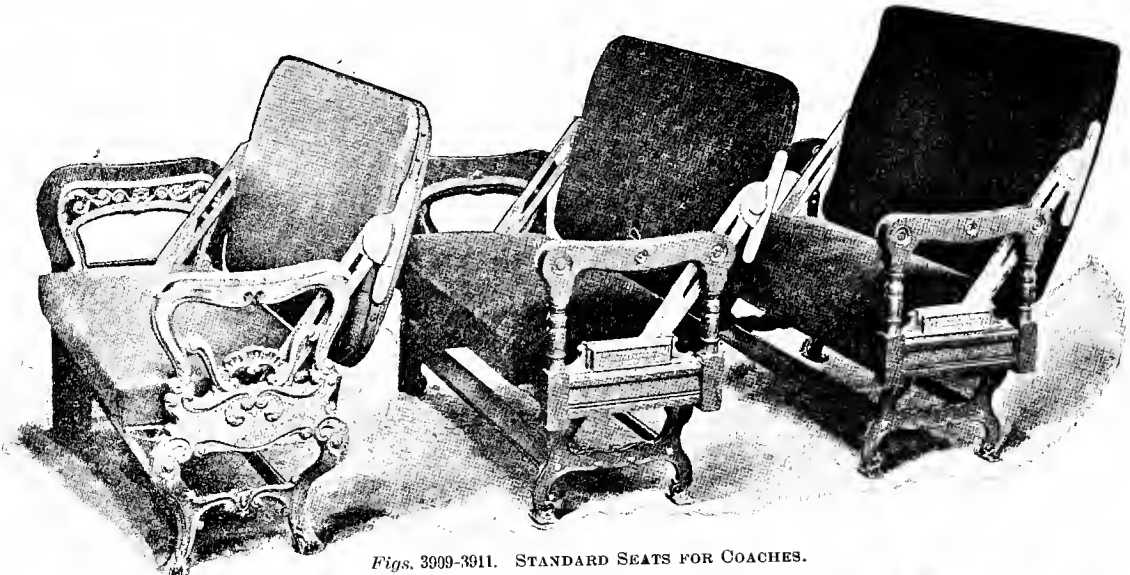

Fig. 3908. REVERSIBLE DOUBLE-BORDER SPRING FOR BEDS.

CAR SEATS AND SPRINGS. BUSHNELL MANUFACTURING COMPANY, EASTON, PA.



Figs. 3909-3911. STANDARD SEATS FOR COACHES.

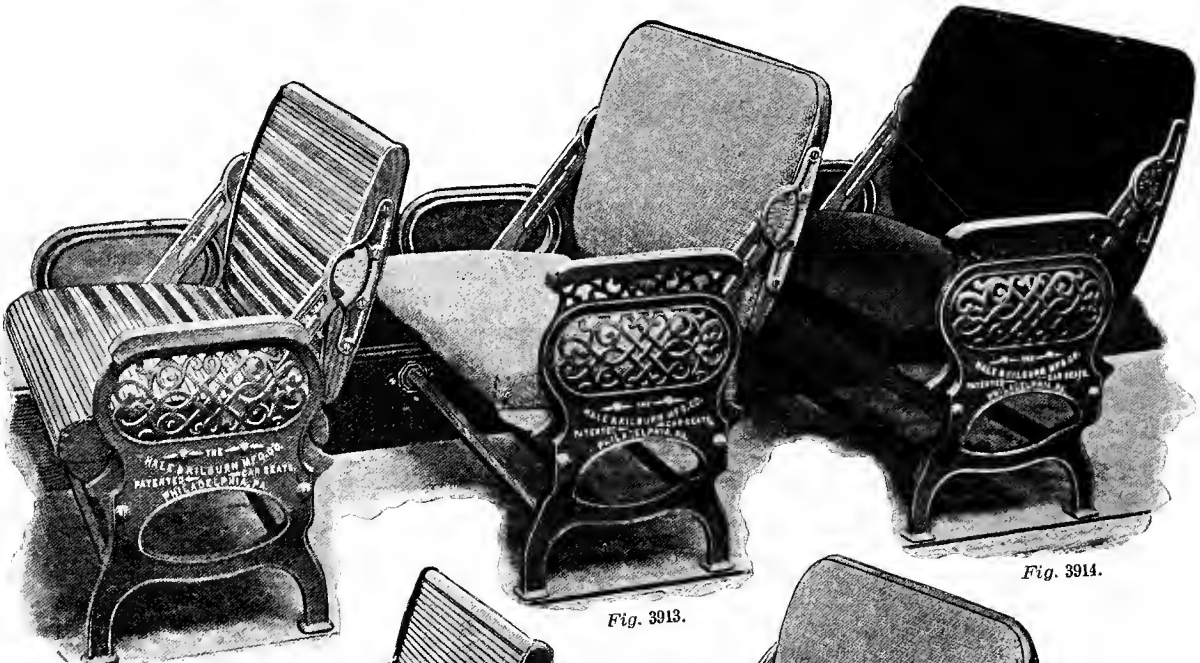

Fig. 3912.

Fig. 3913.

Fig. 3914.

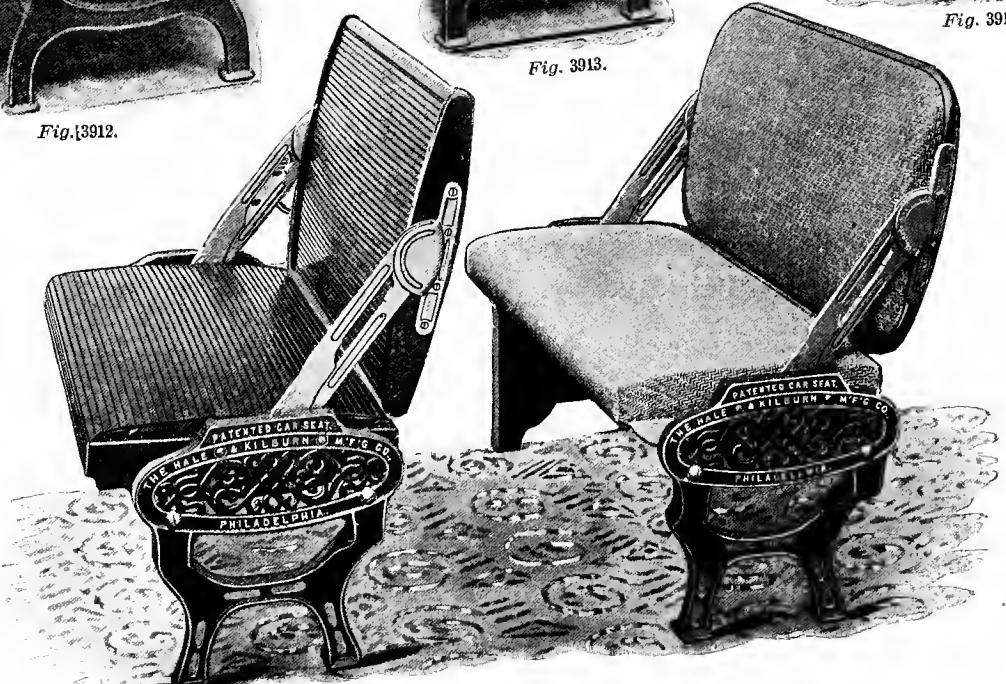

Fig. 3915.

Fig. 3916.

Figs. 3912-3914. SEATS FOR SUBURBAN AND NARROW-GAUGE CARS.

Figs. 3915-3916. SEATS FOR ELECTRIC AND CABLE CARS. Reversible Back and Tiltting Seat.

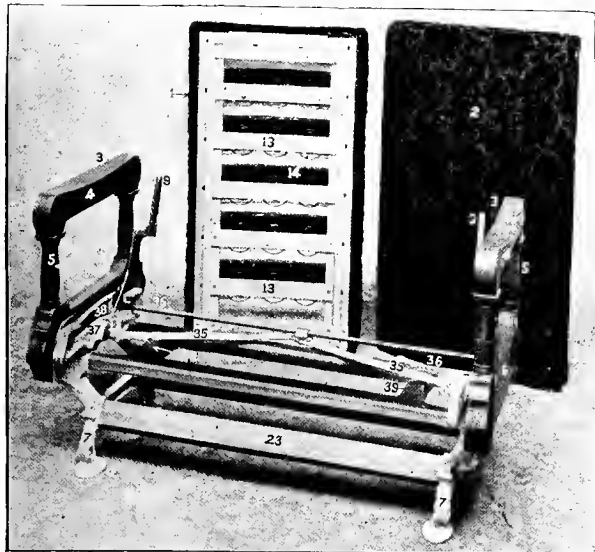

Fig. 3917. Sectional View.

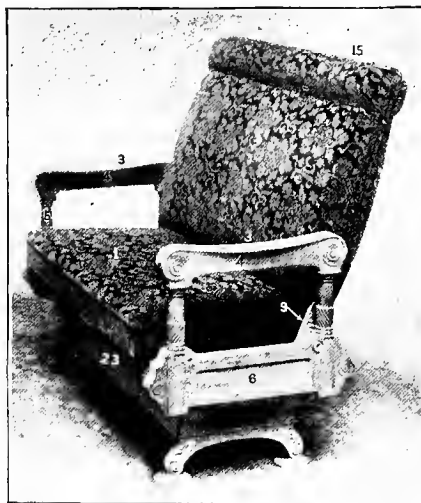

Fig. 3918. Perspective View.

IMPROVED SWING-BACK OR "WALK-OVER" CAR SEAT.

The back does not reverse, but swings over the cushion, both sides of back being upholstered.

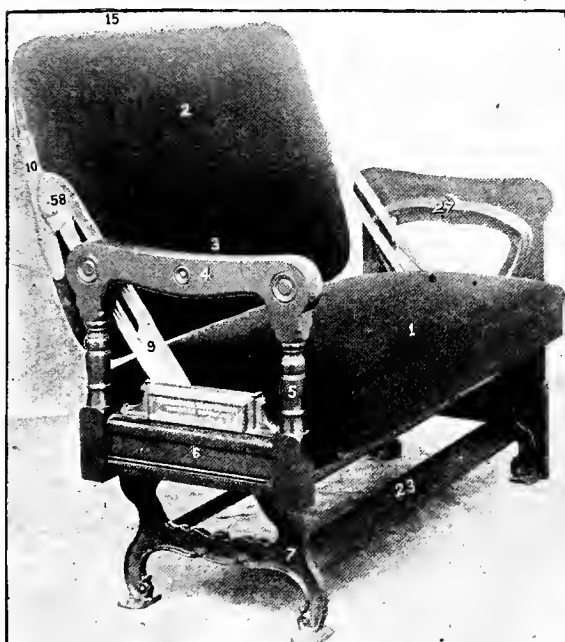

Fig. 3919. Perspective View.
No. 73. HIGH-BACK TILTING CAR SEAT.

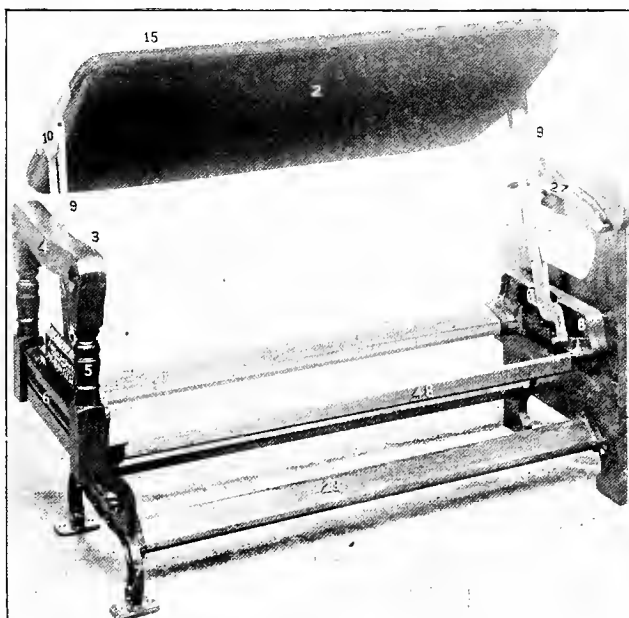

Fig. 3920. Sectional View.
No. 73. HIGH-BACK TILTING CAR SEAT.

NAMES OF PARTS OF SEATS.

Figs. 3917-3925.

1. Cushion.
2. Back.
3. Seat-end.
4. Arm-rest.
5. Seat-end Rest.
6. Seat-end Rail.
7. Cricket or Base-casting.
8. Wall Socket-casting.
9. Striker-arms.
10. Seat-back Pivot-plate.
12. Cushion-frame.
13. Spring Seat-slats.
14. Spiral Springs.
15. Back-band.
23. Foot-rail.
25. Connecting-rod.
27. Guide-casting.
29. Leg-rest.
30. Leg-rest Ratchet-casting.

31. Leg-rest Pivot-casting.
33. Leg-rest Ratchet-case.
35. Seat-tilting Lever.
36. Parallel-rod or Axle of Gear-wheel.
37. Rocker or Tilling-casting.
38. Seat-end Casting.
39. Frame Cross-bar and Lever-fulcrum.
47. Back-frame.
48. Connecting-rail.
49. Foot-rest Casting.
50. Spring-back Section.
51. Flexible Spring-edge.
52. Head-roll.
53. Rocker-casting.
54. Flexible Steel Casting.
55. Cup Casting.
56. Division-arm.
57. Push-down.
58. Seat-lock.



Fig. 3921. REVOLVING PARLOR-CAR CHAIR.
With detachable cushion

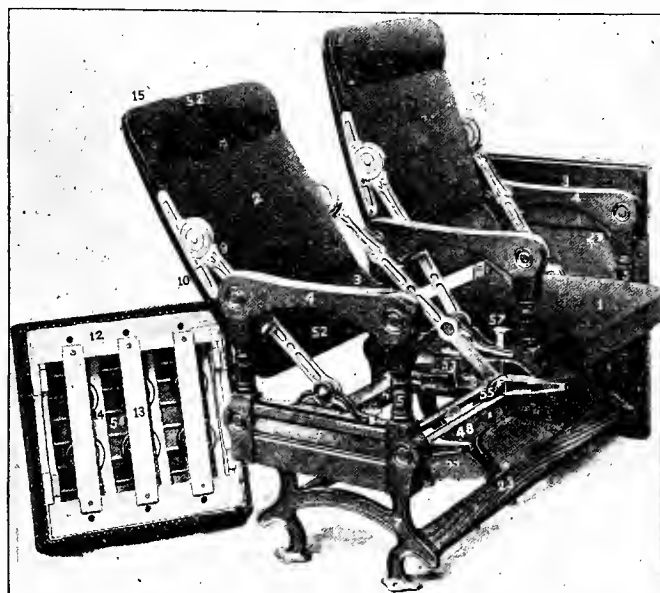

Fig. 3922. No. 61. RECLINING CAR-SEAT.
High-back, Twin Tilting Seat, Without Leg-rest.

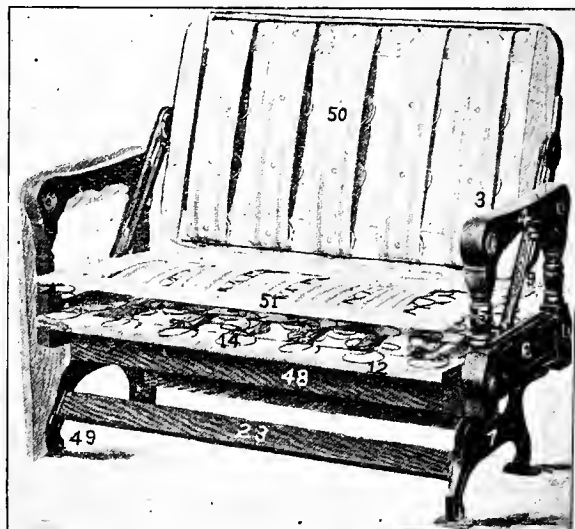

Fig. 3923. No. 73. CAR SEAT IN PROCESS OF CONSTRUCTION
With Steel Top Spring-edge Cushion and Back.

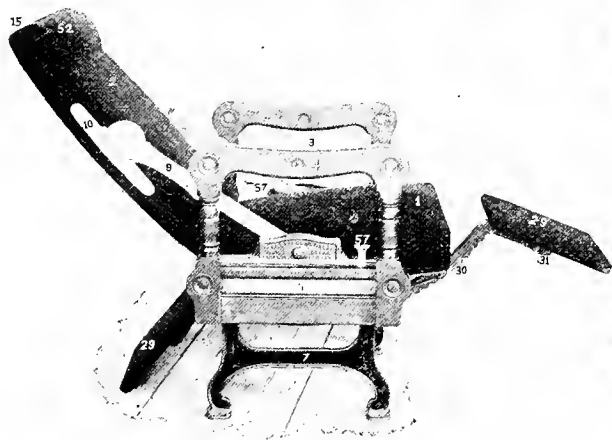

Fig. 3924. No. 64. RECLINING AND TILTING TWIN CAR-SEAT.
With Leg and Foot Rests.



Fig. 3925. No. 64.
RECLINING AND TILTING TWIN CAR-SEAT.
With Division-arm.



Fig. 3926. No. 32. Perspective View.



Fig. 2927. Detachable Cushion and Back.
PATENT PARLOR CAR CHAIRS.

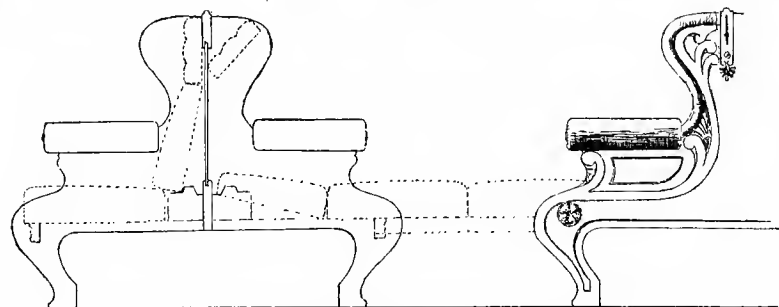

Fig. 3928. SLEEPING-CAR BERTH-SEATS.
Dotted Lines show position of cushions when drawn out to make the bed.

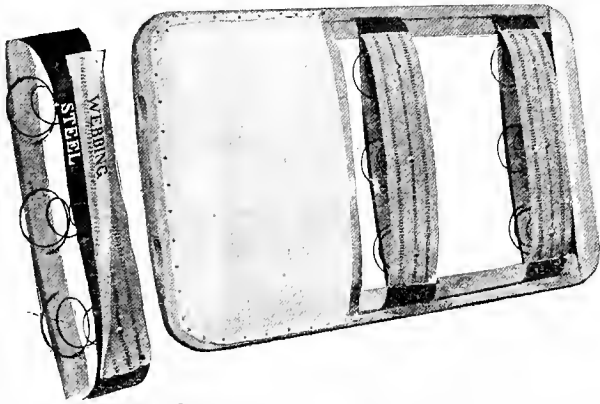
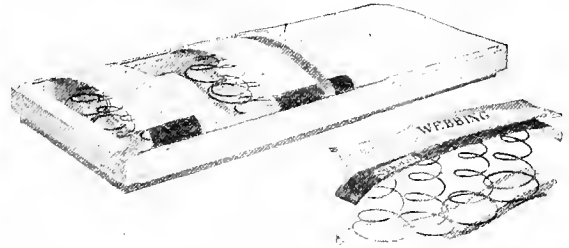

Fig. 3929. IMPROVED SECTIONAL-SPRING BACK.
One Section is detached.



Figs. 3930-3931. IMPROVED SECTIONAL-SPRING CUSHION.
With one Section detached.

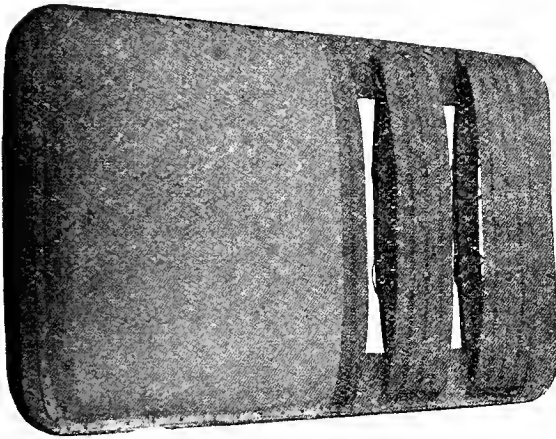
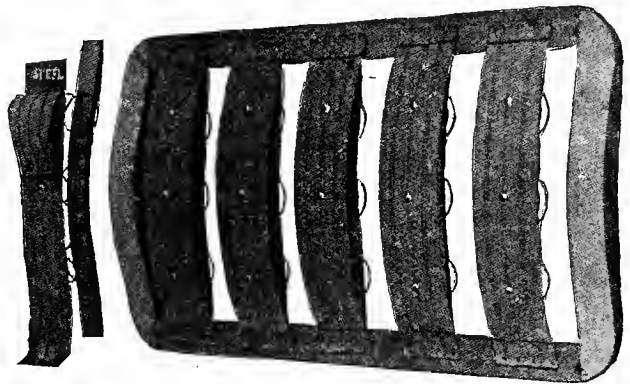

Fig. 3932. SPRING-EDGE BACK.



Figs. 3933-3934. REVERSIBLE SPRING-BACK READY FOR UPHOLSTERING.
Sectional views showing construction of Spring-edge Back.



Fig. 3935. SECTIONAL VIEWS, SHOWING THE USE OF SLAT AND WEBBING AND
THE ELASTIC SLAT EDGE.

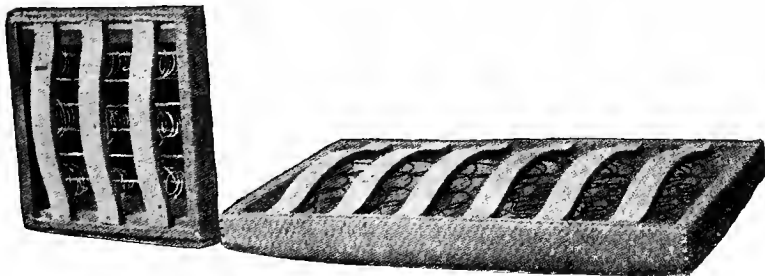

Figs. 3936-3937. REVERSE SIDE OF SINGLE AND DOUBLE RATTAN SPRING SEATS.
Showing Construction.

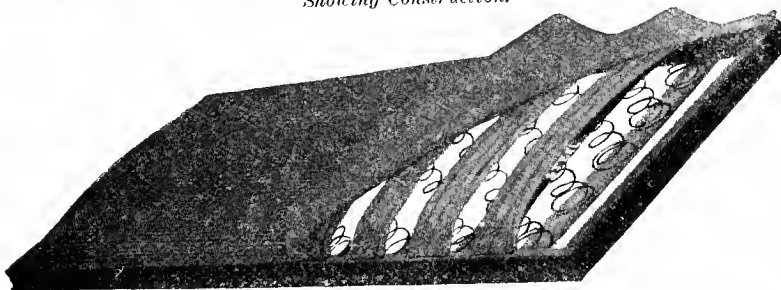

(301) Fig. 3938. SLEEPING-CAR BERTH SPRING FOR UPPER BERTH.

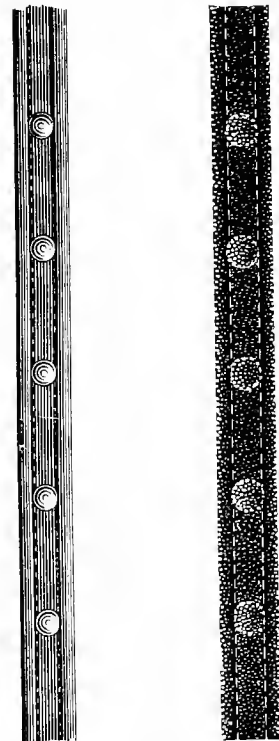

Figs. 3939-3940.
LEATHER SEAT BACK. PLUSH BANDS AND NAILS.

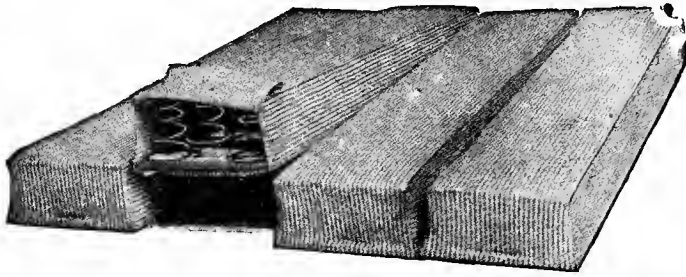

Fig. 3941.
SPRING-BED SECTIONS FOR PRIVATE AND SLEEPING CARS.

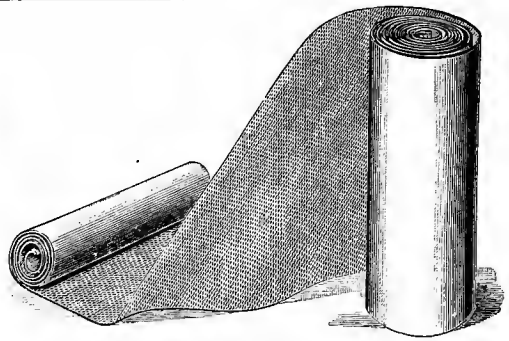

Fig. 3942.
PATENT RATTAN COVERING, CANVAS-LINED.

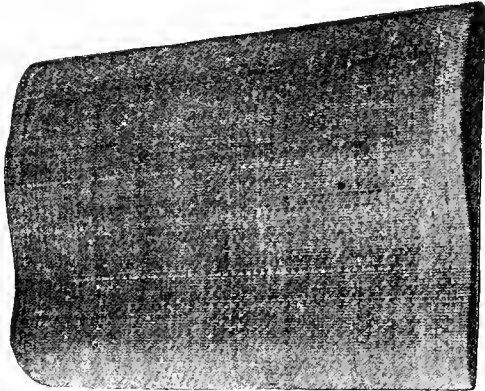

Fig. 3943.
RATTAN CROSS-SEAT SPRING-BACK WITH HEAD-REST

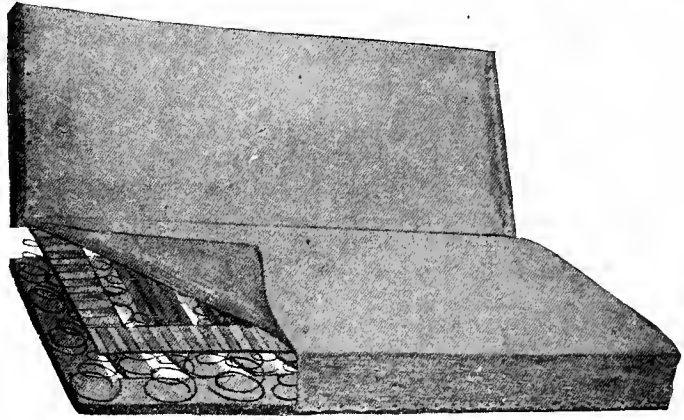

Fig. 3944.
PATENT SPRING-EDGE SLEEPING-CAR CUSHION AND BACK.

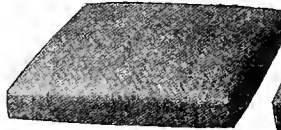

Fig. 3945. SINGLE SIDE-SEAT.



Fig. 3946. DOUBLE RATTAN SPRING CROSS-SEAT.



Fig. 3948.
DETACHED SECTION OF THE COBB PATENT
ELLIPTIC-SPRING.



Fig. 3949.
BROAD-BAND ELLIPTIC SEAT-SPRING.

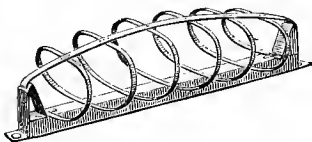

Fig. 3950.
SPIRAL ELLIPTIC SEAT-SPRING.

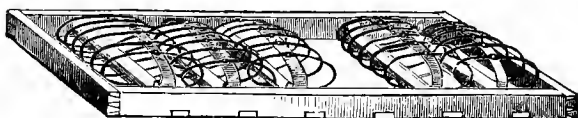

Fig. 3951.
CUSHION WITH NARROW-BAND ELLIPTIC SPRINGS.
'Cobb Patent.'

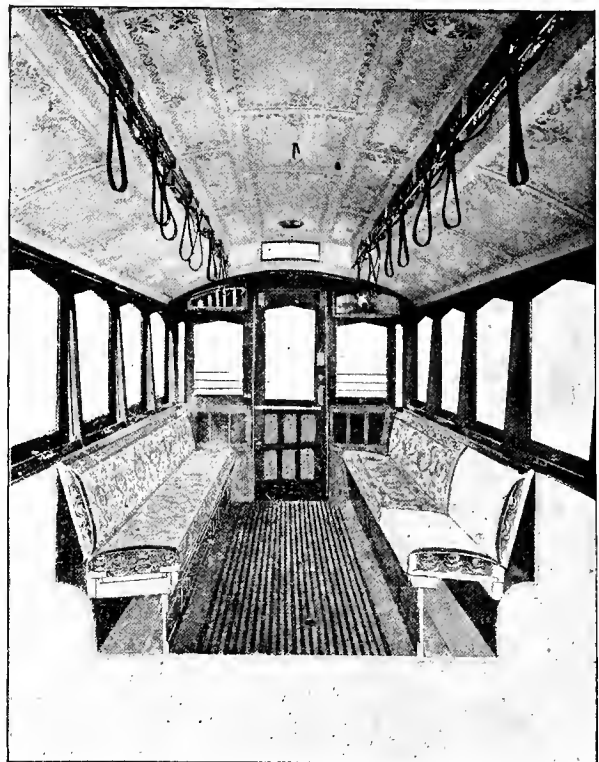

Fig. 3947. Interior View of Street Car.
METHOD OF UPHOLSTERING SIDE-SEATS OF SUBURBAN AND
STREET CARS.



Fig. 3952.
HIGH-BACK TILTING CAR-SEAT.
With Spring-edge.

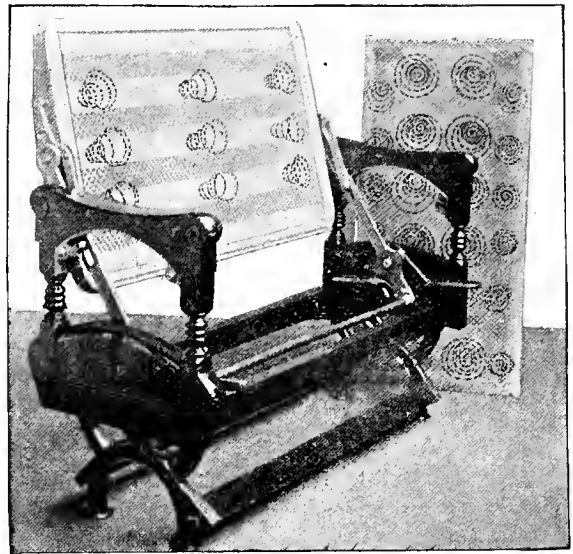

Fig. 3953. Sectional View Showing Construction and Mechanism.
HIGH-BACK TILTING CAR-SEAT.

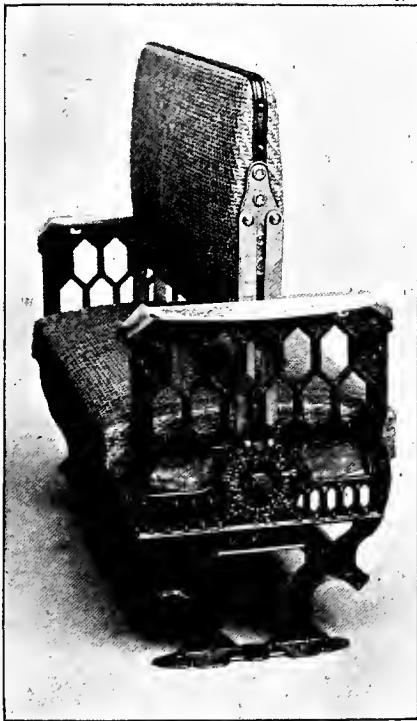

Fig. 3954.
PATENT SWING-BACK CAR-SEAT.
Seat Cushion and Back are of Woven wire
Fabric covered with Rattan.

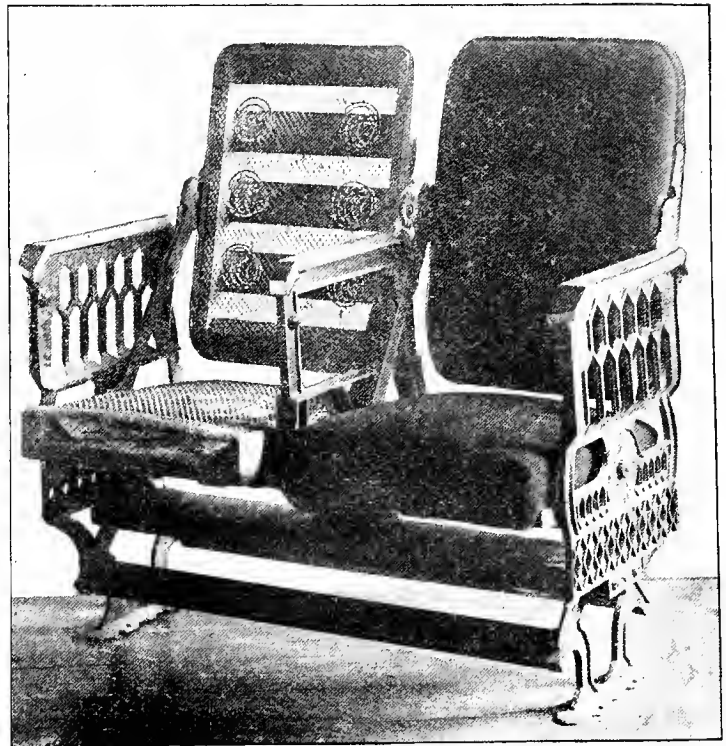

Fig. 3955. Sectional View.
DOUBLE OR TWIN CAR-SEAT. WITH DIVISION-ARM.

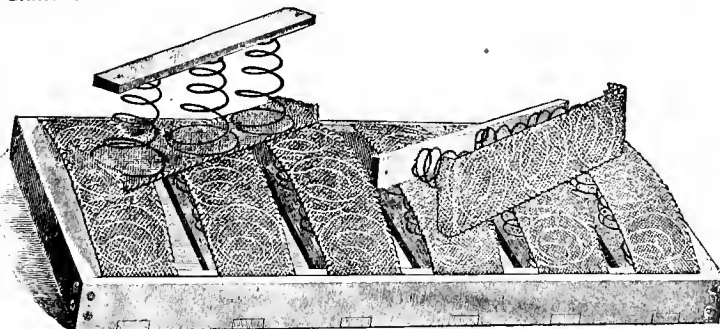

Fig. 3956. SEAT CUSHION AND DETACHED SECTIONS.
Showing Construction.
ROBERTS' PATENT WOVEN-WIRE CAR SEATS.

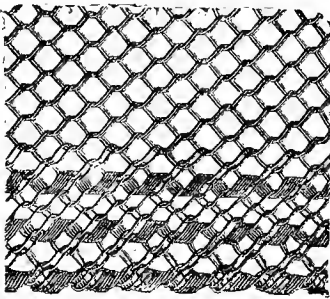

Fig. 3957. No. 2.

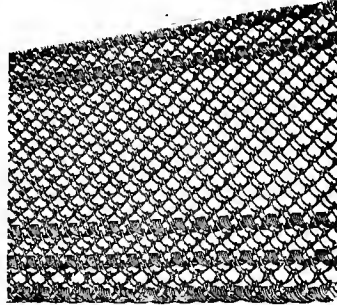

Fig. 3958. No. 1.

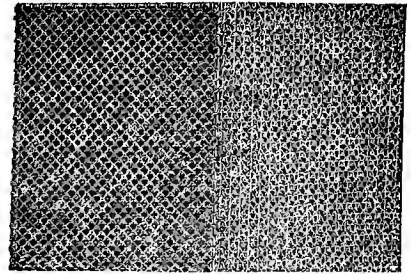

Fig. 3959. No. 3.

WOVEN WIRE FABRICS USED ON ROBERTS' WIRE SEATS.

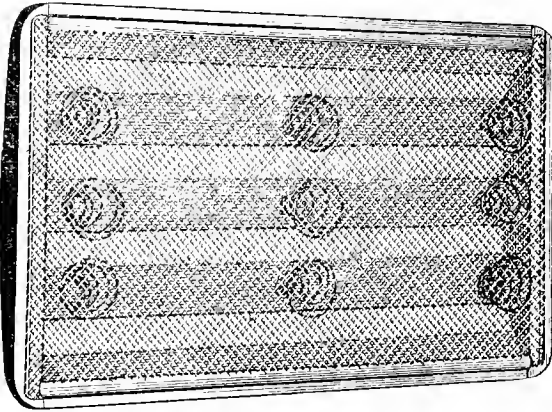

Fig. 3960. No. 7. WOVEN WIRE SEAT-BACK.

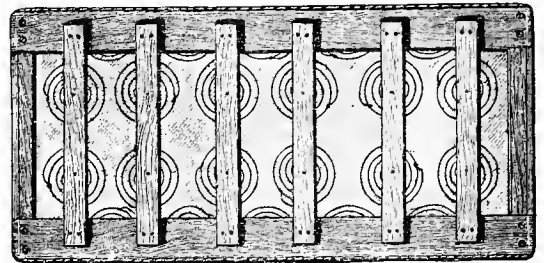

Fig. 3961. No. 4. Bottom View.
SPRING-EDGE CUSHION.

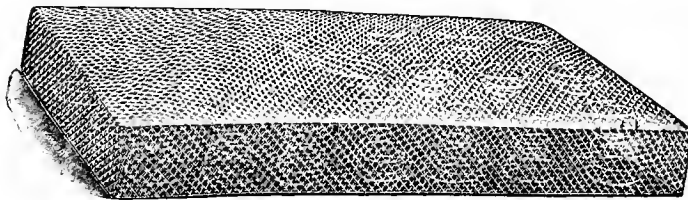

Fig. 3963. No. 27. ALL-WIRE SPRING-EDGE CUSHION.

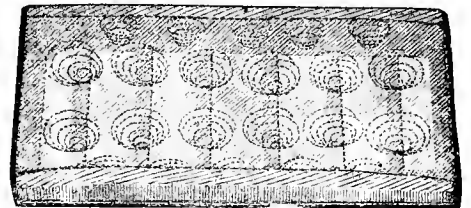

Fig. 3962.
No. 4. Top View.
SPRING-EDGE CUSHION.

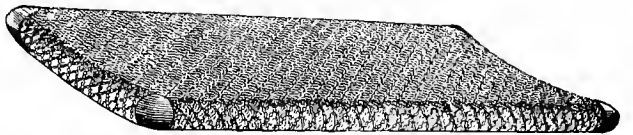

Fig. 3964. No. 29. WIRE SEAT.
For use without covering.

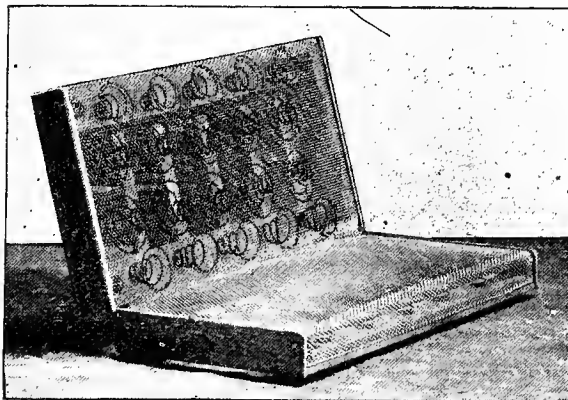

Fig. 3965. No. 18.
SLEEPING-CAR SEAT-CUSHION AND SEAT-BACK.
Covering removed to show construction.



Fig. 3966. No. 19. SLEEPING-CAR BERTH BOTTOM-SPRING.

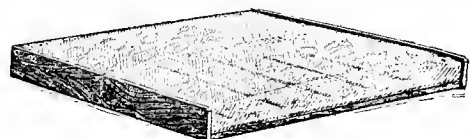

Fig. 3967.
SEAT AND BACK PULLED OUT FOR LOWER BERTH
OF SLEEPING CAR.

Numbers refer to List of Names on following Page.



Fig. 3968. EXTRA-HIGH AND CURVED-BACK RATTAN SEAT.

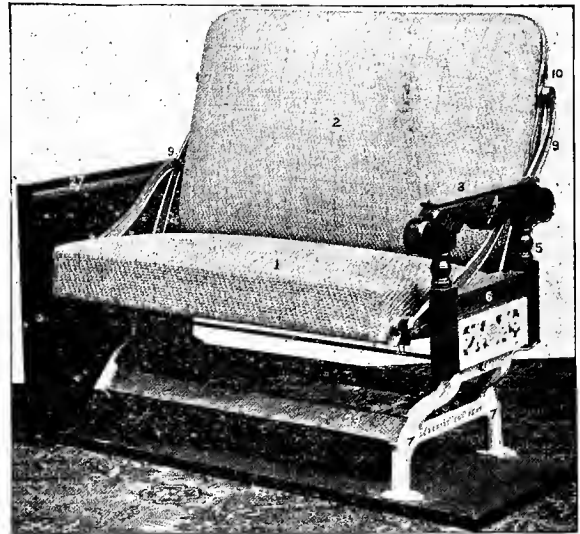

Fig. 3969. STANDARD RATTAN CAR-SEAT.

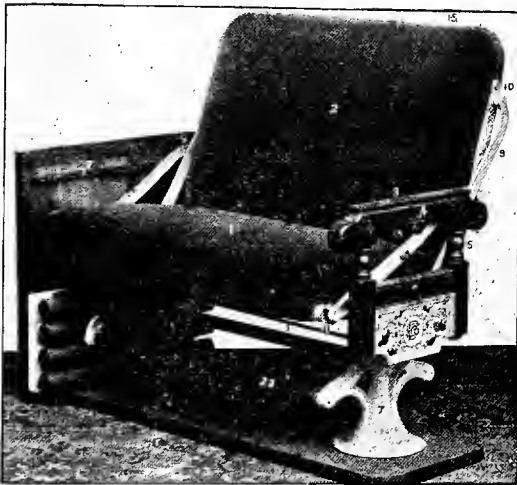

Fig. 3970. STANDARD PLUSH CAR-SEAT.

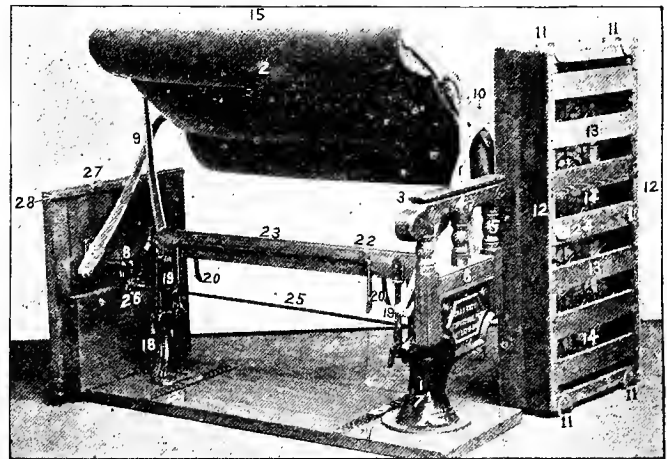

Fig. 3971. EXTRA-HIGH-BACK SEAT
Cushion removed and seat tilted to show mechanical construction.



Fig. 3972. EXTRA-HIGH-BACK SEAT.
With Head-roll and Adjustable Foot-rest.

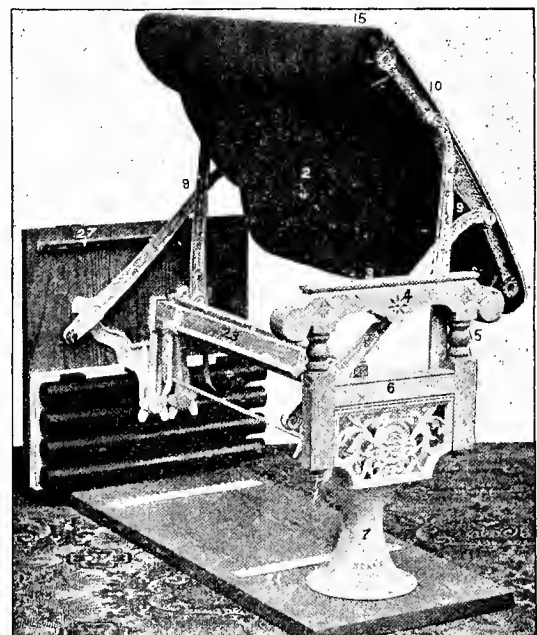
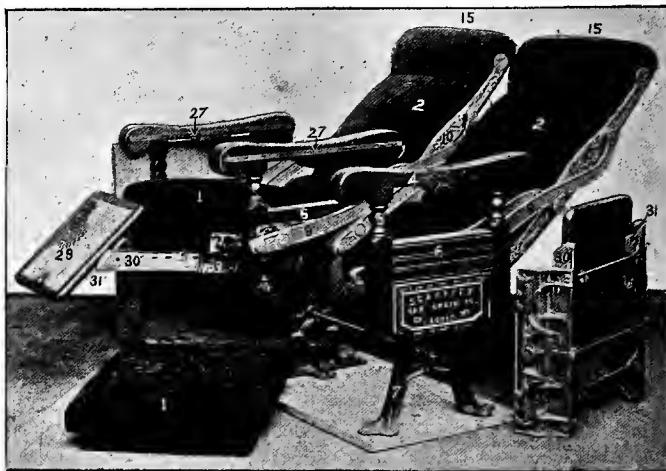

Fig. 3973. EXTRA-HIGH-BACK SEAT.
Tilted to Show Mechanical Parts.



Figs. 3974-3975. No. 59. SCARRITT-FORNEY RECLINING TWIN-SEATS.

NAMES OF PARTS.

Figs. 3967-3976.

1. Seat-cushion.
2. Seat-back Cushion.
3. Seat-end.
4. Arm-rest.
5. Seat end Rest.
6. Seat-end Rail.
7. Seat-stand.
8. Wall Pivot-plate.
9. Seat-back Reversing-arms.
10. Seat-back Pivot-plate.
11. Seat Socket-castings.
12. Seat-frame.
13. Seat-slats.
14. Seat-springs.
15. Seat-back.
16. Seat-back Frame.

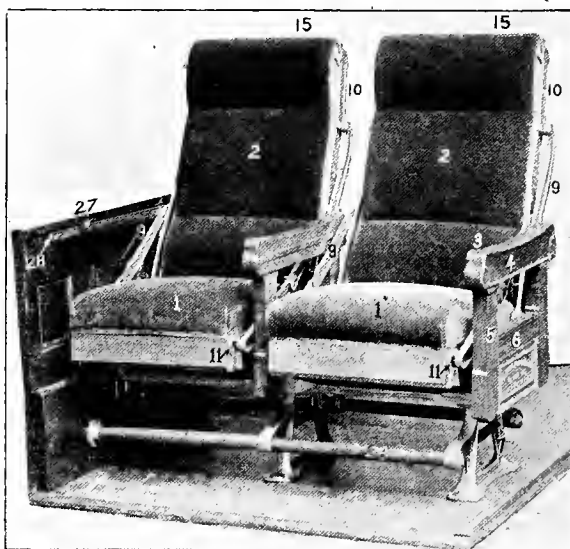

17. Seat-back Springs.
18. Foot-rest Stand.
19. Foot rest Arm.
20. Foot-rest Pawl.
21. Foot-rest Ratchet.
22. Foot-rest Pawl-stop.
23. Foot-rest Stop.
25. Seat-stand Tie-rod or Strut.
26. Seat-stand Tie-rod Casting.
27. Friction-plate.
28. Friction-plate Strip.
29. Leg-rest.
30. Leg-rest Slide.
31. Leg-rest Casting.
32. Socket-casting and Guide for Leg-rest.
33. Spring for Retaining-jaw.
34. Retaining-jaw.

Fig. 3976. No. 42. SCARRITT-FORNEY TWIN-SEAT, WITHOUT LEG-REST.

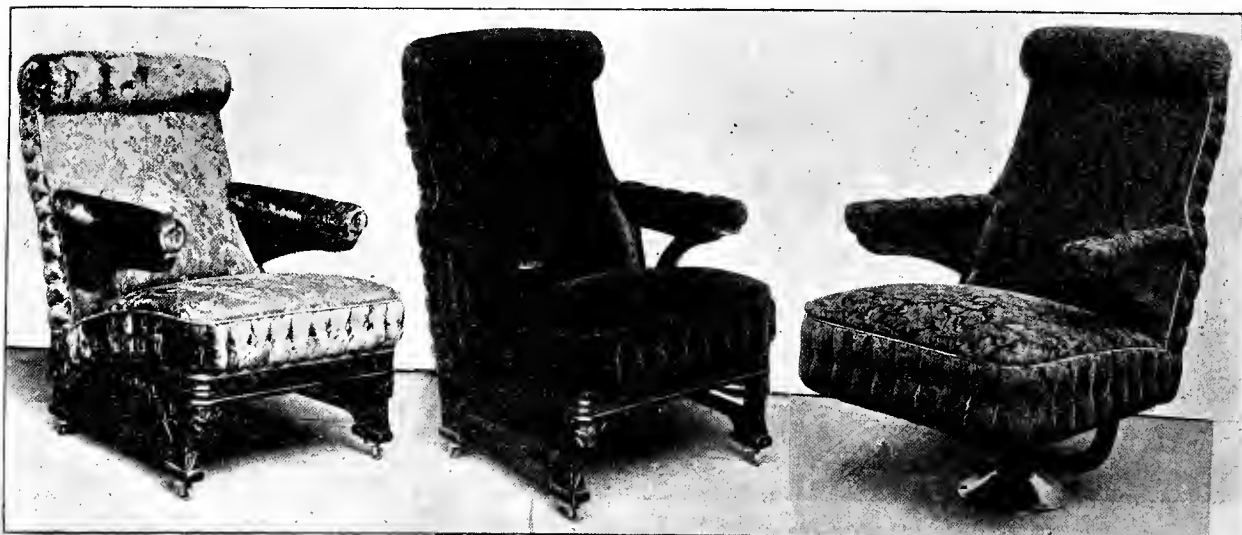

Figs. 3977-3979. SCARRITT'S DRAWING-ROOM-CAR CHAIRS.

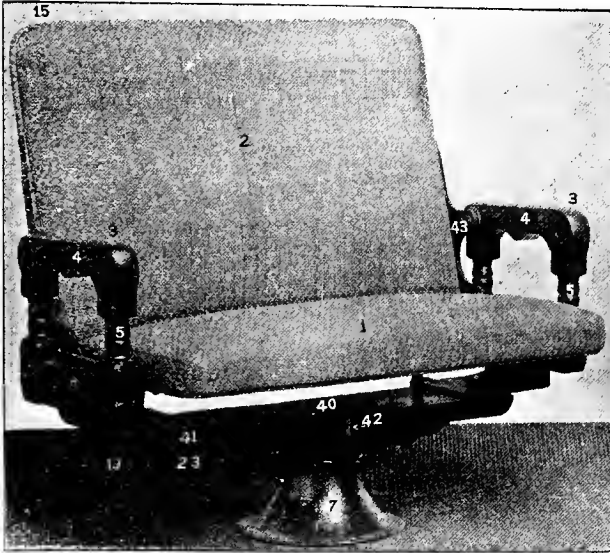

Fig. 3980. REVOLVING AND FOLDING SEAT.



Fig. 3981. TWIN-SEAT WITH DIVISION ARM.

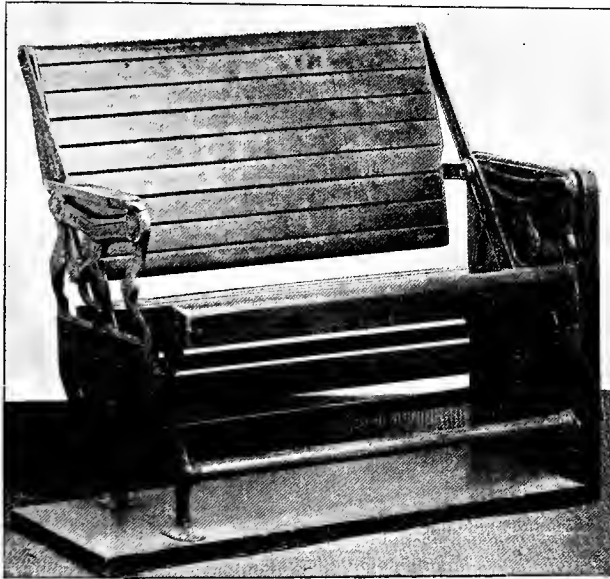

Fig. 3982. SWING-BACK SLAT-SEAT.

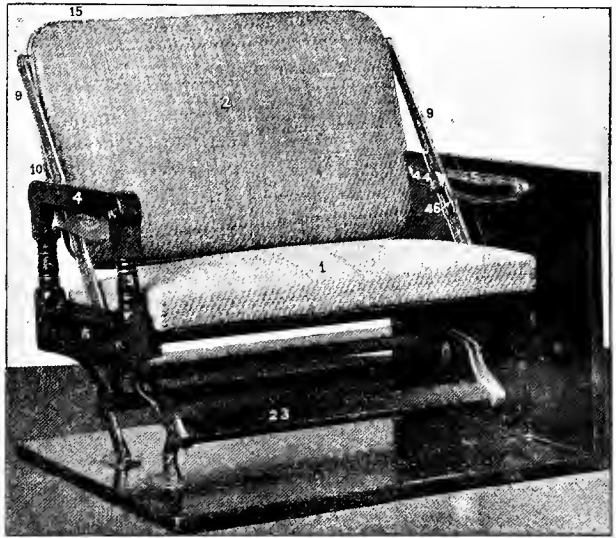
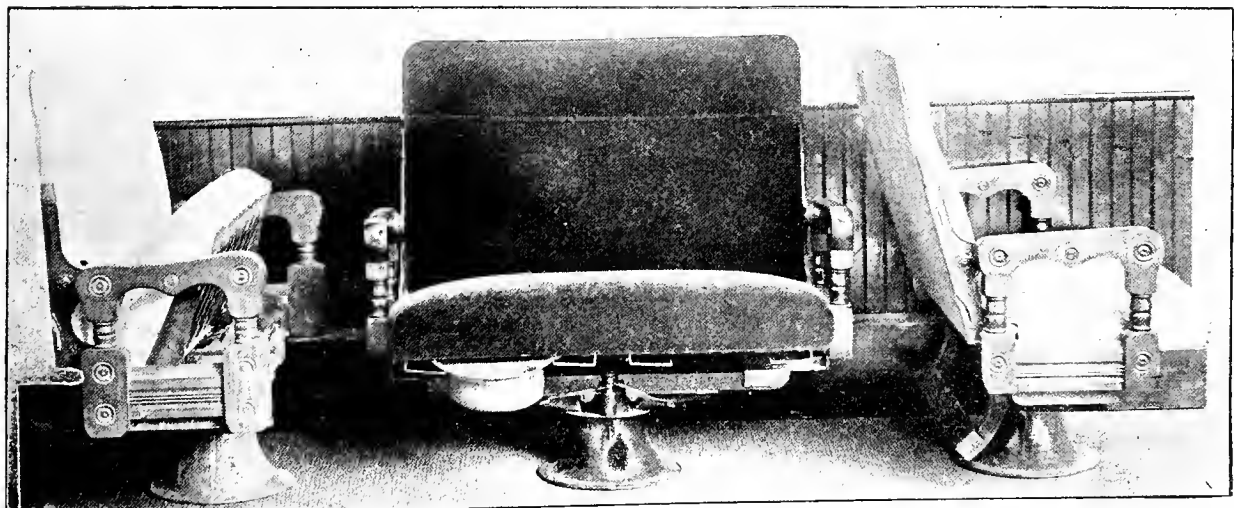

Fig. 3983. SWING-BACK RATTAN-SEAT.



Figs. 3984-3986. REVOLVING AND FOLDING SEATS.
CAR SEATS, WAKEFIELD RATTAN COMPANY.

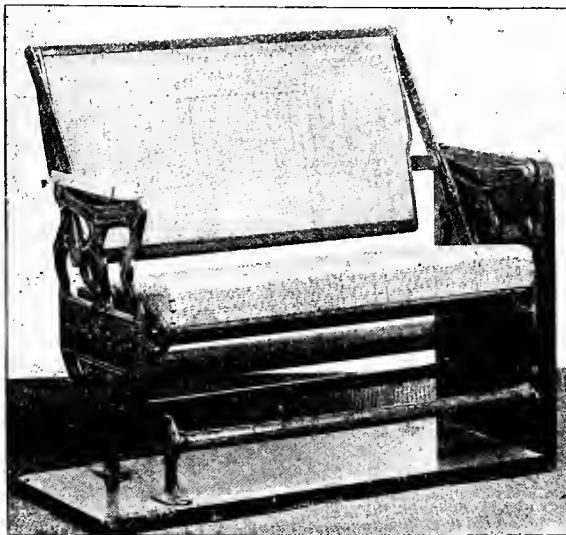

Fig. 3987. SWING-BACK RATTAN SEAT FOR STREET-CARS.



Fig. 3988. UPHOLSTERED RATTAN CHAIR FOR PARLOR-CARS.



Fig. 3989. RATTAN REVOLVING-CHAIR FOR PARLOR-CARS.

CAR-SEATS AND CHAIRS. WAKEFIELD RATTAN COMPANY.

NAMES OF PARTS OF SEATS. Figs. 3980-3989.

- | | |
|-------------------------|-----------------------------|
| 1. Cushion. | 15. Seat-back. |
| 2. Back. | 19. Arm and Seat Support. |
| 3. Arm. | 23. Foot-rail. |
| 4. Arm-cap. | 40. Connecting Frame-rail. |
| 5. Arm-post. | 41. Seat-support Extension. |
| 6. Arm-rail. | 42. Spring-lock. |
| 7. Seat-stand. | 43. Revolving-base Top. |
| 9. Back-arm (swinging). | 44. Arm-crank. |
| 10. Back Pivot-plate. | 45. Wall-end Slide. |

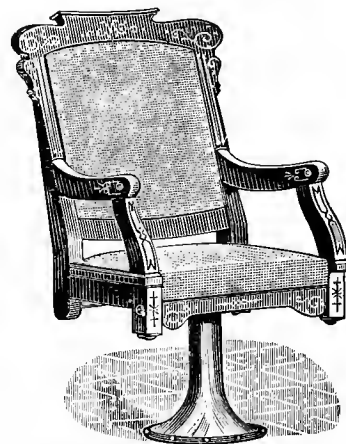

Fig. 3990. PARLOR-CAR CHAIR. With "Spring-edge" Cane Seat.

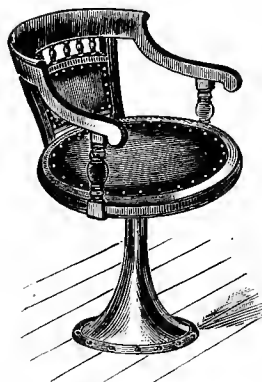

Fig. 3991. PARLOR-CAR SMOKING-CHAIR. With Rattan or Cane Seat.

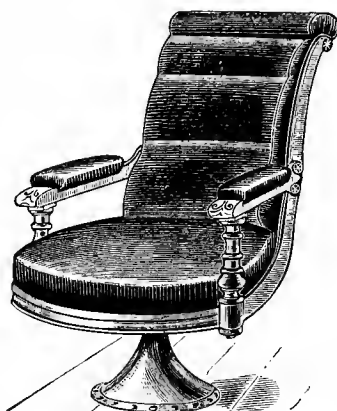

Fig. 3992. PARLOR-CAR CHAIR. (Detachable Back and Seat.)

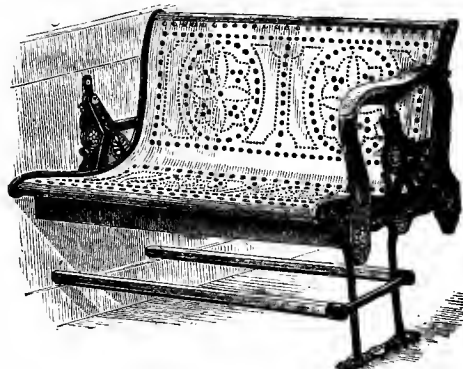

Fig. 3993. PERFORATED-VENEER CAR-SEAT. With Buntin's Seat-ends.

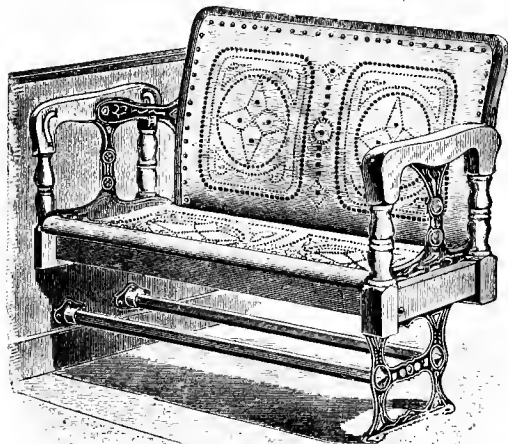

Fig. 3994. PERFORATED-VENEER CAR-SEAT.

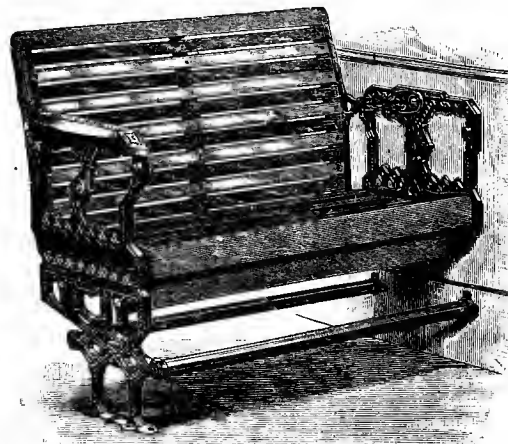

Fig. 3995. EMIGRANT CAR-SEAT. With Gardner's Geared Seat-arm.



Figs. 3996-3997.
THE HITCHCOCK RECLINING AND REVOLVING CHAIR.

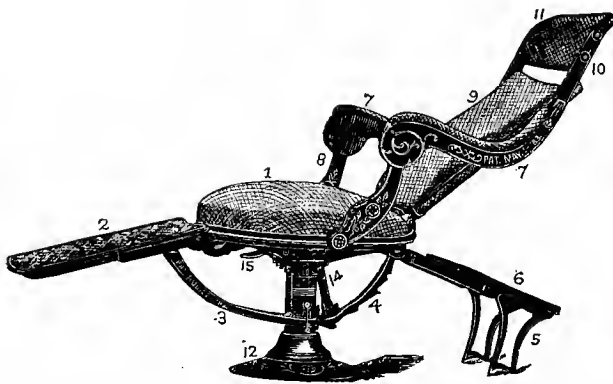

Fig. 3998.
THE HARTLEY RECLINING-CHAIR, RATTAN UPHOLSTERING.



Fig. 3999.



Fig. 4000.

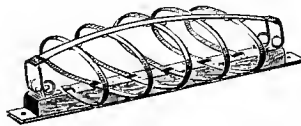

Fig. 4001.
JUERGENS SPIRAL-ELLIPTIC SEAT-SPRINGS.

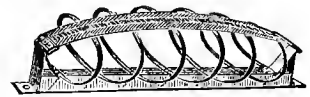

Fig. 4002.

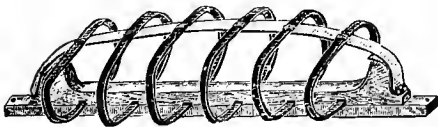

Fig. 4003.
Z. COBB'S NARROW-BAND ELLIPTIC SEAT-SPRINGS.

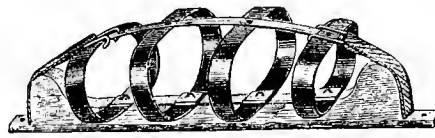

Fig. 4004.
H. B. COBB'S BROAD-BAND ELLIPTIC.

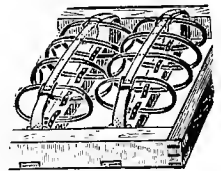

Fig. 4005.
ARRANGEMENT OF SPRINGS.

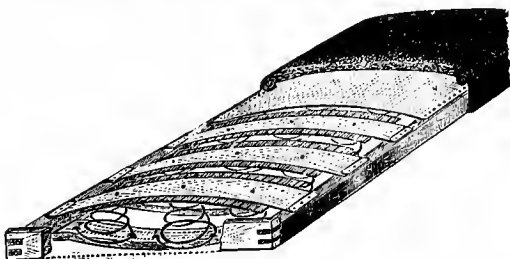

Fig. 4006.

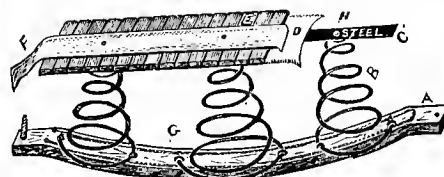

Fig. 4007.



Fig. 4008. DETACHED SECTION
OF SPRINGS AND WEBBING.

PATENT FLEXIBLE-TOP SECTIONAL SEAT-SPRING, WITH CURVED SLATS.

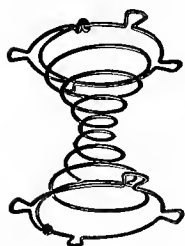

Fig. 4009.
SPIRAL SEAT SPRING.

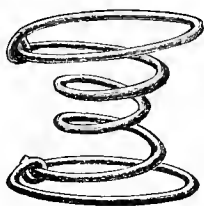

Fig. 4010.
KNOTTED SPIRAL SEAT-SPRING.



Figs. 4011-4012.
SPIRAL SEAT AND BACK SPRINGS.



Fig. 4013.
"EUREKA" SPIRAL
SEAT-SPRING.

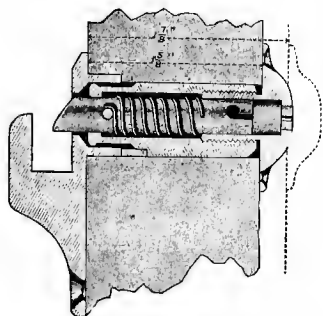
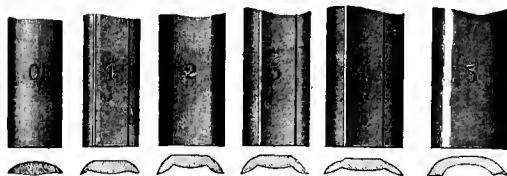
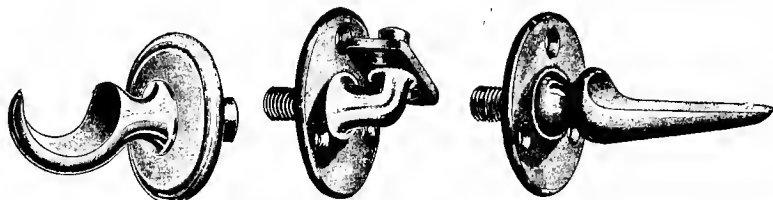

Fig. 4022.
KIRBY'S SEAT-LOCK FOR WOOD
SEAT-ENDS.



Figs. 4023-4028.
SEAT-BACK MOLDINGS.
White metal from 1/2 in. flat to 3/4 in. half-round.



Figs. 4014-4016. SEAT ARM-REST BRACKETS.

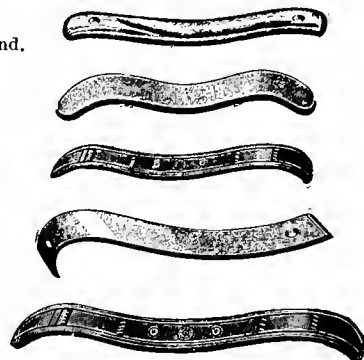

Figs. 4017-4021. SEAT-ARM CAPS.
1 1/2 ins. wide x 12-16 ins. long.

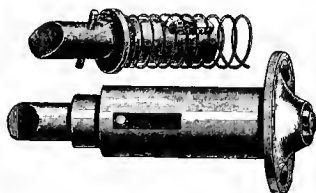

Figs. 4029-4030.
SEAT-BACK ARM-LOCK, BOLT AND SPRING.

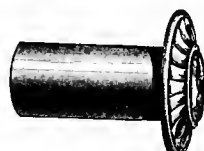
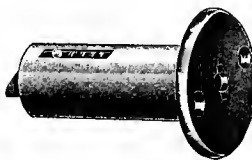
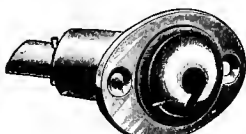

Figs. 4031-4033.
SEAT-BACK ARM-LOCKS WITH ESCUTCHEONS.



Figs. 4034-4039. SEAT-ARM RIVETS.

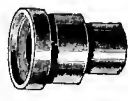

Figs. 4040-4041.
SEAT-ARM THIMBLES.



Fig. 4042.
JOINT-BOLT AND WASHER.

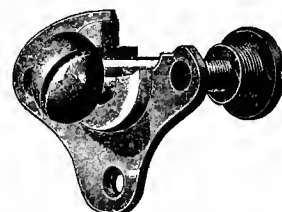
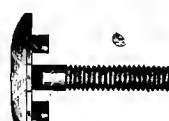
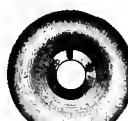

Fig. 4043. SEAT-ARM PIVOT-BOLT.



Figs. 4044-4046. SEAT-ARM WASHERS.



Figs. 4047-4050. SEAT-ARM WASHERS AND MACHINE BOLTS FOR FORNEY-SEATS.

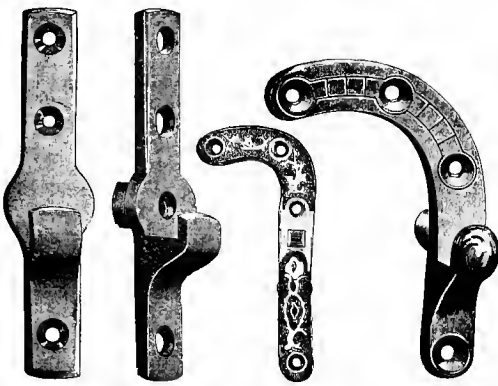

Figs. 4051-4052.
STRAIGHT SEAT-ARM STOPS.

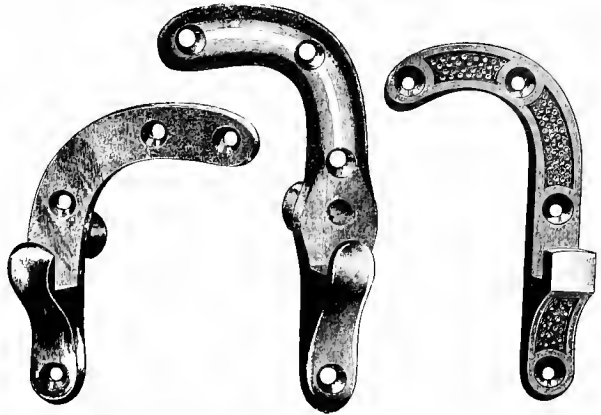

Figs. 4053-4057. CURVED SEAT-ARM STOPS.
Made right and left handed.

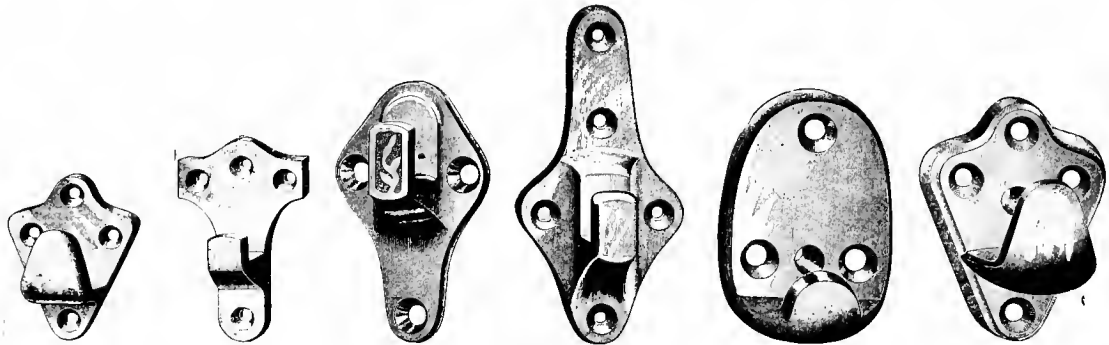

Figs. 4959-4064.
SHIELD AND OVAL SHAPED SEAT-ARM STOPS.

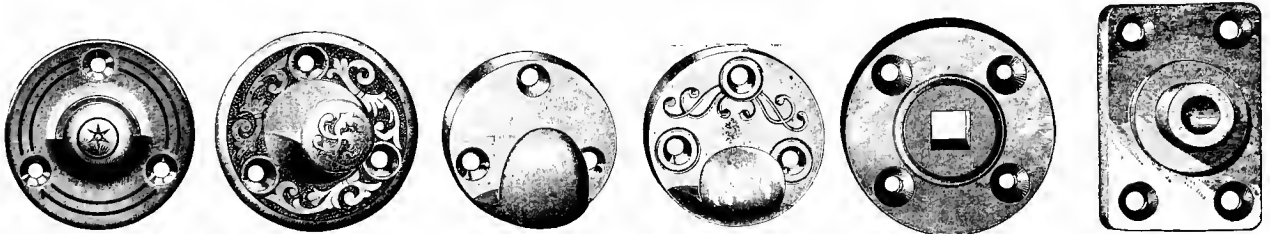

Figs. 4065-4068.
ROUND SEAT-ARM STOPS.
With or without locks.

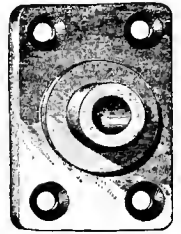

Figs. 4069-4070.
SEAT-ARM PIVOT-PLATES.

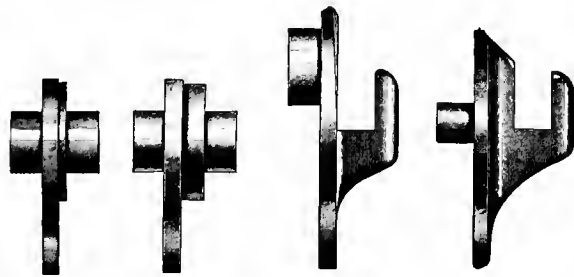

Figs. 4071-4072.
SEAT-ARM PIVOT-PLATES.

The thicker ones are for the side of car to prevent the arm from striking the woodwork when the back is being turned.

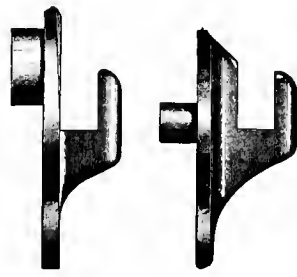

Figs. 4073-4074.
SEAT-ARM STOPS.

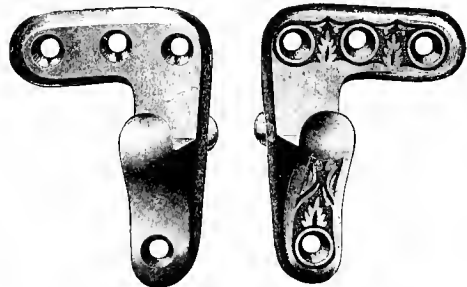

Figs. 4075-4076.
SEAT-ARM STOPS.

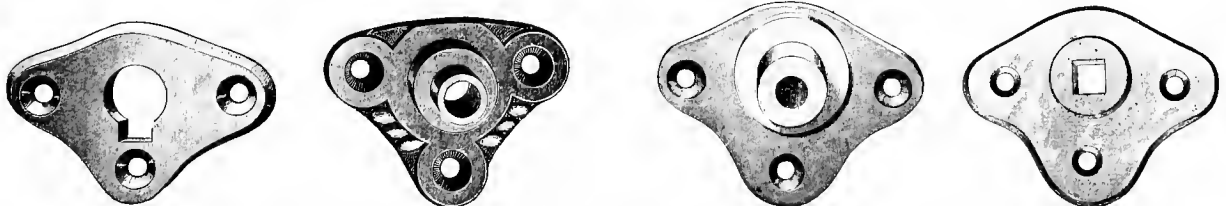

Figs. 4077-4080.
SEAT-ARM PIVOT-PLATES.

The thicker ones are for the end of seat next to side of car and prevent the arm from striking the woodwork when the back is being turned.

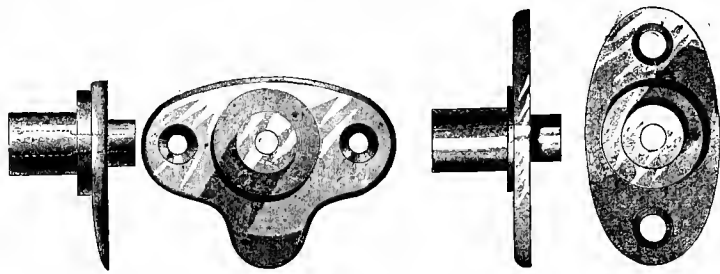

Figs. 4081-4084. SEAT-ARM PIVOT-PLATES.

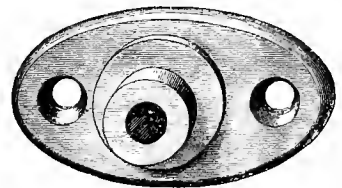
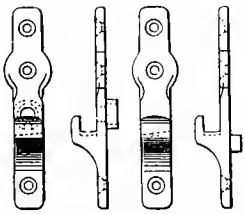

Fig. 4085. SEAT-ARM PIVOT-PLATE. With solid nipple.



Figs. 4087-4090. With lock. Without lock. SEAT-ARM STOPS.

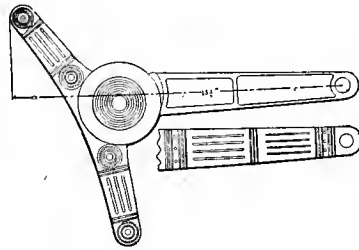

Fig. 4092. PIVOTED SEAT-BACK ARM.

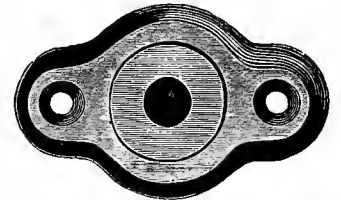

Fig. 4086. SEAT-ARM PIVOT-PLATE.



Fig. 4105. SEAT-CORNER. Sheet Brass.

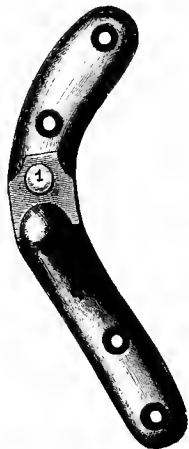

Fig. 4091. CURVED SEAT-ARM STOP, WITH LOCK.

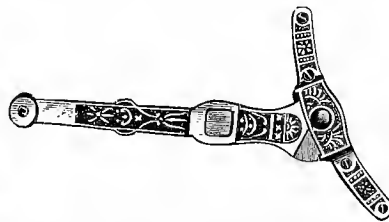
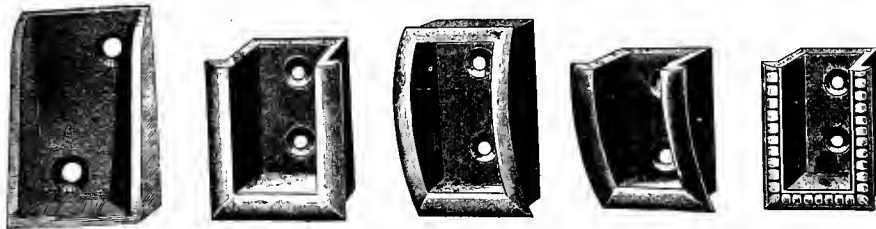
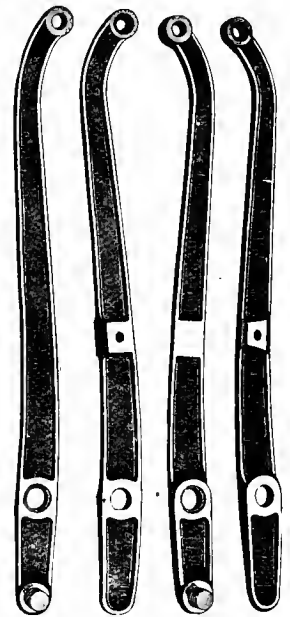

Fig. 4093. COBB'S PIVOTED SEAT-ARM. Other Seat-arms are shown in Figs. 3901-3987.



Figs. 4094-4098. SEAT-RAIL BRACKETS OR SOCKETS.



Figs. 4099-4102. SEAT-BACK ARMS FOR FORNEY SEATS.

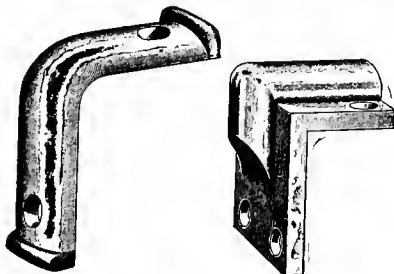

Figs. 4103-4104. SEAT-BACK CORNERS.



Fig. 4106. IRON SEAT-END WITH WOOD ARM-REST. (For Forney Seats.)



Fig. 4107. SEAT-STAND.



Fig. 4108. SEAT-STAND.



Fig. 4109. REVOLVING-CHAIR PEDESTAL.

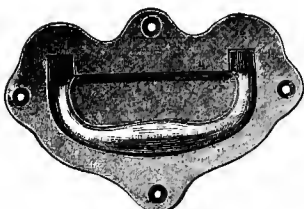

Fig. 4110. SEAT-PULL.

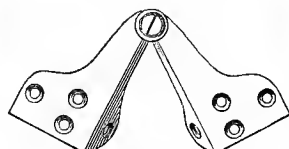

Fig. 4111. SEAT-HINGE.



Figs. 4112-4115. CHAIR AND SOFA CASTERS.



Fig. 4116. SOFA ARM-REST FIXTURE.

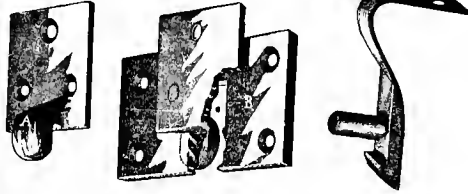

Fig. 4117. Fig. 4118. Fig. 4119. Spring-catch. SOFA ARM-REST FIXTURES.



Fig. 4120. Pin Bushing.

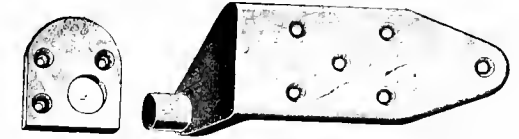

Fig. 4121. Pin Plate.



Fig. 4122. Catch Plate.

SOFA ARM-REST FIXTURES.



Figs. 4124-4125. SOFA BACK PIVOT-HINGE AND PLATE.



Figs. 4126-4127. SOFA-HINGES.



Fig. 4123. Pin.

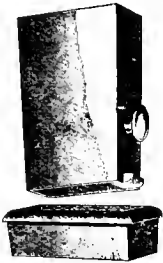

Fig. 4130. SOFA BACK-LEG SOCKET.

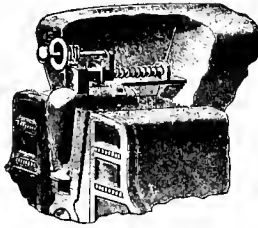

Fig. 4128. SOFA ARM-REST IN POSITION.

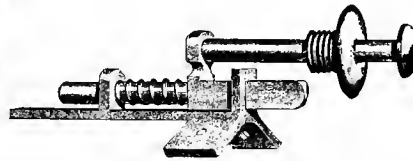
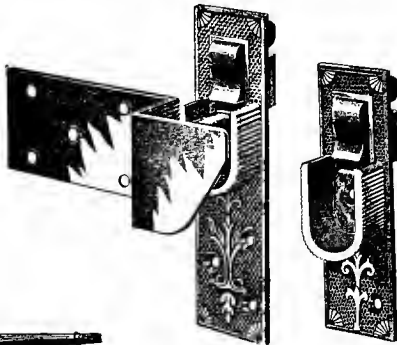

Fig. 4129. SOFA ARM-REST BOLT.



Figs. 4131-4132. SOFA RAIL-END AND SOCKET.



Figs. 4131-4135. SOFA-BED HINGE AND SOCKET.

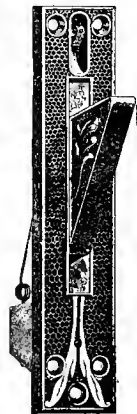

Fig. 4136. SOFA-BED SUPPORT.

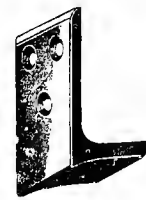

Fig. 4137. STRIKE-PLATE.



Figs. 4143-4144. UPPER-BERTH CATCH AND PLATE.

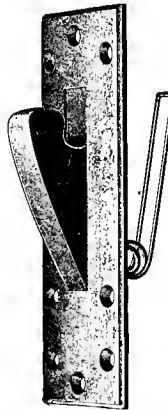

Fig. 4140. SOFA-LEG HOOK.

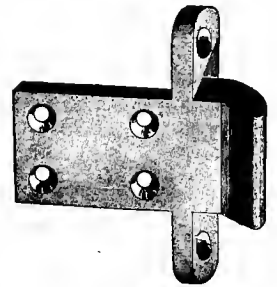

Fig. 4141. SEAT PULL.



Fig. 4142. SEAT PULL.



Fig. 4138. SOFA-PULL, SOFA-CRANK AND SOFA-BOLT.

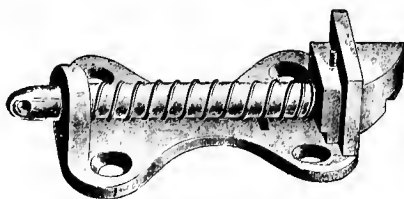
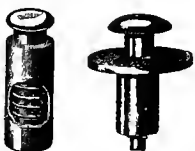
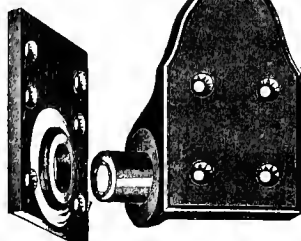

Fig. 4139. SOFA-BOLT.



Figs. 4145-4146. BERTH-RATTLE STOPS.



Figs. 4147-4148. BERTH HINGE AND PLATE.

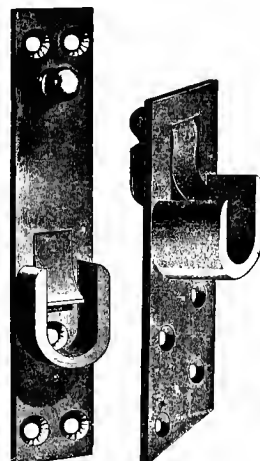

Figs. 4149-4150. UPPER-BERTH PIVOT SOCKETS.



Figs. 4151-4152. HEAD-BOARD PIVOT AND SOCKET.

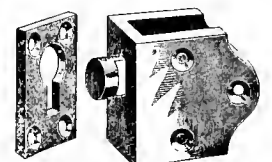

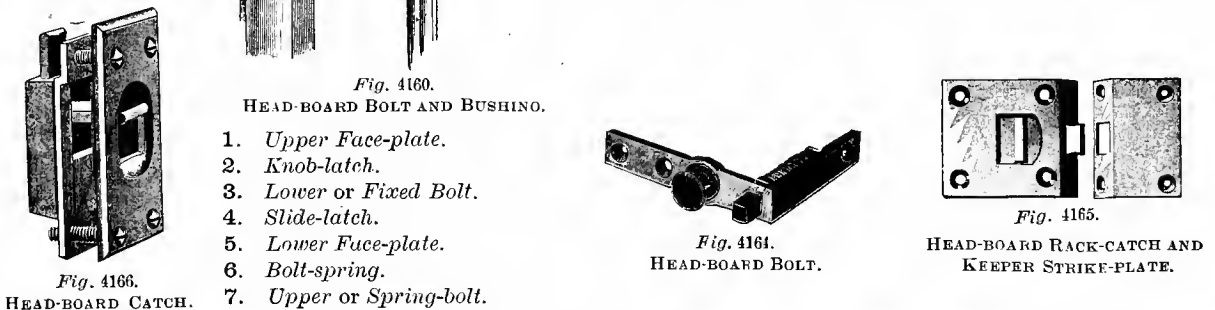
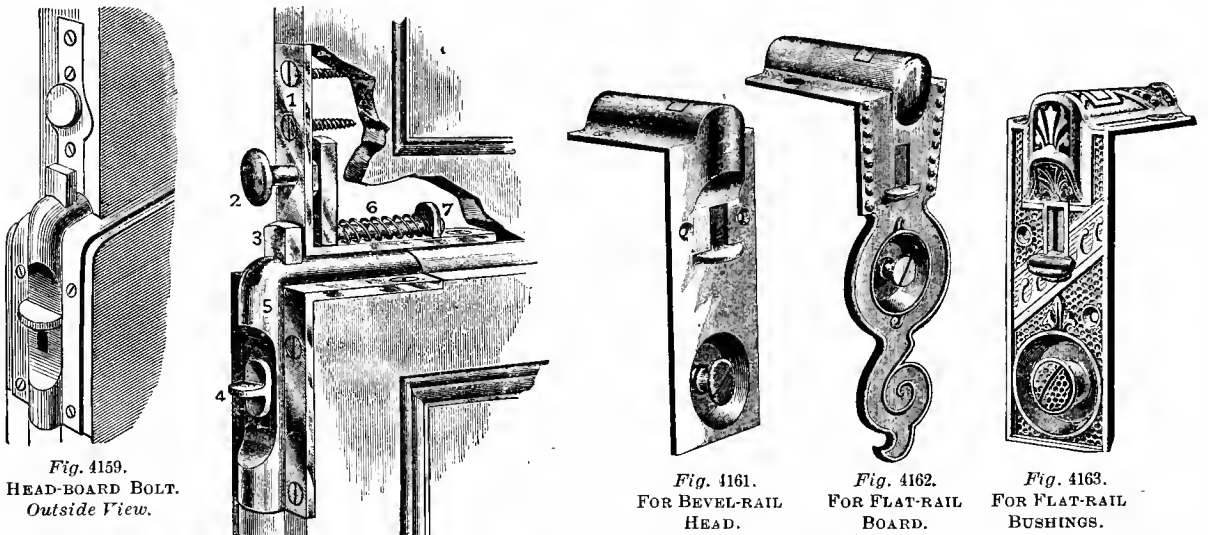

- Fig. 4160. HEAD-BOARD BOLT AND BUSHING.
1. Upper Face-plate.
 2. Knob-latch.
 3. Lower or Fixed Bolt.
 4. Slide-latch.
 5. Lower Face-plate.
 6. Bolt-spring.
 7. Upper or Spring-bolt.

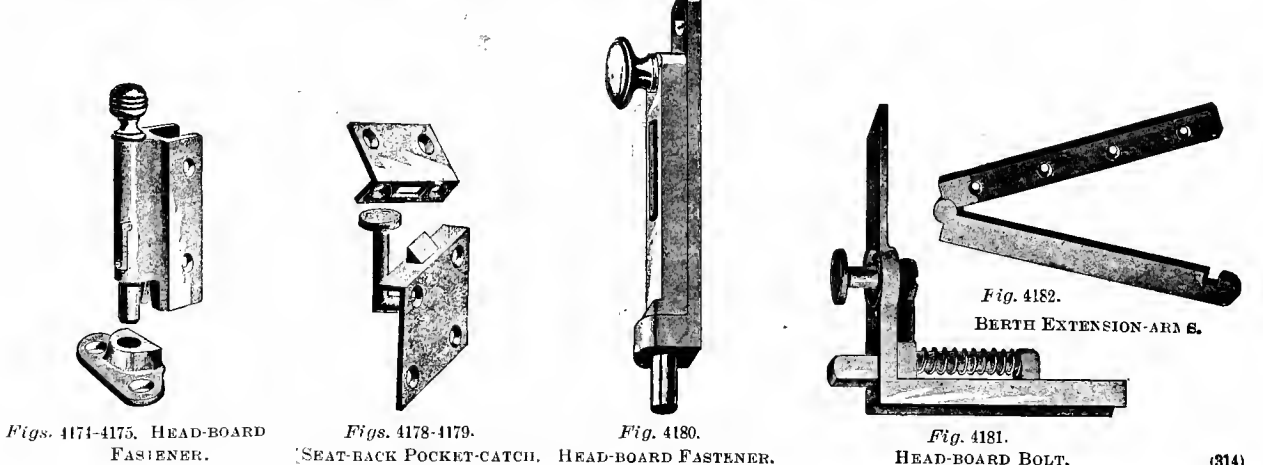

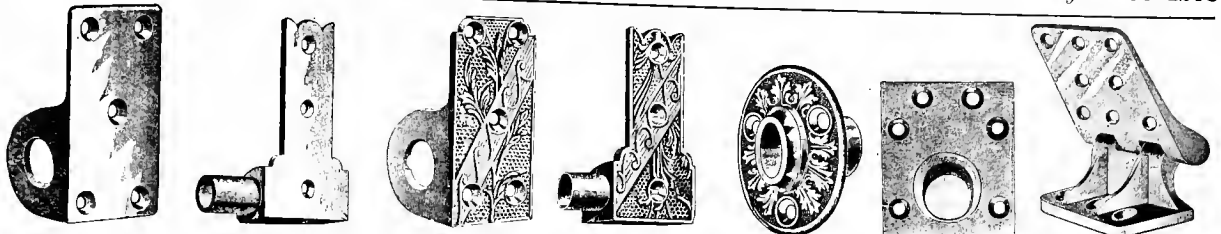

Figs. 4183-4186. BERTH HINGES.



Fig. 4187. BERTH-HINGE PLATE

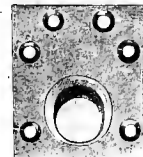

Fig. 4188. BERTH HINGE PIVOT. (Iron.)

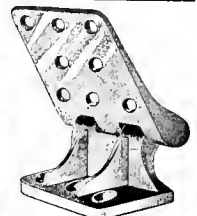

Fig. 4189. FAST BERTH-HINGE.

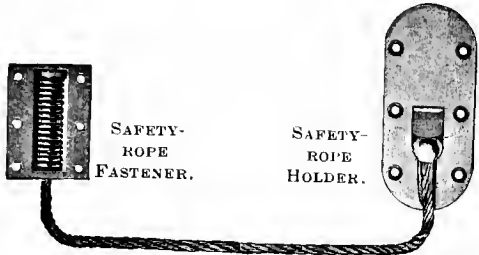

Fig. 4190. BERTH SAFETY-ROPE.

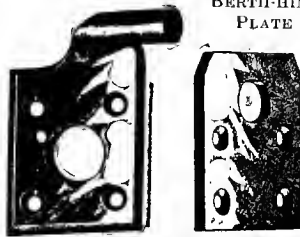

Fig. 4192-4163. BERTH-HINGE AND PLATE.

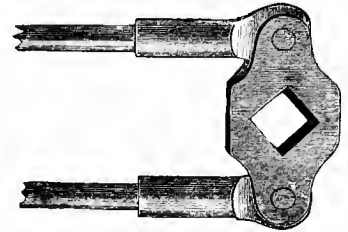
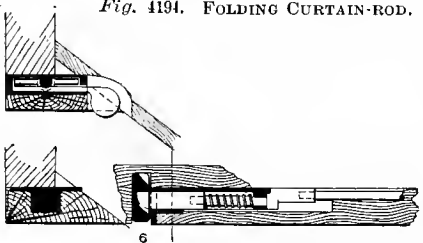

Fig. 4191. BERTH-LOCK RODS.



Fig. 4194. FOLDING CURTAIN-ROD.



Figs. 4195-4196. Sections of Berth-latch.

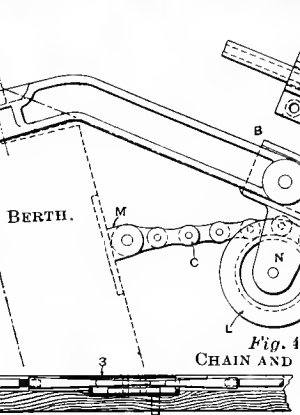

Fig. 4198. CHAIN AND PULLEY.

Letters and Numbers refer to List of Names with Figs. 4233-4258.

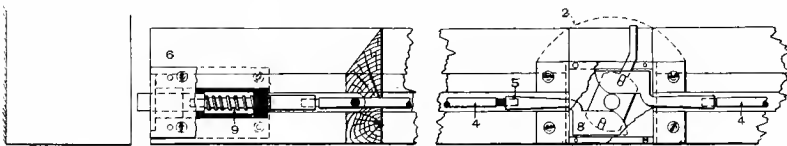

Fig. 4197. Sectional Elevation. BERTH LATCH. PULLMAN'S PALACE CAR COMPANY.

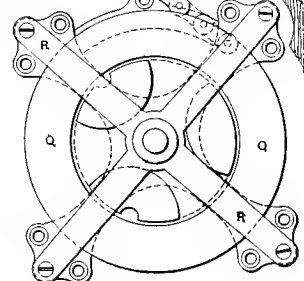

Fig. 4199. BERTH-SPRING.

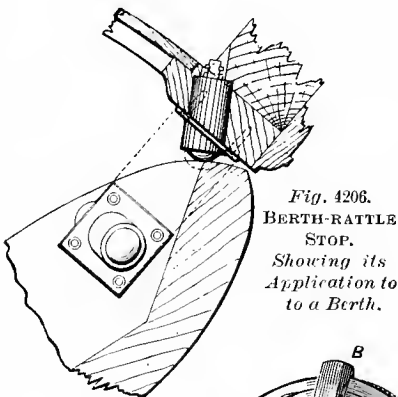
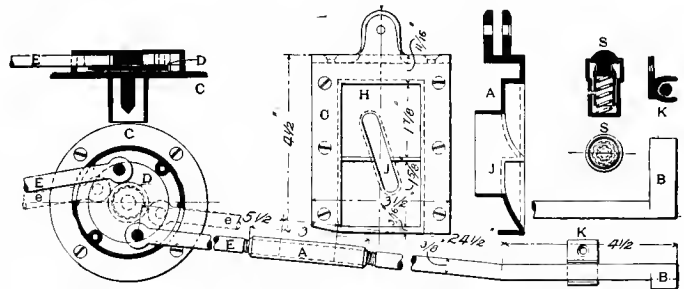

Fig. 4206. BERTH-RATTLE STOP. Showing its Application to a Berth.



Figs. 4200-4205. Center and End Views. BERTH-LOCK. PULLMAN'S PALACE CAR COMPANY.

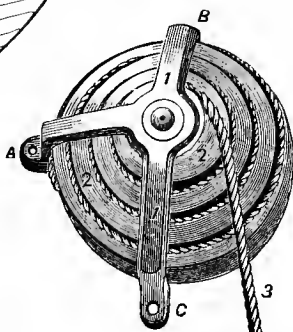

Fig. 4207. BERTH-SPRING-PULLEY.

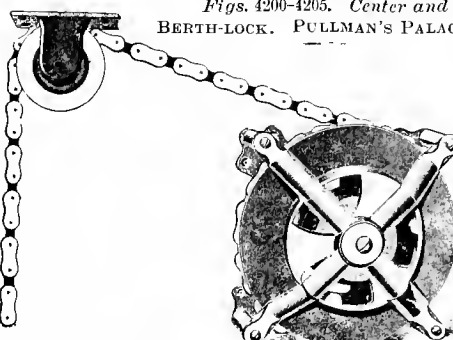

Fig. 4208. BERTH-SPRING-PULLEY, CHAIN AND OVERHEAD PULLEY.



Fig. 4209.

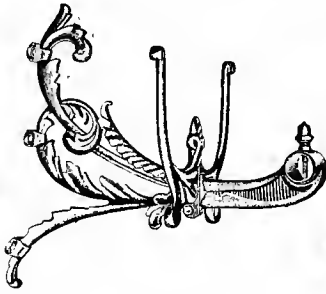

Fig. 4210.

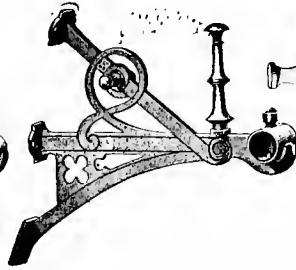

Fig. 4211.

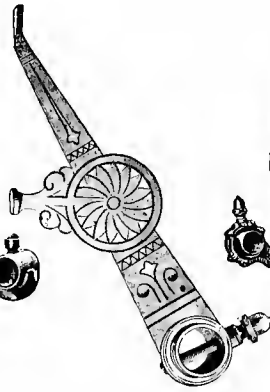

Fig. 4212.



Fig. 4213.

BERTH CURTAIN-ROD BRACKETS.

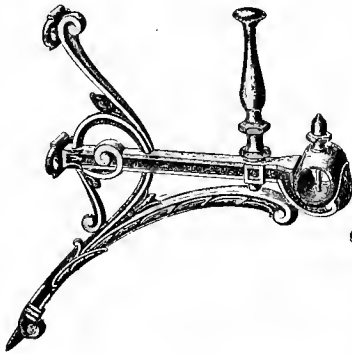

Fig. 4214.



Fig. 4215.

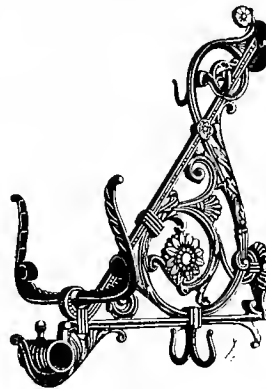

Fig. 4216.

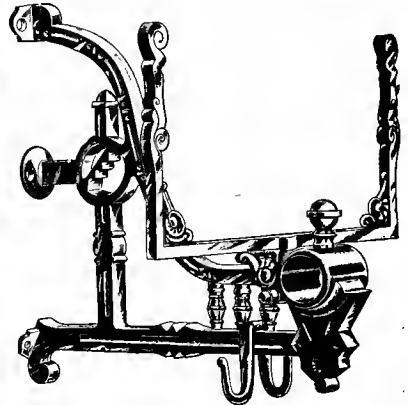
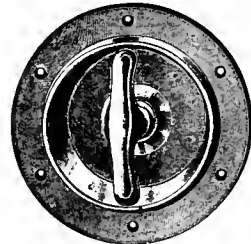

Fig. 4217.

BERTH CURTAIN-ROD BRACKETS.



Fig. 4218.
BERTH-LATCH
HANDLE.



Figs. 4219-4220. BERTH-LATCH HANDLES.

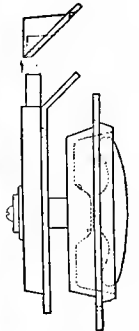

Fig. 4221.
SECTION OF
LOCK-
HANDLE.



Fig. 4222. BERTH-LATCH HANDLE.

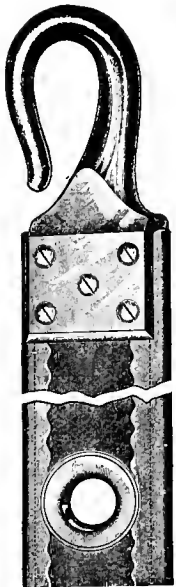

Fig. 4223.
UPPER-BERTH SAFETY-
STRAP AND HOOK.



Fig. 4224.
UPPER-BERTH
SAFETY-ROPE
HANGER.



Fig. 4225.
BERTH CURTAIN-HOOK.



Fig. 4226.
BERTH CURTAIN-HOOK. BERTH SAFETY ROPE-HOOK.

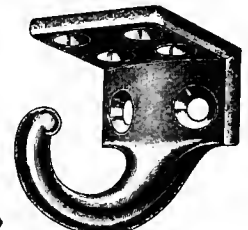
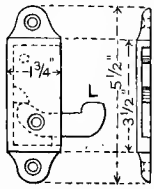

Fig. 4227.



Figs. 4228-4232. BERTH NUMBERS.



Figs. 4259-4260. UPPER-BERTH REST. For leaving upper berth partially open.

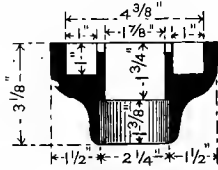
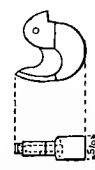

Fig. 4234. Section.



Fig. 4262. END BERTH-REST.



Figs. 4265-4266. HOOK FOR BERTH-CATCH.

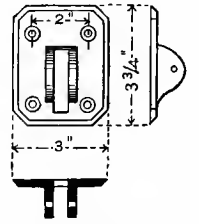

Figs. 4267-4269. BERTH-CATCH.

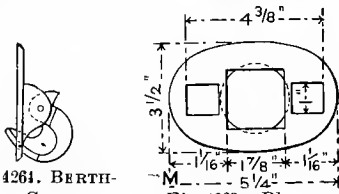

Fig. 4264. BERTH-CATCH COMPLETE.

Fig. 4263. Plan.

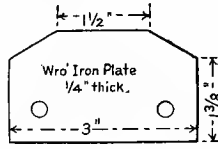
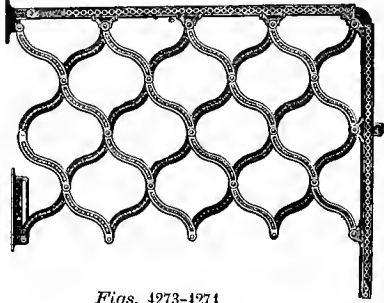
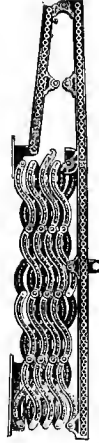

Fig. 4270. STOP-BAR PLATE. To support Stop-bar.

FURNISHINGS FOR A BERTH OF AN EMIGRANT SLEEPING-CAR.



Figs. 4273-4274. SMOKING-ROOM GATE.



Fig. 4275. MATCH-BOX HOLDER.

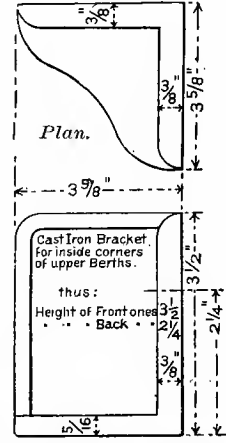

Fig. 4271. Elevation, BERTH CORNER-BRACKET.

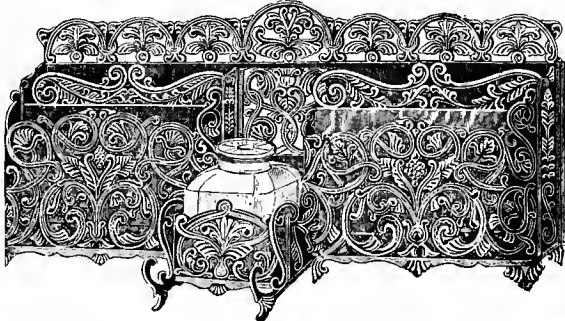

Fig. 4276. PAPER, ENVELOPE AND INK RACK.



Fig. 4277. CIGAR AND ASH RECEIVER.

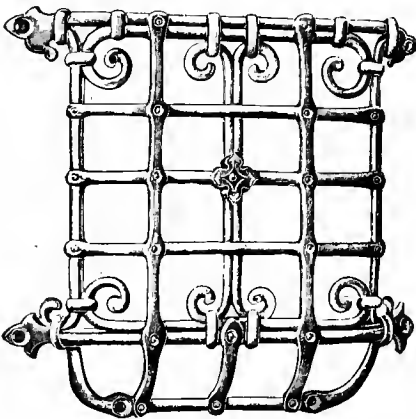
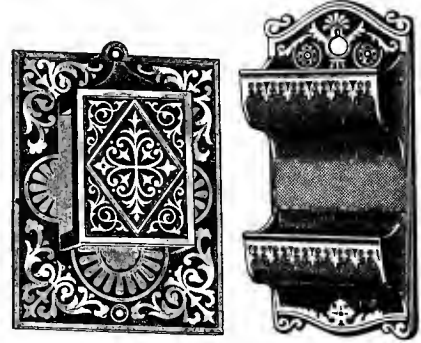

Fig. 4278. TELEGRAPH-BLANK RACK.



Fig. 4279. PEN-RACK.



Figs. 4280-4281. MATCH-BOX HOLDER. MATCH-SAFE.

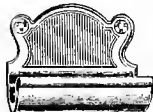

Fig. 4282. MATCH-STRIKER AND CIGAR-HOLDER.



Fig. 4283. ASH-RECEIVER.

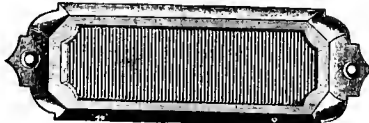

Fig. 4 84. MATCH-STRIKER.

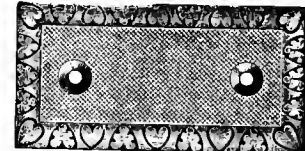
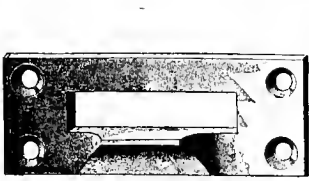

Fig. 4285. MATCH-STRIKER.



Figs. 4286-87. TABLE-HOOK PLATES.



Fig. 4288. TABLE-HOOK.

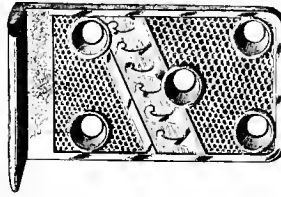

Fig. 4289. TABLE-HOOK.

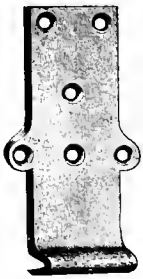

Fig. 4290. TABLE-HOOK.



Fig. 4291. TABLE-LEG HOOK.



Figs. 4292-4293. TABLE-HOLDER AND PLATE.

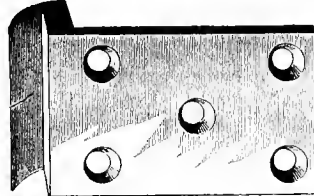

Fig. 4294. TABLE-HOOK.

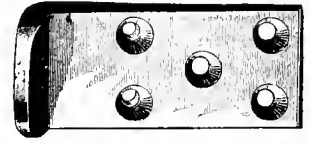

Fig. 4295. TABLE-HOOK.

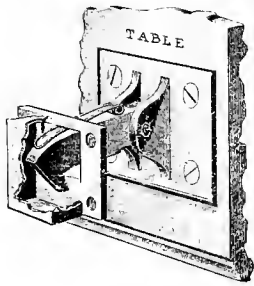
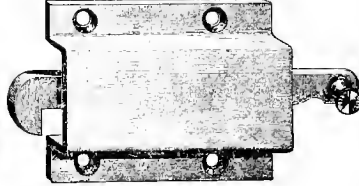

Fig. 4296.



TABLE-FASTENERS.



Figs. 4297-4298.

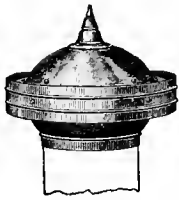

Fig. 4300.

THE GLOBE VENTILATOR.

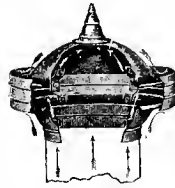

Fig. 4301.

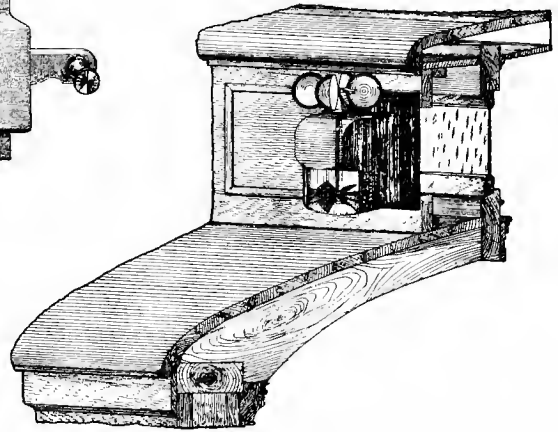

Fig. 4299. THE TORNADO VENTILATOR.

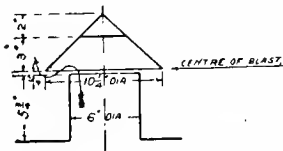

Fig. 4302. THE CONE CAP.

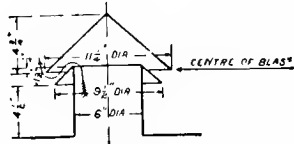

Fig. 4303. THE CONE AND APRON.

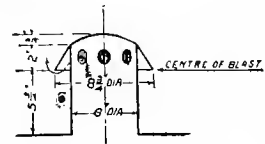

Fig. 4304. THE CANOPY.

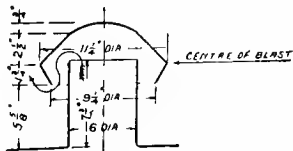

Fig. 4305. THE TORNADO CANOPY.

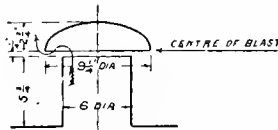

Fig. 4306. THE DISHED CAP.

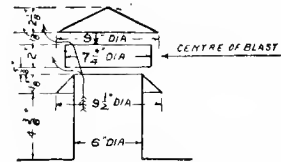

Fig. 4307. THE MOORE.

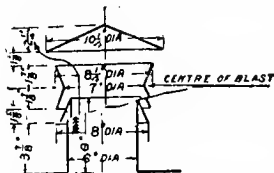

Fig. 4308. THE DUPLEX.

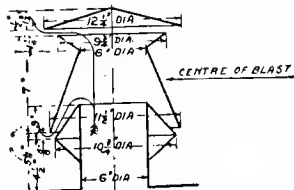

Fig. 4309. THE ROE.
TYPES OF VENTILATORS.

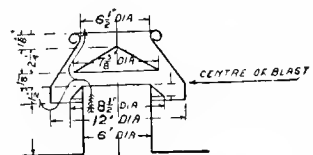

Fig. 4310. THE STASCH.

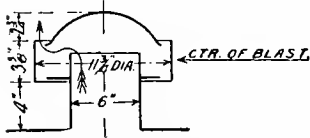

Fig. 4315. THE WORLD.

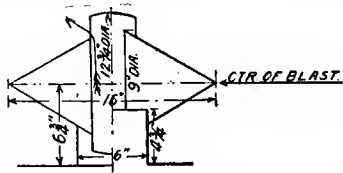

Fig. 4316. THE TORPEDO.

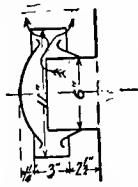

Fig. 4313. THE GLOBE HORIZONTAL.

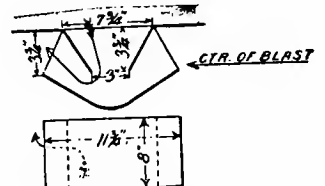

Fig. 4314. THE CREAMER EUREKA.

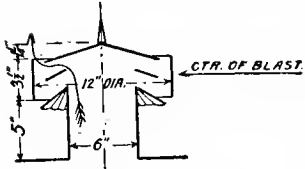

Fig. 4311. THE STAR.

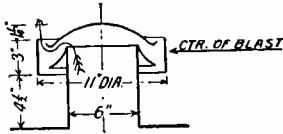

Fig. 4312. THE GLOBE ERECT.

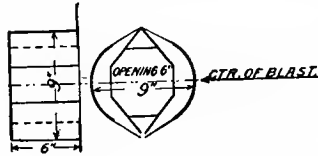

Fig. 4317-17a. THE DEFLECTOR.

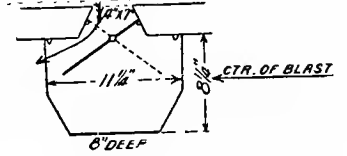

Fig. 4318. THE CREAMER AUTOMATIC.

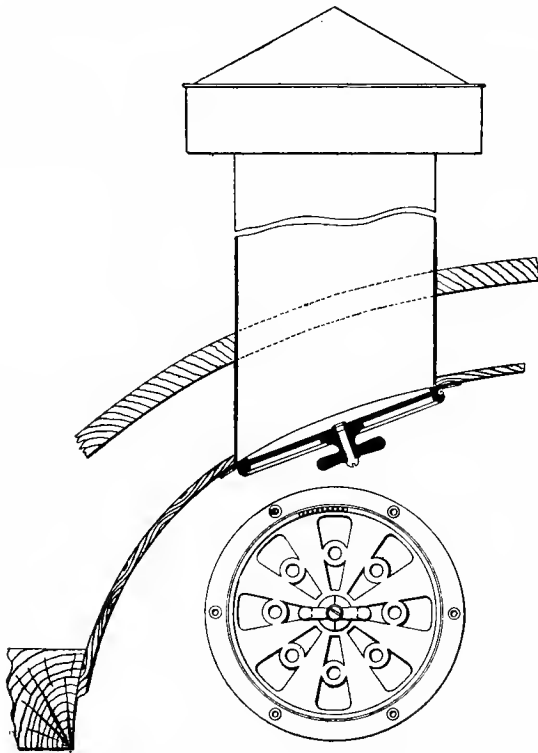
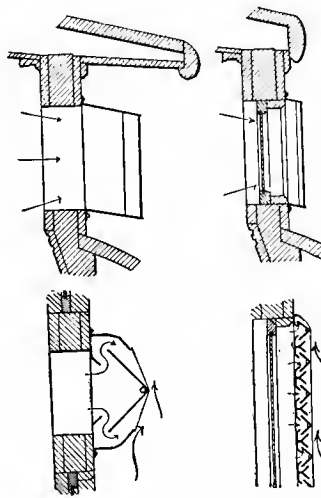
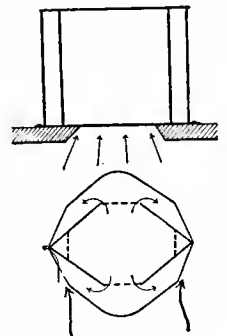

Fig. 4325-5. VENTILATOR FOR SALOONS.



Figs. 4319-20, SMALL DUPLEX DEFLECTOR.

Figs. 4321-22, CONTINUOUS DUPLEX DEFLECTOR.



Figs. 4323-24, DOUBLE-DUPLEX DEFLECTOR (VERTICAL).

THE PANCOAST VENTILATORS (PATENTED).

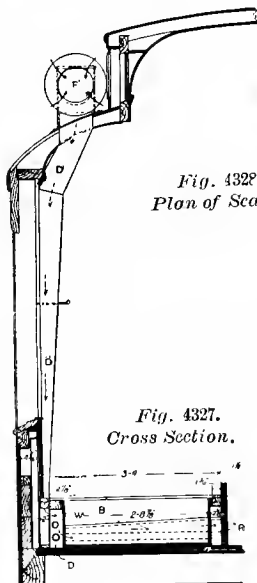

Fig. 4327. Cross Section.

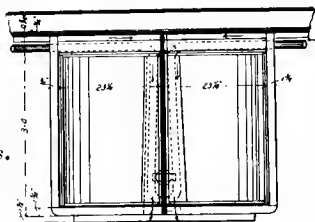

Fig. 4328. Plan of Seats.

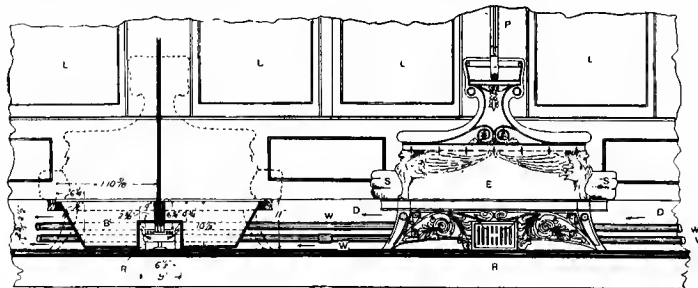

Fig. 4329. Elevation.

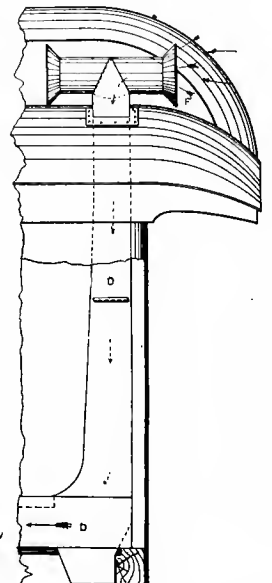

Fig. 4329a. Sectional Elevation.

NAMES OF PARTS. Figs. 4327-29a.

- B. Pillow-box.
- D. Cold-air Duct.
- E. Seat-end.
- F. Wind-scoop or Funnel.
- L. Car Window.
- R. Hot-air Register.
- S. Seat-cushion.
- W. Hot-water Pipes.

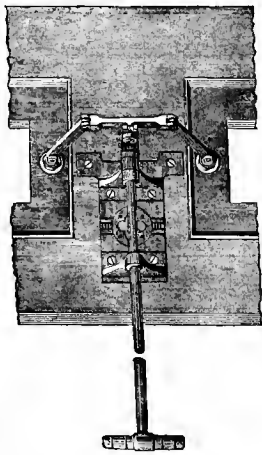

Fig. 4330. Windows Closed.

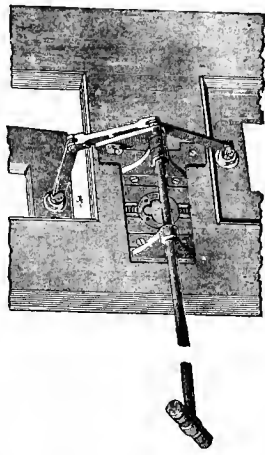

Fig. 4331. One Window Open.
MANSFIELD DECK-SASH OPENER.

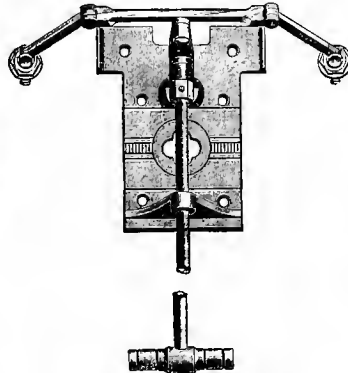
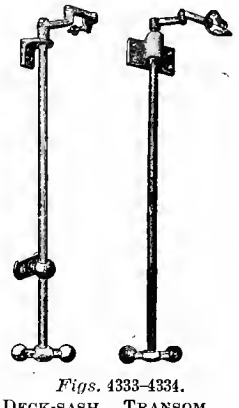

Fig. 4332. Opener Complete.



Figs. 4333-4334.
DECK-SASH OPENER. TRANSOM OPENER.

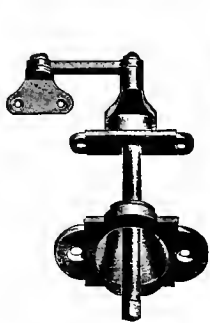

Fig. 4335. Lauder Monitor.

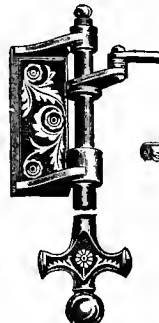

Fig. 4336. Single, Decorated.



Fig. 4337. Single, with Handle.

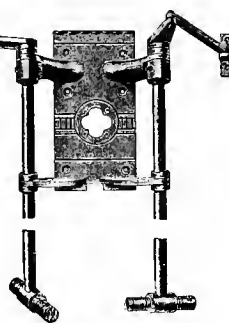

Fig. 4338. Mansfield's Improved.

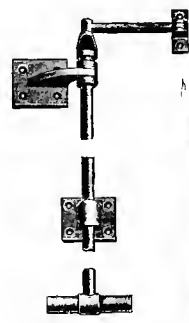
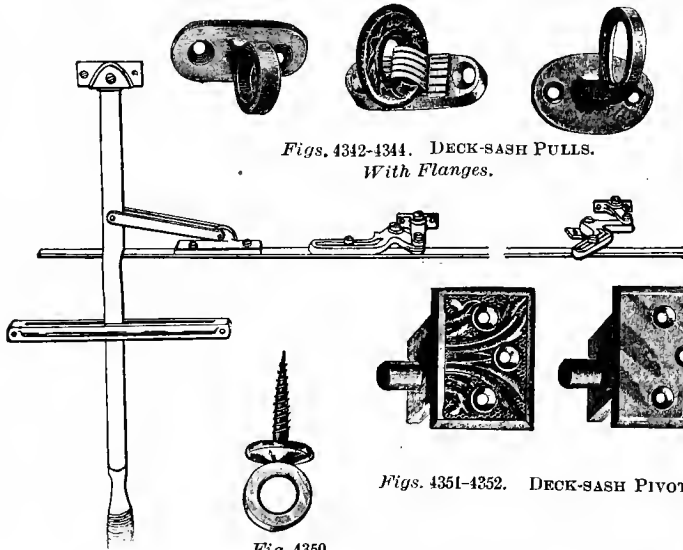

Fig. 4339. Single, Plain.



Figs. 4340-41. Single Key.

DECK-SASH OPENERS.



Figs. 4342-4344. DECK-SASH PULLS.
With Flanges.

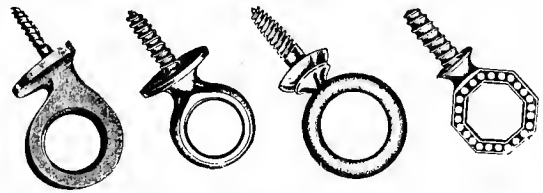

Figs. 4345-4348. DECK-SASH PULLS.
With Screws.

Fig. 4349. CONTINUOUS DECK-SASH OPENER.
With Screw.

With Screw.

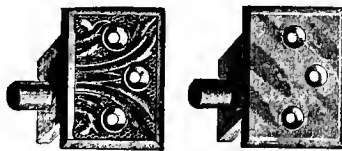

Figs. 4351-4352. DECK-SASH PIVOTS.

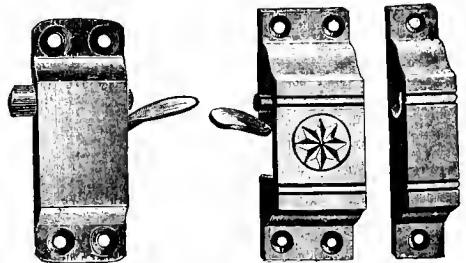

Figs. 4353-4355. DECK-SASH PIVOTS.

Fig. 4350. PULL.

With Screw.

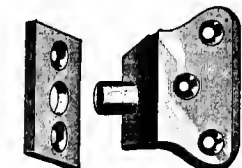
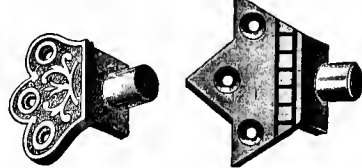
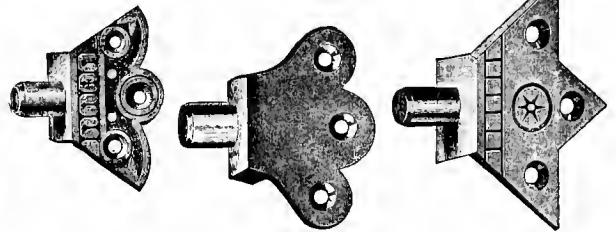

Fig. 4356.



Figs. 4357-4359. DECK-SASH PIVOTS AND PLATE.



Figs. 4360-4362. DECK-SASH PIVOTS.

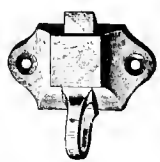
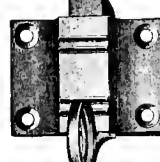
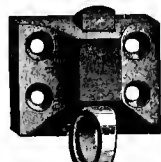
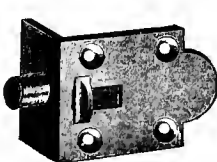

(321) Figs. 4363-4364. DECK-SASH PIVOTS.

Figs. 4365-4368. DECK-SASH AND TRANSOM CATCHES.

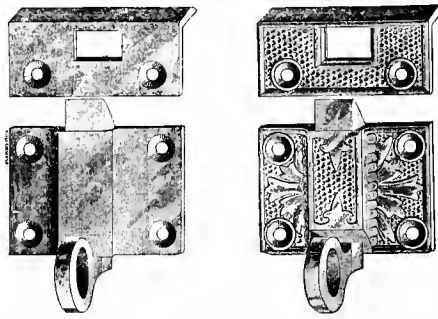

Figs. 4369-4372.
DECK-SASH CATCHES.

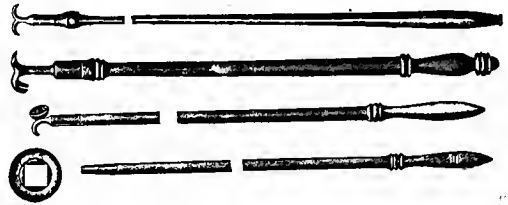

Figs. 4376-4380.
PULL-HOOKS OR DECK-SASH OPENERS.



Fig. 4373.

Fig. 4374.
DECK-SASH CATCHES.

Fig. 4375.

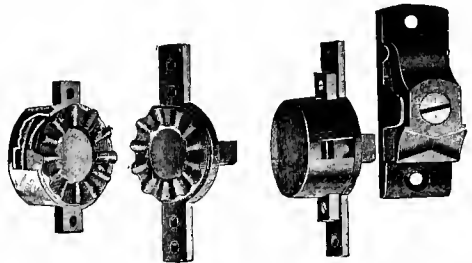

Figs. 4385-4388.
Lower Ratchet-plate and Ratchet-spring.
Upper Ratchet-plate.

Figs. 4387-4388.
Ratchet-clamp.
pivot.

MORGAN AUTOMATIC DECK-SASH PIVOT AND CLAMP.

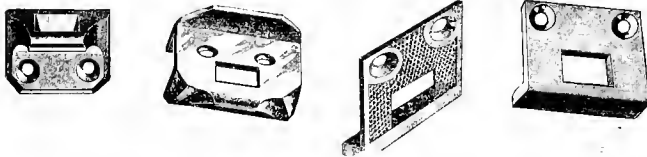

Fig. 4381.

Fig. 4382.

Fig. 4383.

Fig. 4384.

DECK-SASH CATCH-PLATES OR STRIKE-PLATES.

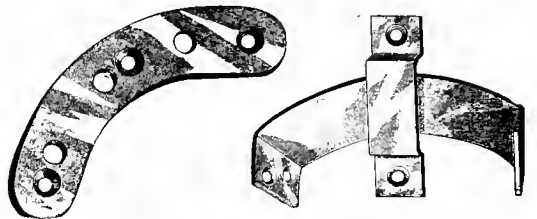

Fig. 4389. DECK-SASH
CIRCLE-PLATE.

Fig. 4390. DECK-SASH
QUADRANT AND CLIP.

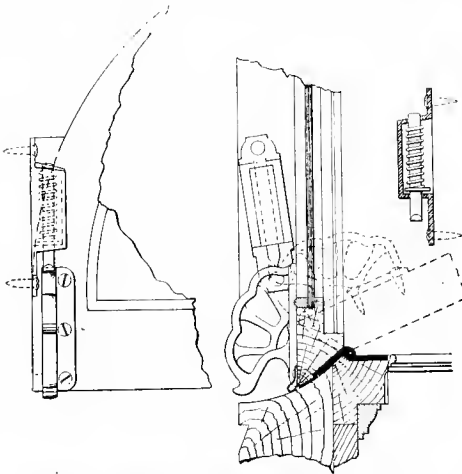

Fig. 4391-4393. Sectional Elevations.
PULLMAN DECK-SASH PIVOT AND RATCHET-CATCH.



Fig. 4394.

DECK-SASH SOCKET AND SPRING,
AND RATCHET-CATCH (half size).

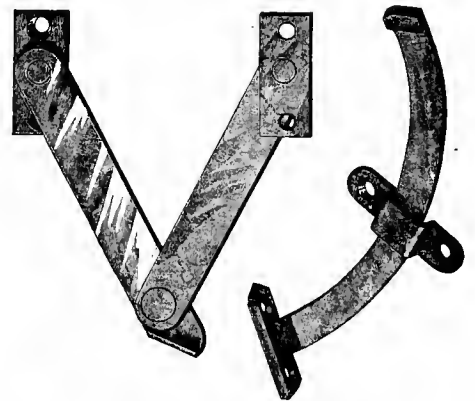

Fig. 4395. DECK-SASH
STOP-HINGE.

Fig. 4396. DECK-SASH
QUADRANT AND CLIP.

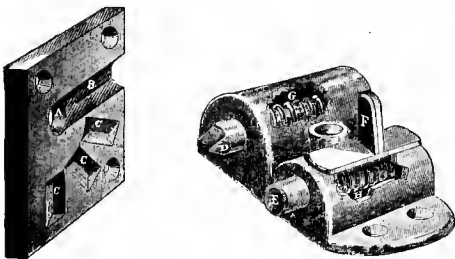

Fig. 4397.
Ratchet-plate.

Fig. 4398.
Pivot and Ratchet-bolt.
"MONITOR" DECK-SASH PIVOT AND RATCHET-
CATCH.



Fig. 4399.
DECK-SASH DOUBLE-RATCHET
AND RATCHET-PLATE (Left hand).



Fig. 4400.

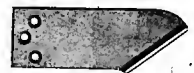

Fig. 4401. TRANSOM-SASH STOP.

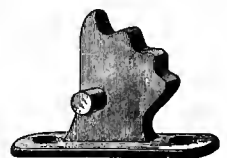
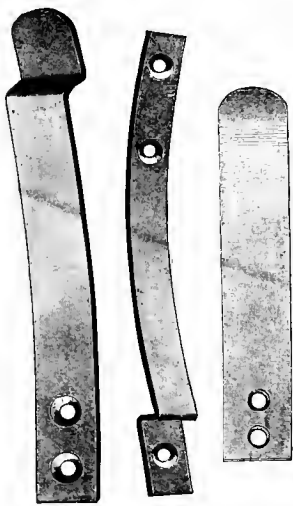

Fig. 4402.
DECK-SASH PIVOT AND RATCHET.



Figs. 4403-4405.
SASH AND BLIND SPRINGS

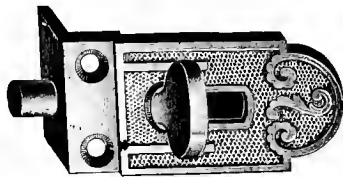
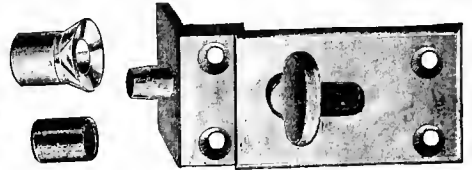

Fig. 4403.
BLIND BOLT.



Figs. 4407-4408.
BLIND-BOLT BUSHING.

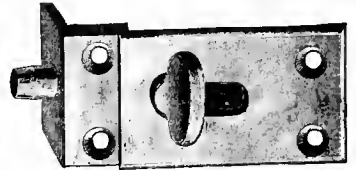

Fig. 4409.
BLIND BOLT.



Fig. 4420.
LOWER WINDOW-BLIND PULL OR LIFT.

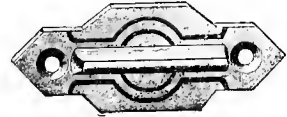

Fig. 4421.
UPPER WINDOW-BLIND PULL OR LIFT.

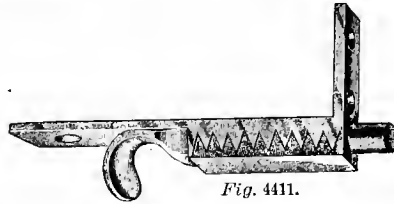

Fig. 4411.

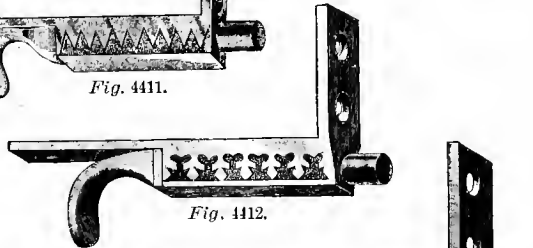

Fig. 4412.

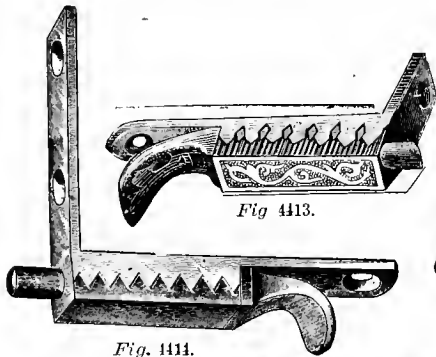

Fig. 4414.

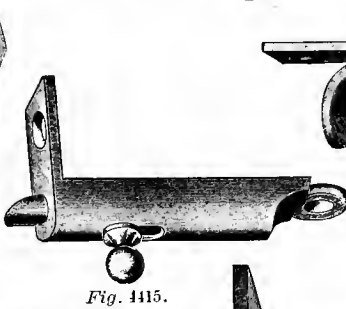

Fig. 4415.

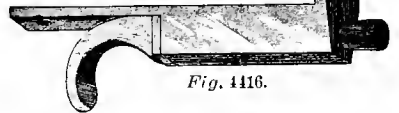

Fig. 4416.



Fig. 4417.



Fig. 4418.

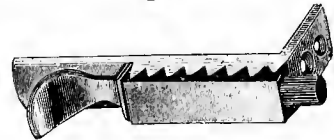
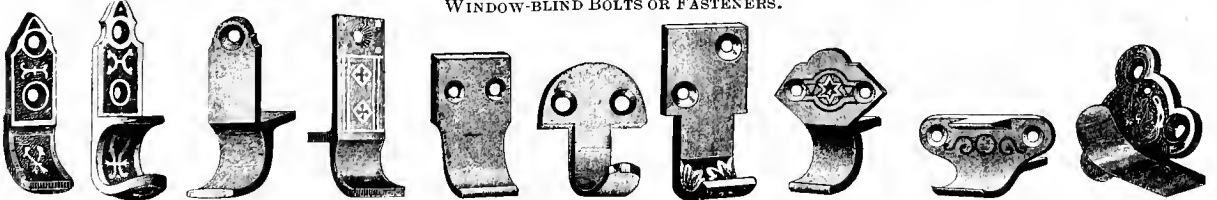
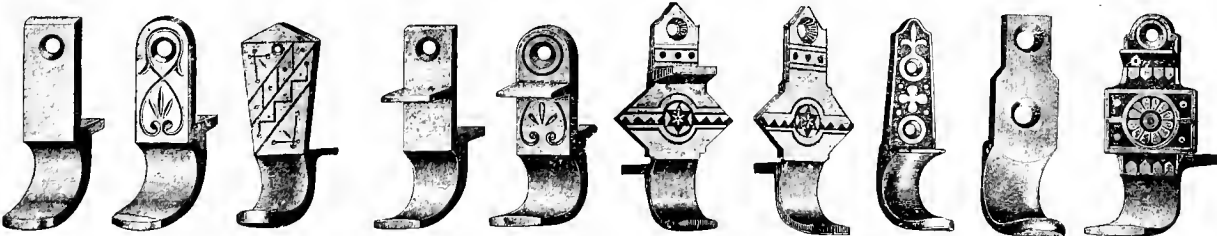

Fig. 4419.

WINDOW-BLIND BOLTS OR FASTENERS.



Figs. 4422-4434. WINDOW-BLIND PULLS OR LIFTS.



Figs. 4432-4441. UPPER AND LOWER WINDOW-BLIND PULLS OR LIFTS.



Figs. 4442-4449. UPPER AND LOWER WINDOW-BLIND PULLS OR LIFTS.
A Lower Window-blind Pull has a projecting Flange to support the Upper-blind.

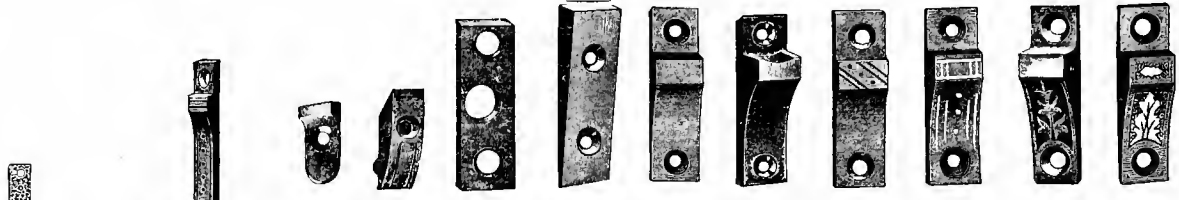

Figs. 4455-4464. SASH AND BLIND LOCK-STOPS.

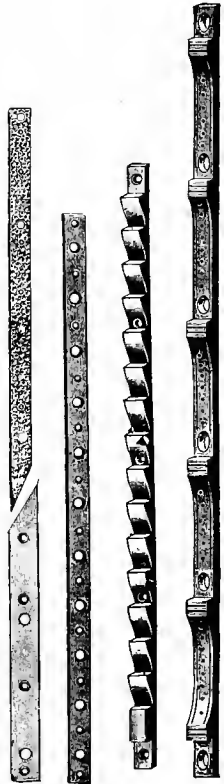

Figs. 4450-4454.
END-DOOR RATCHET SASH
SASH-BOLT AND BLIND
PLATES. LOCK-STOPS.

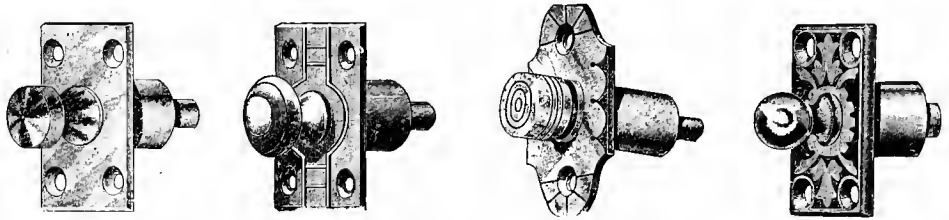

Figs. 4465-4468. END-DOOR-SASH BOLTS.

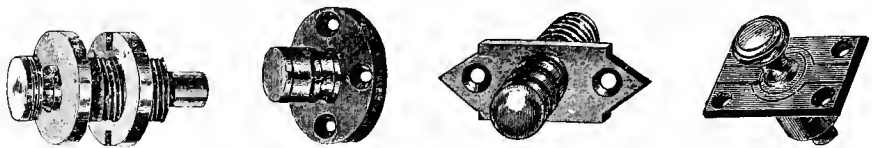

Fig. 4469. END-DOOR-SASH BOLT.

Fig. 4470. END-DOOR-SASH LIFT.

Fig. 4471-4472.
END-DOOR SASH-BOLTS.



Figs. 4473-4474. SASH-BARS.

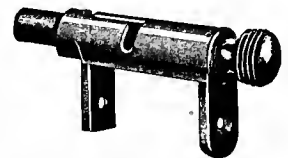

Fig. 4475. PARADISE SASH-LOCK

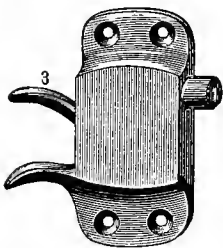

Fig. 4476.
SASH-LOCK.

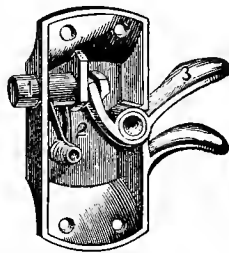
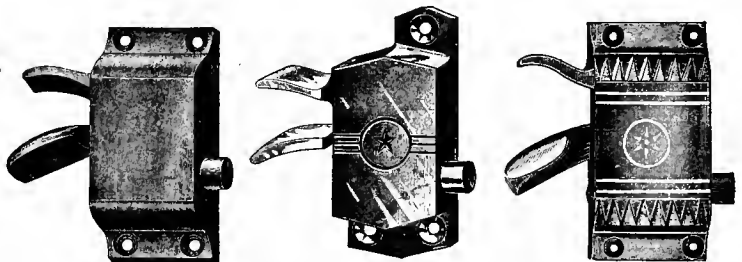
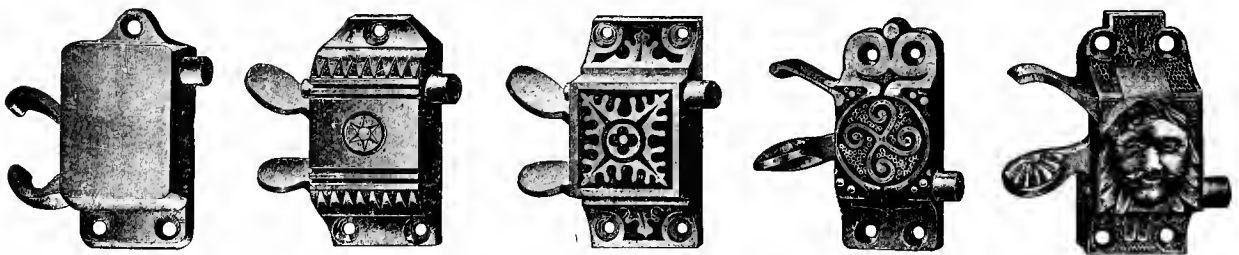

Fig. 4477. Back View.
SASH-LOCK.



Figs. 4478-4480. WINDOW SASH-LOCKS.



Figs. 4481-4485. WINDOW SASH-LOCKS.



Figs. 4486-4487.

WINDOW SASH-LOCKS.

Figs. 4488-4490.

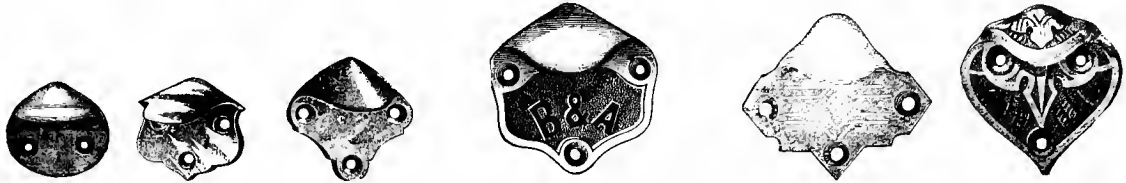

Figs. 4491-4496. WINDOW-SASH LIFTS, CONE TOP.



Figs. 4497-4501. WINDOW-SASH LIFTS, CONE AND STRAIGHT TOP.

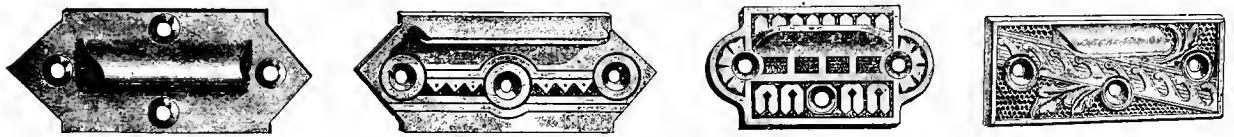

Figs. 4502-4505. WINDOW-SASH LIFTS, STRAIGHT TOP.

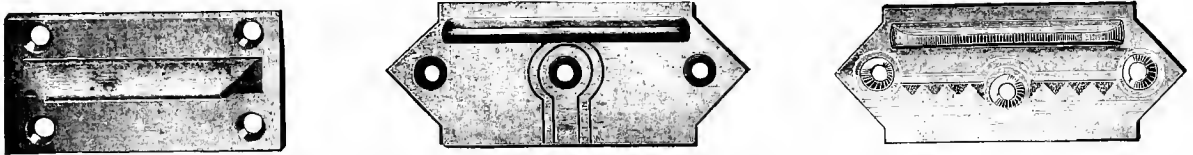

Figs. 4506-4508. WINDOW-SASH LIFTS, STRAIGHT TOP.

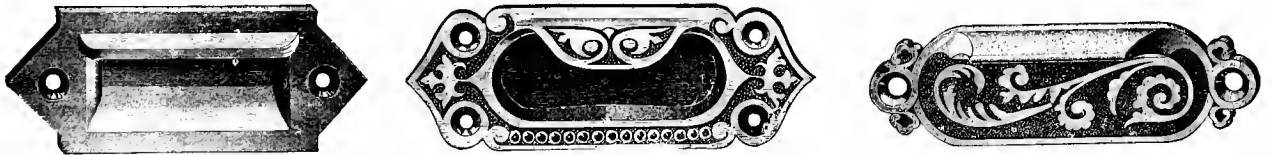

WINDOW-SASH LIFTS, MORTISE.

WINDOW-SASH-LIFT,

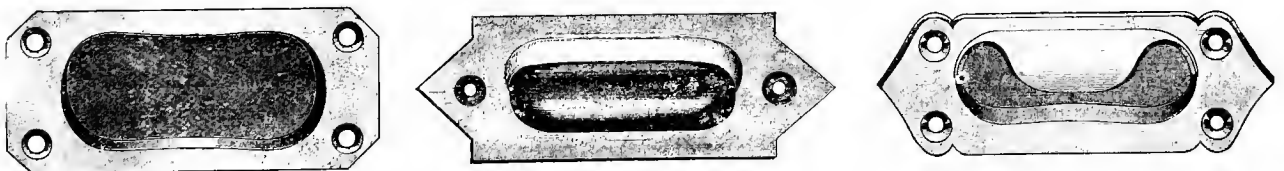

Figs. 4512-4514. WINDOW-SASH LIFTS, MORTISE.

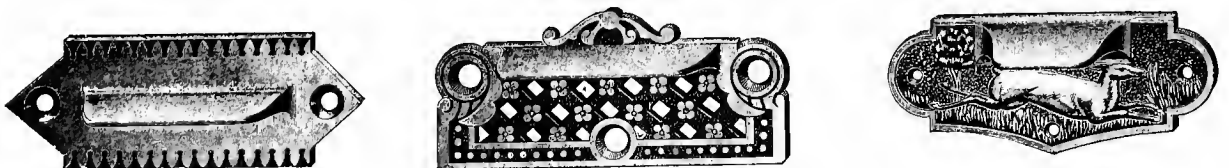

Figs. 4515-4517. WINDOW-SASH LIFTS, STRAIGHT TOP.

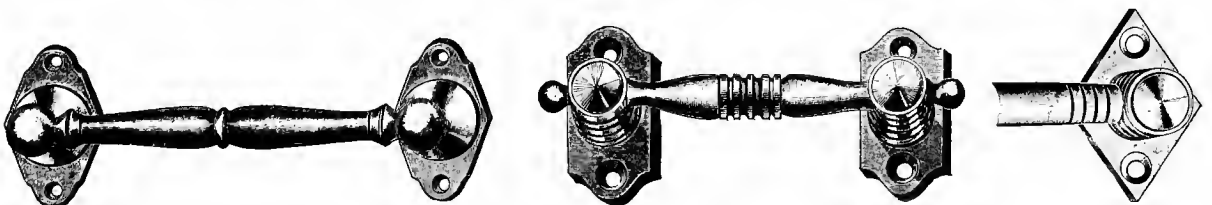

Figs. 4518-4520. WINDOW-SASH LIFTS, BAR PATTERN.

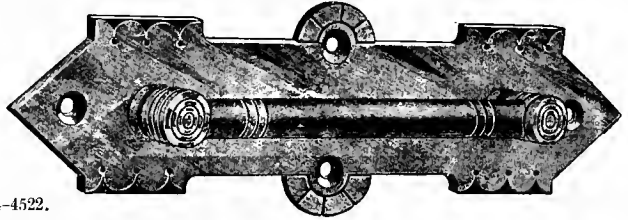

Figs. 4521-4522. WINDOW-SASH LIFTS, BAR PATTERN.

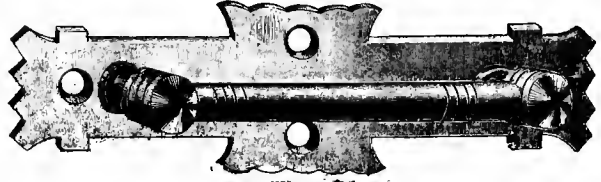
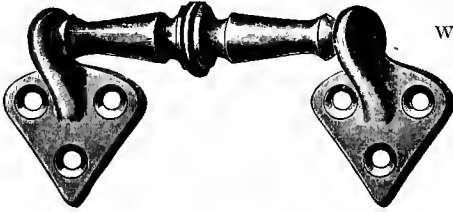

Figs. 4523-4524. WINDOW-SASH LIFTS, BAR PATTERN.

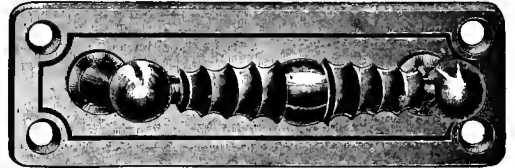
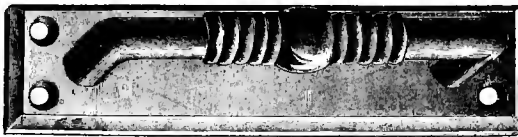

Figs. 4525-4526. WINDOW-SASH LIFTS, BAR PATTERN.

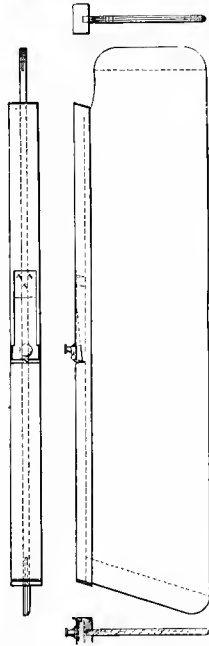

Figs. 4527-4530. Elevations and Plans. WINDOW DUST-GUARD OR DEFLECTOR.

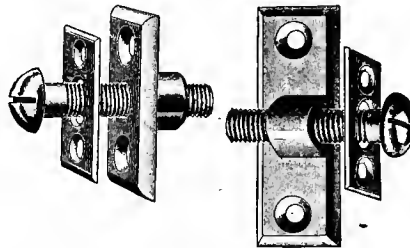

Figs. 4531-4532. STORM-SASH FASTENER.

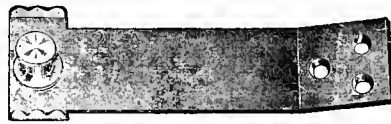

Fig. 4533. DUST-GUARD SPRING-HOLDER.



Fig. 4534. For the Upper Sash of Windows.

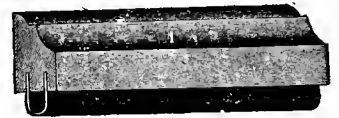

Fig. 4535. For the Lower Sash of Windows.

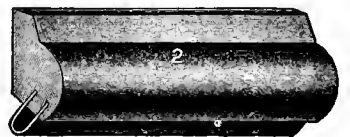

Fig. 4536. For the Center of Windows.

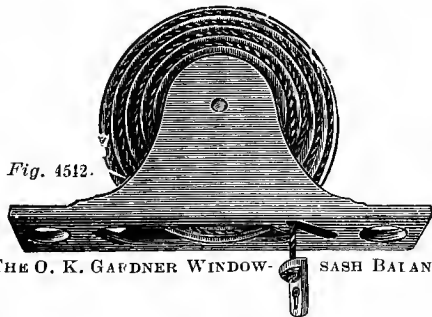

Fig. 4512. THE O. K. GARDNER WINDOW-SASH BALANCE.

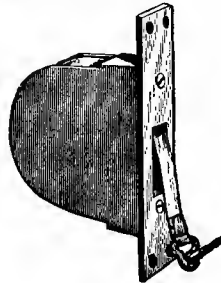

Fig. 4513. THE CALDWELL WINDOW-SASH BALANCE.

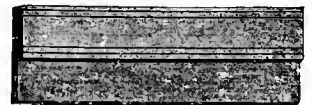

Fig. 4537. Rubber Weather Strip. BOSELEY'S EXCELSIOR WEATHER STRIPS.



Figs. 4538-4539. For Narrow Parting Strips of Windows and Sides of Doors. BOSELEY'S METALLIC WEATHER STRIPS.



Figs. 4540-4541. For Windows and Sides of Doors. COSPER'S METALLIC WEATHER STRIPS.

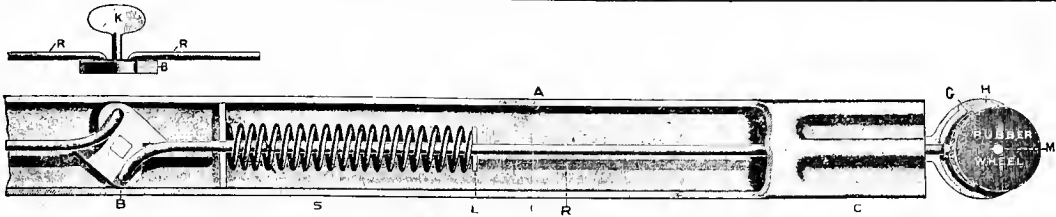

Figs. 4544-4545. DAVIS SHADE-HOLDING DEVICE.

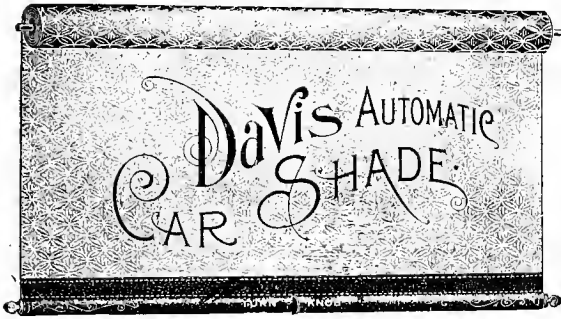

Fig. 4546.

DAVIS AUTOMATIC CAR-SHADES.
With Patent Automatic Shade-holding Device.

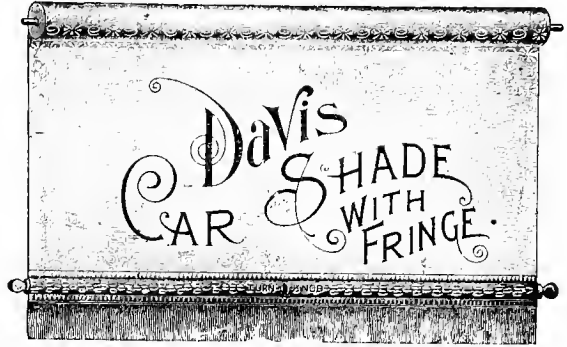

Fig. 4547.

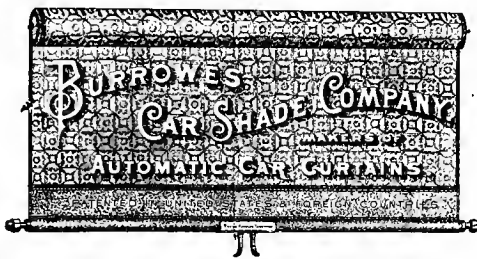

Fig. 4548.

BURROWES' AUTOMATIC CAR-SHADE.
With Patent Automatic Shade-holding Device.

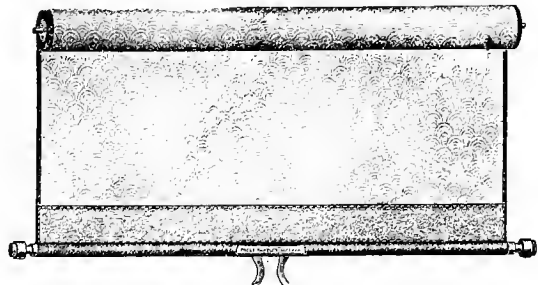

Fig. 4549.

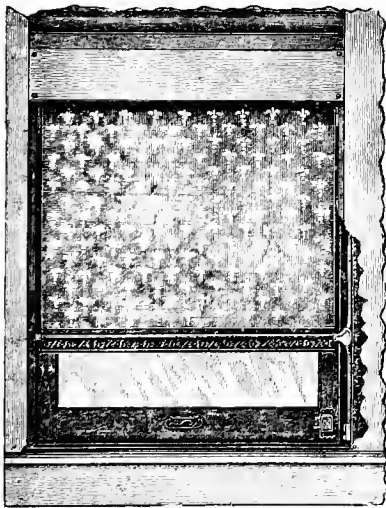

Fig. 4550.

ACME AUTOMATIC WINDOW-SHADE.
(One Guide Exposed)
ADAMS & WESTLAKE COMPANY.



Fig. 4551. LAMBRÉQUIN AND SHADES
FOR PARLOR-CAR.
HALE & KILBURN MFG. CO.

NAMES OF PARTS. Figs. 4544-4545.

- A. Steel Tube, Oval Cross-section.
- B. Cam or Eccentric.
- C. Corrugated End.
- G. Brake.
- H. Brass-tip to Carry Rubber Wheel.
- K. Thumb-latch.
- L. Rod-bearing for Spring.
- M. Wheel-axle.
- R. Steel Rod.
- S. Spring.

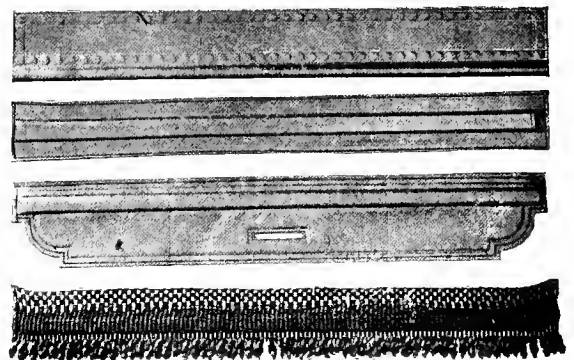
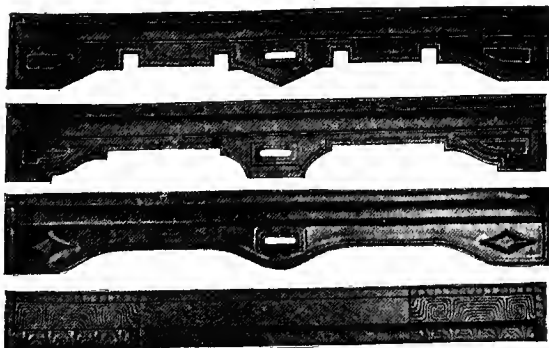

Figs. 4552-4553. LEATHER AND FRINGE SHADE BOTTOMS.
In all Colors and Designs to match Tapestry.

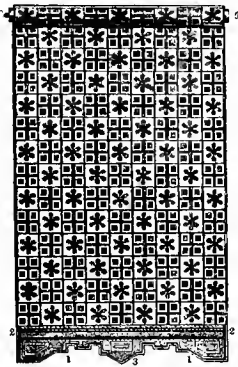

Fig. 4565.

WINDOW-SHADE OR CURTAIN.

1. Window-shade Leather.
2. Window-shade Rod.
3. Window-shade Eyelet.
4. Window-shade Roller.
5. Window-shade Roller-bearings.

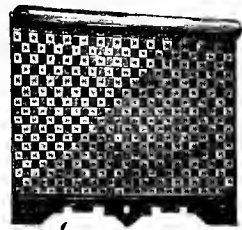

Fig. 4561.

COACH WINDOW-CURTAIN.

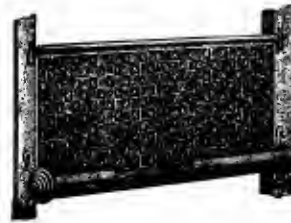

Fig. 4562.

BUFFET-CURTAIN AND BRASS CASING.

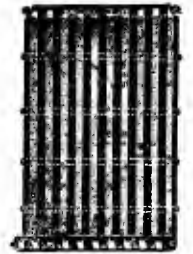
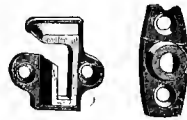

Fig. 4563.

CURTAIN FOR OPEN STREET-CARS.



Figs. 4567-4568.

McKAY'S CURTAIN-BRACKETS,
No. 2.
(Half size.)

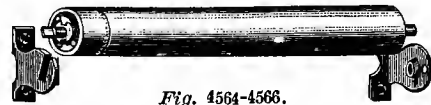
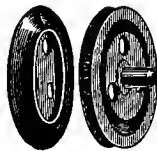
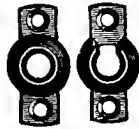

Fig. 4564-4566.

HARTSHORN SHADE-ROLLER AND BRACKETS,
SHOWING CENTRIFUGAL PAWLS.
(The McKay shade-roller is somewhat similar, but uses
a cam instead of a pawl.)



Figs. 4569-4570.
WINDOW-CURTAIN
PULLEYS.



Figs. 4571-4572.
WINDOW-CURTAIN
ROLLER BEARINGS.
(Old style.)



Fig. 4572.
WINDOW-CURTAIN
BRACKET.



Figs. 4574-4575.
McKAY'S CURTAIN BRACKETS, No. 1.
(Half size.)

CAR TRUCKS.

COMPLETE LIST OF NAMES OF THE PARTS OF FREIGHT-CAR TRUCKS. Figs. 4576-4805.

Names of parts in Roman type are special to the miscellaneous and exceptional types of freight-car trucks shown on the following pages. Those in italics only are parts belonging to the Diamond type of truck, which is now the almost universal standard.

Numbers which are omitted from this list are for parts special to passenger-car trucks. Figs. 4806-4966.

- | | | |
|--------------------------------------|---|---|
| 1. Wheel. | 37. Bolster Guide-bars or Truck-column. | 87. Brake-hanger Carrier. |
| 2. Axle. | 38. Bolster Guide-block. | 88. Brake-beam Safety-chain. |
| 3. Journal-box. | 43. Spring-plank. | 89. Brake Safety-chain Eye-bolt. |
| 4. Journal-box Lid. | 44. Spring-plank Bearing. | 90. Brake-beam Safety-strap. |
| 5. Pedestal. | 46. Swing-hangers. | 91. Release-spring. |
| 6. Pedestal Tie-bar. | 47. Upper Swing-hanger Pivot. | 92. Brake-lever. |
| 9. Continuous Truck-frame. | 48. Lower Swing-hanger Pivot. | 93. Brake-lever Fulcrum. |
| 10. Wheel-piece. | 49. Swing-hanger Pivot-bearing. | 94. Brake-lever Guide. |
| 14. Arch-bar. | 51. Safety-beam. | 95. Brake-lever Stop. |
| 15. Inverted Arch-bar. | 55. Axle Safety-strap. | 96. Brake-lever Sheave. |
| 16. Auxiliary Arch-bar. | 57. Safety-beam Truss-rod. | 97. Lower Brake-rod. |
| 17. End-piece. | 58. Safety-beam Truss-rod Bearing. | 98. Brake-shoe. |
| 20. Transom. | 61. Truck Side-bearing. | 107. Body Center-plate. |
| 24. Transom Truss-rod. | 63. Truck Center-plate. | 108. Journal-box Bolts. |
| 25. Transom Truss-block. | 64. Center-plate Block. | 109. Column-bolt. |
| 26. Transom Truss-rod Washer. | 74. Bolster Spring-seat. | 111. Journal. |
| 27. Transom Chafing-plate. | 75. Bolster Spring-cap. | 112. Journal Bearing. |
| 28. Transom-casting. | 78. Journal-box Spring. | 113. Journal-box Wedge. |
| 29. Transom-pillar. | 80. Bolster-spring. | 114. Stop-plate. |
| 30. Truck-bolster. | 82. Brake-block. | 115. Dust-guard. |
| 31. Truck-bolster Truss-rod. | 83. Brake-head. | 121. Brake-beam Adjusting-hanger Carrier. |
| 32. Truck-bolster Truss-block. | 84. Brake-beam. | 122. Brake-beam Adjusting-hanger. |
| 34. Truck-bolster Truss-rod Bearing. | 85. Brake-beam Eye-bolt. | 123. Brake-beam Adjusting-hanger Clip. |
| 35. Truck-bolster Truss-rod Washer. | 86. Brake-hanger. | |
| 36. Truck-bolster Chafing-plate. | | |

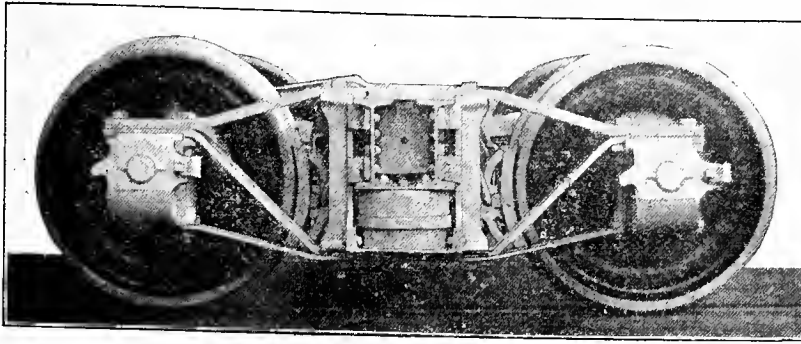

Fig. 4576. Side View.
FREIGHT-CAR TRUCK. HARVEY STEEL CAR & REPAIR WORKS.

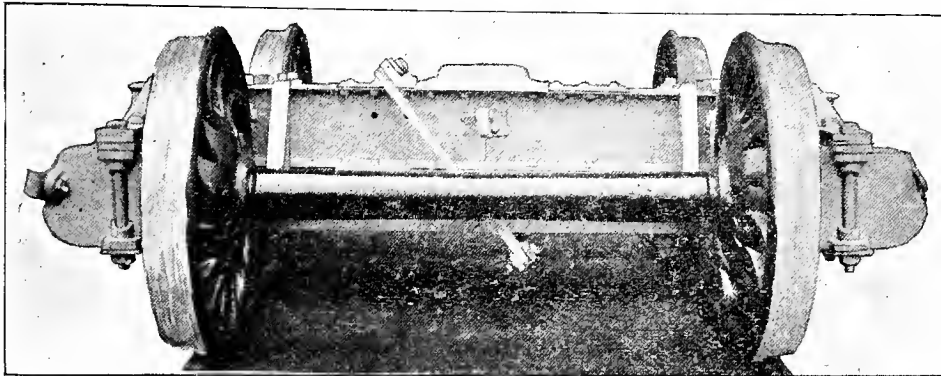

Fig. 4577. End View.
FREIGHT-CAR TRUCK. HARVEY STEEL CAR & REPAIR WORKS, HARVEY, ILL.

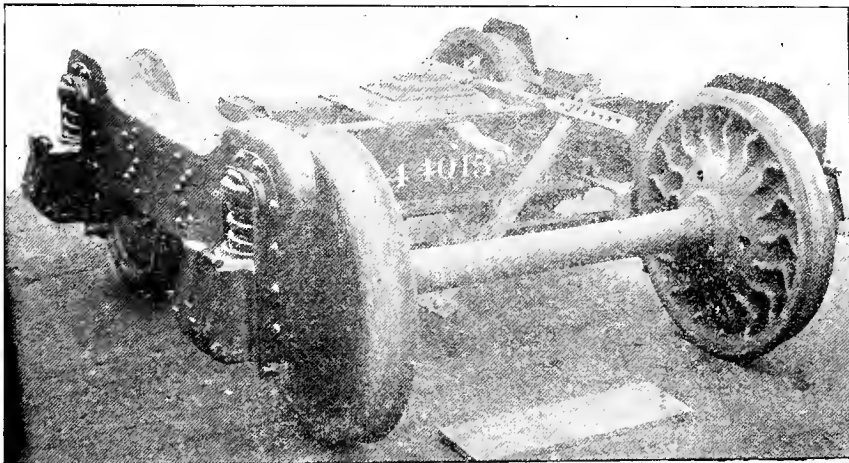

Fig. 4578. Perspective View.
THE FOX SOLID-PRESSED-STEEL TRUCK.
60,000-lb. M. C. B. Wheels, Axles and Bearings.

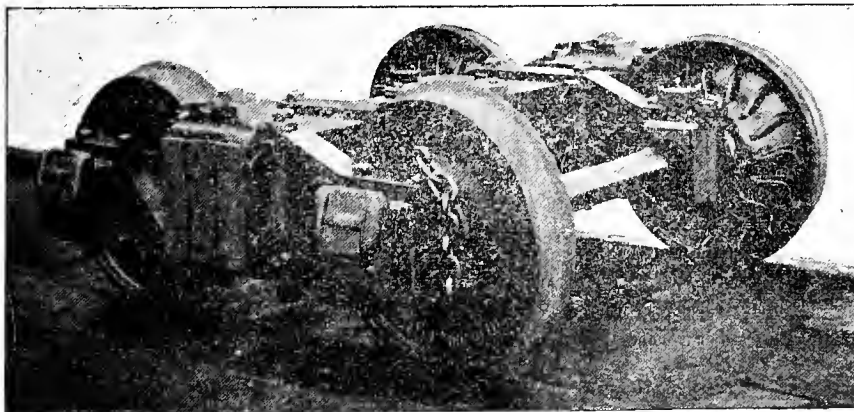

Fig. 4579. Perspective View.
DIAMOND TRUCK FOR RUSSEL SNOW PLOW.
Journals and Arch Bars on Inside and Outside. Solid Wood Bolster with Flitch Plates.

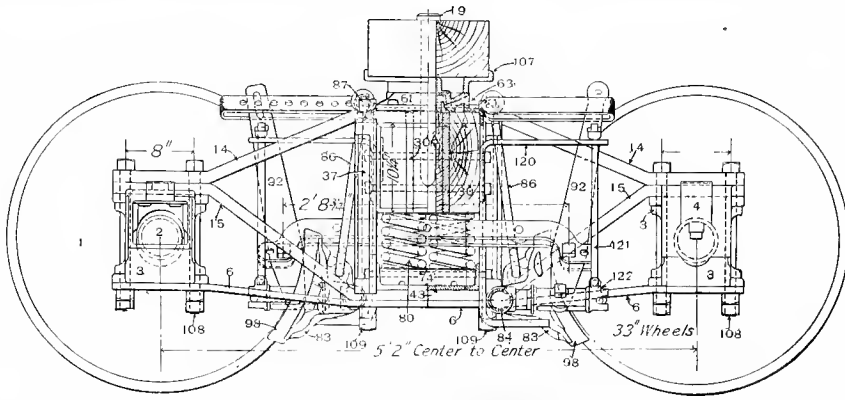

Fig. 4580 Sectional Side Elevation.

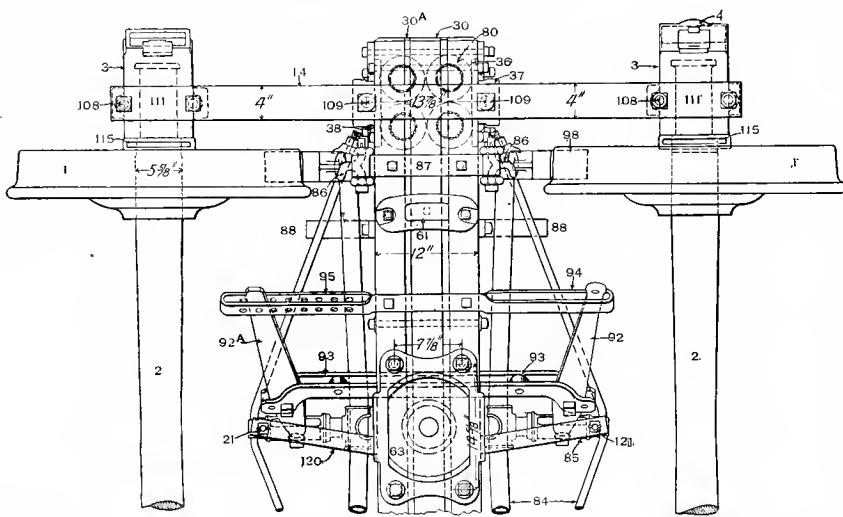

Fig. 4581. Part Plan.

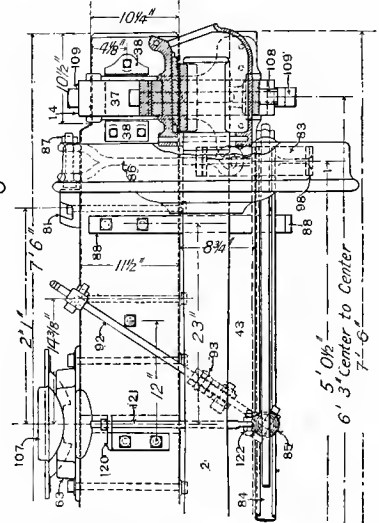
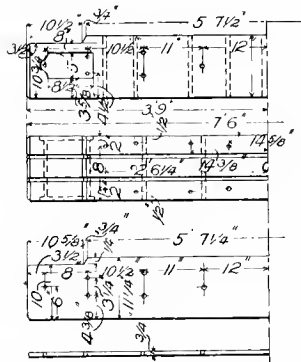
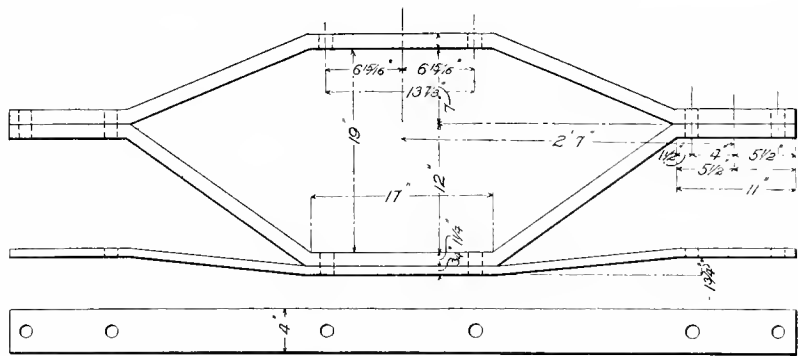

Fig. 4582. Part End Elevation.

RIGID DIAMOND FREIGHT-CAR TRUCK. NEW YORK, LAKE ERIE & WESTERN RAILROAD.



Figs. 4583-4586.
Half Elevations and Half Plans.
TRUCK-BOLSTER AND TRUCK-BOLSTER
FLITCH-PLATES.



Figs. 4587-4590.
UPPER AND LOWER ARCH-BARS AND TIE-BAR.

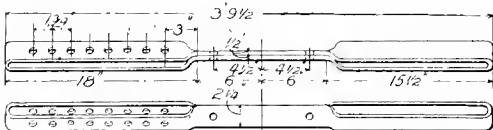

Figs. 4591-4592. BRAKE-LEVER STOP AND GUIDE.

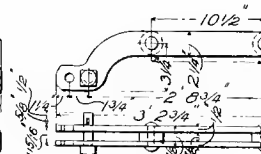

Figs. 4593-4594.
BRAKE-LEVER STRUT.

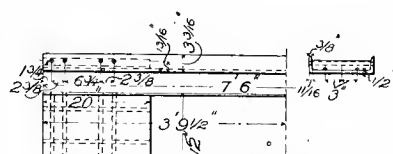

Figs. 4595-4597. SPRING-PLANK.
(Steel channel with wood filler.)

WROUGHT IRON AND STEEL DETAILS OF RIGID DIAMOND FREIGHT-CAR TRUCK. NEW YORK, LAKE ERIE & WESTERN RAILROAD.

Figs. 4593-4599. LIVE BRAKE LEVER.

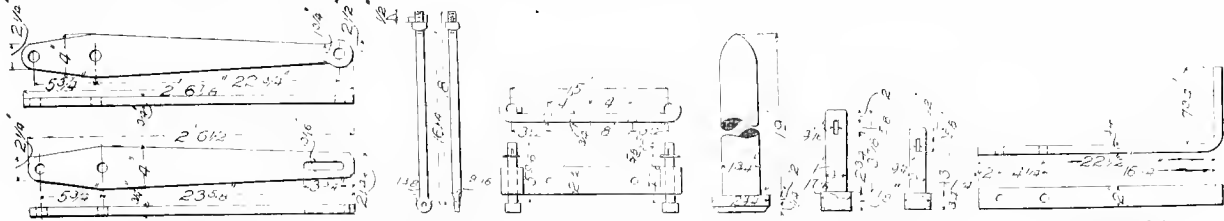

Figs. 4600-4601. DEAD BRAKE LEVER.

Figs. 4602-4603. BRAKE-BEAM ADJUSTING HANGER.

Figs. 4604-4605. BRAKE-HANGER CARRIER.

Fig. 4606. KING-BOLT.

Figs. 4607-4608. BRAKE-LEVER BOLTS.

Figs. 4609-4610. BRAKE-BEAM SAFETY-GUARD.

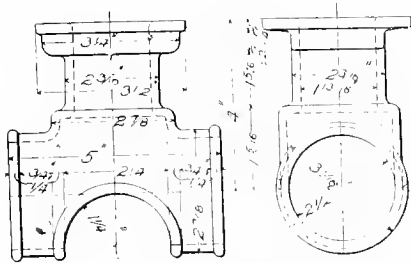

Figs. 4611-4612.

SLEEVE FOR UNIVERSAL BRAKE-BEAM STRUT.

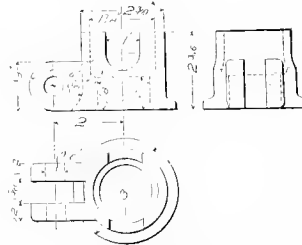

Figs. 4613-4615.

FULCRUM TRUSS-ROD END.

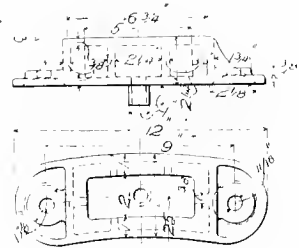

Figs. 4616-4617.

TRUCK SIDE-BEARING.

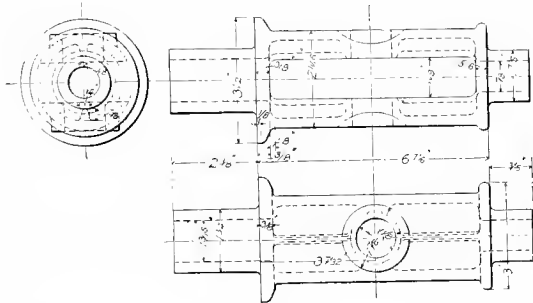

Figs. 4618-a-b.

CENTER-PIECE OF UNIVERSAL BRAKE-BEAM STRUT.
Brake-lever may be adjusted to any angle.

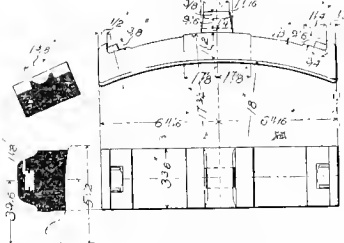

Figs. 4619-4622. BRAKE-SHOE.

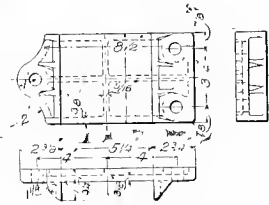

Figs. 4623-4625. BOLSTER GUIDE-CASTING.

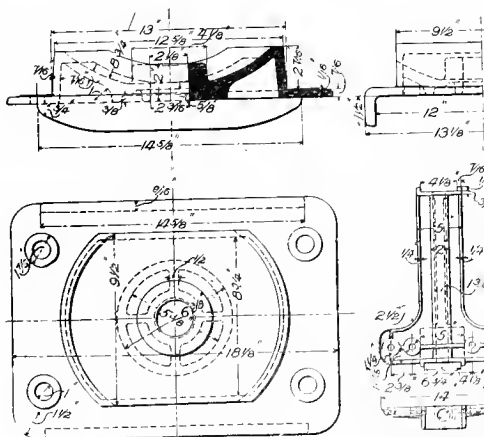

Figs. 4626-4628.

TRUCK CENTER-PLATE.

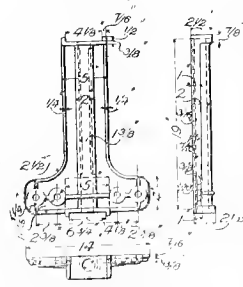

Figs. 4629-4631.

BOLSTER GUIDE-BARS OF TRUCK-COLUMNS.

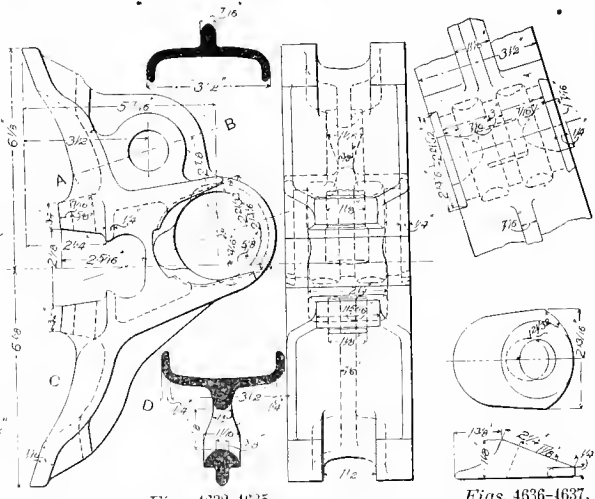

Figs. 4632-4635.

CHRISTIE BRAKE-HEAD FOR UNIVERSAL BRAKE-BEAM.

Figs. 4636-4637. BRAKE-BEAM TRUSS-ROD WASHER.

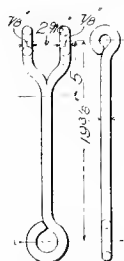

Figs. 4638-4639.

(331) BRAKE-HANGER.

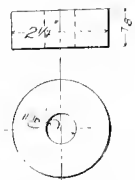

Figs. 4640-4641. CAST-WASHER.

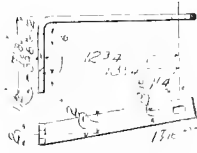

Figs. 4642-4643.

BRAKE-BEAM ADJUSTING HANGER CARRIER.

Details not given above are Master Car Builders' Standard, which are shown hereinafter. They include Journal Box, Journal-box Lid, Wedge, Brass, and 33-in. Chilled Wheels.

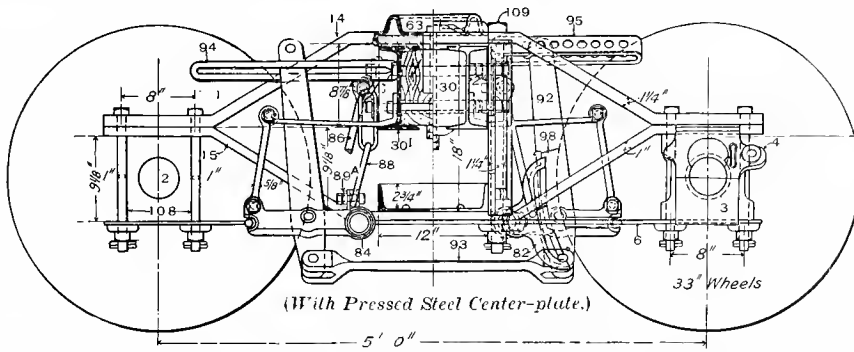

Fig. 4644. Half Longitudinal Section and Half Side Elevation.

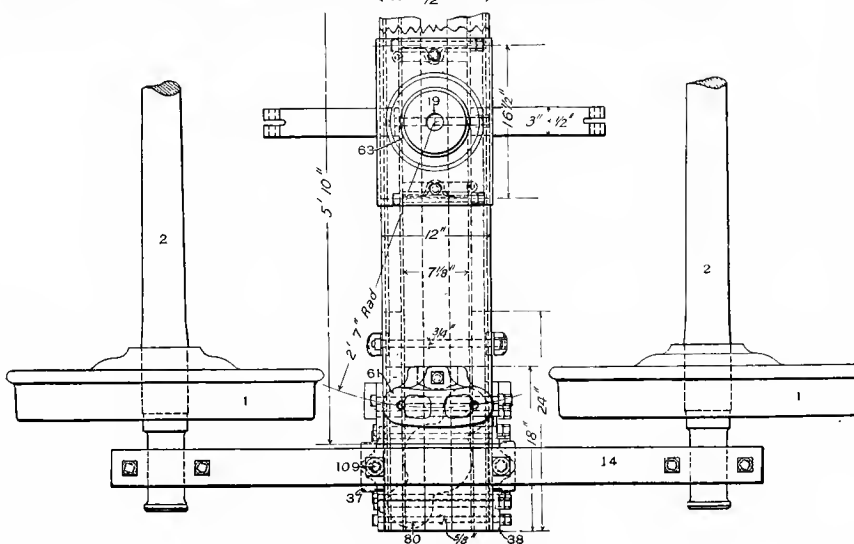

Fig. 4645. Part Plan.

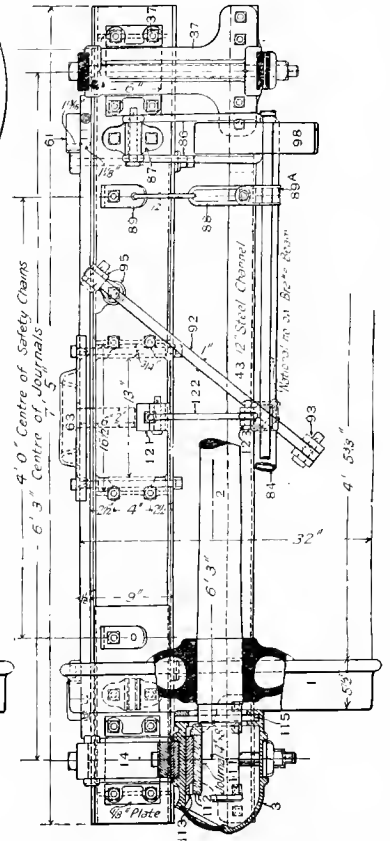

Fig. 4646. Half Cross Section and Half End Elevation.

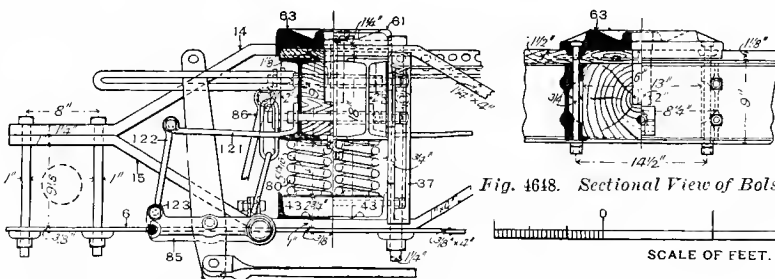

Fig. 4647. Half Longitudinal Section and Part Side Elevation. (With Malleable Iron Center-plate.)

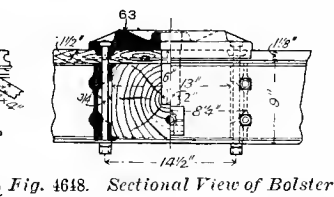
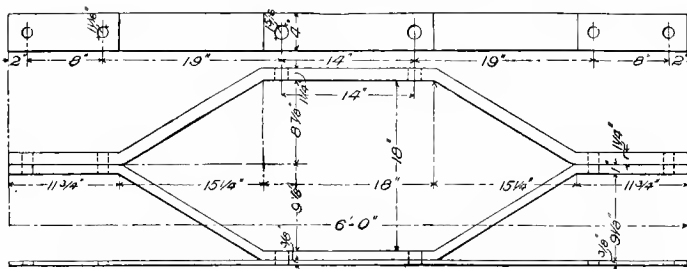

Fig. 4648. Sectional View of Bolster.

SCALE OF FEET.



Figs. 4619-4652. Upper and Lower Arch-bars and Tie-bar (2 of each).

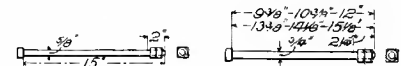

Fig. 4653. Transom Bolt (8).

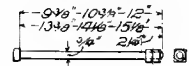
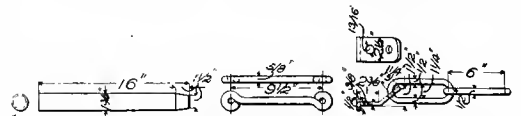
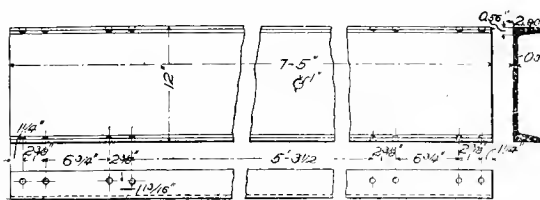

Fig. 4654. Bolts. (1, 2, 2, 2, 4 and 12 of each respectively.)



Figs. 4655-56. Center Pin (1). Figs. 4657-58. Brake-beam Adjusting-hanger (2). Figs. 4659-60. Brake-beam Safety-chain (4).



Figs. 4661-4663. Spring-plank Channel iron (1).

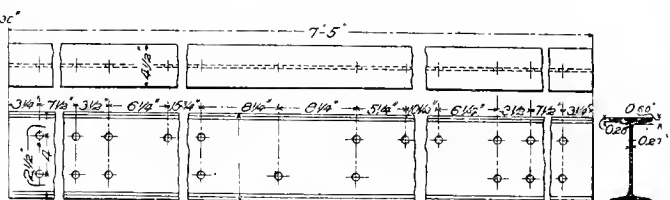

Figs. 4664-4666. Bolster I-Beam, Steel (2).

RIGID DIAMOND FREIGHT-CAR TRUCK. NORFOLK & WESTERN RAILROAD.
Truck-bolster is a Composite Girder Built of I-beams and Wood Filling-pieces.

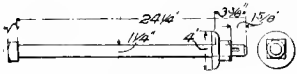

Fig. 4667. COLUMN-BOLT (4).

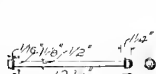

Fig. 4668. BOLSTER-PLANK BOLT (2).

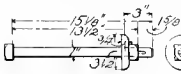

Fig. 4669. JOURNAL-BOX BOLT (8).

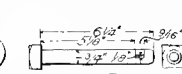

Fig. 4670. BRAKE-HANGER PIN (1).

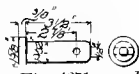
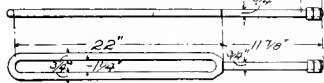

Fig. 4671. INTERMEDIATE BRAKE-PIN (6).



Figs. 4672-73. INTERMEDIATE BRAKE-HANGER PINS (2 of each).



Figs. 4674-5. LIVE-LEVER GUIDE (1).

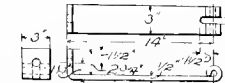

Figs. 4676-8. BRAKE-BEAM ADJUSTING-HANGER CARRIER (2).

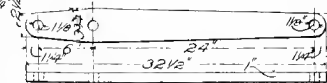

Figs. 4679-80. DEAD BRAKE-LEVER (1).

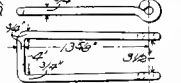

Figs. 4681-2. BRAKE-HANGER (4).

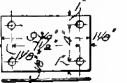

Figs. 4683-4. CHAFING-PLATE (4).

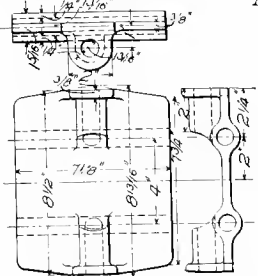

Figs. 4685-7. Intermediate (2).

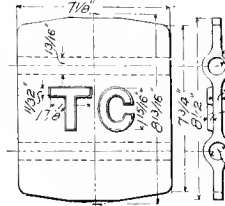

Figs. 4688-9. End (2)

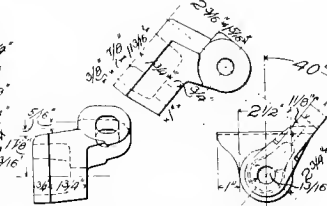

Figs. 4690-2. BRACKET FOR DEAD-LEVER GUIDE (1).

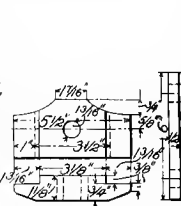

Figs. 4693-4. WASHER (2)

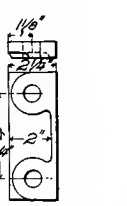

Figs. 4695-7. BOLSTER GUIDE-BLOCK (8).

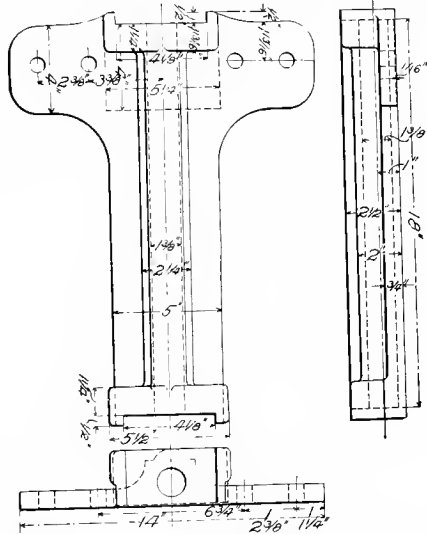

Figs. 4698-1700. BOLSTER GUIDE-BAR OR COLUMN.

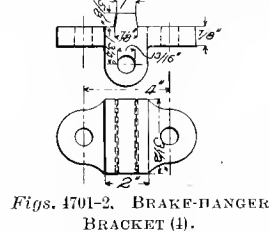

Figs. 4701-2. BRAKE-HANGER BRACKET (4).

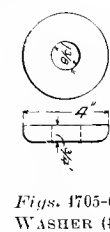

Figs. 4705-6. WASHER (4).

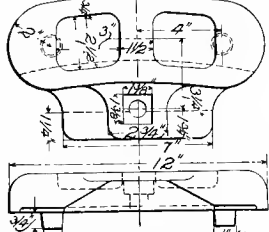

Figs. 4703-1. SIDE-BEARING (2).

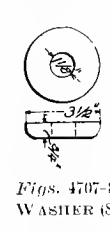

Figs. 4707-8. WASHER (8).

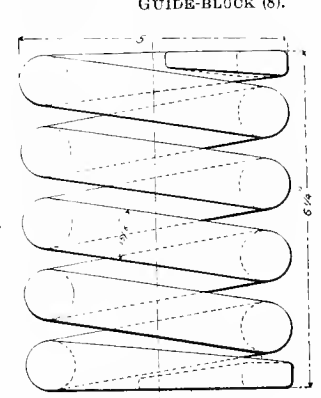
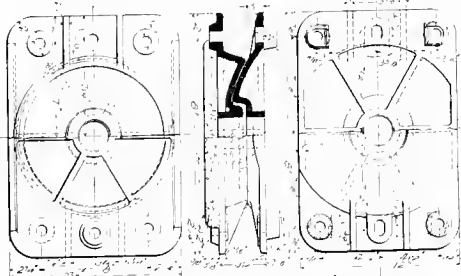
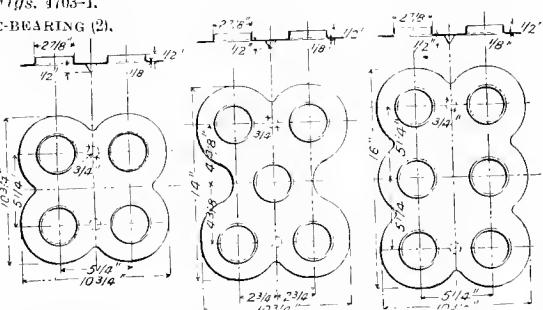

Fig. 4700. TRUCK BOLSTER SPRING. Standard Coil.



Figs. 4716-1720. MALLEABLE-IRON CENTER-PLATES.



Figs. 4710-4715. STEEL OR MALLEABLE-IRON SPRING-SEATS AND CAPS. For Cars of 40,000, 50,000 and 60,000 lbs. capacity respectively.



Figs. 4721-6. MALLEABLE-IRON BRAKE-STRUT.

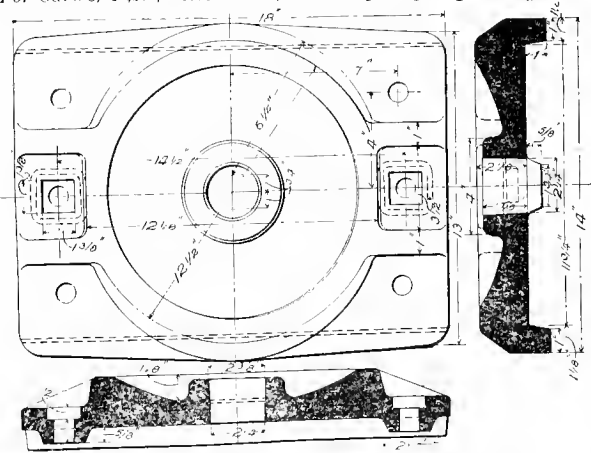

Figs. 4721-23. CAST-IRON TRUCK CENTER-PLATE.



Figs. 4727-8. DEAD-LEVER GUIDE AND STOP.

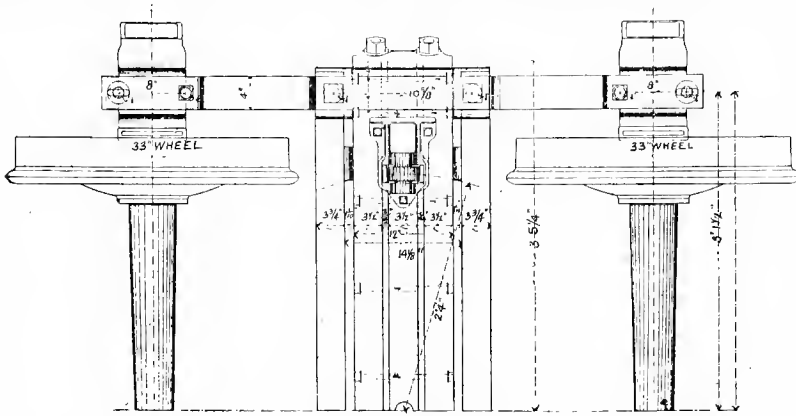

Fig. 4747. Half Plan.

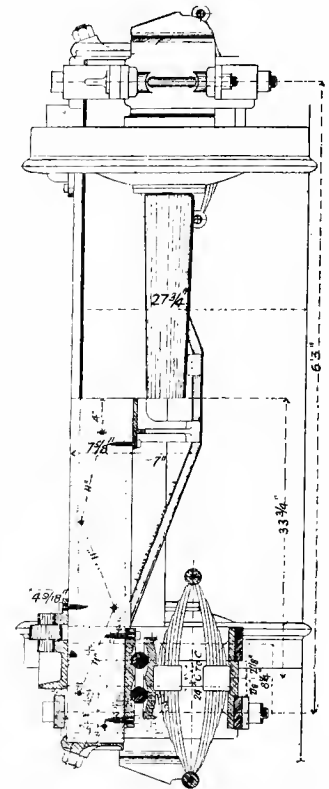

Fig. 4749. Half Cross Section and Half End Elevation.

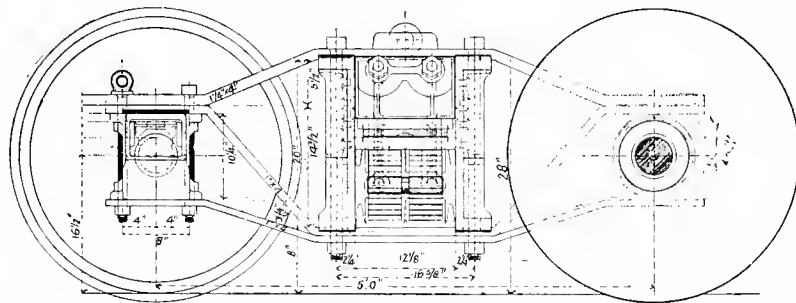

Fig. 4748. Sectional Side Elevation.

DREXEL ROLLER SIDE-BEARING TRUCK (BARBER PATENT). NORTHERN PACIFIC RAILROAD.

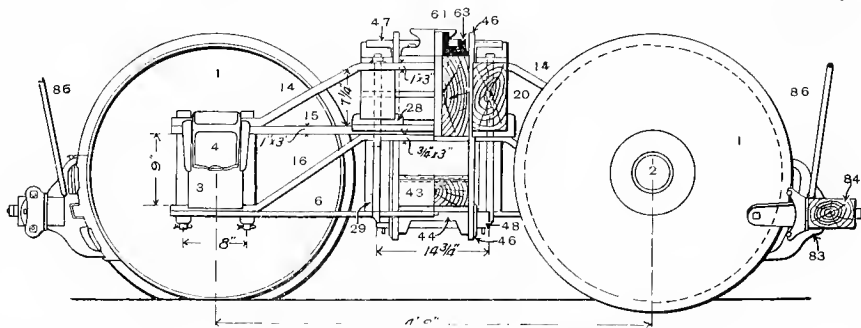

Fig. 4750. Half Side Elevation and Half Longitudinal Section.

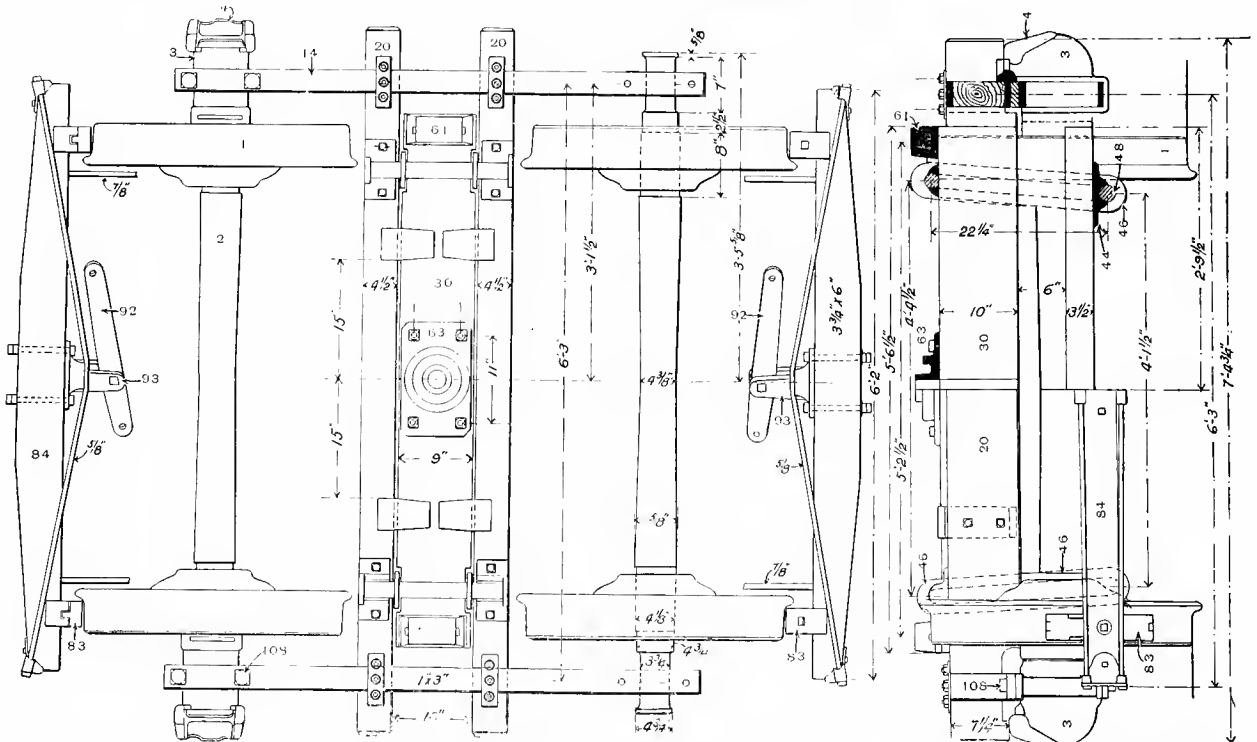

Fig. 4751. Plan.

SWING-MOTION CAROUSE-CAR TRUCK. WARASH RAILWAY.

Fig. 4752. Half End Elevation and Half Cross Section. (336)

Numbers refer to Names of Parts on Following Page.

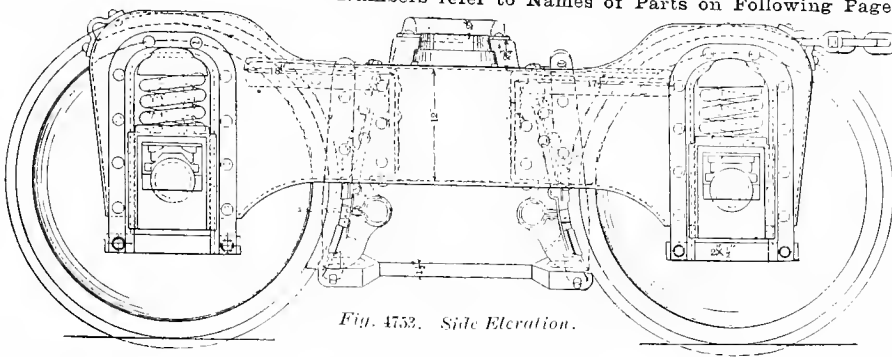

Fig. 4753. Side Elevation.

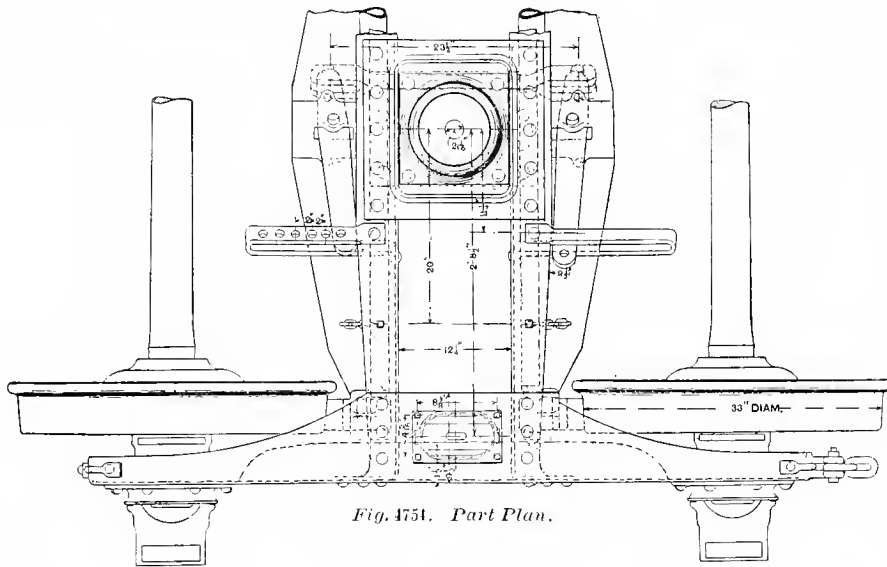

Fig. 4754. Part Plan.

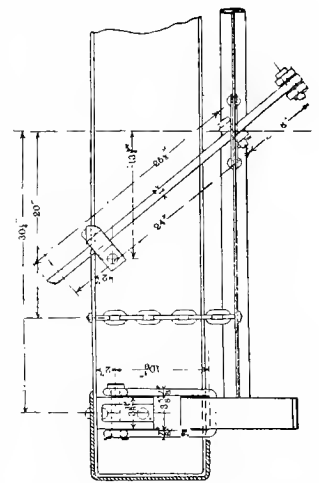

Fig. 4755. Part Sectional End Elevation.

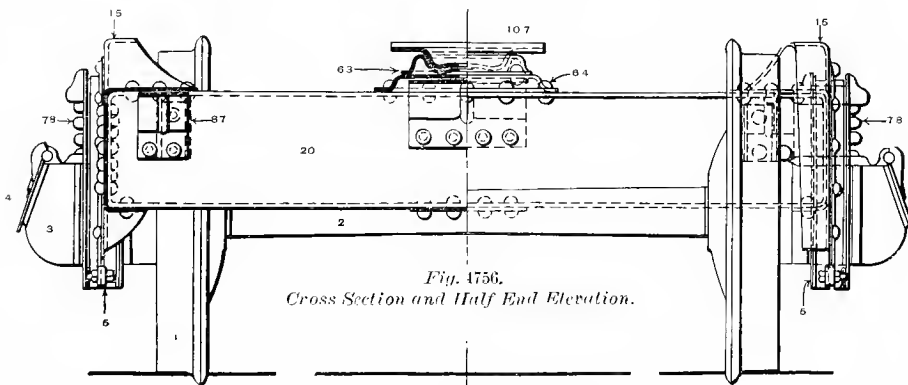

Fig. 4756. Cross Section and Half End Elevation.

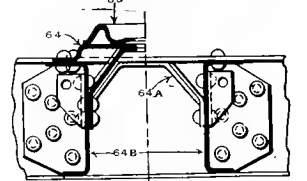
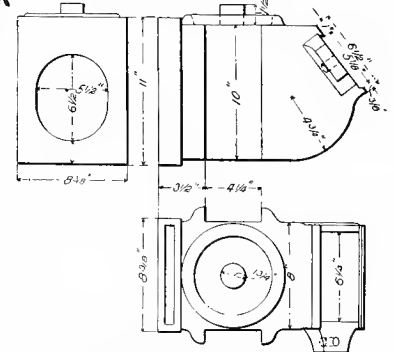
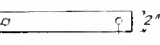

Fig. 4757. Longitudinal Section through Center Plate.



Figs. 4758-4760. Journal-box 4, DETAILS OF FOX STEEL TRUCK.



Figs. 4761-4762. Tie-pieces (1).

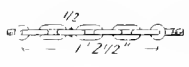
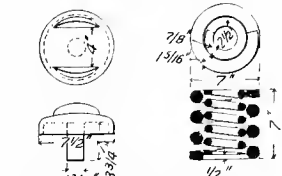
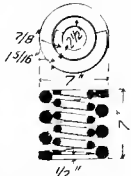

Fig. 4763. Safety Chains for Brake-beams (1).



Figs. 4764-4765. Spring-caps (4).



Figs. 4766-4767. Journal-box Spring (8).

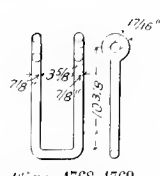

Figs. 4768-4769. Brake-beam Hangers (1).

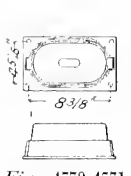

Figs. 4770-4771. King Side-bearings (2).

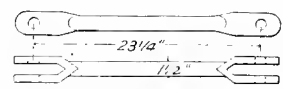

Figs. 4772-4773. Lever Connection (1).



Figs. 4774-4775. Safety-chain Loop.

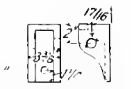

Figs. 4776-4777. Brake-beam Hanger Castings (4).

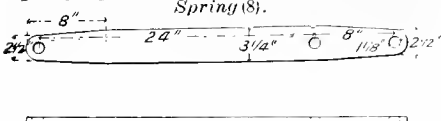

Figs. 4778-4779. Live Lever (1) and Dead Lever (1).

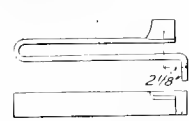

Figs. 4780-4781. Live-lever Guide (1).

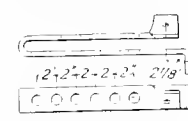

Figs. 4782-4783. Dead-lever Stop (1).

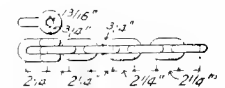

Figs. 4784-4785. Safety Chains and Hasps (4).

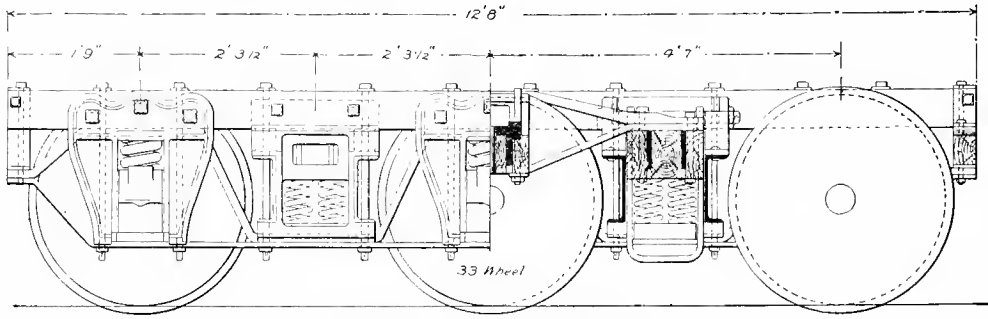

Fig. 4786. *Sectional Side Elevation.*

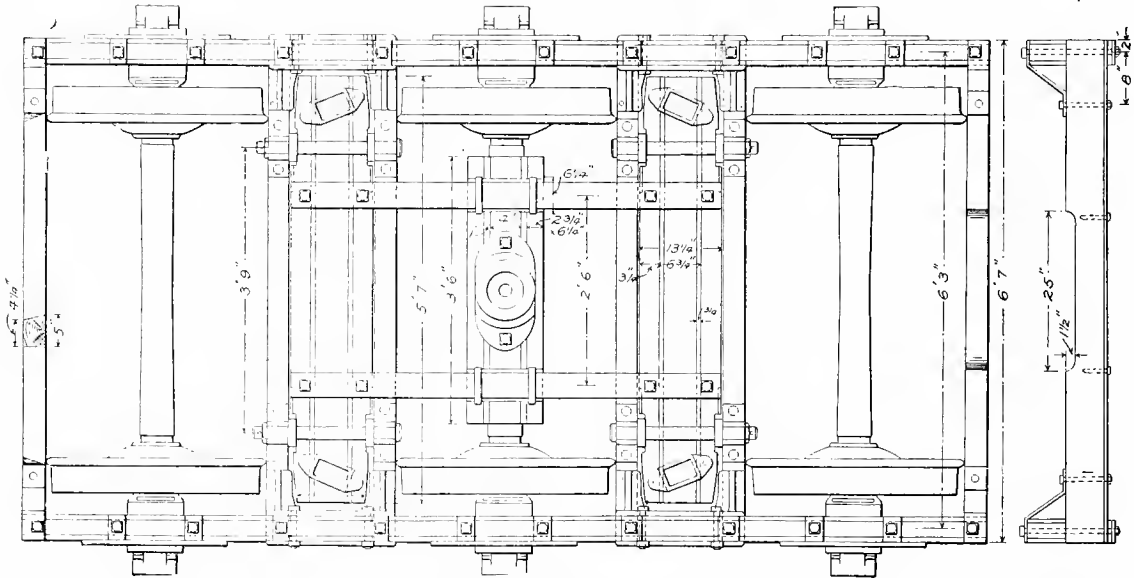

Fig. 4787. *Plan.*

Fig. 4788. *End-piece.*

SIX-WHEEL TRUCK FOR 50-TON FLAT-CAR. CHICAGO & NORTH WESTERN RAILWAY.
The car is shown in Figs. 290-293.

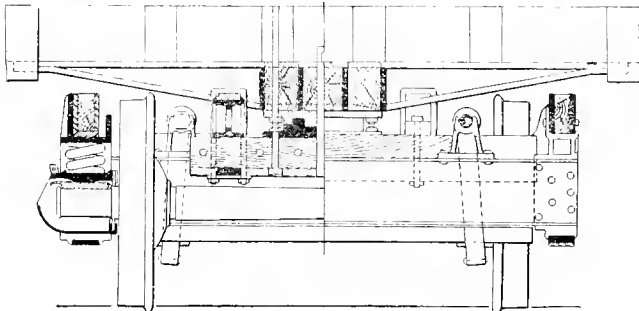
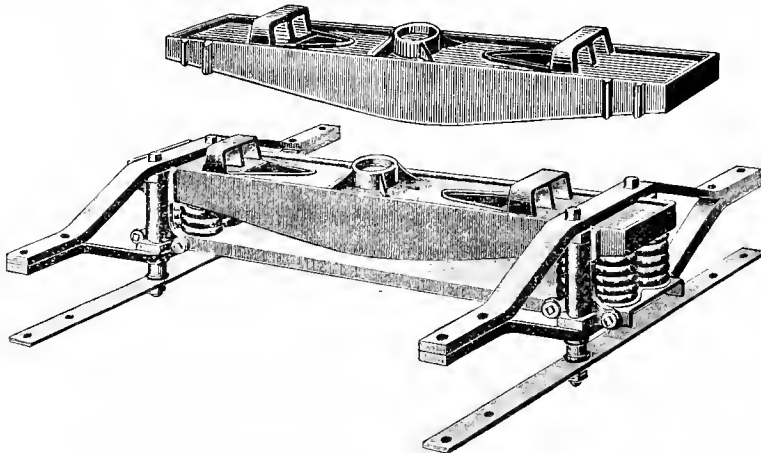

Fig. 4789. *Sectional End Elevation.*
TRUCK FOR 50-TON FLAT-CAR,

NAMES OF PARTS OF FOX TRUCK.

Figs. 4753-4757.

1. *Wheel.*
2. *Wheel-axle.*
3. *Journal-box.*
4. *Journal-box-lid.*
5. *Pedestal-brace.*
15. *Side-plate.*
20. *Transom.*
63. *Bottom Center-plate.*
64. *Base-plate.*
- 64a. *Side-bearing Strut.*
- 64b. *Transom (same as 20.)*
78. *Journal-spring.*
87. *Brake-hanger Bracket.*
107. *Body Center-plate.*



Figs. 4790-91. THE AMERICAN STEEL TRUCK-BOLSTER.
THE AMERICAN STEEL CASTING COMPANY.

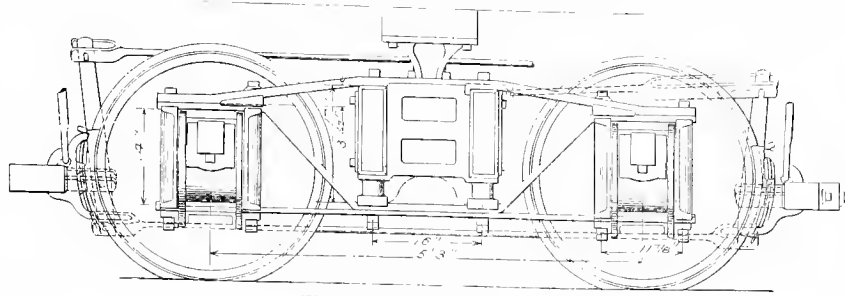
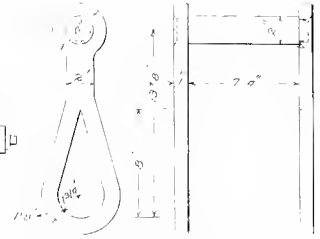

Fig. 4792. Side Elevation.



Figs. 4798-4799. JOURNAL-BOX SWING-LINK.

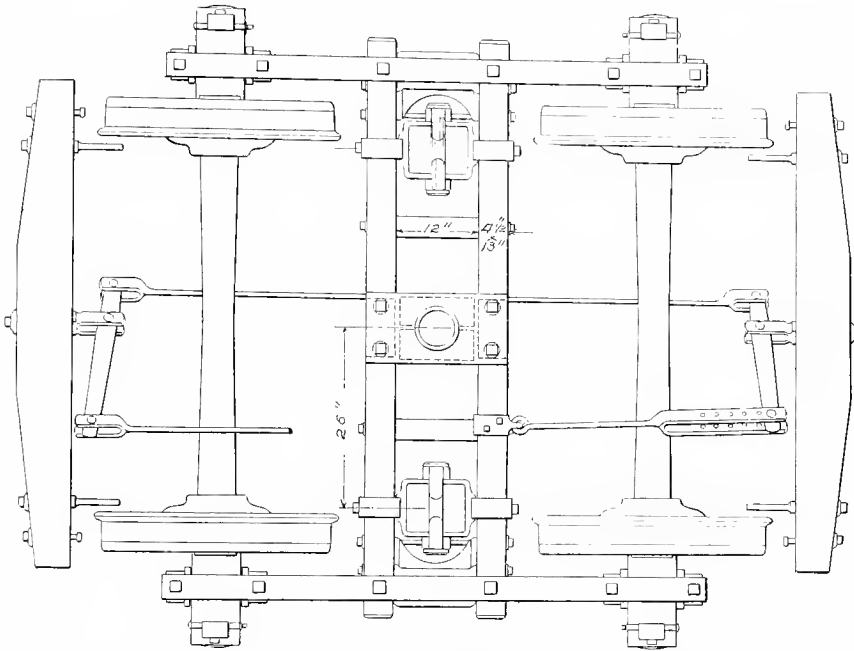

Fig. 4793. Plan of Truck.

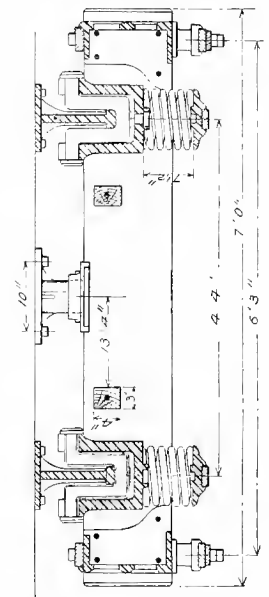

Fig. 4794. Cross Section.

THE CANDA FREIGHT-CAR TRUCK.

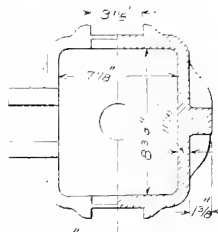
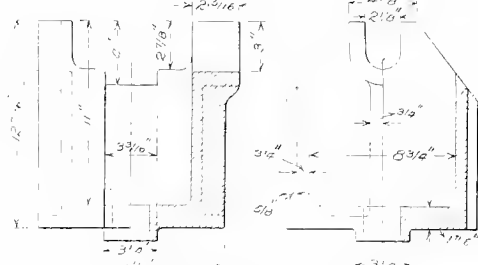
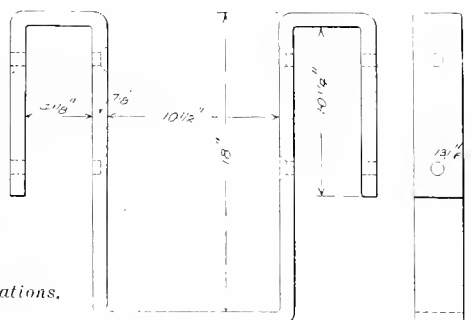

Fig. 4795. Plan of Body-bearing Casting.



Figs. 4796-4797. Sectional End and Side Elevations.

BODY-BEARING CASTING.



Figs. 4802-4803. SPRING-HANGER.

THE CANDA FREIGHT-CAR TRUCK AND DETAILS.

A special swing-motion truck, the frame of which is carried in stirrups bearing upon the journal-boxes, which leaves each pair of wheels free to move laterally.

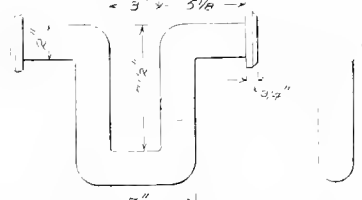

Figs. 4800-4801. SWING-LINK SIDE-BEARING.

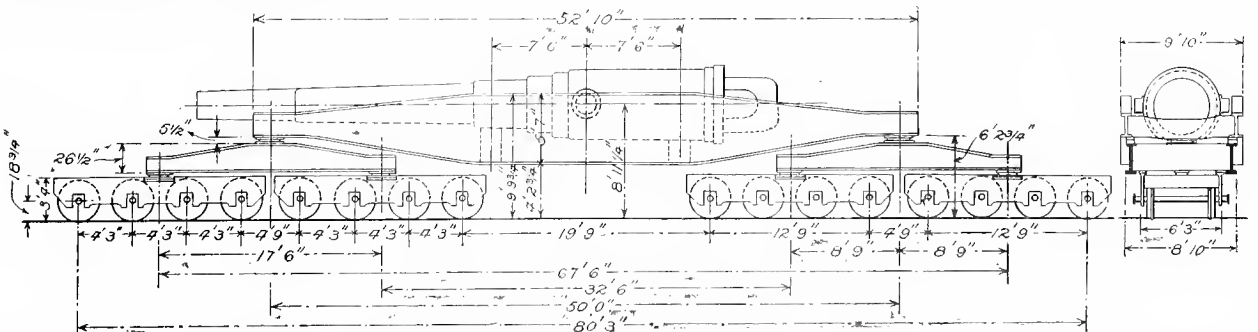

Figs. 4804-4805. SPECIAL TRUCK FOR CONVEYING LARGE GUNS. PENNSYLVANIA RAILROAD COMPANY.

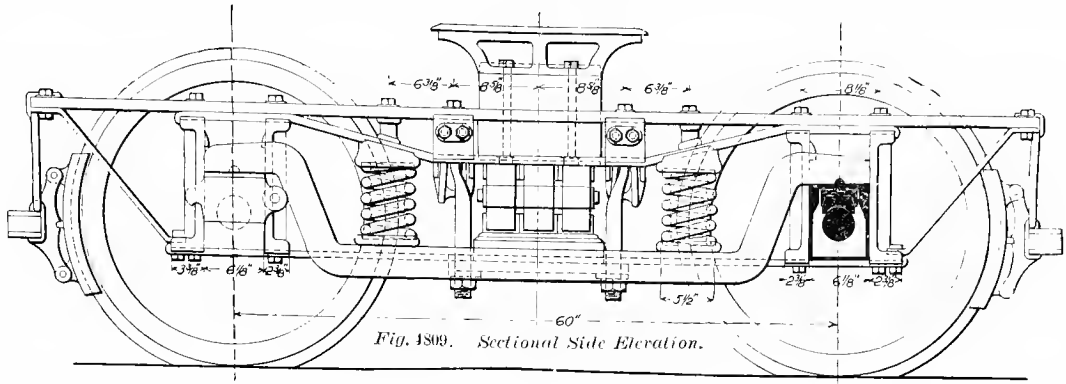

Fig. 4809. Sectional Side Elevation.

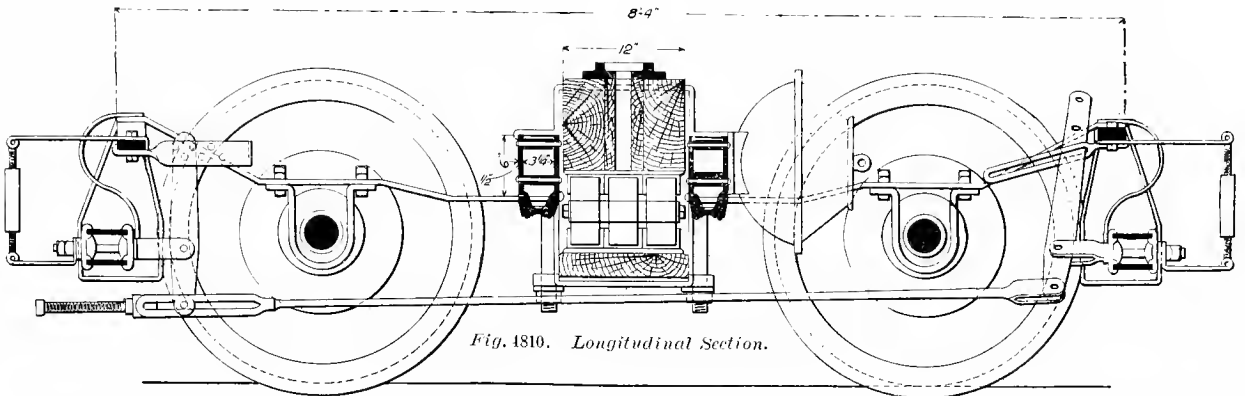

Fig. 4810. Longitudinal Section.

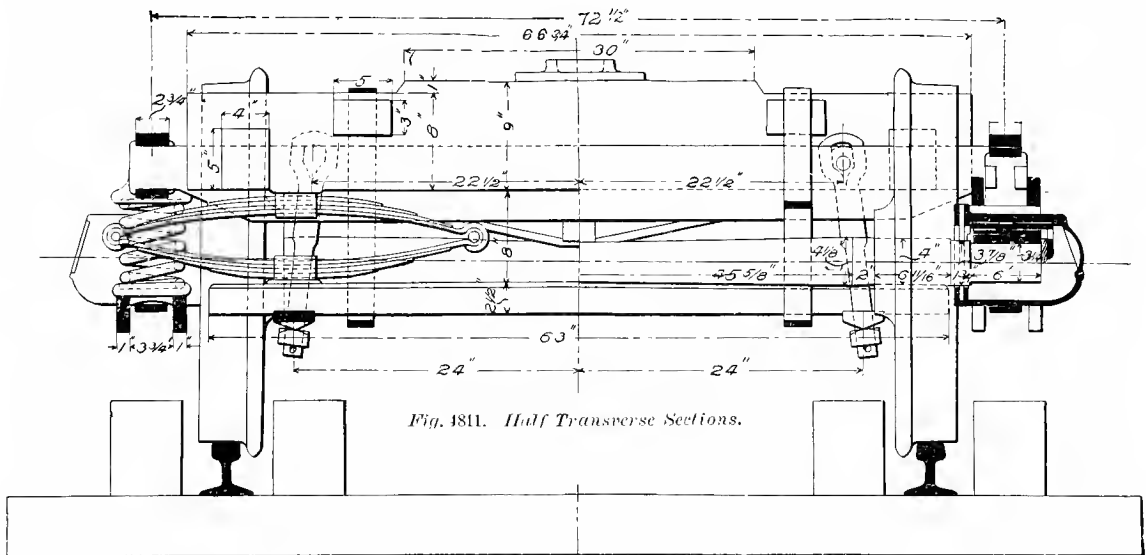

Fig. 4811. Half Transverse Sections.

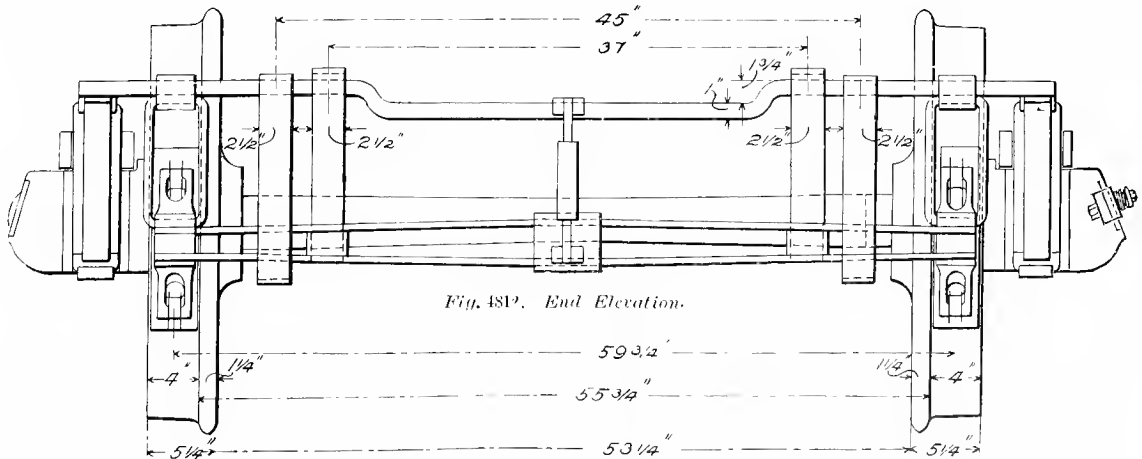

Fig. 4812. End Elevation.

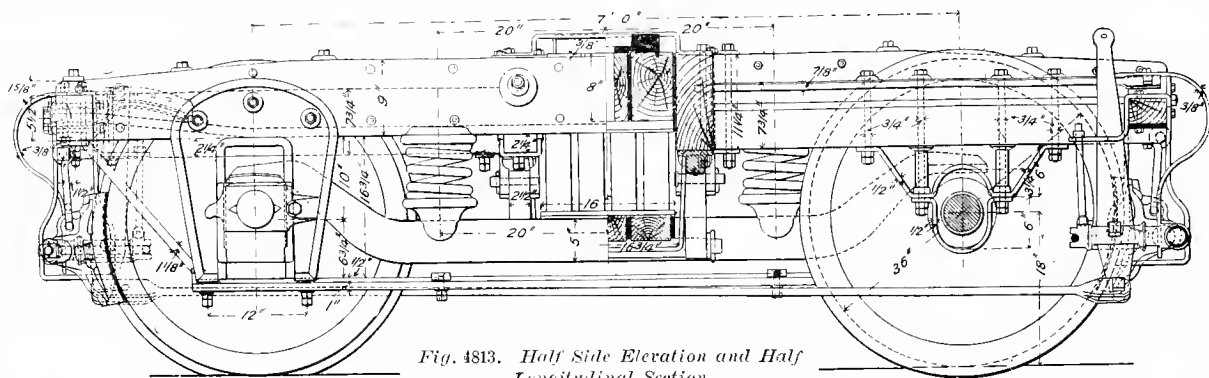

Fig. 4813. Half Side Elevation and Half Longitudinal Section.

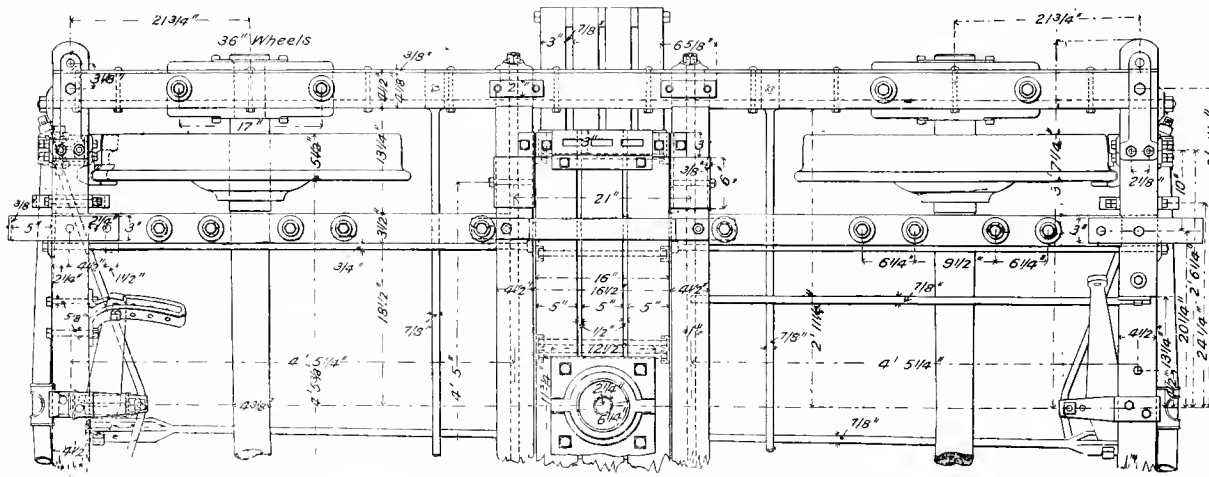

Fig. 4814. Half Plan.

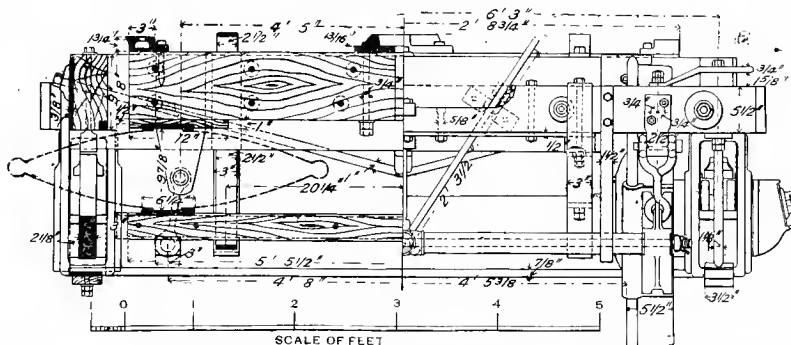
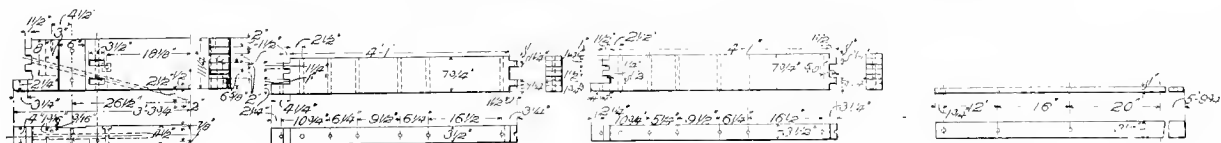

Fig. 4815. Half Cross Section and Half End Elevation.
PASSENGER-CAR TRUCK, FOUR-WHEELED. NEW YORK, LAKE ERIE & WESTERN RAILROAD.



Figs. 4816-4818. TRANSOM.

Figs. 4819-4821. AXLE-GUARD, BACK.

Figs. 4822-4824. AXLE-GUARD, FRONT.

Figs. 4825-4826. SPRING-PLANK FLITCH-PLATE.

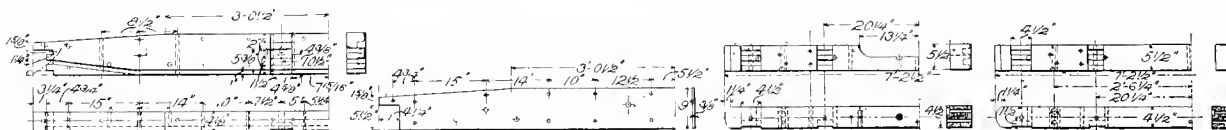

Figs. 4827-4829. WHEEL-PIECE.

Figs. 4830-4832. WHEEL-PIECE PLATE.

Figs. 4833-4835. FRONT END-PIECE.

Figs. 4836-4840. BACK END-PIECE.

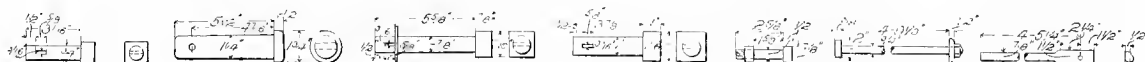

Figs. 4841-4842. BRAKE-LEVER BOLT.

Figs. 4843-4844. SWING-HANGER BOLT.

Figs. 4845-4846. PIN FOR BRAKE-HANGER.

Figs. 4847-4848. PIN FOR BRAKE-LEVER STOP.

Fig. 4849. BRAKE-BEAM ADJUSTING-ROD.

Fig. 4850. AXLE-GUARD PIN.

Fig. 4851. BRAKE-LEVER GUIDE.

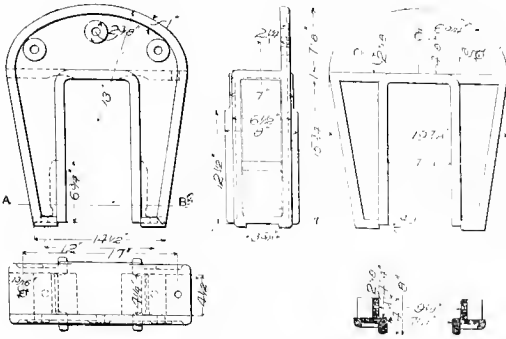

Figs. 4852-4856. PEDESTAL.

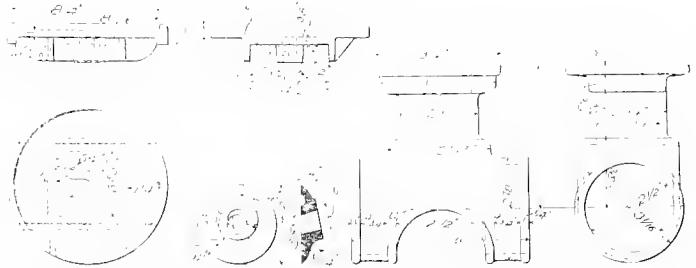

Figs. 4857-59. EQUALIZING-BAR SPRING CAP. Figs. 1860-61. TRANSOM TRUSS-ROD WASHER. Figs. 4862-63. BRAKE-BEAM SLEEVE, TO TAKE STRUT.

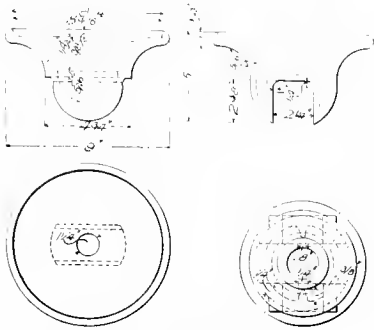

Figs. 4864-66. EQUALIZING-BAR SPRING-SEAT.

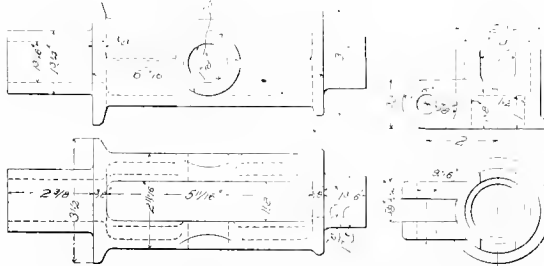

Figs. 4867-68. BRAKE-BEAM STRUT OR FULCRUM

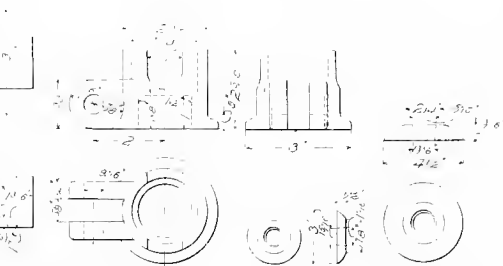

Figs. 4869-71. FULCRUM TRUSS-ROD END.

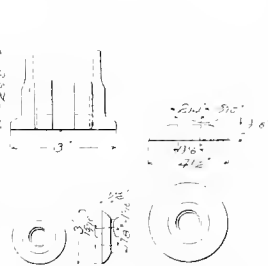

Figs. 4872-3. WASHER FOR WHEEL-TIMBER. 3/8-IN. BOLT. Figs. 4874-5. TRUSS-ROD WASHER.

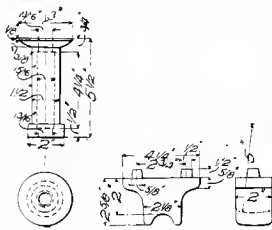

Figs. 4876-7. AXLE SAFETY-STRAP THIMBLE. Figs. 4878-9. TRANSOM TRUSS-ROD SEAT.

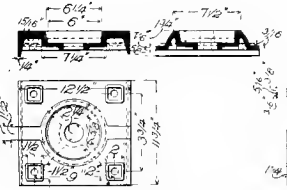

Figs. 4880-82. TRUCK CENTER-PLATE.

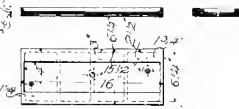

Figs. 4883-5. BOLSTER SPRING-SEAT.

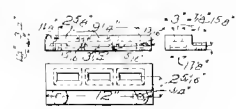

Figs. 4886-88. TRUCK SIDE-BEARING.

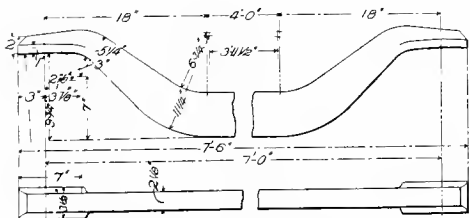

Figs. 4889-90. EQUALIZING-BAR.

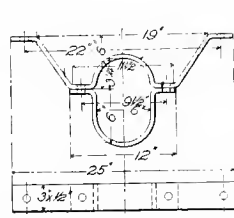

Figs. 4891-92. AXLE GUARD STRAP.

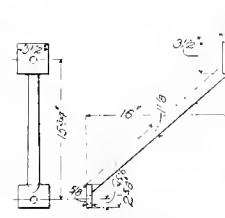

Figs. 4893-94. PEDESTAL-BRACE.

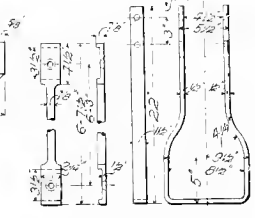

Figs. 4895-96. PEDESTAL BRAKE-BEAM TIE-BAR SAFETY-STAY-ROD. Figs. 4897-98. HANGER.

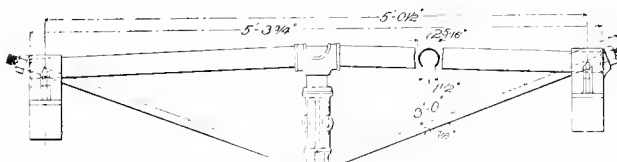

Figs. 4899. Plan. UNIVERSAL BRAKE-BEAM.

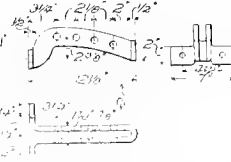

Figs. 4900-2. DEAD-LEVER STOP.

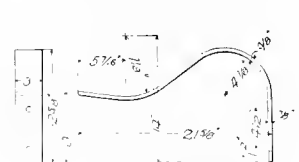

Figs. 4903-4. BRAKE-BEAM RELEASE-SPRING.

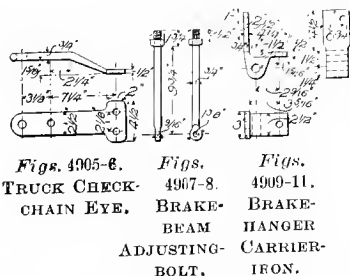

Figs. 4905-6. TRUCK CHECK-CHAIN EYE. Figs. 4907-8. BRAKE-BEAM ADJUSTING-BOLT.



Figs. 4909-11. BRAKE-BEAM HANGER. Figs. 4912-13. BOLSTER CHAFING-PLATE.

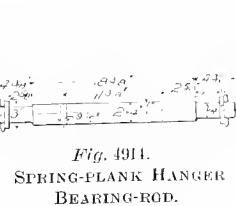
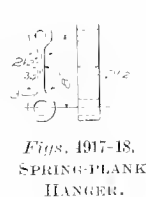

Fig. 4914. SPRING-PLANK HANGER BEARING-ROD.



Figs. 4915-16. TRANSOM TIE-BAR.



Figs. 4917-18. SPRING-PLANK HANGER.

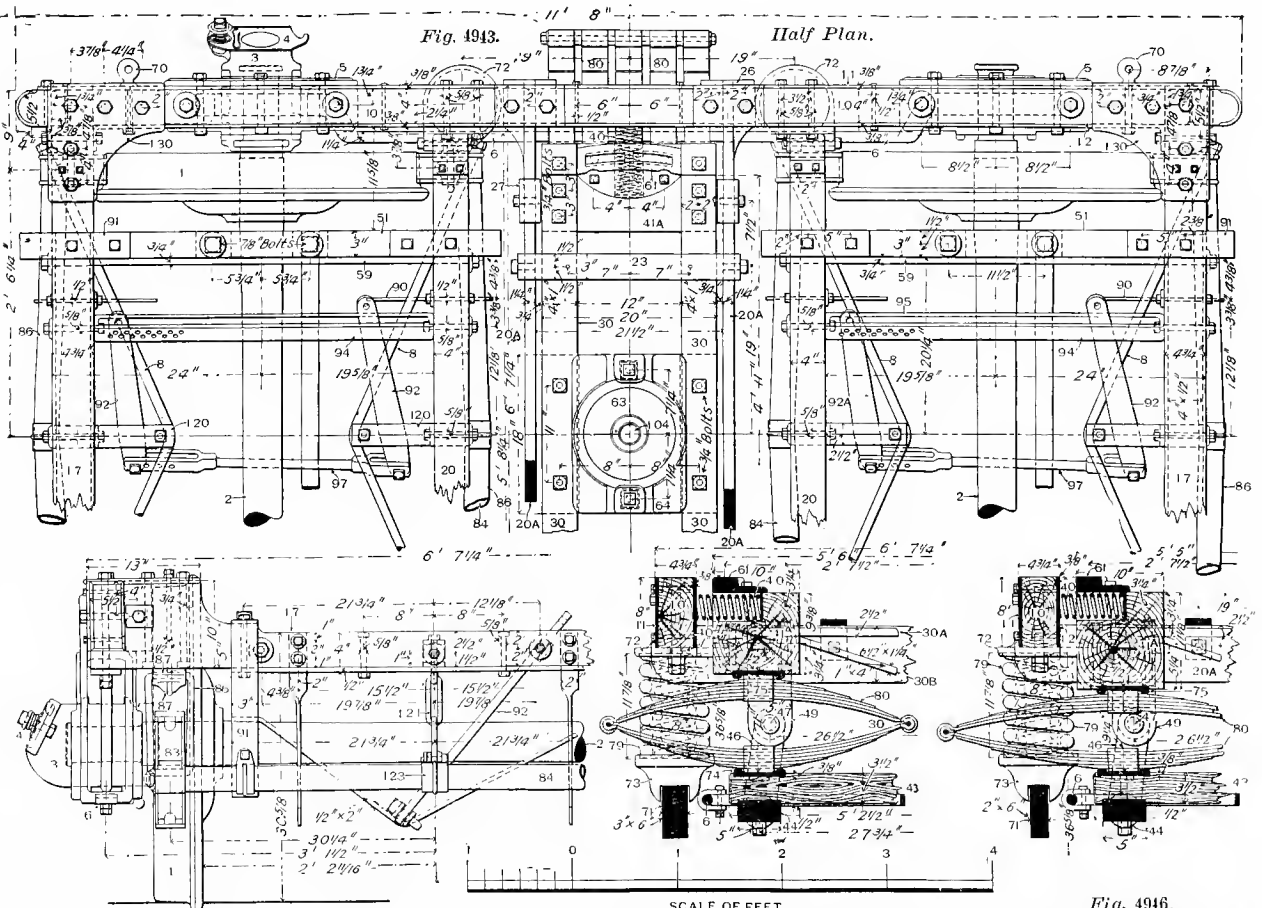
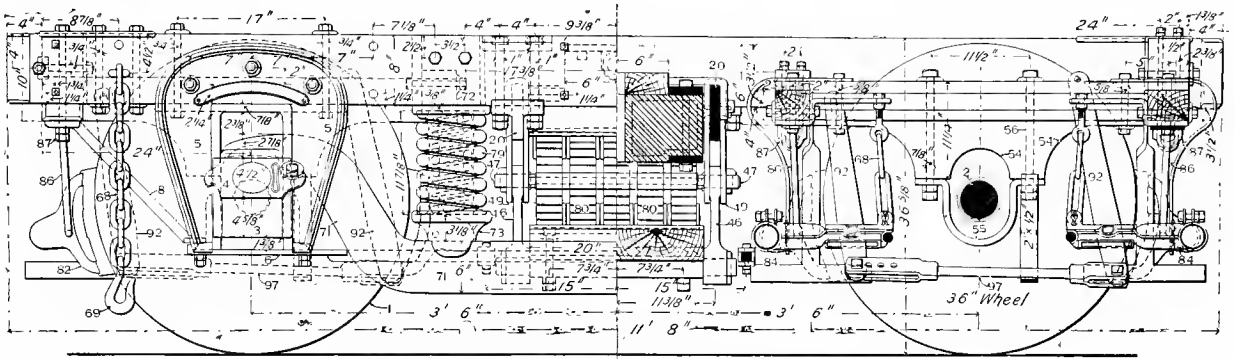
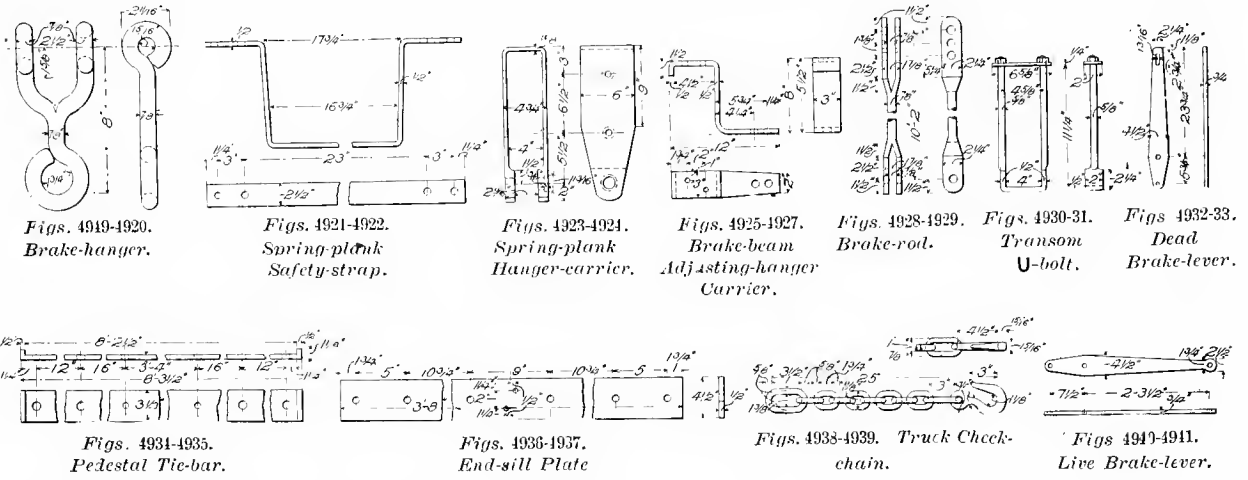

Fig. 4944. Part End Elevation.

Fig. 4945. Part Cross Section of a Baggage-car Truck.

Fig. 4946. Part Cross Section of a Passenger-car Truck.

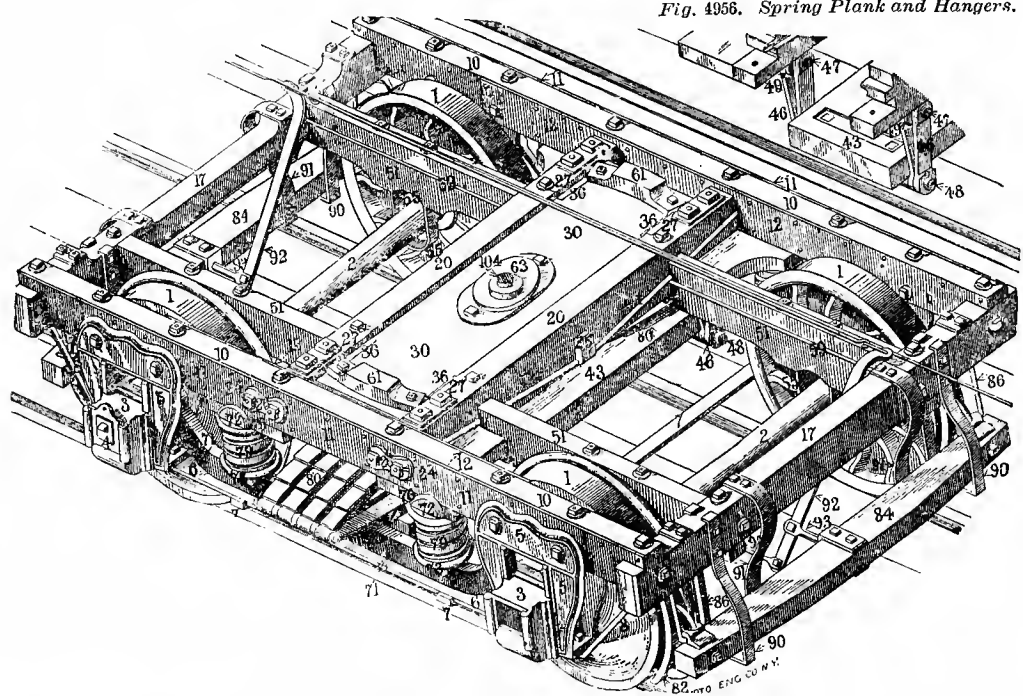

Fig. 4956. Spring Plank and Hangers.

Fig. 4955. A PERSPECTIVE VIEW OF A FOUR-WHEELED TRUCK.

An Old Pattern, Given for reference to Names of Parts, which are essentially the Same as in the More Modern Trucks.

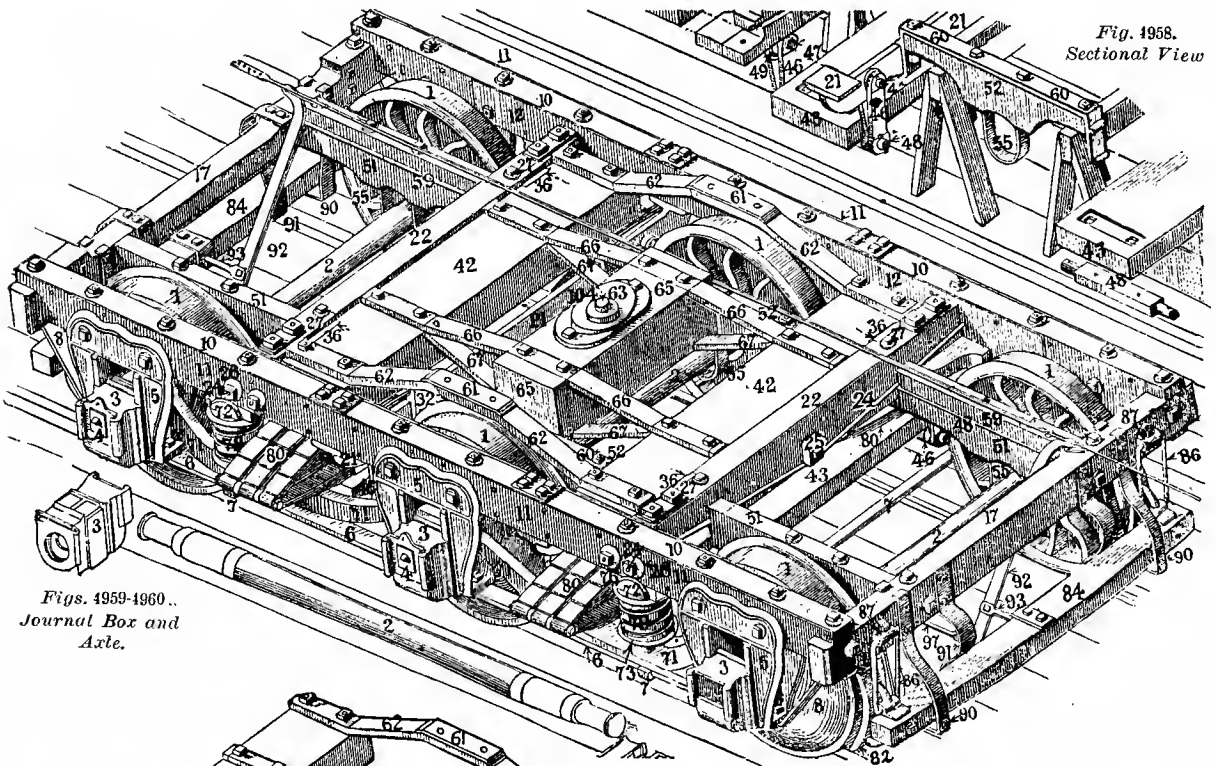

Fig. 4958. Sectional View

Figs. 4959-4960..
Journal Box and
Axle.

Fig. 4957.

A PERSPECTIVE VIEW OF A SIX-WHEELED TRUCK.
An Old Pattern, Given for reference to Names of Parts,
which are essentially the Same as in the
More Modern Truck, shown on
Opposite Page.

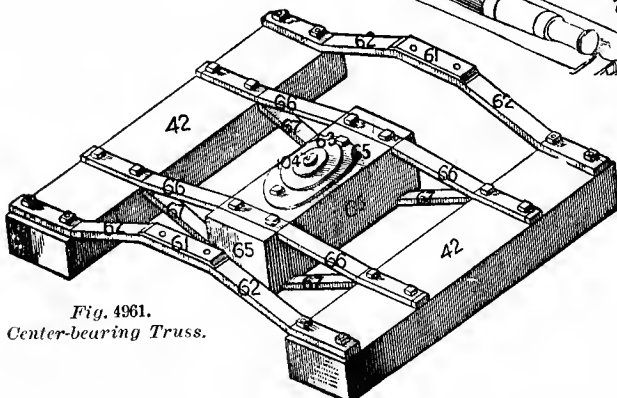
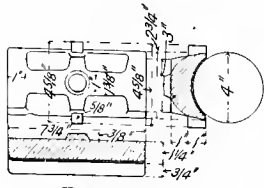
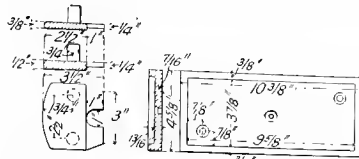

Fig. 4961.
Center-bearing Truss.



Figs. 5028-30. JOURNAL-BEARING OR BRASS.



Figs. 5031-32. STOP-PLATE.

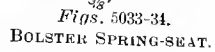

Figs. 5033-34. BOLSTER SPRING SEAT.

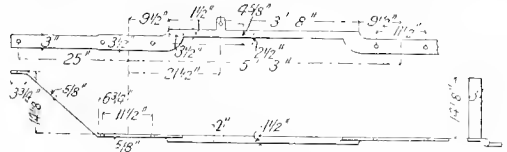

Figs. 5035-37. PEDESTAL TIE-BAR.

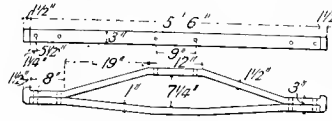

Figs. 5038-39. BODY CENTER-BEARING TRUSS.



Figs. 5040-41. TRUCK CENTER-BEARING TRUSS.

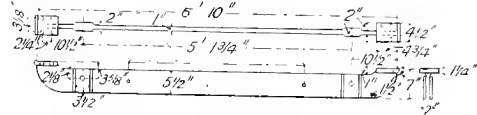

Figs. 5042-43. MIDDLE TRANSOM.

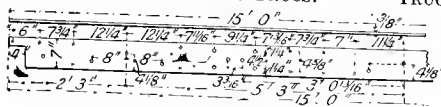

Figs. 5044-45. SWING-BEAM FLITCH PLATE. (Inside.)

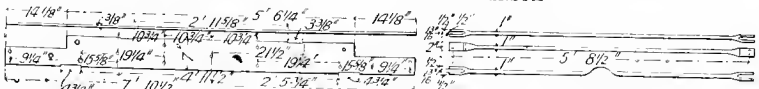

Figs. 5046-47. SWING-BEAM FLITCH-PLATE. (Outside.)

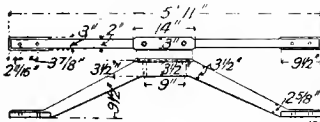

Figs. 5050-51. TRUCK SIDE-BEARING.

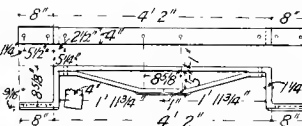

Figs. 5052-53. BODY SIDE-BEARING TRUSS.

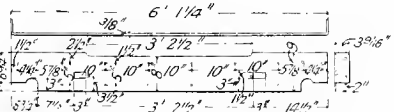

Figs. 5054-55. TRANSOM-PLATE.

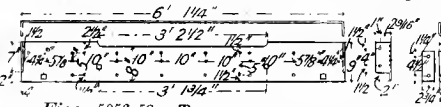

Figs. 5056-58. TRANSOM-PLATE.

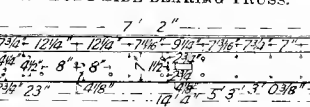

Figs. 5059-61. WHEEL-PIECE PLATE.

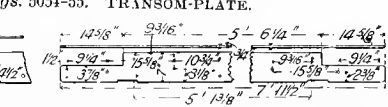

Figs. 5062-63. SWING-BEAM FLITCH-PLATE. (Inside.)

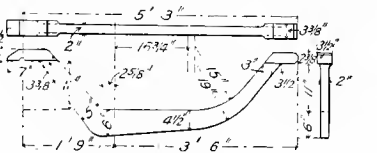

Figs. 5064-66. TRACK EQUALIZER.

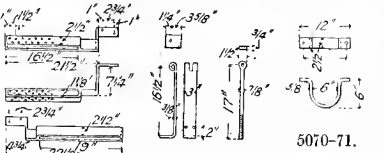

Figs. 5067-69. BRAKE-LEVER SPRING AND EYE-GUIDES.

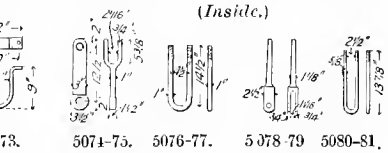

Figs. 5070-71. END AND CENTER AXLE-GUARDS.

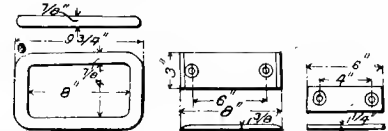

Figs. 5072-73. BOLSTER-HANGER AND U-BOLT.

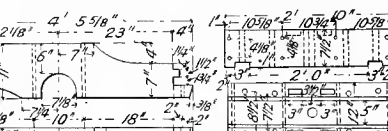

Figs. 5074-75. 5076-77. 5078-79 5080-81. BRAKE-HANGER AND U-BOLT.

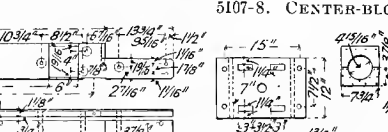

Figs. 5082-84-85. END AND CENTER ADJUSTING SPRING AND EYE-BOLT.



Figs. 5086-87. CENTER-BLOCK FLITCH-PLATE.

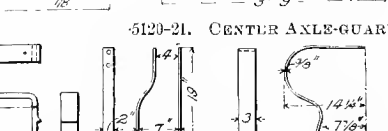
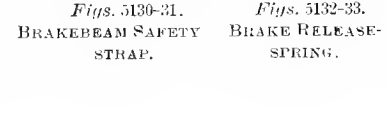

Fig. 5088. TRANSOM TIE-ROD.



Figs. 5089-92. CHAFING-PLATE AND EYE-BOLT. SAFETY-CHAINS.



Figs. 5095-96. BRAKE-HANGER.

Figs. 5097-98. 5099-5100. CHAFING-PLATES.

Figs. 5105-6. END AXLE-GUARD.

Fig. 5107-8. CENTER-BLOCK.

Figs. 5109-10. END-PIECE.

Figs. 5111-12. BOLSTER.

Figs. 5113-14. 5115 1 CENTER-PLATE DUST-BLOCK. GUARD.

Figs. 5118-19. WHEEL-PIECE.

Figs. 5122-23. BRAKE-LEVER.

Figs. 5124-25. BRAKE-LEVER.

Fig. 5126. BOLSTER-HANGER.

Figs. 5127-29. AXLE-GUARD TRUSS.

Figs. 5130-31. BRAKE-BEAM SAFETY STRAP.

Figs. 5132-33. BRAKE RELEASE-SPRING.

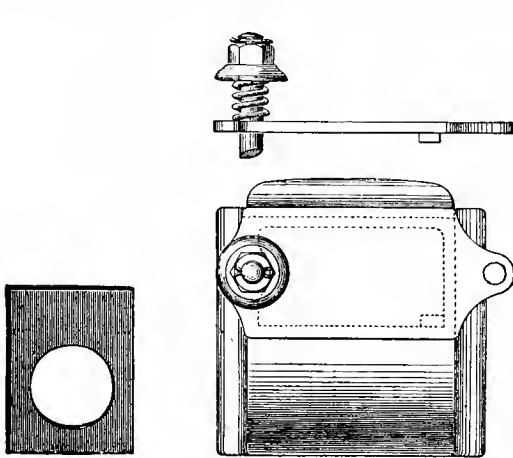

Fig 5154
DUST-GUARD.

Figs. 5152-5153.
FLETCHER JOURNAL-BOX LID.

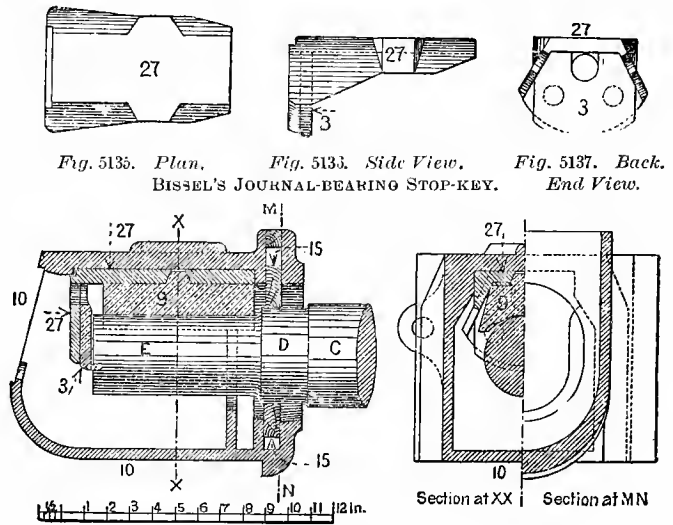

Fig. 5133. Plan, Fig. 5133. Side View, Fig. 5137. Back End View.
BISSEL'S JOURNAL-BEARING STOP-KEY.

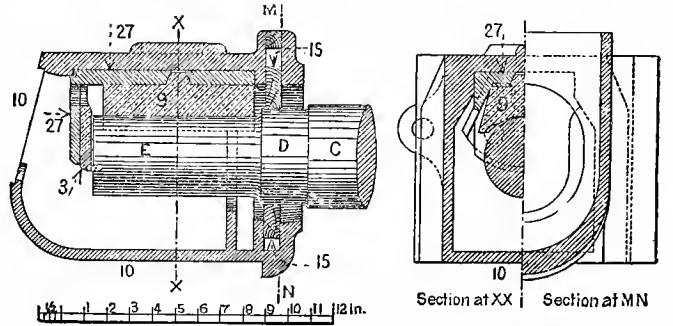
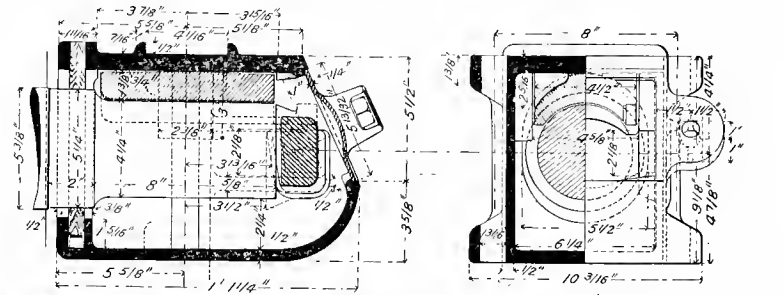

Fig. 5133. Section. Fig. 5134.
BISSEL'S STOP-KEY JOURNAL BEARINGS FOR COLLARLESS JOURNALS.

NAMES OF PARTS. Figs. 5146-5151.

1. Journal-box.
2. Journal.
3. Journal-bearing.
5. Stop-wedge.
6. Stop-wedge Axle-bearing.
7. Journal-box Lid.
8. Fiber-ring.
9. Collar Shrunk on Axle (malleable iron).
10. Dust-guard Felt.
11. Oil-retaining Lip.
12. Dust-guard Bearing.
13. Neck for Dust-collar.
14. Journal-box-cover Spring-cap.
15. Journal-box-cover Spring.
16. Journal-box-cover Bolt.



Figs. 5138-5139. Sections and End Elevation.

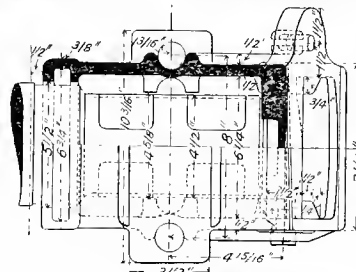
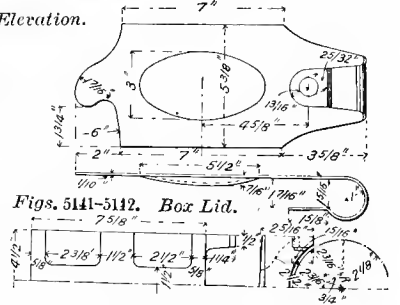

Fig. 5140. Sectional Plan.



Figs. 5141-5142. Box Lid.

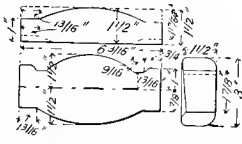

Fig. 5145. Stop-wedge.

JOURNAL-BOX AND CONTAINED PARTS FOR COLLARLESS JOURNALS. CHICAGO, BURLINGTON & QUINCY RAILROAD.

NAMES OF PARTS.

Figs. 5133-5137.

- C. Wheel-seat.
- D. Dust-guard Bearing.
- E. Journal.
3. Stop-plate.
9. Stop-key Journal-bearing.
10. Journal box.
15. Dust-guard.
27. Journal-bearing Stop-key.

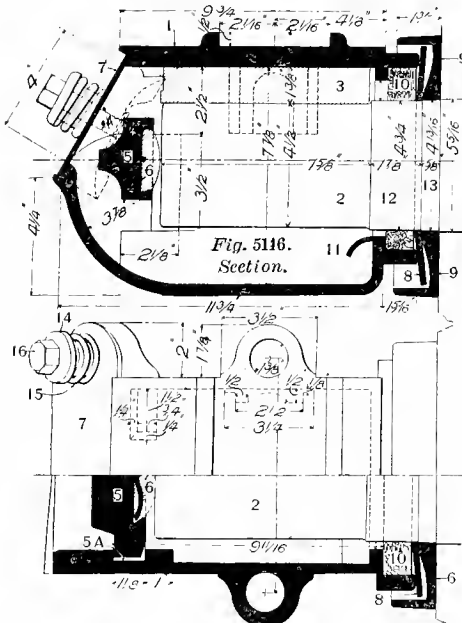

Fig. 5146.
Section.

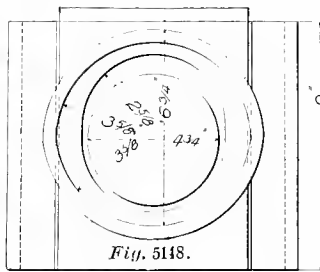
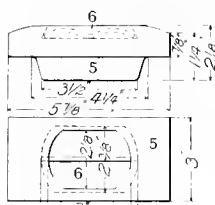

Fig. 5148.



Figs. 5150-5151.
Stop-wedge.

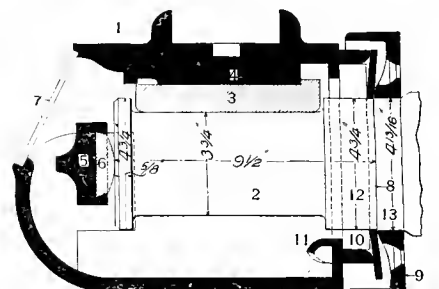
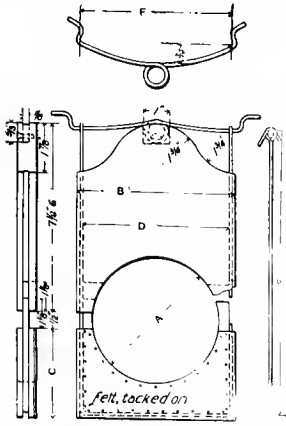
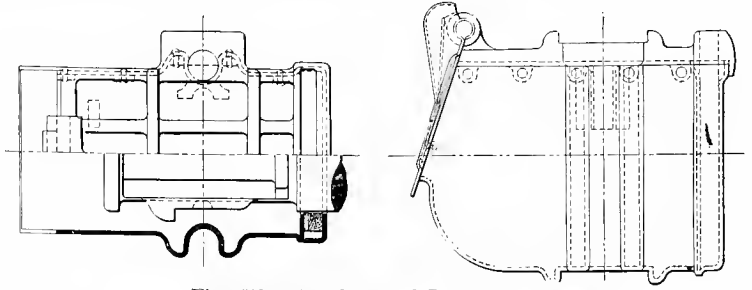

Fig. 5149. Applied to a Collared Journal.
BOSTON & ALBANY RAILROAD. (350)

THE ADAMS' JOURNAL-BOX AND CONTAINED PARTS FOR COLLARLESS JOURNALS.



Figs. 5155-5158.
THE STIER DUST-GUARD.



Figs. 5161-5162. Sectional Plan and Elevation.

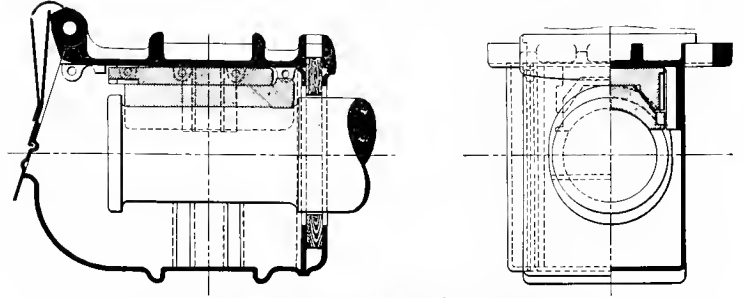

Figs. 5163-5164. Longitudinal and Cross Sections.
SCHOEN SOLID PRESSED-STEEL JOURNAL-BOX.

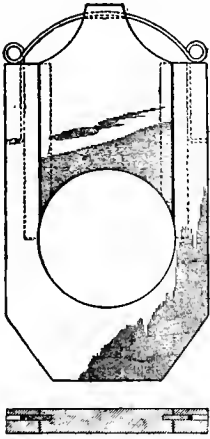

Figs. 5159 5160.
THE AMERICAN DUST-GUARD.

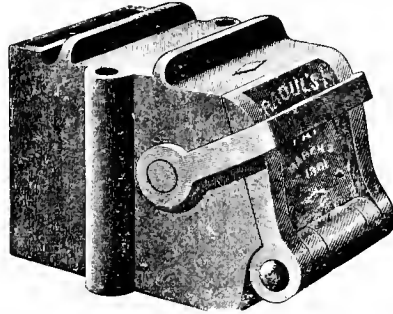

Fig. 5165.
THE RAUL JOURNAL-BOX.

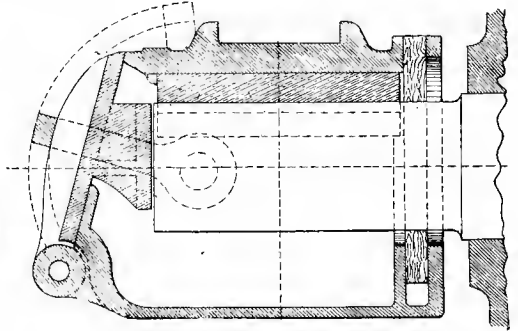

Fig. 5166. Section.
THE RAUL JOURNAL-BOX.

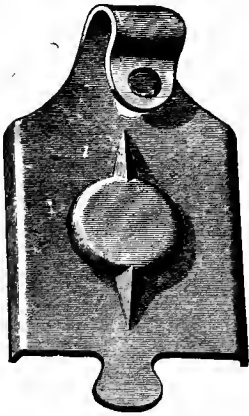

Fig. 5167.

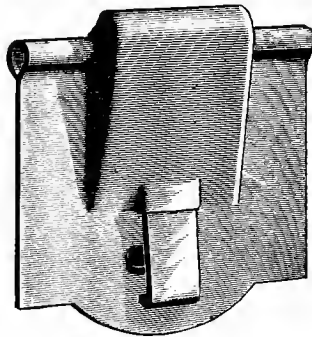

Fig. 5168.

MORRIS BOX-LIDS.

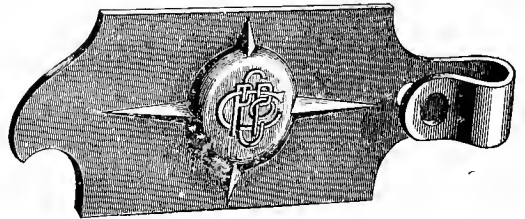

Fig. 5169.

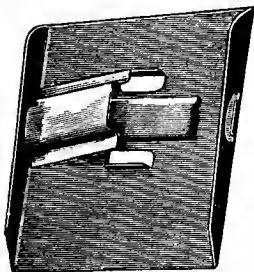

Fig. 5170.

THE HEWITT BOX-LID.
Made of Pressed Steel.

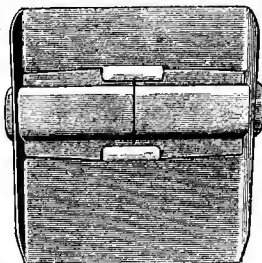
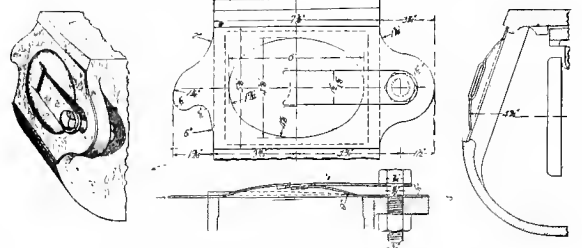

Fig. 5171.



Figs. 5172-5175.
THE DREXEL BOX-LID.

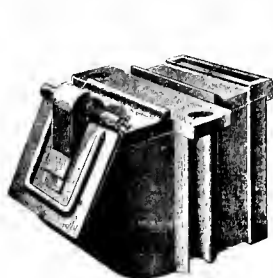
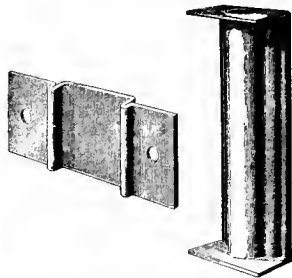
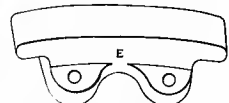
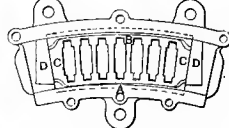

Fig. 5183. PRESSED-STEEL JOURNAL-BOX.



Figs. 5184-5185. PRESSED-STEEL BOLSTER-COLUMN AND GUIDE-PLATE.



Figs. 5187-5189. HUBBARD ANTI-FRICTION SIDE-BEARING.

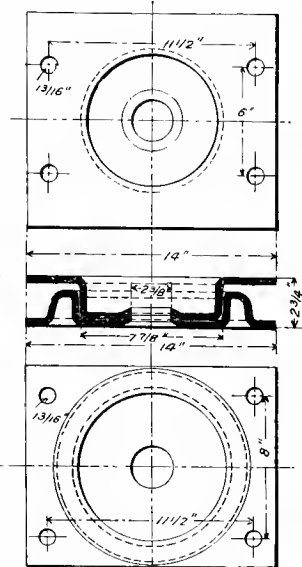

Figs. 5176-5178.

SCHOEN PRESSED-STEEL CENTER-PLATES.

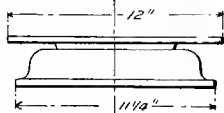
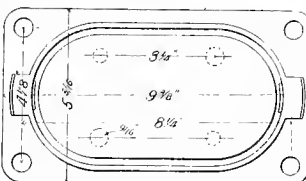
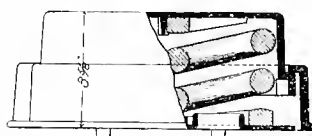

Fig. 5180.



Figs. 5190-5191. KING'S YIELDING SIDE-BEARING.



Figs. 5181-5182.



Schoen's Patents.

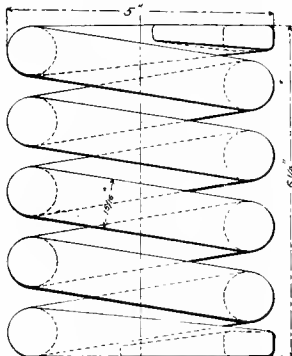
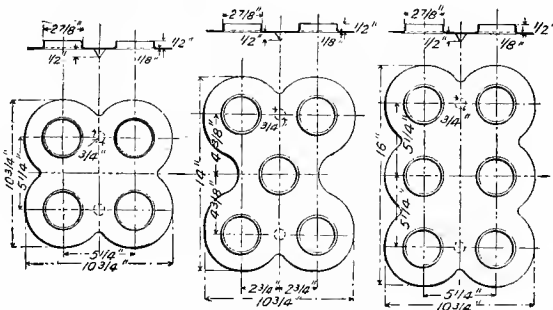

Fig. 5192.

BOLSTER-SPRING, SEATS AND CAPS. NORFOLK & WESTERN RAILROAD. The number of springs depends on capacity of car, each spring being capable of carrying about 10,000 lbs.



Figs. 5193-5198.



Figs. 5185-5186. THE SCHOEN PRESSED-STEEL BRAKE-SHOE.

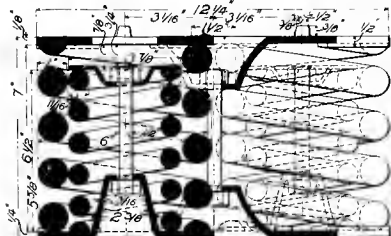

Figs. 5199-5200.

FREIGHT BOLSTER-SPRING AND CASE. L. S. & M. S. RAILWAY.

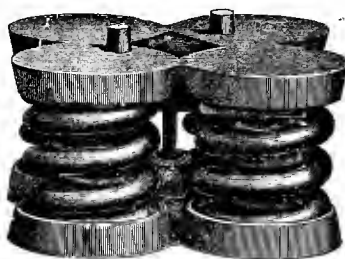

Figs. 5201-5202. BOLSTER-SPRING. Four springs in groups of 3 coils or less, as required.

Width of Case, 11 ins. Capacity, 5 to 8 tons.



Figs. 5203-5204. BOLSTER-SPRING. Four single-coil springs.

Diameter of Case, 11 ins. Height, 7 ins. Capacity, 6 to 8 tons. (352)

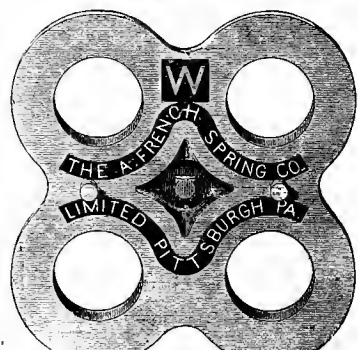
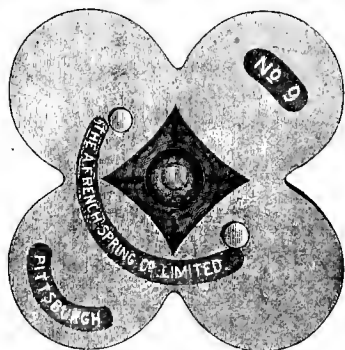
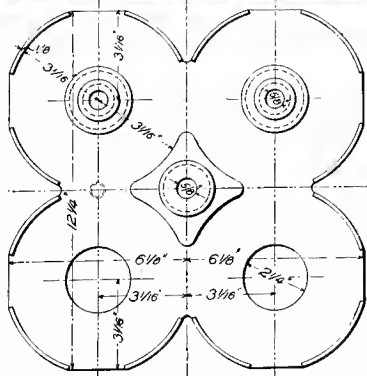

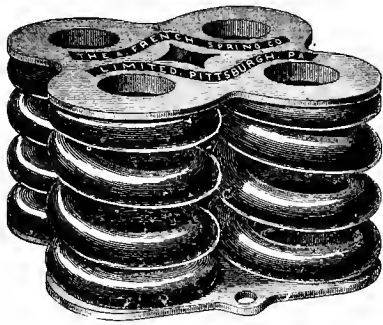

Fig. 5205.
BOLSTER-SPRING.
Four single-coil springs. Diameter of case, 11 ins. Height, 6 ins. Capacity, 6 to 8 tons.

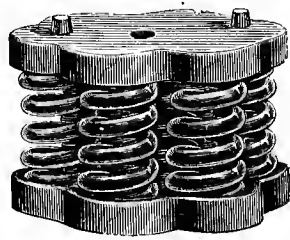

Fig. 5206.
BOLSTER-SPRING.
Seven coil. Round bar.



Fig. 5207.
BOLSTER-SPRING.
Four-coil. Capacity, 6 to 8 tons.

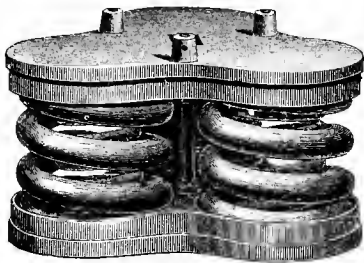

Fig. 5208.
Three double-coil springs. Diameter of case, 13 ins. Capacity, 5 to 6 tons.

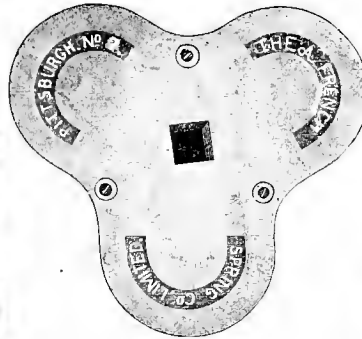

Fig. 5209.
Spring-plate.

BOLSTER-SPRINGS AND CASE.

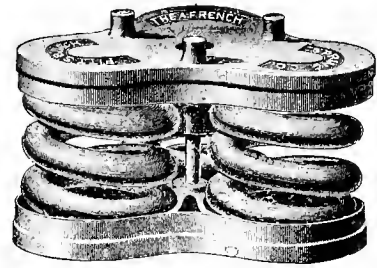

Fig. 5210.
Three single-coils. Diameter of case, 11 ins. Capacity, 5 to 6 tons.

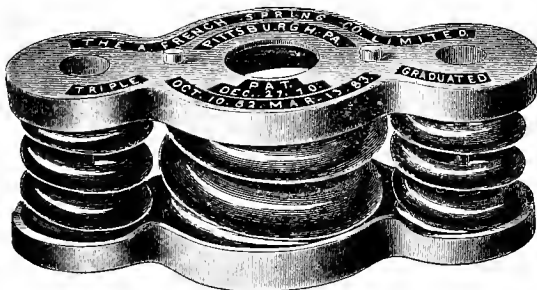

Fig. 5211.

TRIPLE GRADUATED BOLSTER-SPRING.

The large spring carries empty car-body; the smaller springs assist in carrying the load.



Fig. 5212.

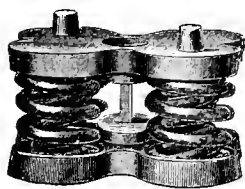

Fig. 5213.

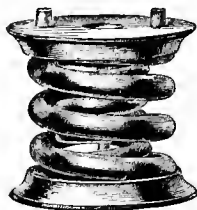

Fig. 5215.

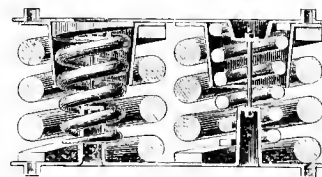

Fig. 5218. GRADUATED TWO-GROUP BOLSTER-SPRING.

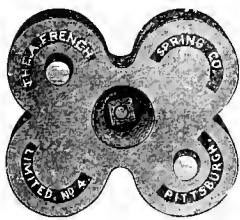

Fig. 5214.
NARROW-GAGE BOLSTER-SPRING.
Width of ease, 7 ins. Four two-coil springs. Capacity, 2 tons.

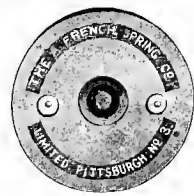

Fig. 5216.
NARROW-GAGE BOLSTER-SPRING.
Diameter of case, 7 ins. Capacity, 2 1/2 tons.

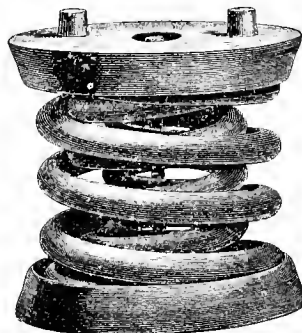

Fig. 5218a.



Fig. 5218b.
CABOOSE BOLSTER-SPRING.
Three-coil. Diameter of case, 9 1/2 ins.

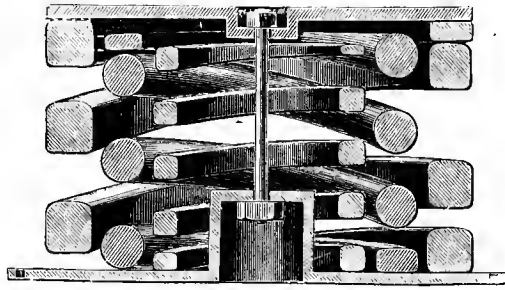

Fig. 5219.
TRIPLE-COIL GRADUATED BOLSTER-SPRING.

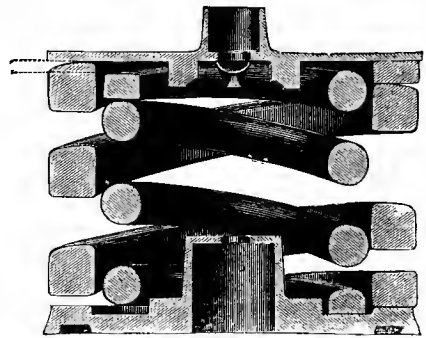

Fig. 5220.
DOUBLE-COIL GRADUATED BOLSTER-SPRING.



Fig. 5221.

BOLSTER-SPRING OF 8 SINGLE COILS.
Width of Case, 7½ ins. Capacity, 5 to 6 tons.



Fig. 5222.



Fig. 5223.
DOUBLE-COIL
EQUALIZER-SPRING.



Fig. 5224.
DOUBLE-COIL
EQUALIZER-SPRING.



Fig. 5225.
TRIPLE-COIL
EQUALIZER-SPRING.



Fig. 5226.
SINGLE-COIL
EQUALIZER-SPRING.

3. Spring-seat. 4. Spring-cap.

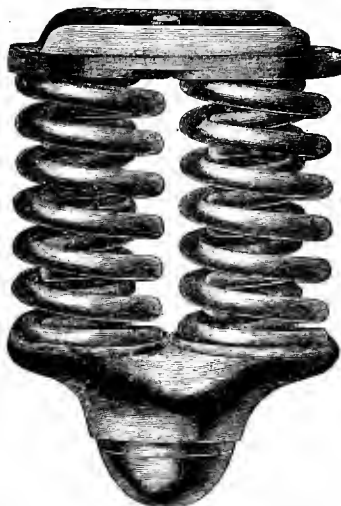

Fig. 5227.
DOUBLE-COIL EQUALIZER-SPRING.



Fig. 5228.
TRIPLE-COIL EQUALIZER-SPRING.

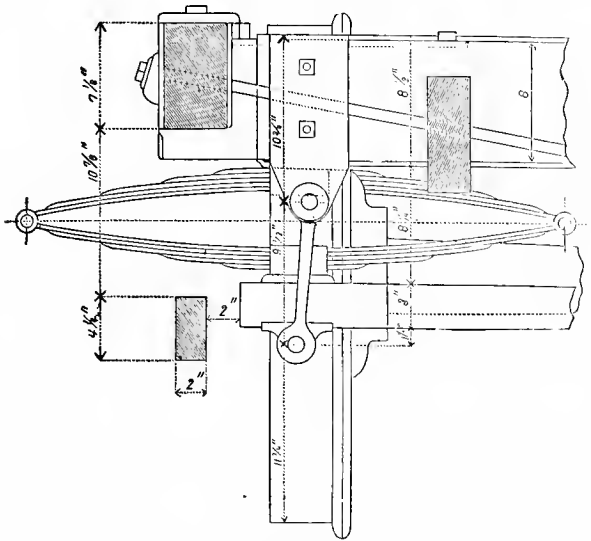

Fig. 5229.
APPLICATION OF ELLIPTIC-SPRINGS TO A COACH,
(Other ways are shown under Trucks.)

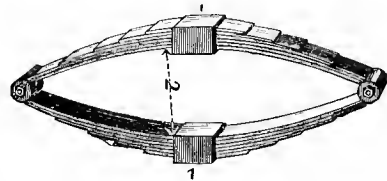

Fig. 5230. ELLIPTIC-SPRING.

- 1. Spring-band.
 - 2. Set, of Spring.
 - 3. Scroll.
 - 4. Eye-bolt.
- Length is understood to be from center to center of scrolls when unloaded.
— Arch is half the set.

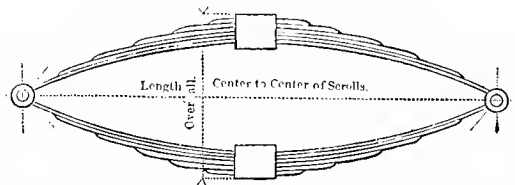

Fig. 5231.
DIAGRAM OF ELLIPTIC-SPRING,
Showing dimensions required by manufacturers.

In making Elliptic Springs for freight or passenger cars, the following information is required :

Length between centers of scrolls, light.....	Overall, loaded.....	Thickness of plates.....	Four or six-wheeled trucks.....
Number of plates.....	Total weight car body.....	Size of hands.....	Number of springs in bundle.....
Width of plates.....	Seating capacity.....	Overall, light.....	

Elliptic-springs are designated as *Duplicate, Triplet, Quadruple, Quintuple, Sextuple*, which include two, three, four, five and six full elliptic-springs bolted together.

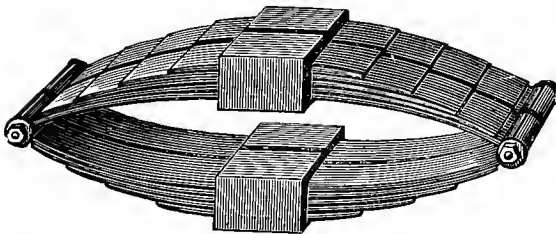

Fig. 5232. DOUBLE ELLIPTIC-SPRING,
for freight service.

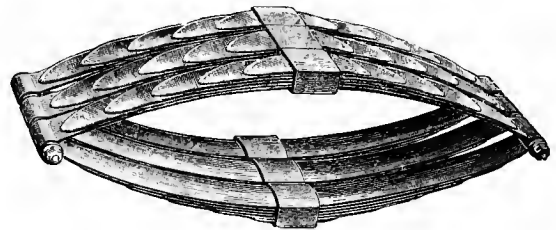

Fig. 5233. CONCAVE ELLIPTIC-SPRING.
(36 in. x 12 1/4 in. high, 6 leaves ; main, 3 x 1/4 in. ; others, 3 x 3-16 in. Weight, 183 lbs. Capacity, 9,500 lbs., half exhausted.)

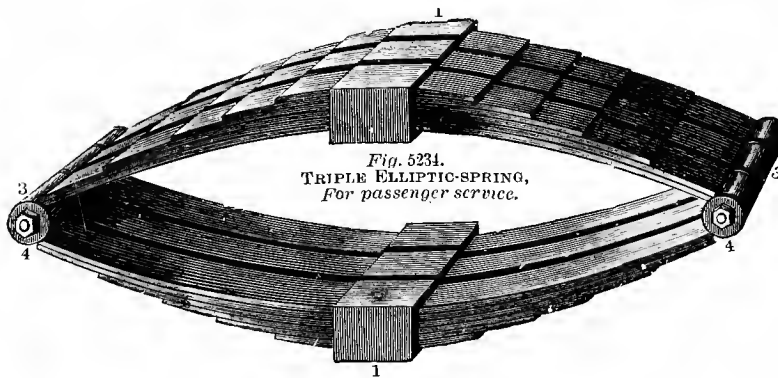

Fig. 5234.
TRIPLE ELLIPTIC-SPRING,
for passenger service.



Fig. 5235.
5 1/2 x 8 ins.



Fig. 5236.
5 3/4 x 6 ins.



Fig. 5237.
VALVE-SPRING.



Figs. 5238-5239.
MACHINERY-SPRINGS.



Fig. 5240.
DRAFT AND JOURNAL-
SPRING.



Fig. 5240a.
DIFFERENTIAL
SPIRAL-SPRING.
For various purposes

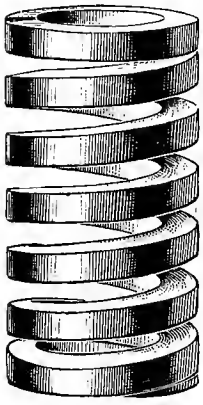

Fig. 5241.
SQUARE-BAR SINGLE-COIL
SPRING.



Fig. 5242.
KEG-SHAPED SPIRAL-SPRING.

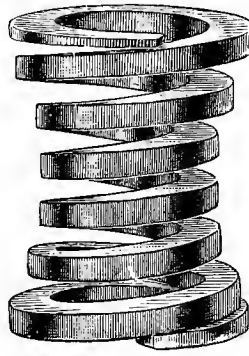

Fig. 5243.
SPOOL-SHAPED SPIRAL-SPRING.

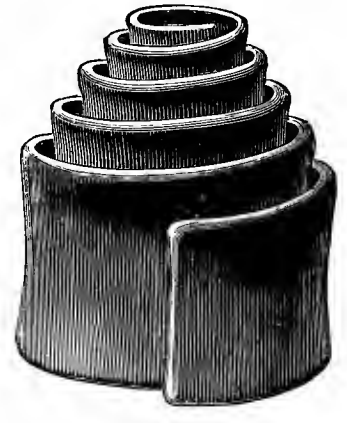

Fig. 5244.
VOLUTE-SPRING.



Fig. 5245.
OVAL-BAR DOUBLE-COIL BUFFER-
SPRING.



Fig. 5246.
ROUND-BAR TRIPLE COIL GRADUATED-SPRING.



Fig. 5247.
ROUND-BAR DOUBLE-COIL
BUFFER-SPRING.
(Capacity, 16,000 to 18,000 lbs.)

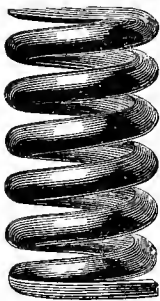

Fig. 5248.
ROUND-BAR SINGLE-COIL
SPIRAL-SPRING.



Fig. 5249.
ROUND BAR DOUBLE-COIL
SPIRAL-SPRING OR NEST-SPRING.



Fig. 5250.
ROUND-BAR TRIPLE-COIL
SPIRAL-SPRING OR NEST-SPRING.

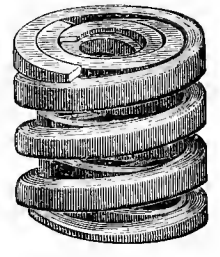

Fig. 5251.
SQUARE-BAR TRIPLE-COIL
NEST-SPRING.

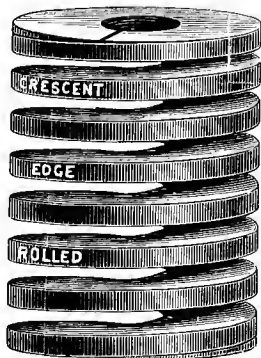

Fig. 5252.
EDGE-ROLLED SPIRAL-SPRING.

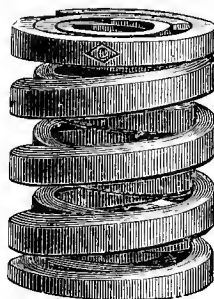

Fig. 5253.
FLAT-BAR OR EQUAL-BAR TRIPLE-COIL
SPIRAL-SPRING OR NEST-SPRING.

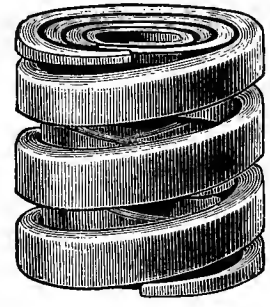
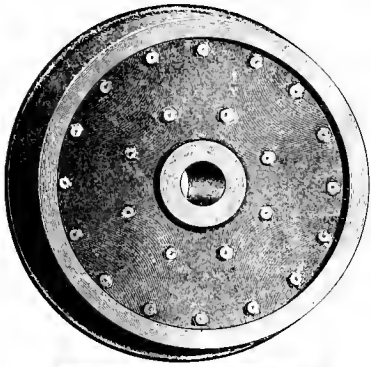
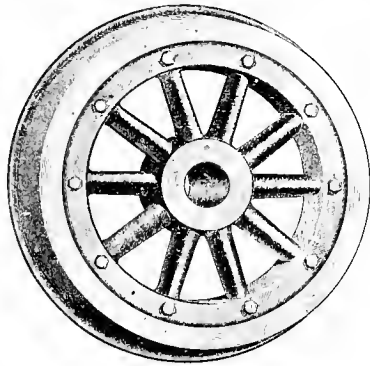

Fig. 5254.
"HIBBARD" OR FLAT-BAR
QUADRUPLE-COIL NEST-SPRING.



Figs. 5255-5256. No. 1. Wheel with Paper Center. Tire secured by Plates and Bolts.



Figs. 5257-5258. Cast-iron Spoke-center. Tire is Fastened with One Retaining-ring.

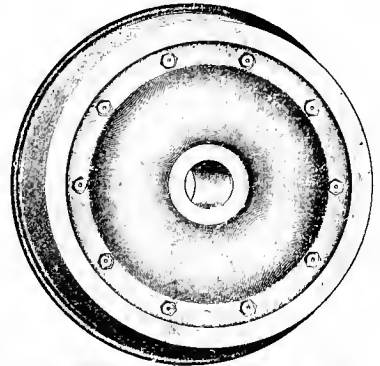

Figs. 5259-5260. No. 11. Wheel with Cast-iron Double-plate Center. Tire secured by One Retaining-ring.

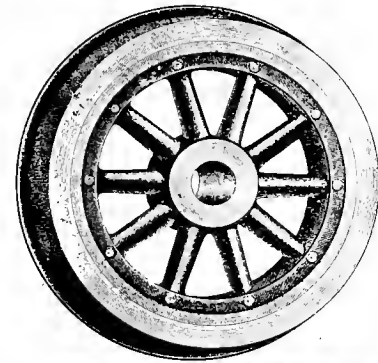
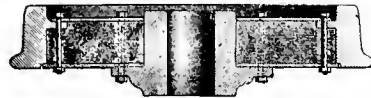

Figs. 5261-5262. No. 7. Wheel with Cast-iron Spoke-center. Tire secured by Mansell Retaining-rings.

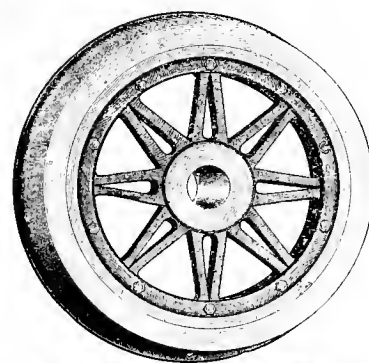

Figs. 5263-5264. No. 6. Wrought-iron Double-spoke Center. Tire is secured by Retaining-rings.

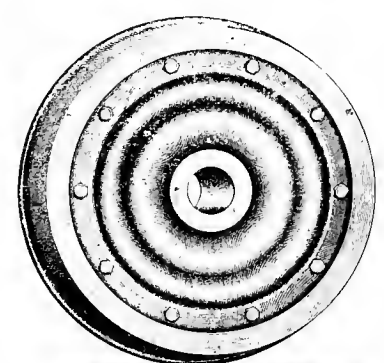

Figs. 5265-5266. No. 4. Wrought-iron Pressed-plate Center. Tire Shrunken on Center.



Fig. 5267. No. 5. Cross Section of Wrought-iron Pressed-plate Wheel.



Fig. 5268. No. 8. Cross Section of Cast-iron Double-plate Wheel.



Fig. 5269. No. 12. Cross Section of Cast-iron Spoke-wheel.

STEEL-TIRED CAR-WHEELS. ALLEN PAPER CAR WHEEL COMPANY.

Tires are shrunk on. Diameters are 26, 28, 30, 33, and 36 ins.

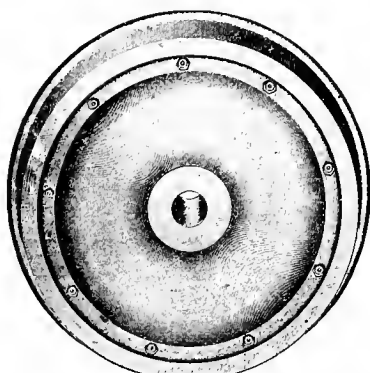

Figs. 5270-5271. Wheel with Cast-iron Double-plate Spoke-center.

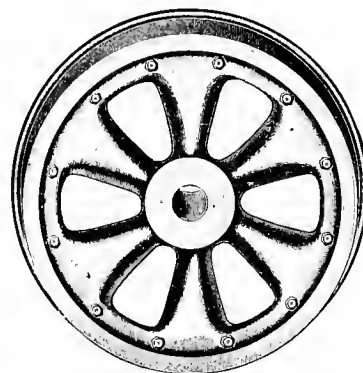

Figs. 5272-5273. Wheel with Cast-iron Spoke-center. Tire shrunk on Center.



WHEELS FOR ELECTRIC AND CABLE CARS. ALLEN PAPER CAR WHEEL COMPANY.

Steel Tired Wheels. Diameters, 28-33 ins.

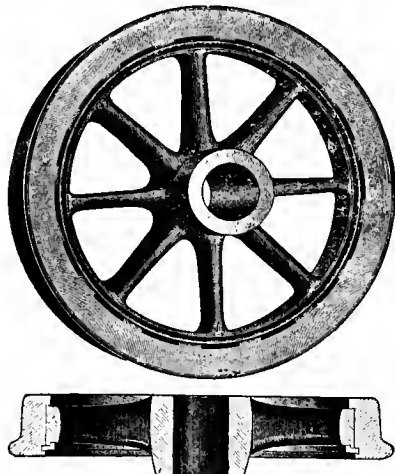

Figs. 5292-5293.
SOLID SINGLE-OVAL-SPOKE WHEEL.
Brunswick Tire-fastening.

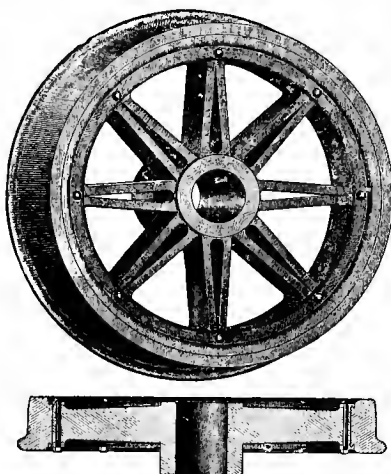

Figs. 5294-5295.
DOUBLE-SPOKE WHEEL.
Mansel Retaining-rings.

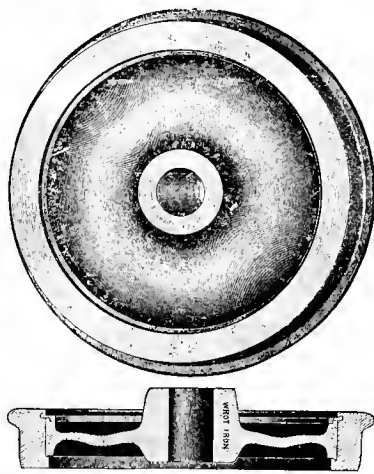

Figs. 5296-5297.
WROUGHT-IRON DISC CENTER WHEEL.
Brunswick Tire-fastenings.

WHEELS MADE BY PAGE, NEWELL & COMPANY, BOSTON.

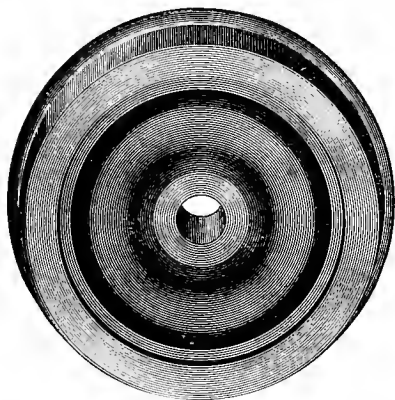

Figs. 5298-5299. NO. 14 WHEEL.
Wrought-iron Coil-disc Center. Tire Secured with Bute Fastening.

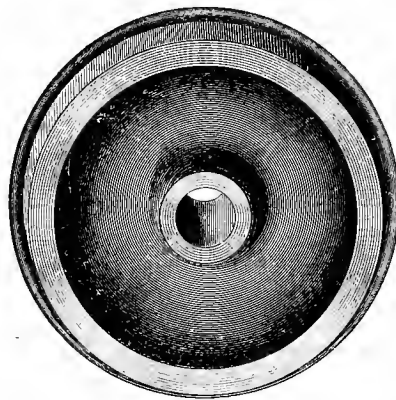

Figs. 5300-5301. NO. 13 WHEEL—PATENT SAFETY WHEEL.
Wrought-iron Coil disc Center. Tire Secured with Safety Lock.

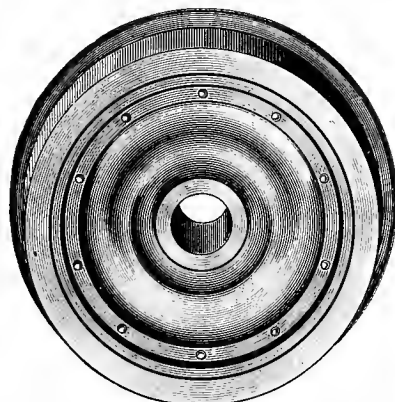

Figs. 5302-5303. NO. 1 WHEEL.
*Wrought-iron Coil-disc Centre.
Tire Secured by Wrought-iron Retaining-rings.*

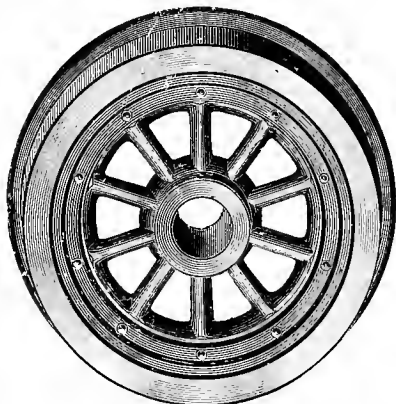

Figs. 5304-5305. NO. 3 WHEEL.
*Cast-iron Spoke Center.
Tire Secured by Wrought-iron Retaining-rings.*



KRUPP'S PATENT STEEL-TIRED WHEELS. THOMAS PROSSER & SON.

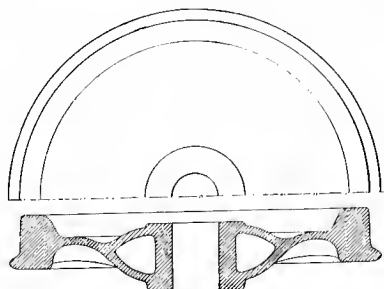

Figs. 5306-5306a.
CAST-IRON DOUBLE-PLATE CENTER WHEEL.
Center is cast into heated tire.

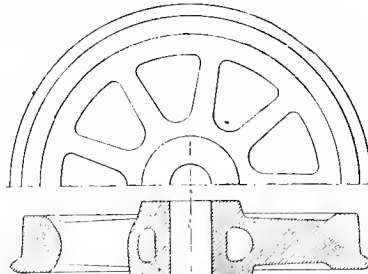

Figs. 5307-5307a.
CAST-IRON SPOKE CENTER-WHEEL.
Center is cast into heated tire.

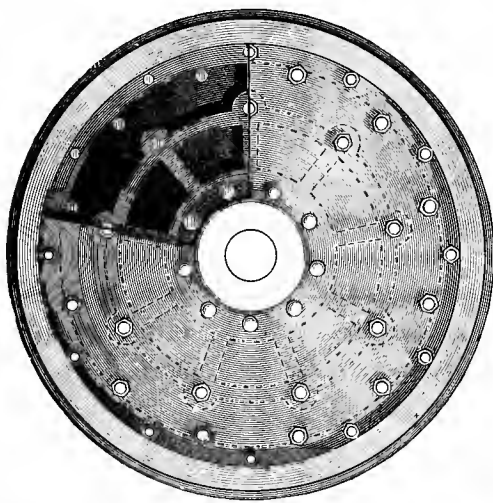

Figs. 5308-5309. Plate-wheel with Cast-iron Hub.

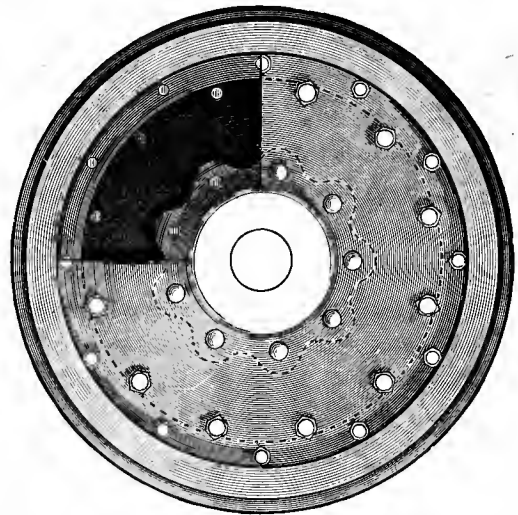

Figs. 5310-5311. Plate-wheel with Cast-iron Hub.

Tire is secured by two side-plates of $\frac{1}{2}$ -in. Steel, and bolted with Turned Steel Bolts.

WHEELS MADE BY THE PAIGE CAR WHEEL COMPANY.

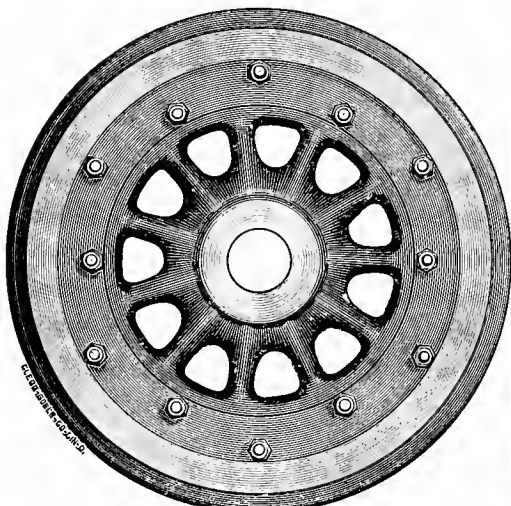

Figs. 5312-5213. Wheel for Engine-truck. Cast-iron Spoke-center.
Tire secured by a Steel Retaining-ring.
PAIGE CAR WHEEL COMPANY.

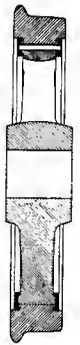
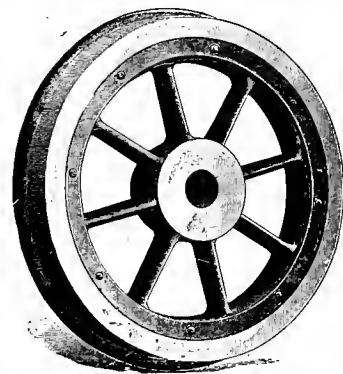

Figs. 5314-5315. VAUCRAIN STEEL-TIRED, WROUGHT-IRON SPOKE-CENTER WHEEL.
STANDARD STEEL WORKS, PHILADELPHIA.

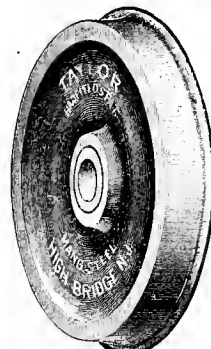
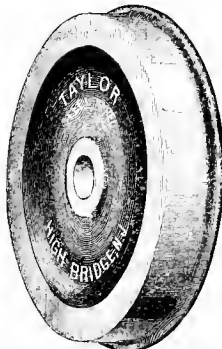

Figs. 5316-5317. TAYLOR'S INTERLOCKED AND WELDED STEEL-TIRED WHEEL.
The Steel Tire and Iron Center are Welded Together.

Figs. 5318-5319. TAYLOR'S MANGANESE STEEL WHEEL.
Water-toughened.



Fig. 5320. TEAK-WOOD-CENTER WHEEL.
Tire fastened with Mansell Rings.
Largely in use in England.

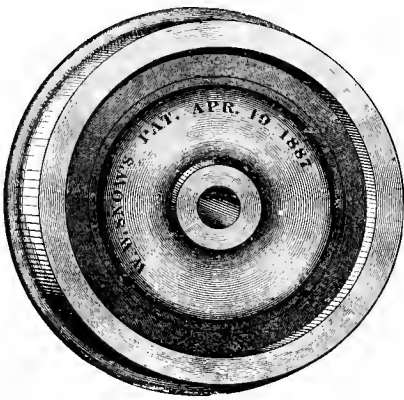
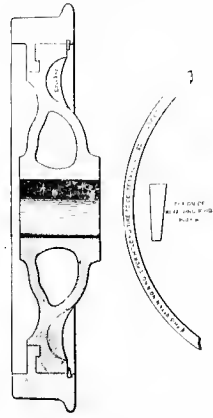

Fig. 5321.



Figs. 5322-24.

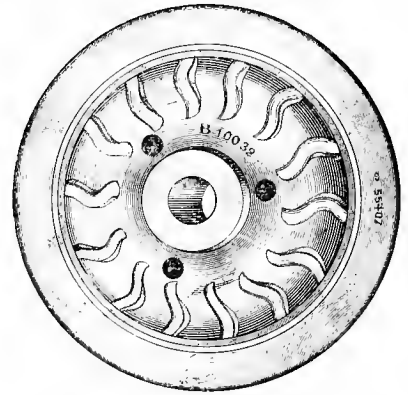

Fig. 5325.

SNOW'S BOLTLESS STEEL-TIRED DOUBLE-PLATE WHEEL.
Tire is fastened to center by retaining-ring.

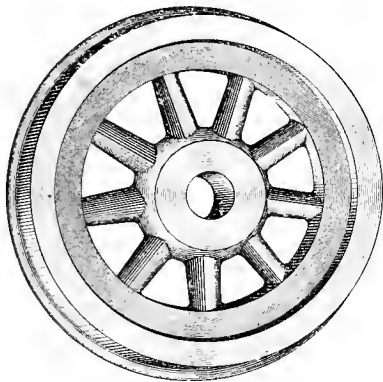

Fig. 5326.

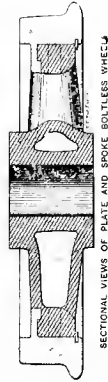

Fig. 5327.

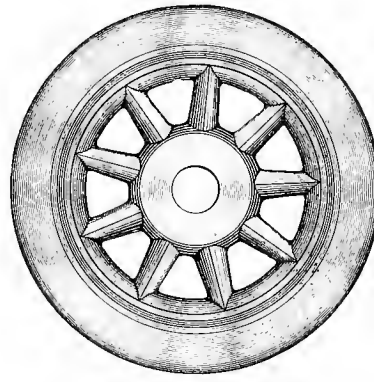
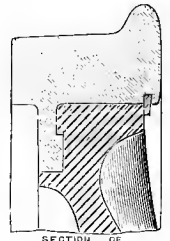
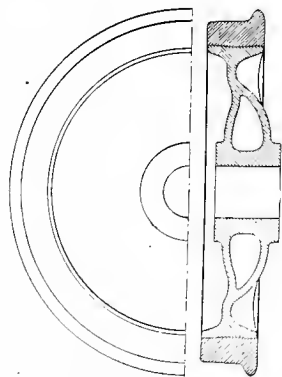

Fig. 5328.

SNOW'S BOLTLESS STEEL-TIRED SPOKE WHEEL.
Tire is fastened to center by retaining-ring.



SECTION OF
BOLTLESS FASTENING
Fig. 5329.
Section of Boltless
Fastening.



Figs. 5330-5331.

CAST-IRON DOUBLE-PLATE
CENTER.



Fig. 5332.

HOLLOW-SPOKE CAST WHEEL.
Center is cast into heated tire.

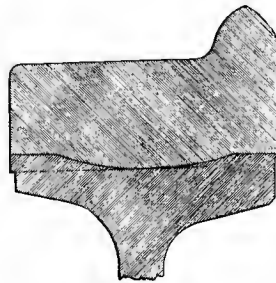

Fig. 5331.
Cross Section of Tread and
Flange, Chilled Wheel.

WASHBURN CAR WHEEL COMPANY.



Fig. 5335.



Figs. 5337-5338. CHILLED CAST WHEEL,
With curved ribs or brackets.

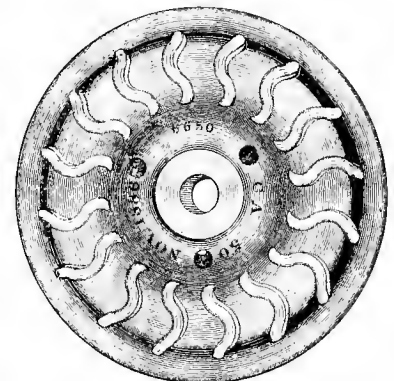

Fig. 5336. CHILLED CAST WHEEL,
With curved ribs or brackets.

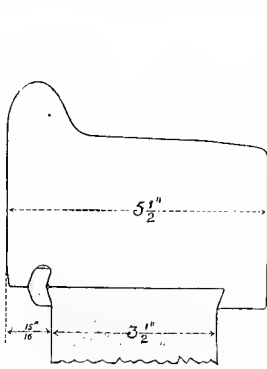

Fig. 5337.
THE GIBSON TIRE FASTENING.

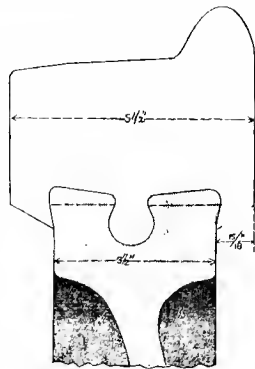

Fig. 5338.
THE KRUPP SAFETY-LOCK.

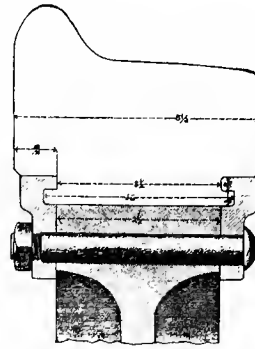

Fig. 5339.
THE MANSELL TIRE FASTENING
Fastenings for Steel-tired Wheels in General Use.

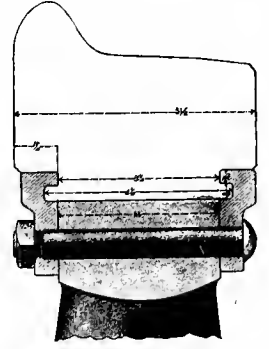

Fig. 5340.
THE MANSELL TIRE FASTENING.

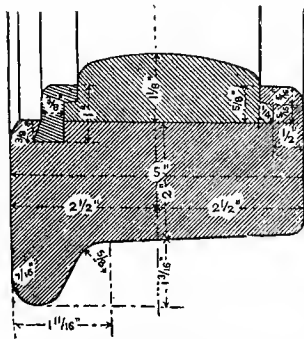

Fig. 5341.
THE GIBSON FASTENING

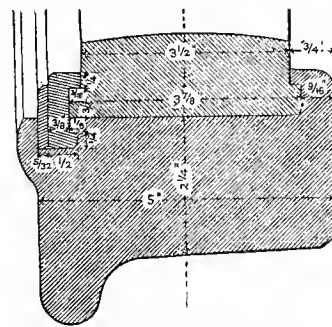

Fig. 5342.
CARLTON AND SPROUDELEY.
Fastenings that have been in use in Europe.

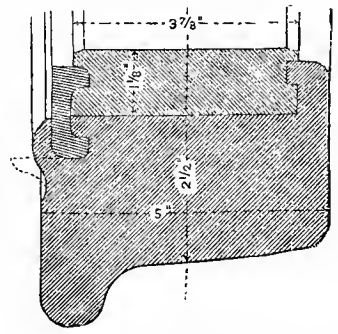

Fig. 5343
DRUMMOND FASTENING.

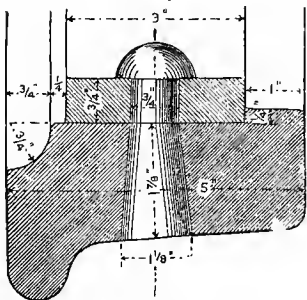

Fig. 5344.
RIVET FASTENING.

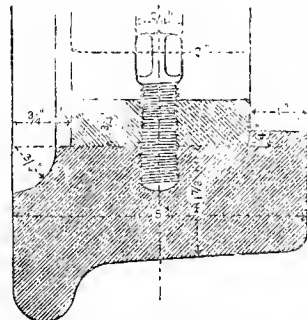

Fig. 5345.
SET-SCREW OR STUD FASTENING.
Fastenings that have been in use in Europe.

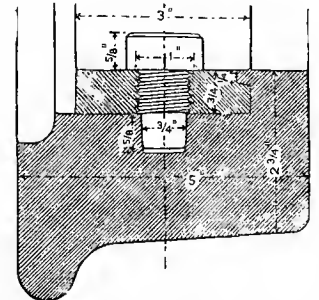

Fig. 5346.
SET-SCREW FASTENING (PLAIN END.)

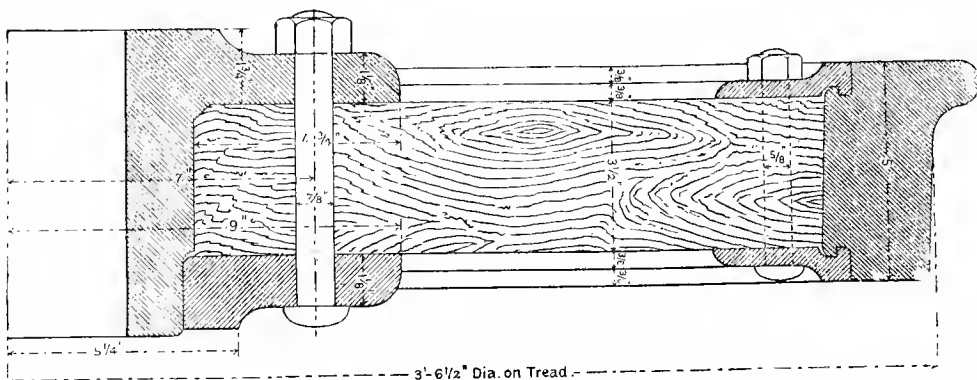
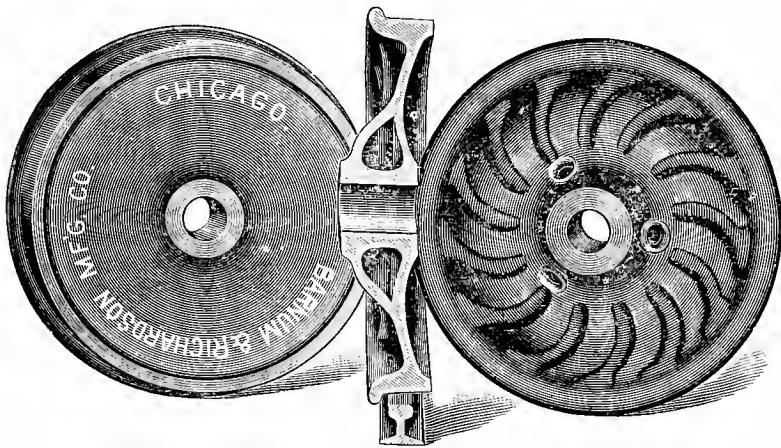
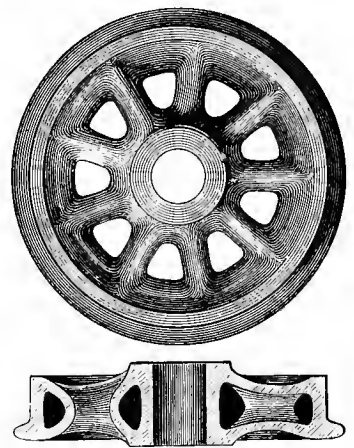

Fig. 5347. ENGLISH MANSELL WHEEL.
Teakwood Center. Tire secured by Mansell Retaining-rings.



Figs. 5348-50.

DOUBLE-PLATE CHILLED CAR-WHEELS.



Figs. 5351-52.

Section and Front View.
HOLLOW-SPOKE WHEEL.



Figs. 5353-54.

CAST-CENTERS FOR STEEL TIRES.

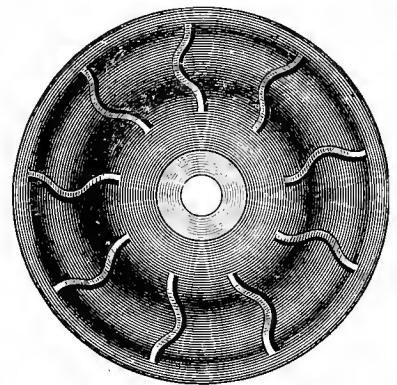

Figs. 5355-56.

Section and Back View.
SINGLE-PLATE WHEEL.

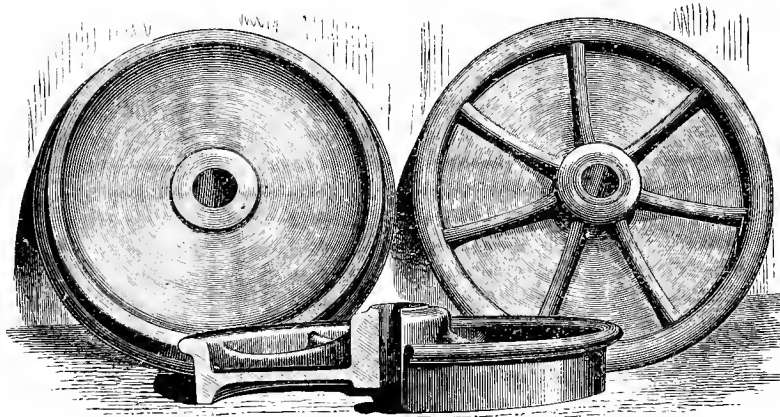

Back View.

Figs. 5357-59.

Front View.

SINGLE-PLATE WHEELS.

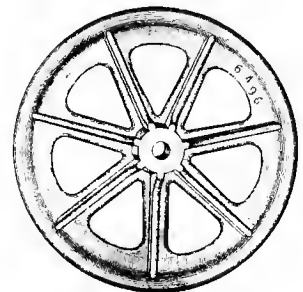

Fig. 5362. Back View.

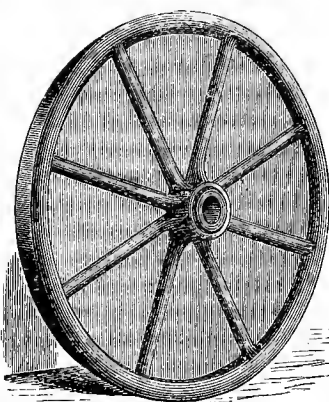

Fig. 5360. Back View.

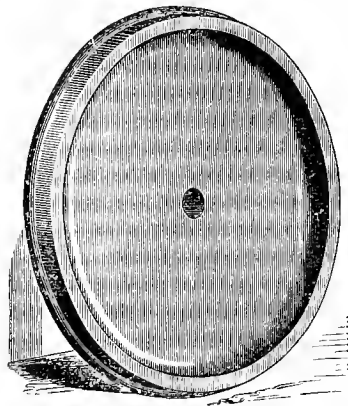

Fig. 5361. Front View.

SINGLE-PLATE WHEEL FOR STREET-CARS.

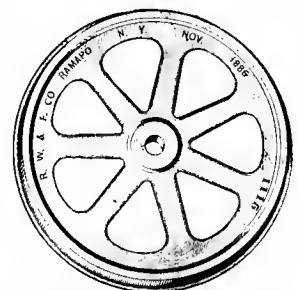

Fig. 5363. Front View.

OPEN-PLATE WHEEL FOR STREET-CARS.



Fig. 5374. Elevation.

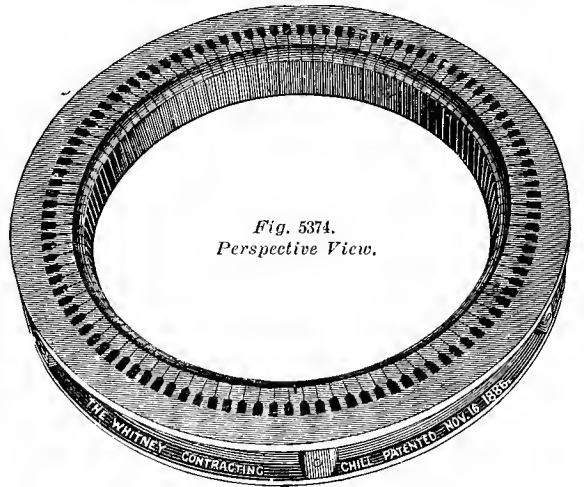

Fig. 5374. Perspective View.

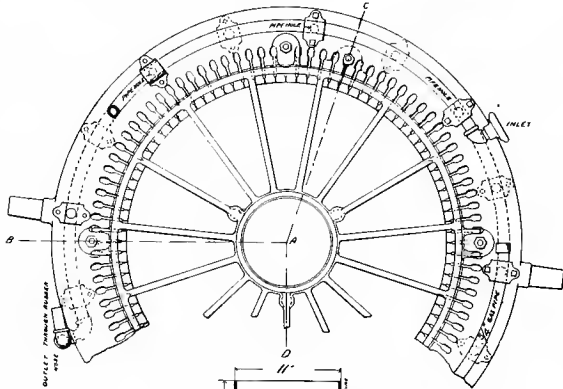

Fig. 5365. Plan.

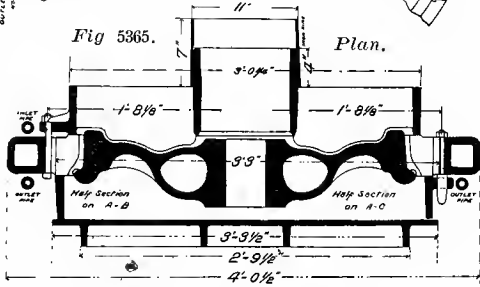

Fig. 5366. Half Cross Sections.

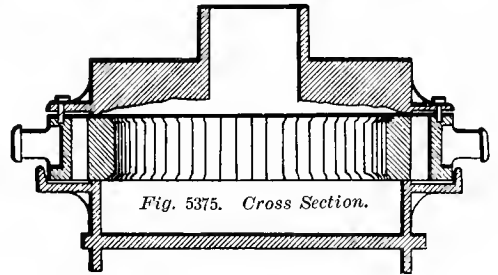

Fig. 5375. Cross Section.

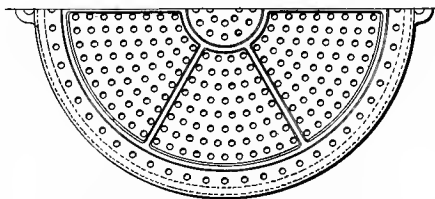

Fig. 5367. Plan of Bed Plate.
THE BARR CONTRACTING-CHILL.

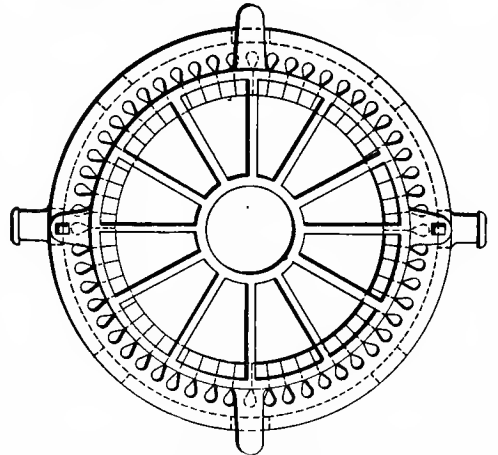

Fig. 5376. Plan.
THE WHITNEY CONTRACTING-CHILL.

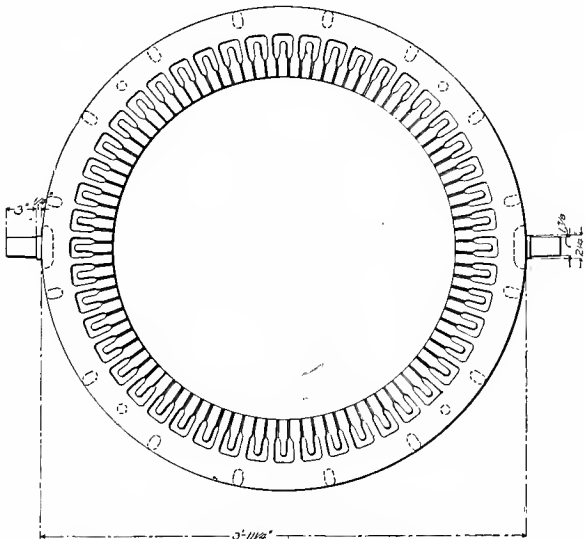

Fig. 5363. Plan of Chill.

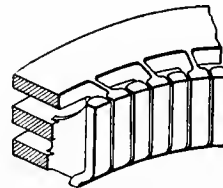
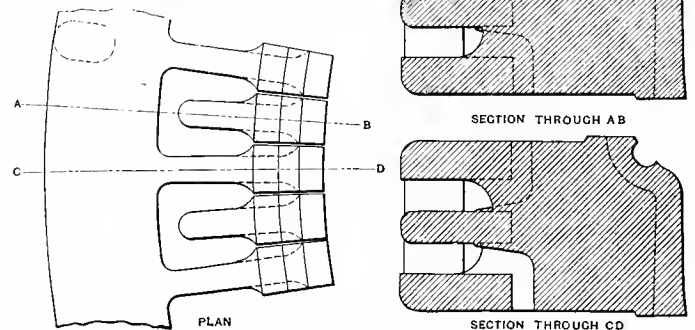

Fig. 5370. Perspective View of Segmental Chilling-blocks.



Fig. 5369.
Half Cross Section and Half Side Elevation.



Figs. 5371-5373.
Enlarged Plan and Cross Sections of Segmental Chilling-blocks.

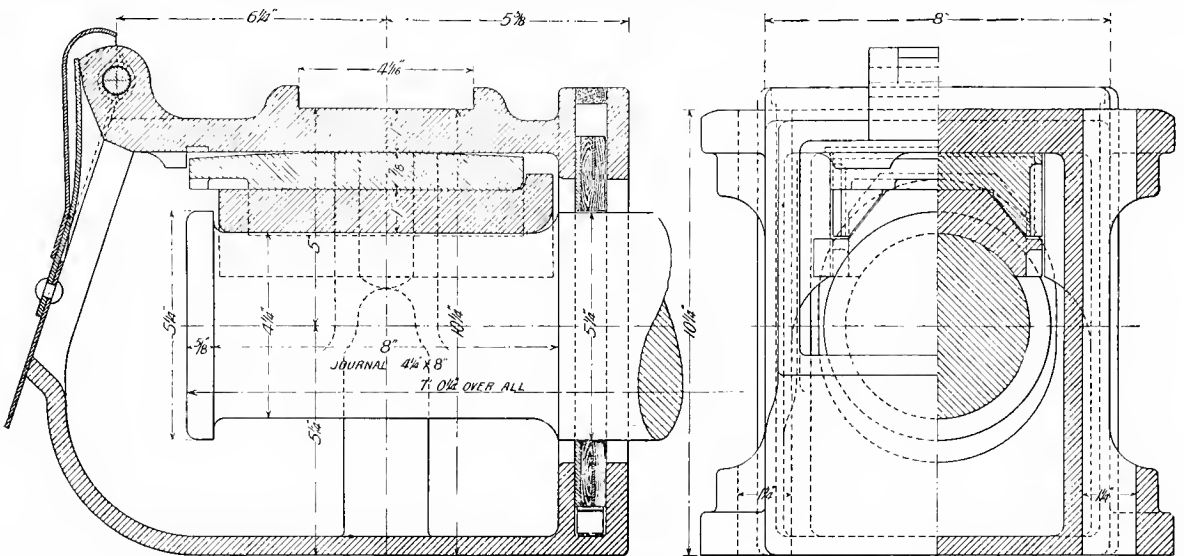

Fig. 5383. Longitudinal Section.

6.3" CENTRE TO CENTRE.

Fig. 5385. Half End Elevation and Half Cross Section.

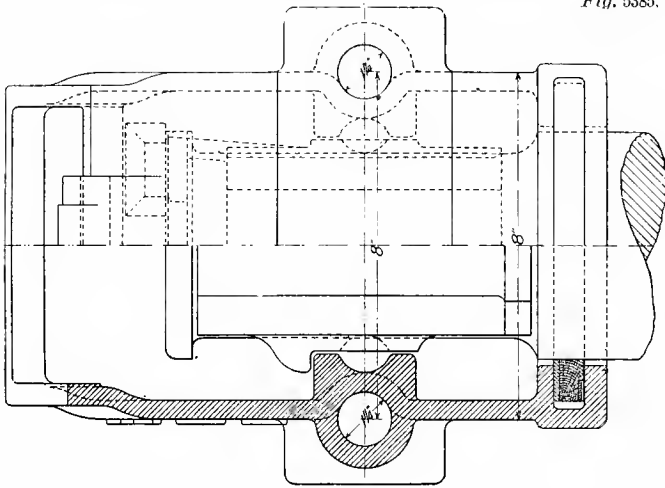

Fig. 5384. Half Plan and Half Longitudinal Section.

NOTE.—If the method of molding does not permit of placing the letters M. C. B. on the side of the journal-box, they may be placed on the top, between the hinge-lug and the arch-bar seat.

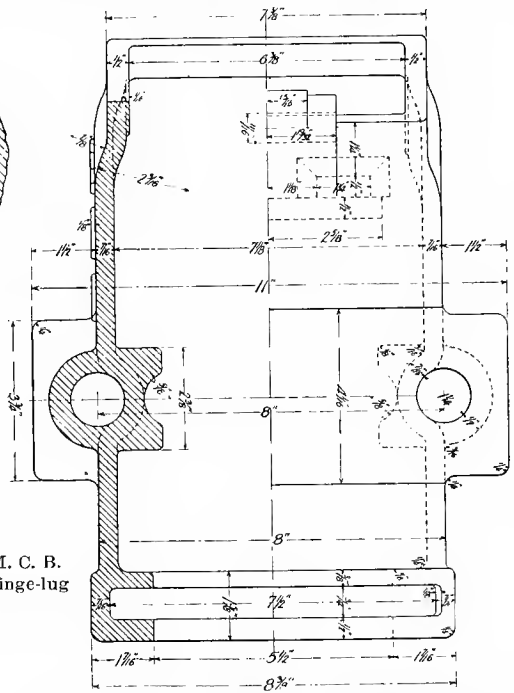

Fig. 5388.

Half Plan and Half Longitudinal Section.

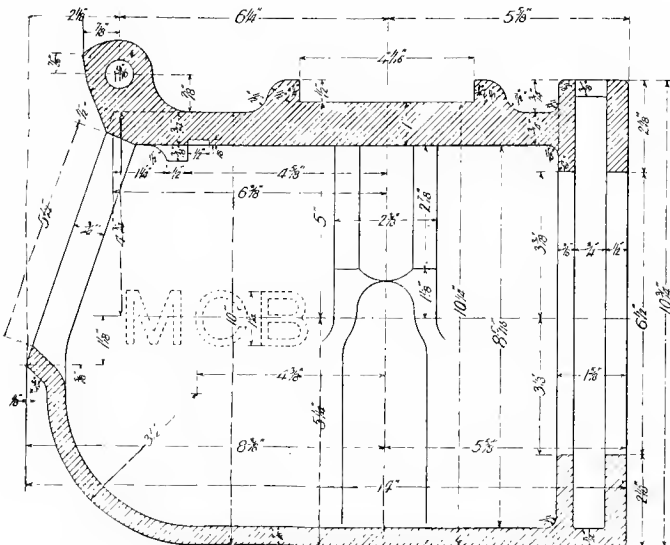

Fig. 5386. Longitudinal Section.

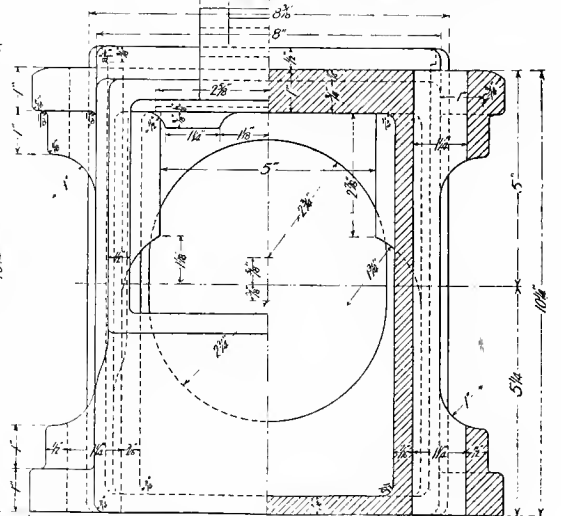
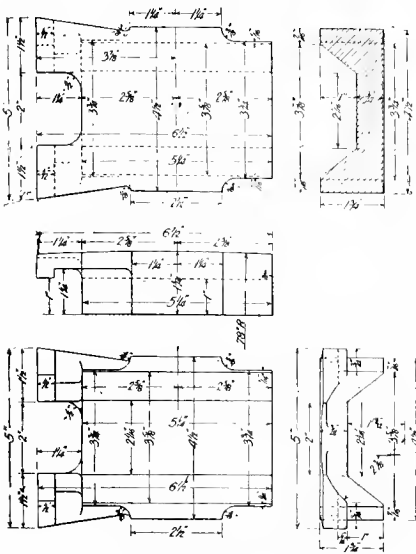
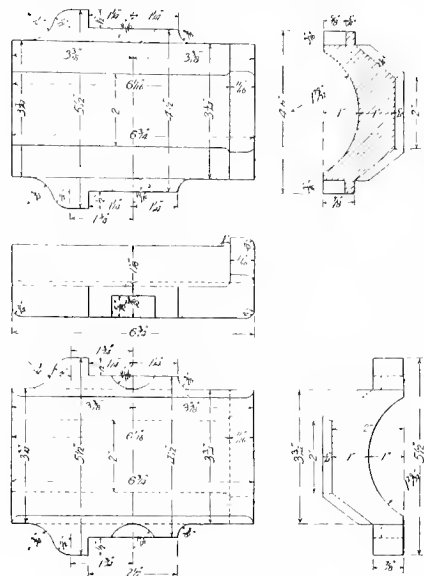

Fig. 5387. Half End Elevation and Half Cross Section.

MASTER CAR BUILDERS' STANDARD JOURNAL BOX AND CONTAINED PARTS FOR A 1 1/4 x 8 IN. JOURNAL.
(Adopted as standards in 1893.)



Figs. 5389-5393. WEDGE.



Figs. 5394-5398. BEARING.

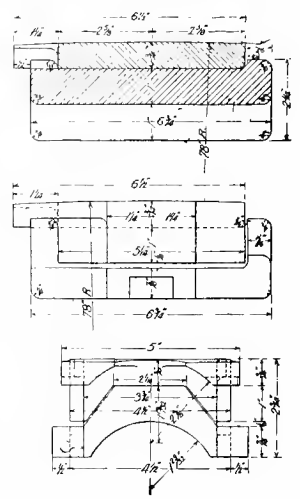

Figs. 5399-5401. WEDGE AND BEARING.

STANDARD WEDGE AND BEARING FOR 3 3/4 7-IN. JOURNAL.
Adopted in 1893 and revised in 1894.

NOTE.—The journal-box and details as shown in these drawings were adopted as standards of the Association, by letter ballot, in 1893, and revised in 1894. For former action, see Proceedings 1874, page 49; Proceedings 1881, pages 14, 15 and 27.

The revision made in 1894 consisted in correcting the drawing at the top of the journal-box, and in leaving off the lugs at sides of arch-bars; also in changing the wedge and bearing of the 3 3/4 x 7 in. journal so as to make the latter flat on top instead of curved, as theretofore, and in curving the top of the wedge, thus making this construction similar in general arrangement to the standard forms for the 4 1/4 x 8 in. journal-box.

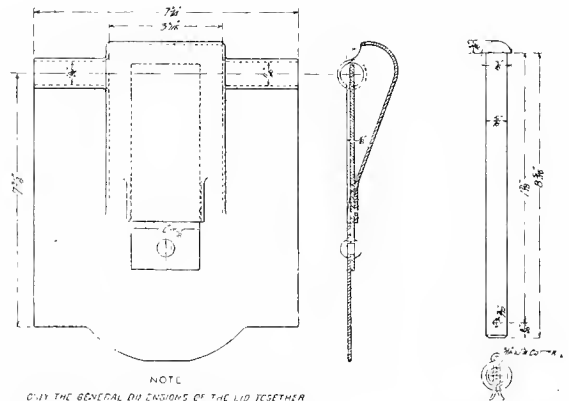

NOTE
GIVE THE GENERAL DIMENSIONS OF THE LID TOGETHER WITH THE DIAMETER OF THE HOLE FOR NUTS. THE LID MAY BE OF ANY MATERIAL PROVIDED IT IS HARD ENOUGH.

Figs. 5402-5405.

STANDARD BOX-LID FOR 3 3/4 x 7 AND 4 1/4 x 8-IN. JOURNAL-BOXES.
Adopted in 1891 and 1893.

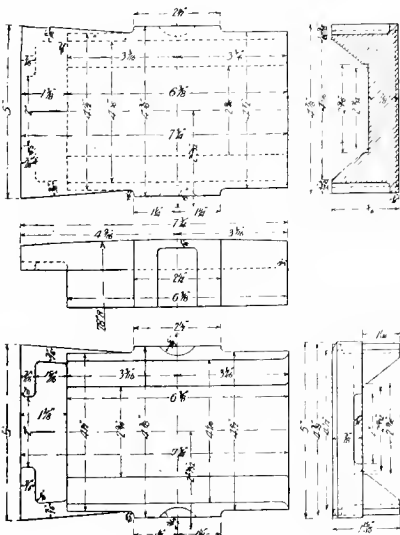

Figs. 5406-5410. WEDGE.

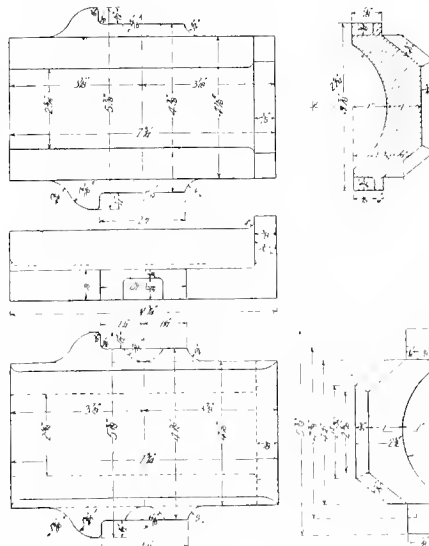

Figs. 5411-5415. BEARING.

STANDARD WEDGE AND BEARING FOR 1 1/4 x 8-IN. JOURNAL.
Adopted in 1893.

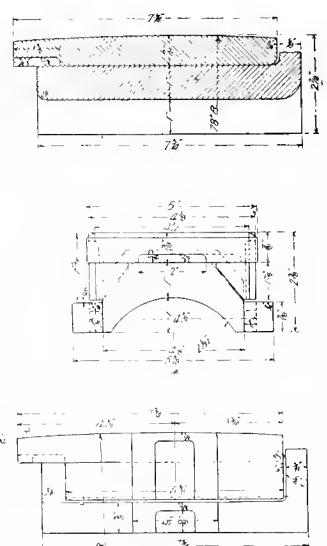

Figs. 5416-5418. WEDGE AND BEARING.

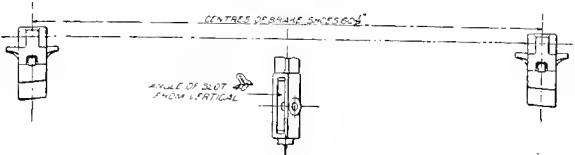
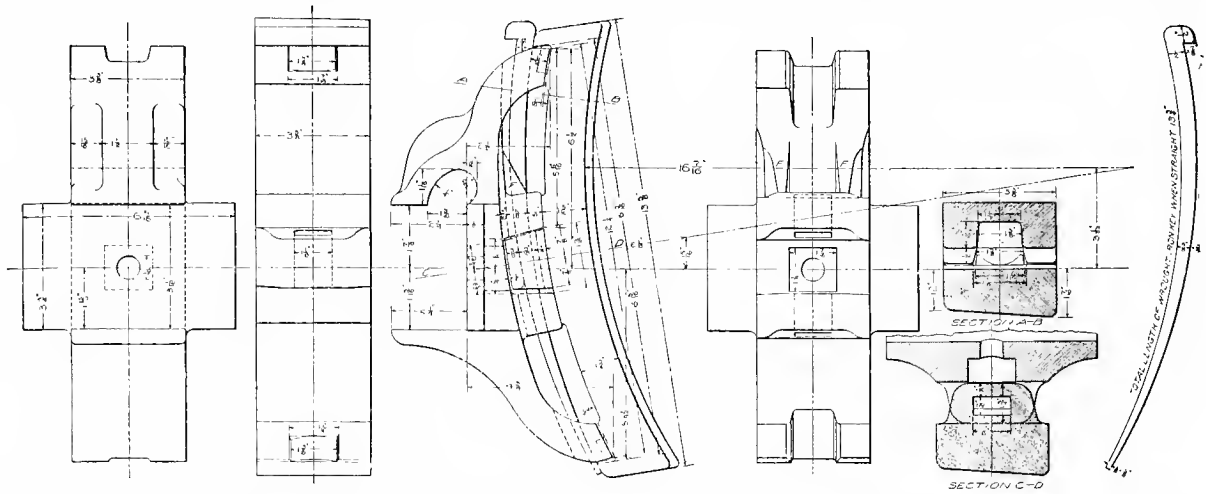
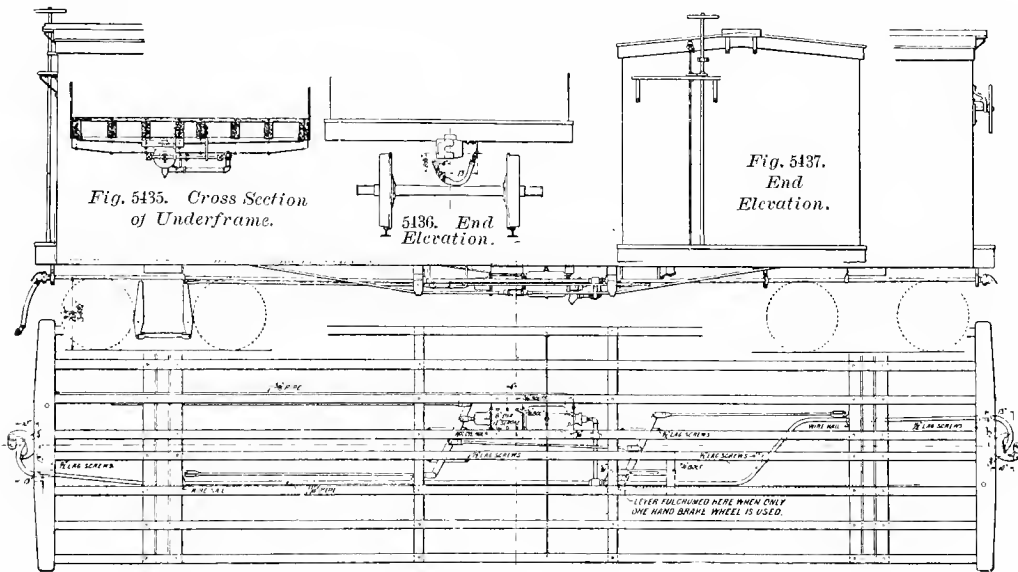

Fig. 5432. STANDARD DATA FOR IRON BRAKE-BEAM.



Figs. 5433-31. Elevation and Plan. STANDARD AIR-BRAKE GEAR FOR FREIGHT-CARS.

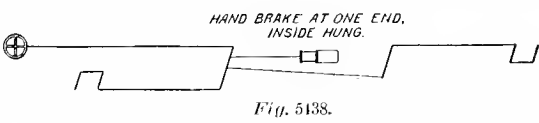

Fig. 5438.

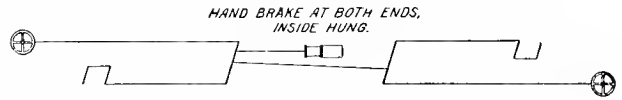

Fig. 5439.

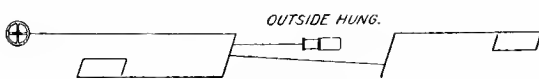

Fig. 5440.

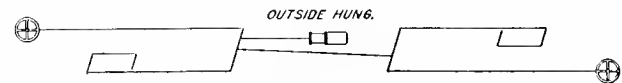
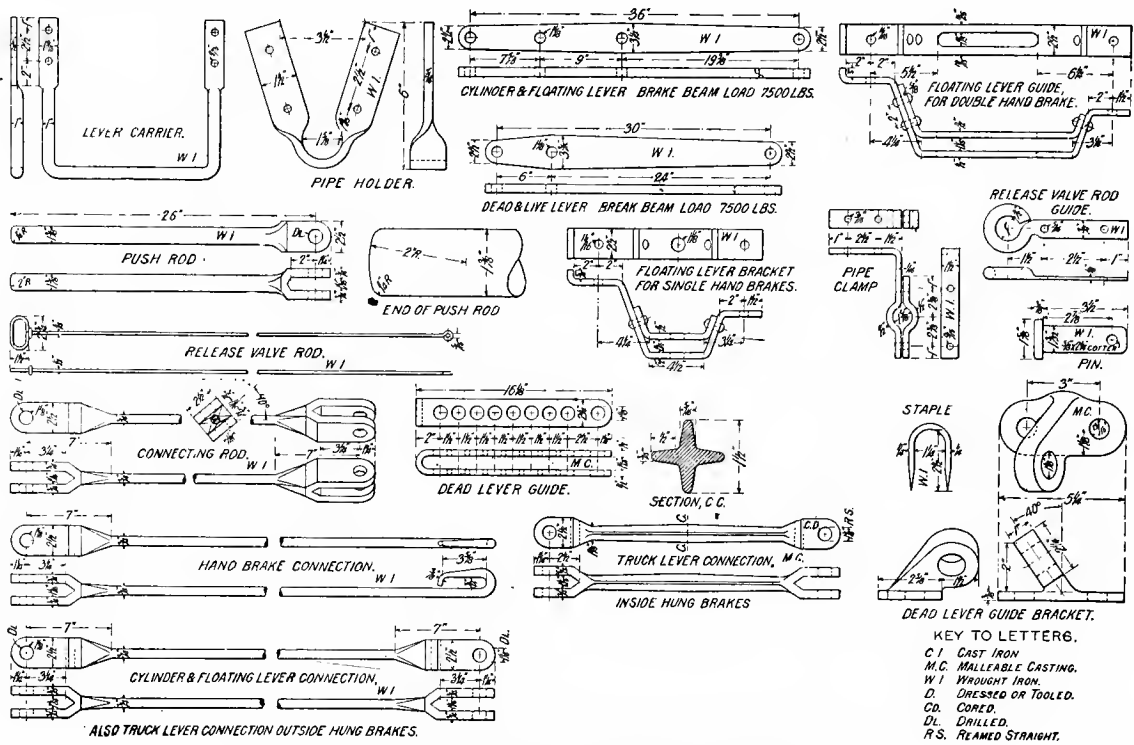

Fig. 5441.

GENERAL ARRANGEMENT OF LEVERS AND CONNECTIONS OF BRAKE-GEAR FOR FREIGHT-CARS.

- Adopted by letter ballot, 1889, subsequent actions in 1890, 1891 and 1893. The following data are also standard :
1. Maximum train-pipe pressure, 70 lbs. per square inch.
 2. Maximum braking power in freight cars, 70 per cent. of the light weight of car.
 3. All levers 1 inch in thickness; all pins turned to 1 3-32 inches in diameter; all jaws and clevises made of ¾ in. - 2½ in. iron; all rods ¾ in. diameter.
 4. Angle of brake-beam lever, 40° with vertical.
- The general arrangement is also shown under Car-body Details, Brake-gear, Figs 1457-1527 and 1695-1693.



Figs. 5442-5479. DETAILS OF FOUNDATION BRAKE-GEAR FOR FREIGHT-CARS. Adopted as Standard 1889; revised in 1890, 1891 and 1893.

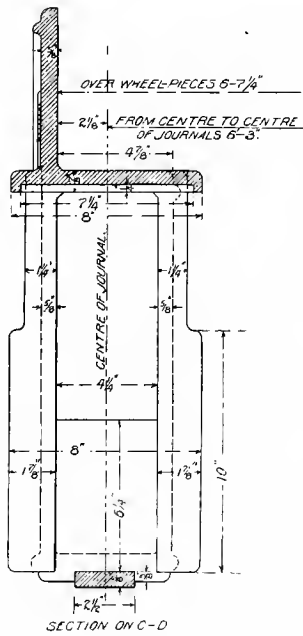

Fig. 5480. Cross Section.

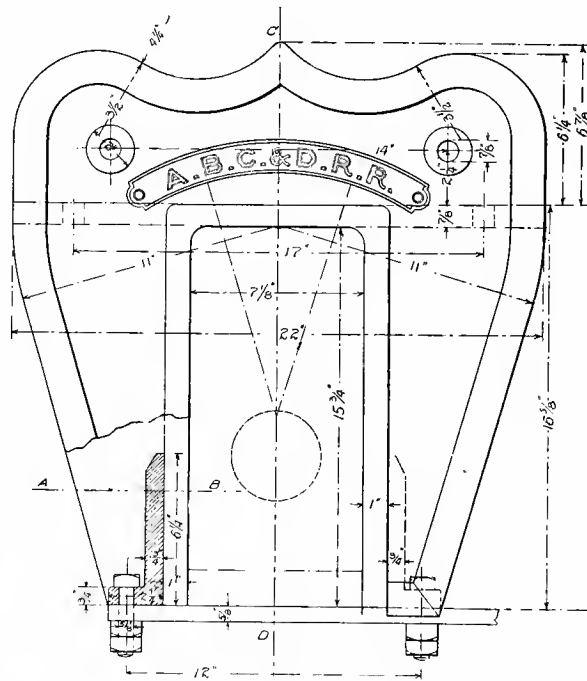

Fig. 5481. Sectional Elevation.

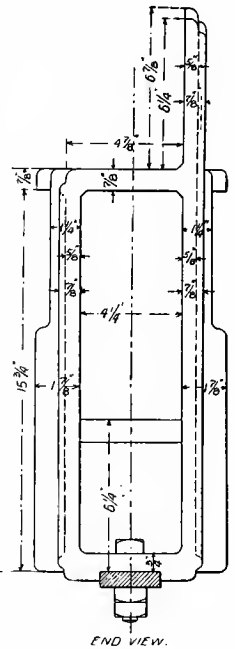

Fig. 5482. End Elevation.

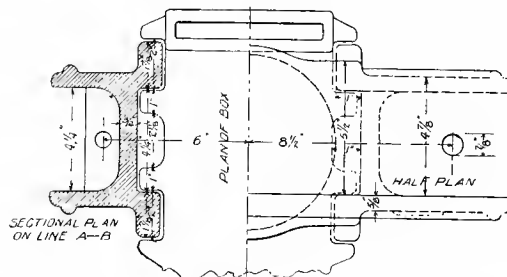

Fig. 5483. Sectional Plan with part of Oil-box.

MASTER CAR BUILDERS' STANDARD PEDESTAL.

Recommended in 1874, again approved in 1881, and adopted as standard in 1893. Weight, 141 lbs.



Fig. 5490.
TEST BAR FOR LIMIT-GAUGES.

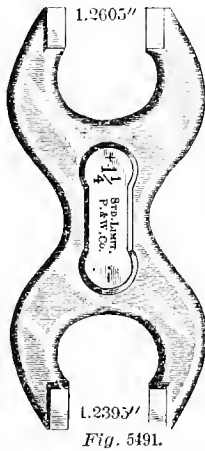

M. C. B. STANDARD
LIMIT GAUGE.
For 1 1/4 in. round iron.
See Dictionary for table
of other standard Limit
gauges.

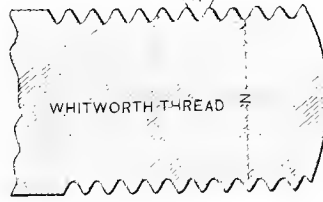
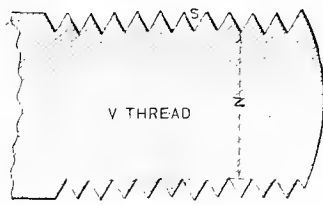

Figs. 5492-94.

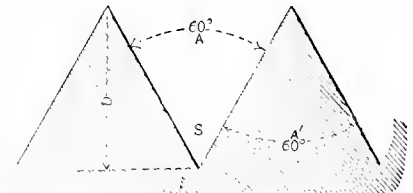

Fig. 5495. V SCREW-THREAD.

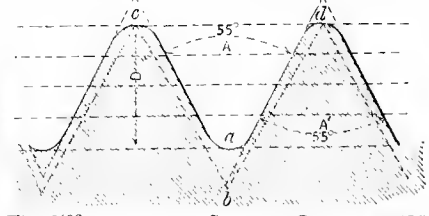

Fig. 5496. WHITWORTH STANDARD SCREW-THREADS.
English and Continental standard.

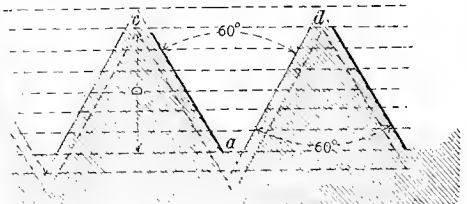

Fig. 4497. SELLERS' STANDARD SCREW-THREADS
U. S. and M. C. B. standard.

MASTER CAR BUILDERS' STANDARD DIMENSIONS FOR BOLTS AND NUTS (SELLERS STANDARD THREADS).

Diam. of Screw.	Threads per inch.	Diameter at root of Thread.	Area of Bolt at root of Thread.	Width of Flat.	Short Diam. Rough.	Short Diam. Finish.	Long Diam. Rough.	Long Diam. Finish.	Thickness Rough.	Thickness Finish.	Short Diam. Rough.	Short Diam. Finish.	Long Diam. Rough.	Long Diam. Finish.	Thickness Rough.	Thickness Finish.
1/8	20	.185	.12	.026	.0062	1/16	3/32	1/8	1/16	1/16	1/16	1/16	1/8	3/16	1/16	1/16
1/16	18	.240	.14	.045	.0074	1/16	1/8	1/4	1/16	1/16	1/16	1/16	1/8	1/4	1/16	1/16
3/16	16	.294	.16	.067	.0078	1/8	3/16	1/2	1/8	1/8	1/8	1/8	3/8	1/2	1/8	1/8
1/4	14	.344	.18	.092	.0089	3/16	1/4	3/4	1/8	1/8	1/8	1/8	1/2	3/4	1/8	1/8
5/16	13	.400	.20	.125	.0096	1/4	1/2	1 1/4	1/8	1/8	1/8	1/8	1 1/4	1 1/2	1/8	1/8
3/8	12	.454	.22	.161	.0104	3/8	1 1/4	1 3/4	1/8	1/8	1/8	1/8	1 3/4	2 1/4	1/8	1/8
1/2	11	.507	.24	.201	.0113	1/2	1 3/4	2 1/4	1/8	1/8	1/8	1/8	2 1/4	3 1/4	1/8	1/8
5/8	10	.620	.26	.301	.0125	5/8	2 1/4	3 1/4	3/8	3/8	3/8	3/8	3 1/4	4 1/4	3/8	3/8
3/4	9	.731	.28	.419	.0138	3/4	3 1/4	4 1/4	3/8	3/8	3/8	3/8	4 1/4	5 1/4	3/8	3/8
7/8	8	.837	.30	.550	.0156	7/8	4 1/4	5 1/4	1	1	1	1	5 1/4	6 1/4	1	1
1	7	.940	.32	.693	.0178	1	5 1/4	6 1/4	1 1/8	1 1/8	1 1/8	1 1/8	6 1/4	7 1/4	1 1/8	1 1/8
1 1/8	7	1.065	.34	.890	.0178	2	6 1/4	7 1/4	1 1/8	1 1/8	1 1/8	1 1/8	7 1/4	8 1/4	1 1/8	1 1/8
1 1/4	6	1.160	.36	1.056	.0208	2 1/8	7 1/4	8 1/4	1 1/8	1 1/8	1 1/8	1 1/8	8 1/4	9 1/4	1 1/8	1 1/8
1 1/2	6	1.284	.38	1.294	.0208	2 3/8	8 1/4	9 1/4	1 1/8	1 1/8	1 1/8	1 1/8	9 1/4	10 1/4	1 1/8	1 1/8
1 3/8	5 1/2	1.389	.40	1.515	.0227	2 7/8	9 1/4	10 1/4	1 1/8	1 1/8	1 1/8	1 1/8	10 1/4	11 1/4	1 1/8	1 1/8
1 3/4	5	1.491	.42	1.746	.0250	3	10 1/4	11 1/4	1 1/8	1 1/8	1 1/8	1 1/8	11 1/4	12 1/4	1 1/8	1 1/8
2	5	1.616	.44	2.051	.0250	3 1/8	11 1/4	12 1/4	1 1/8	1 1/8	1 1/8	1 1/8	12 1/4	13 1/4	1 1/8	1 1/8
2 1/8	4 1/2	1.712	.46	2.301	.0277	3 3/8	12 1/4	13 1/4	2	2	2	2	13 1/4	14 1/4	2	2
2 1/4	4 1/2	1.962	.48	3.023	.0277	3 7/8	13 1/4	14 1/4	2 1/8	2 1/8	2 1/8	2 1/8	14 1/4	15 1/4	2 1/8	2 1/8
2 1/2	4	2.176	.50	3.718	.0312	4 1/8	14 1/4	15 1/4	2 1/8	2 1/8	2 1/8	2 1/8	15 1/4	16 1/4	2 1/8	2 1/8
2 3/8	4	2.426	.52	4.622	.0312	4 3/8	15 1/4	16 1/4	2 1/8	2 1/8	2 1/8	2 1/8	16 1/4	17 1/4	2 1/8	2 1/8
3	3 1/2	2.629	.54	5.428	.0357	4 7/8	16 1/4	17 1/4	3	3	3	3	17 1/4	18 1/4	3	3
3 1/8	3 1/2	2.879	.56	6.509	.0357	5 1/8	17 1/4	18 1/4	3 1/8	3 1/8	3 1/8	3 1/8	18 1/4	19 1/4	3 1/8	3 1/8
3 1/4	3 1/2	3.100	.58	7.547	.0384	5 3/8	18 1/4	19 1/4	3 1/8	3 1/8	3 1/8	3 1/8	19 1/4	20 1/4	3 1/8	3 1/8
3 3/8	3	3.317	.60	8.641	.0413	5 7/8	19 1/4	20 1/4	3 3/8	3 3/8	3 3/8	3 3/8	20 1/4	21 1/4	3 3/8	3 3/8
4	3	3.567	.62	9.993	.0413	6 1/8	20 1/4	21 1/4	4	4	4	4	21 1/4	22 1/4	4	4
4 1/8	2 1/2	3.798	.64	11.329	.0435	6 3/8	21 1/4	22 1/4	4 1/8	4 1/8	4 1/8	4 1/8	22 1/4	23 1/4	4 1/8	4 1/8
4 1/4	2 1/2	4.028	.66	12.742	.0451	6 7/8	22 1/4	23 1/4	4 1/8	4 1/8	4 1/8	4 1/8	23 1/4	24 1/4	4 1/8	4 1/8
4 3/8	2 1/2	4.256	.68	14.226	.0476	7 1/8	23 1/4	24 1/4	4 3/8	4 3/8	4 3/8	4 3/8	24 1/4	25 1/4	4 3/8	4 3/8
5	2 1/2	4.480	.70	15.763	.0500	7 3/8	24 1/4	25 1/4	5	5	5	5	25 1/4	26 1/4	5	5
5 1/8	2 1/2	4.730	.72	17.570	.0500	7 7/8	25 1/4	26 1/4	5 1/8	5 1/8	5 1/8	5 1/8	26 1/4	27 1/4	5 1/8	5 1/8
5 1/4	2 1/2	4.953	.74	19.287	.0526	8 1/8	26 1/4	27 1/4	5 1/8	5 1/8	5 1/8	5 1/8	27 1/4	28 1/4	5 1/8	5 1/8
5 3/8	2 1/2	5.203	.76	21.261	.0526	8 3/8	27 1/4	28 1/4	5 3/8	5 3/8	5 3/8	5 3/8	28 1/4	29 1/4	5 3/8	5 3/8
6	2 1/2	5.423	.78	23.097	.0555	8 7/8	28 1/4	29 1/4	6	6	6	6	29 1/4	30 1/4	6	6

(Square nuts are of the same widths, between parallel faces, as hexagon. The following are the general rules for the dimensions of nuts and bolt-heads on which the above table is based:

- Diameter Rough Nut = one and one-half diameter of bolt + 1/8.
- Finished Nut = one and one-half diameter of bolt + 1-16.
- Rough Head = one and one-half diameter of bolt + 1/8.
- Finished Head = one and one-half diameter of bolt + 1-16.
- Thickness Rough Nut = diameter of bolt.
- Finished Nut = diameter of bolt - 1-16.
- Rough Head = one-half distance between parallel sides of head.
- Finished Head = diameter of bolt - 1-16.

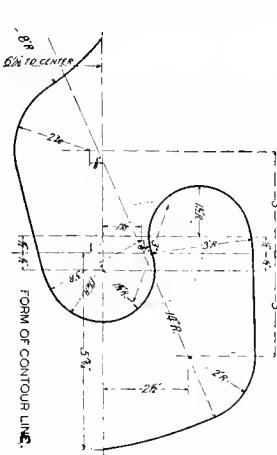

Fig. 5499.
CONTOUR LINE OF
AUTOMATIC COUPLER.

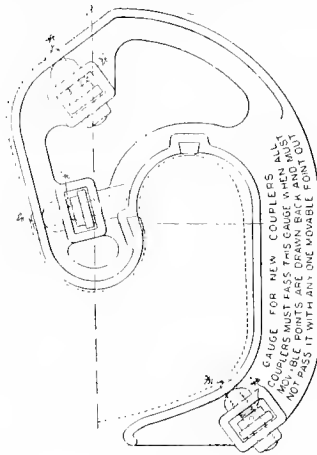
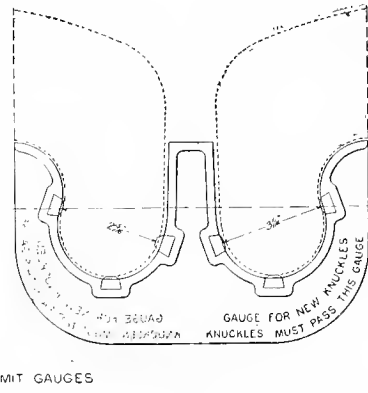

Fig. 5500.
LIMIT GAGES FOR M. C. B. AUTOMATIC COUPLER
Adopted in 1891.



LIMIT GAGES

Fig. 5501.

STANDARD LINES FOR THE KNUCKLE OF COUPLERS.

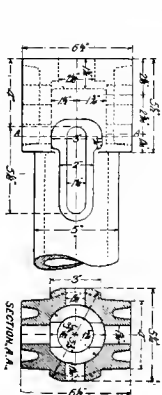

Figs. 5504-5505.
TAIL-END FOR CON-
TINUOUS DRAFT.

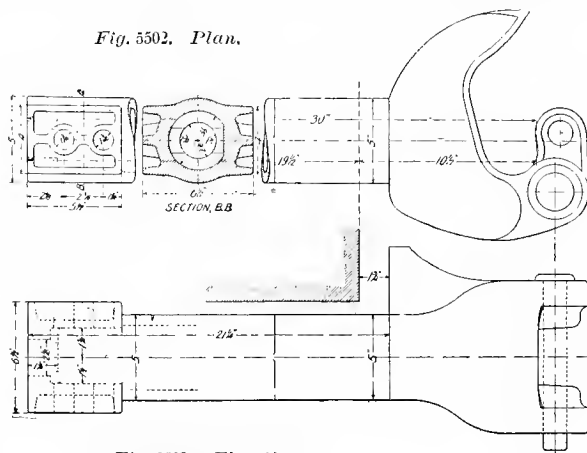

Fig. 5503. Elevation.
MASTER CAR BUILDERS' STANDARD AUTOMATIC CAR-COUPLER.
(Adopted in 1887. Further details adopted in 1889 and 1893.)

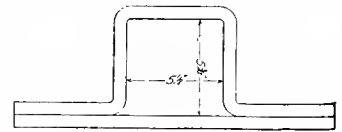

Fig. 5507. FRONT CARRY-IRON.

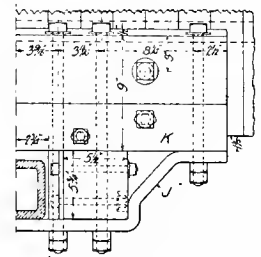

Fig. 5506.
Half End Elevation.

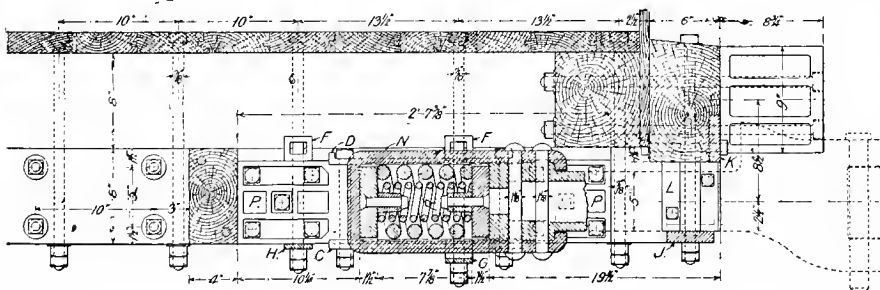

Fig. 5508. Sectional Elevation.

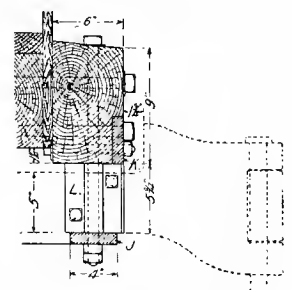
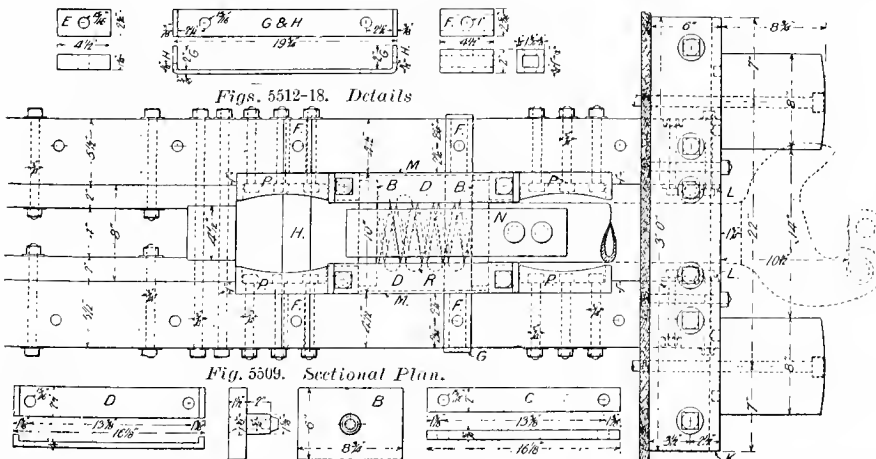

Fig. 5510. Section of End-sill.



Figs. 5512-18. Details

Fig. 5509. Sectional Plan.

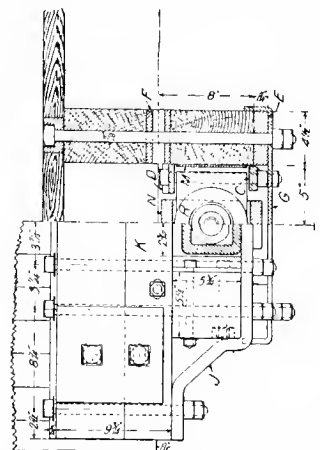

Fig. 5511. Cross Section and End Elevation.

Figs. 5519-5524. Details.

ATTACHMENT OF COUPLER, RECOMMENDED BY MASTER CAR BUILDERS' ASSOCIATION IN 1893.

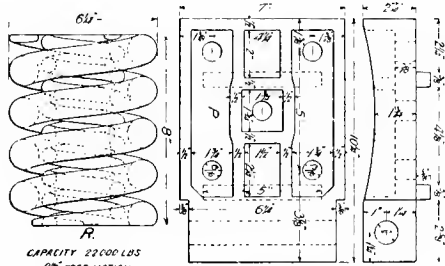
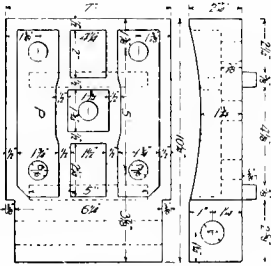
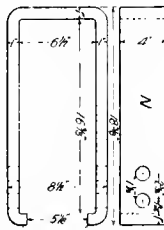

Fig. 5525.
DRAFT-SPRING.



Figs. 5526-5527.
STOP-PLATE.



Figs. 5528-5529.
YOKE OR STRAP-POCKET.
RECOMMENDED PRACTICE IN ATTACHMENT OF COUPLERS.

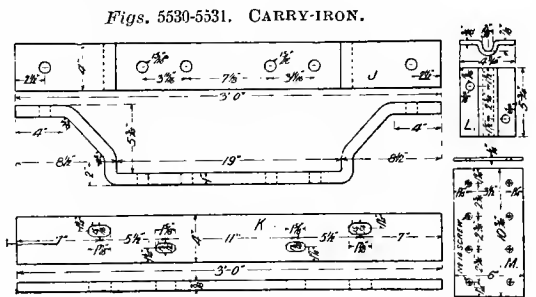

Figs. 5530-5533.
FOLLOWER-PLATE STRAP.

Figs. 5534-5537.

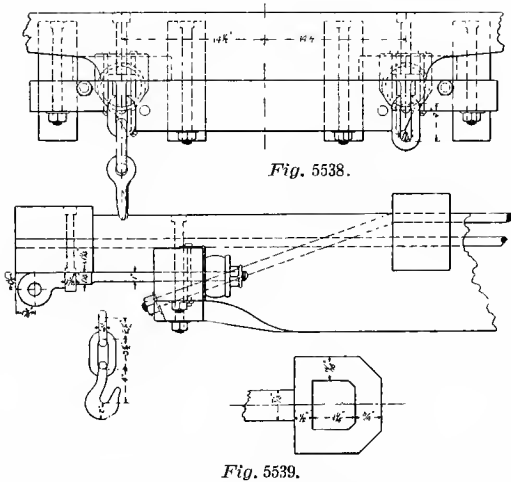
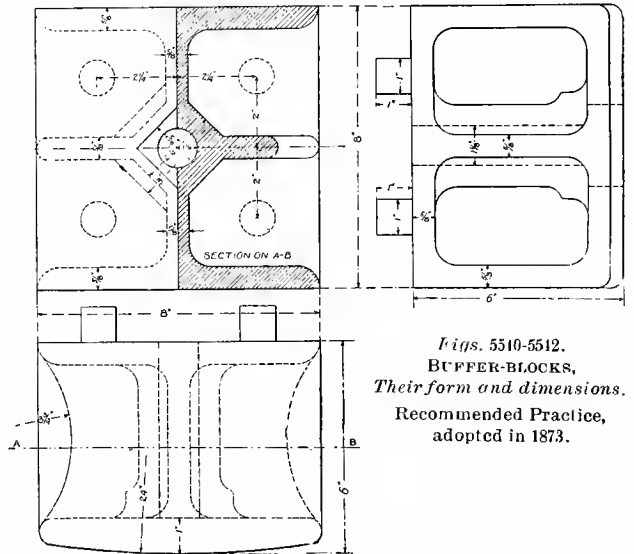
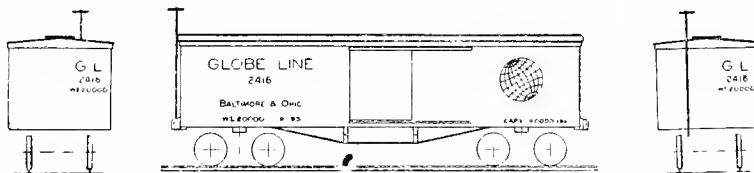

Fig. 5538.
PLATFORM SAFETY-CHAINS FOR PASSENGER EQUIPMENT.
Recommended Practice, adopted in 1893.



Figs. 5510-5512.
BUFFER-BLOCKS,
Their form and dimensions.
Recommended Practice,
adopted in 1873.



Figs. 5543-5545.
MARKINGS FOR FAST FREIGHT LINE CARS.
Recommended Practice, adopted in 1893.

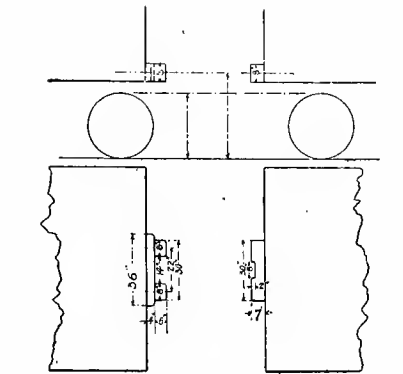

Figs. 5548-5549.
THE LOCATION OF BUFFER-BLOCKS AND
BUFFER-BEAM.

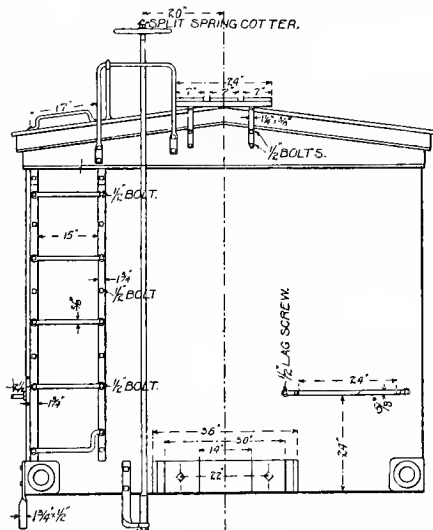

Fig. 5546. End Elevation.
POSITIONS AND DIMENSIONS OF BRAKE SHAFT, RUNNING BOARDS,
LADDER AND HANDHOLDS.

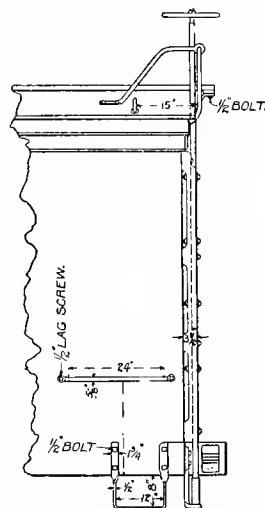

Fig. 5547. Side Elevation of Car End.
RECOMMENDED PRACTICE FOR THE PROTECTION OF TRAINMEN.

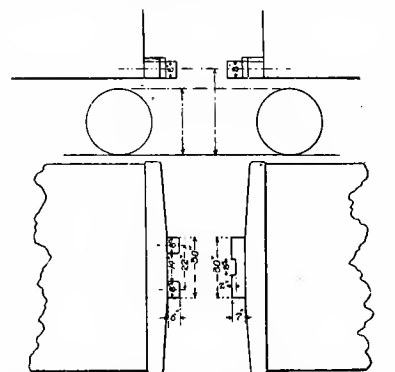

Fig. 5550-5551. THE LOCATION OF BUFFER
BLOCKS AND BUFFER-BEAM.

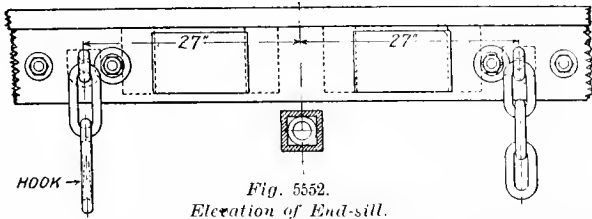

Fig. 5552. Elevation of End-sill.

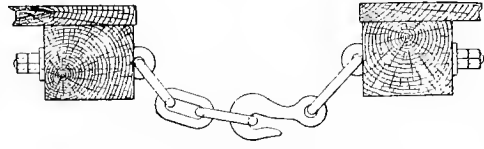

Fig. 5551. Cross Section of End-sills.

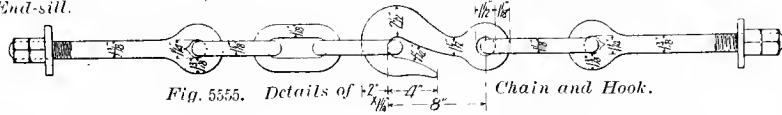

Fig. 5555. Details of Chain and Hook.

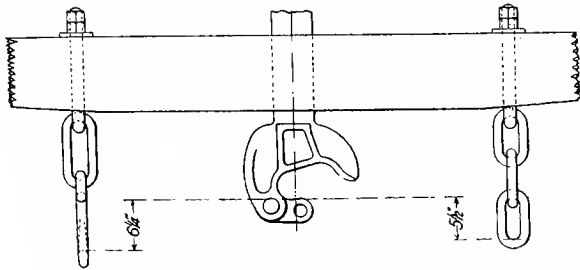
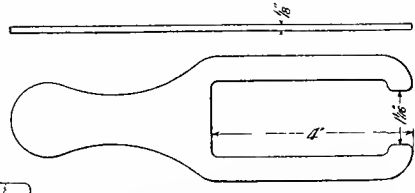
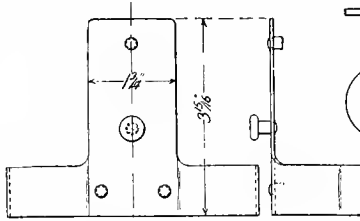
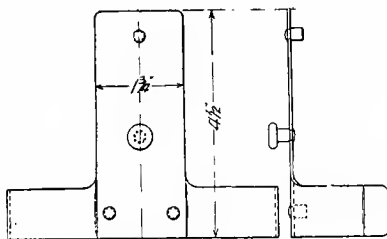

Fig. 5553. Plan of End-sill and Chains.

SAFETY-CHAINS FOR FREIGHT-CARS.

Recommended in 1894 by Master Car Builders' Association.



BEARING-THICKNESS GAUGE 3 3/4 x 7 & 4 1/2 x 8 JOURNALS

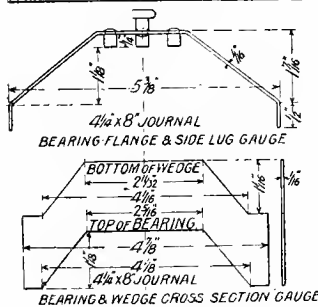

BEARING & WEDGE CROSS SECTION GAUGE

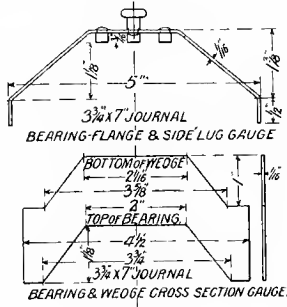

BEARING & WEDGE CROSS SECTION GAUGE.

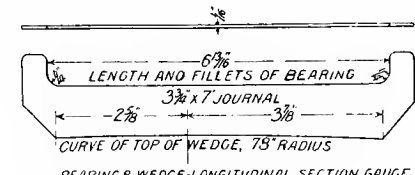

BEARING & WEDGE LONGITUDINAL SECTION GAUGE

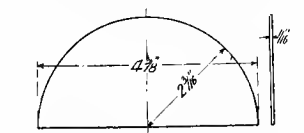

BEARING BORE-GAUGE 4 1/2 x 8 JOURNAL

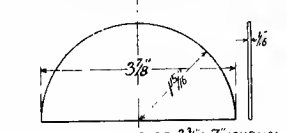

BEARING-BORE GAUGE 3 3/4 x 7 JOURNAL.

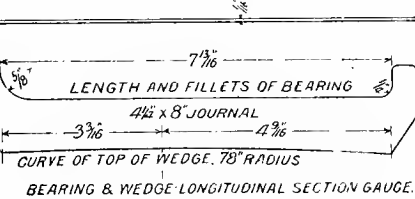

BEARING & WEDGE LONGITUDINAL SECTION GAUGE.

Figs. 5556-5571. JOURNAL-BEARING AND WEDGE GAGES.

Recommended in 1894 by Master Car Builders' Association.

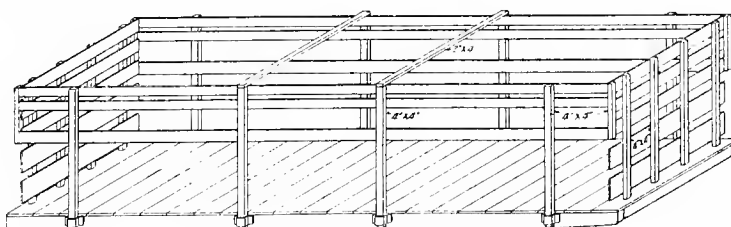
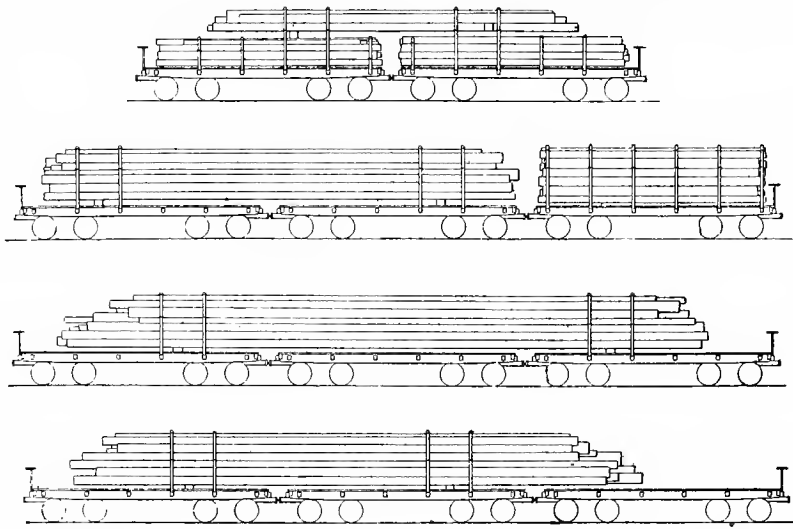

Fig. 5572. RECOMMENDED PRACTICE IN RACKING A CAR FOR LOADING BARK.



Figs. 5573-5576. RECOMMENDED PRACTICE FOR LOADING POLES AND LOGS.
The lines across Stakes indicate Ties across Cars.

REVERSE.

THE R'Y
AIR BRAKE CARD.
AIR BRAKE CUT OUT.

Applied to Car No. Initials.
Date at Inspector.
By Train No.
By Conductor.

THE R'Y

AIR BRAKE CUT OUT

CAR CAN BE PLACED BETWEEN
AIR BRAKE CARS.

Car No. Initials. Date.
Card applied at for following
Defects

By By
Inspector. Conductor.

Train No.

Repaired at
Date
By
Nature of Repairs

Fig. 5577. Reverse Side.

OVERSE.

THE R'Y
DEFECTIVE AIR BRAKE
CARD.

Applied to Car No. Initials.
Date at Inspector.
By Train No.
By Conductor.

THE R'Y

Defective Air Brake.

CAR CANNOT BE PLACED BETWEEN
AIR BRAKE CARS.

Car No. Initials. Date.
Card applied at for following
Defects

By By
Inspector. Conductor.

Train No.

Repaired at
Date
By
Nature of Repairs

Fig. 5578. Obverse Side.

AIR-BRAKE CUT-OUT AND DEFECT-CARD.

Other Standards and Recommended Practice and particulars with regard to those illustrated are described in the text under the name or title of each.

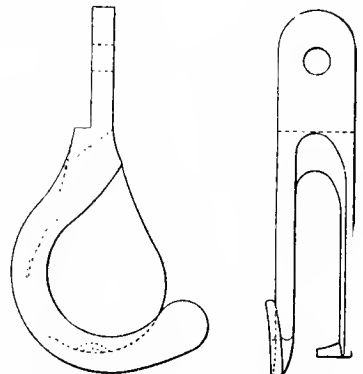

Figs. 5579-80. DUMMY COUPLING-HOOK.

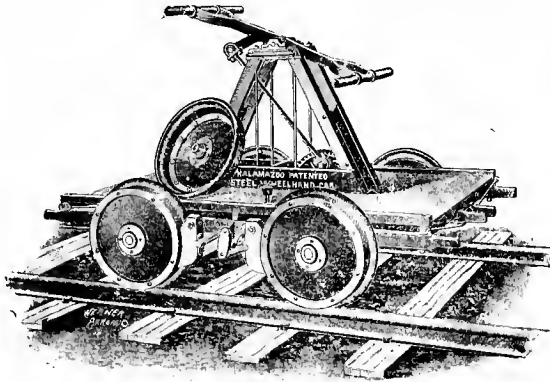

Fig. 5581. Perspective View, showing Steel Wheels.

THE KALAMAZOO STANDARD SECTION HAND-CAR.

Platform, 6½ ft. × 4½ ft. Wheels, 20 ins. in diameter. Weight, 550 lbs.

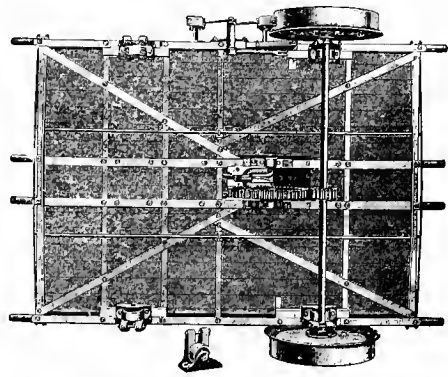

Fig. 5582. View of Underside, showing Roller Bearings.

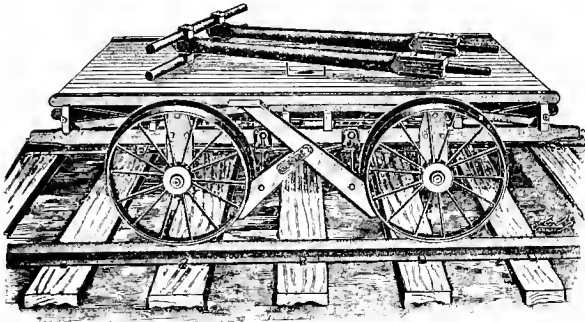

Fig. 5583. Perspective View.

Propelling levers detached. Platform, 6 ft. × 4½ ft. Weight, 500 lbs.

THE "CYRUS ROBERTS" TRUSS-FRAME COMBINATION CARS.

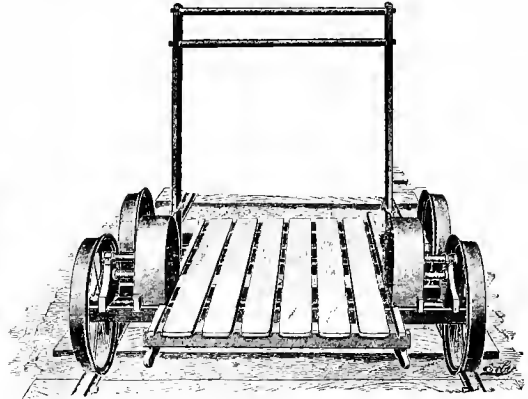

Fig. 5534. Perspective View.

A light quick-service car.

Platform, 6 ft. × 3 ft. Weight, 165 lbs.

ROBERTS, THROP & COMPANY.

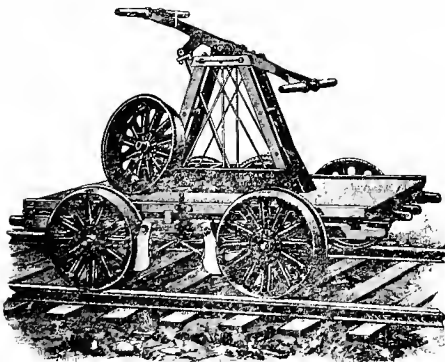

Fig. 5585. Perspective View.

SHEFFIELD No. 1 SECTION HAND-CAR.

Platform, 6 ft. × 4½ ft. Wheels, 20 ins. Weight, 510 lbs.

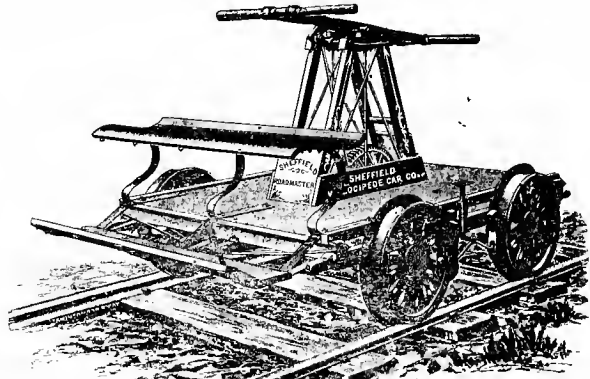

Fig. 5586. Perspective View.

ROADMASTER'S HAND-CAR.

20-in. wheels. Weight, 525 lbs.

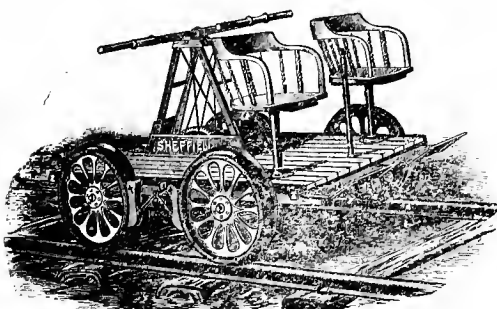

Fig. 5587. INSPECTION HAND-CAR.

Platform, 6 ft. × 4½ ft. Wheels, 22 ins. Weight, 400 lbs.

THE SHEFFIELD CAR COMPANY.

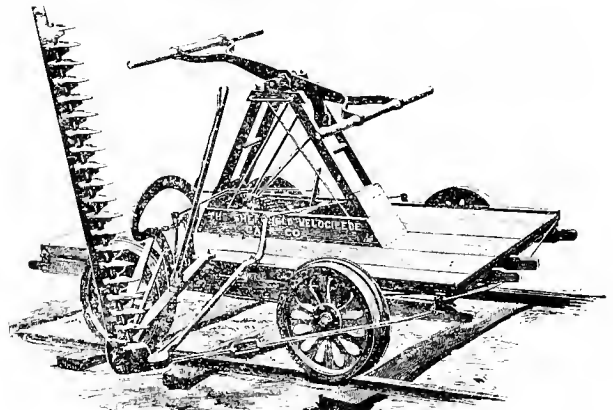

Fig. 5588. WEED-CUTTING CAR.

Cutting-bar folded for running.

Weight, 750 lbs.

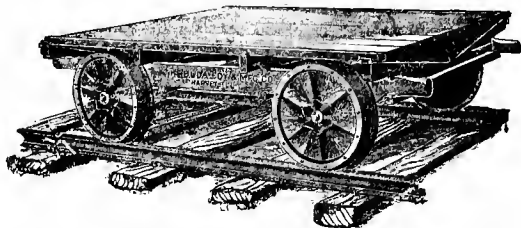

Fig. 5601. *Perspective View.*
THE BUDA PUSH-CAR No. 6.
Platform, 7 ft. \times 5½ ft. Weight, 450 lbs.

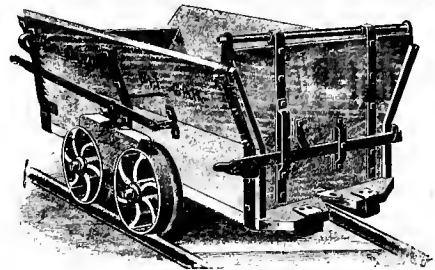

Fig. 5602. *Perspective View.*
KALAMAZOO MINE-CAR.



Fig. 5603. TRACK-LAYING CAR.
Size, 7 ft. 8 ins. \times 6 ft. 3 ins.
Capacity, 20,000 lbs. Weight, 1,300 lbs.



Fig. 5604. PUSH-CAR.
Platform, 7 ft. \times 5½ ft. Weight, 470 lbs

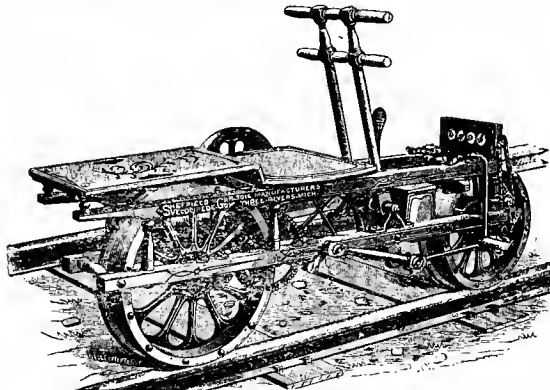

Fig. 5605. SHEFFIELD ODOMETER VELOCIPEDE-CAR.
For measuring track.

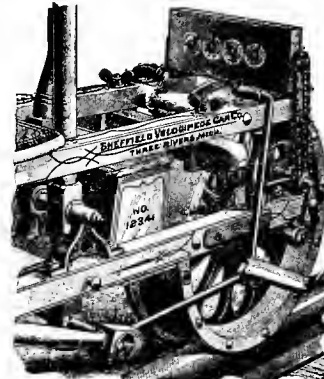

Fig. 5606. *Front End.*
ODOMETER VELOCIPEDE-CAR.

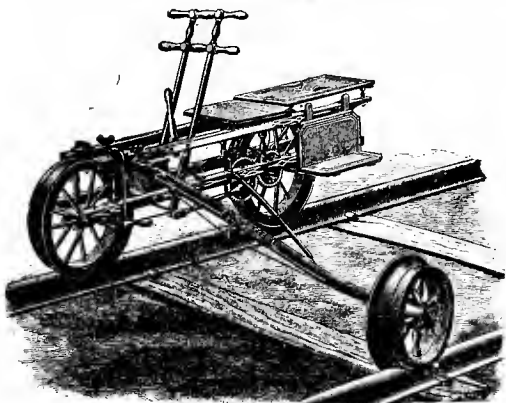

Fig. 5607. SHEFFIELD VELOCIPEDE-CAR No. 2.
For Rider and Passenger. Weight, 140 lbs.

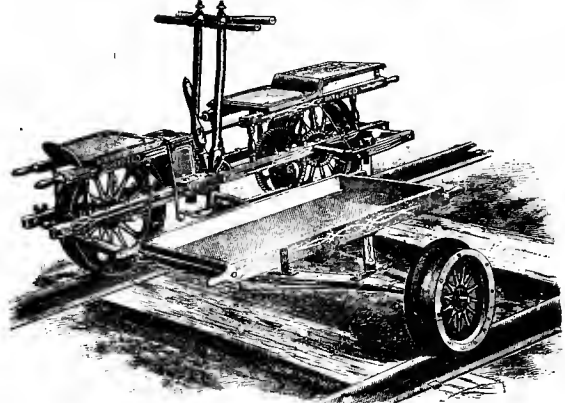

Fig. 5608. SHEFFIELD VELOCIPEDE-CAR No. 3.
For two Riders, and with Toolbox. Weight, 175 lbs.
VELOCIPEDE-CARS. SHEFFIELD CAR COMPANY.

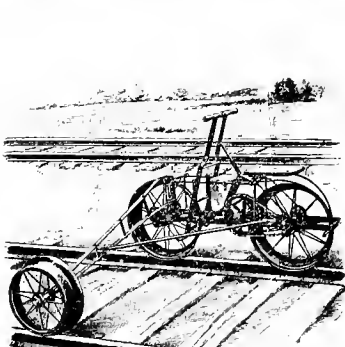

Fig. 5609. THE KALAMAZOO NEW
SPEEDER VELOCIPEDE-CAR.

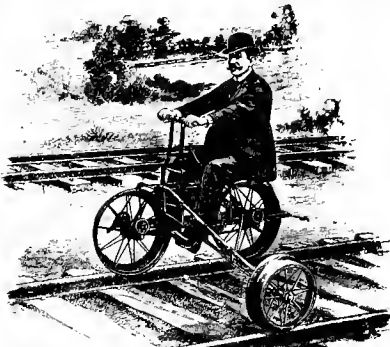

Fig. 5610. KALAMAZOO NEW SPEEDER
VELOCIPEDE-CAR.

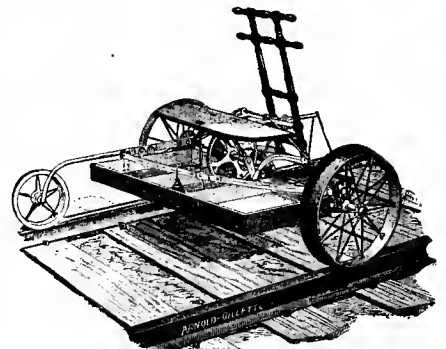

Fig. 5611. TELEGRAPH-LINE REPAIRERS'
VELOCIPEDE-CAR.
Capacity, two men and 200 lbs. Weight, 150 lbs.
VELOCIPEDE-CARS. KALAMAZOO RAILROAD VELOCIPEDE AND CAR COMPANY.

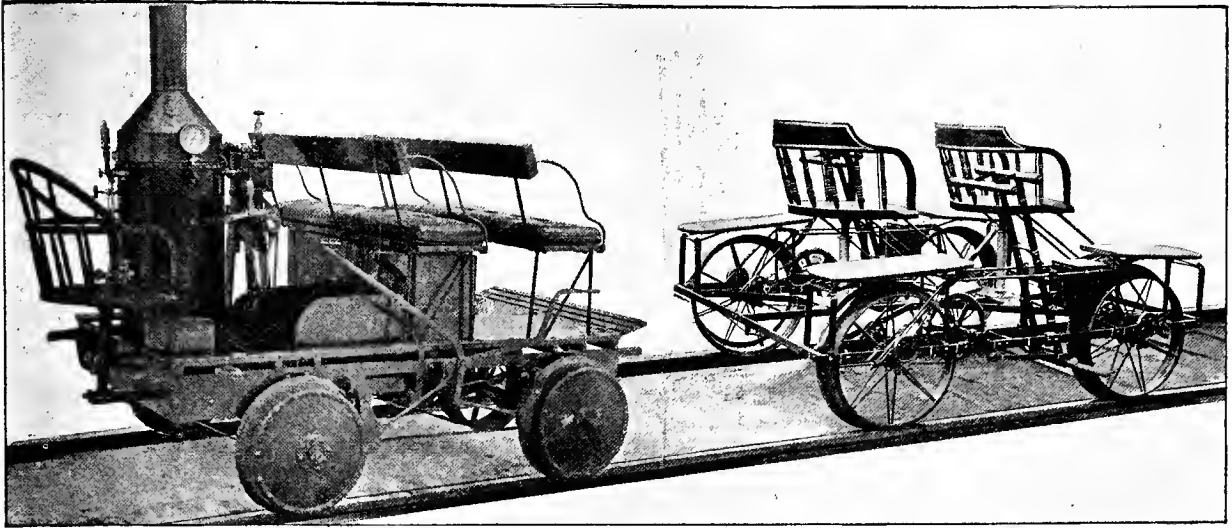

Fig. 5612 STEAM INSPECTION-CAR.
Capacity, 7 persons. Weight, 1,000 lbs. Speed, 20 to 25 miles an hour.

Fig. 5613. INSPECTION VELOCIPEDE-CAR.
For four riders and two passengers.

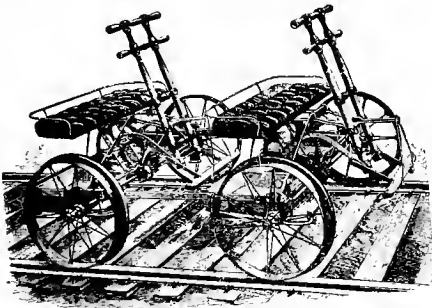

Fig. 5614
FOUR-SEATED TELFGRAPH GANG VELOCIPEDE.
Four-wheeled and with Roller-bearings.
Weight, 250 lbs.

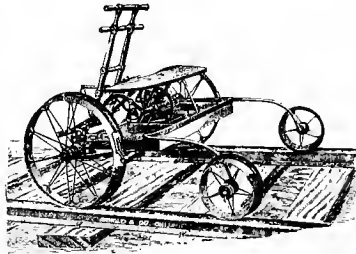

Fig. 5615.
FOUR-WHEELED STEEL VELOCIPEDE.
For Switch-lamp Lighters.
Weight, 150 lbs



Fig. 5616.
CRANK INSPECTION
HAND-CAR.
(Old style.)

KALAMAZOO RAILROAD VELOCIPEDE AND CAR COMPANY.

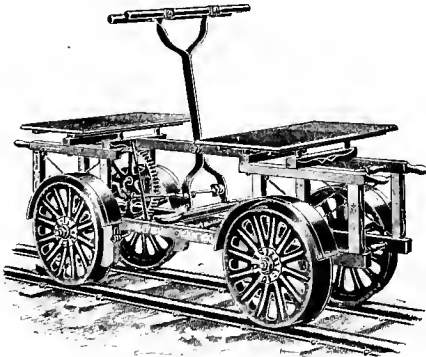

Fig. 5617. MINE VELOCIPEDE.

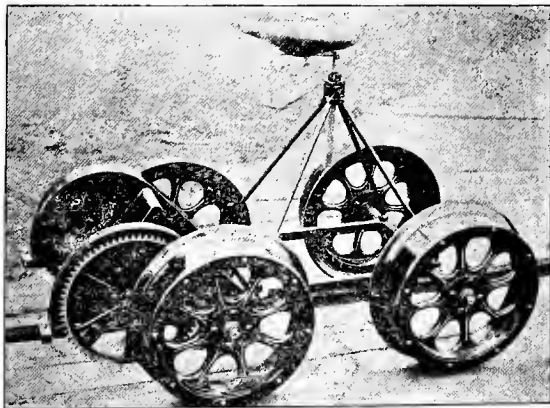
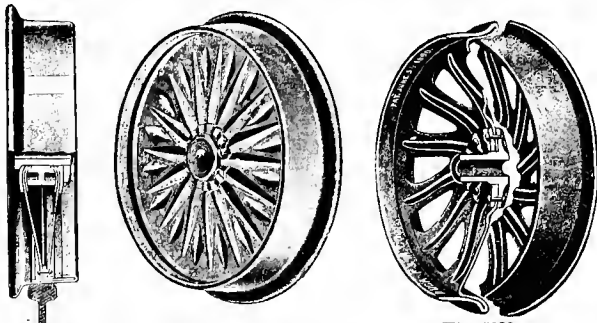

Fig. 5618. MINE AND TUNNEL VELOCIPEDE-CAR.
SHEFFIELD CAR COMPANY, THREE RIVERS, MICHIGAN.



Fig. 5619.
MINE AND TUNNEL VELOCIPEDE-CAR
WITH RIDER.



Figs. 5620-5621. THE BUDA CORRUGATED STEEL WHEEL. THE BUDA STEEL WHEEL.*
*The Tread and Web of Wheel are formed by Drawing and Spinning a Single Plate of Steel.

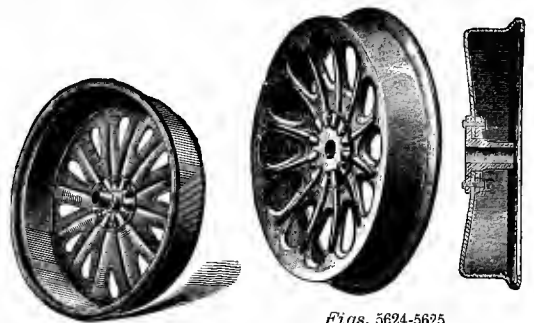
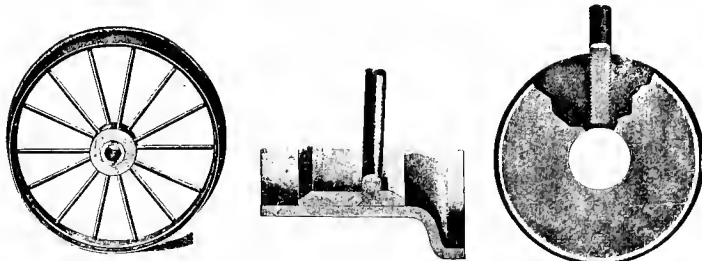
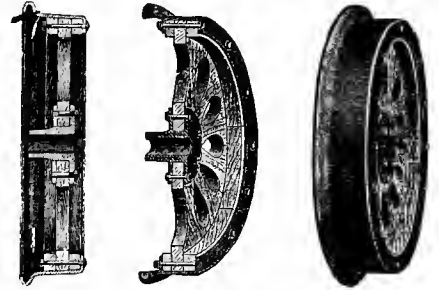

Fig. 5623. Inside View. Figs. 5624-5625. Outside View. Section.
THE SHEFFIELD ALL-STEEL WHEEL.
Drop Forged Hub; Wheel is made from one sheet of Steel.



Figs. 5626-5628 THE CYRUS ROBERTS STEEL-TIRED WHEEL.
Cast Hub, Steel Spokes and Felloe and Steel Flanged Tires.
New tires may be shrunk on to center.



Figs. 5629-5631. THE SHEFFIELD HAND-CAR WHEEL.
Hub and Rim of Steel, Wood Felloe and Spokes.

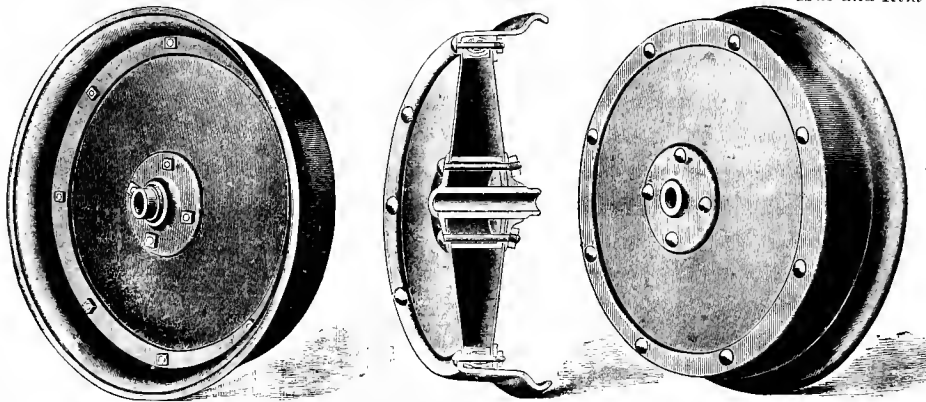

Figs. 5632-5634. KALAMAZOO ALL-STEEL HAND-CAR WHEEL.
Malleable-iron Flanged Hub, Double Steel-plate Center, Wood Felloe, Re-enforced with Steel Rings.



Fig. 5635.
SWING BARREL-TRUCK.



Fig. 5636.
TELESCOPE TRUCK.

Fig. 5637.
BAGGAGE AND EXPRESS
WAGON-TRUCK.

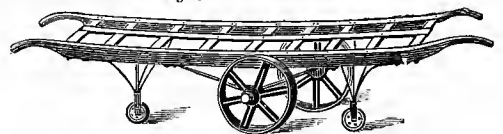

Fig. 5638.
BAGGAGE BARROW.



Fig. 5639. BAGGAGE BARROW.

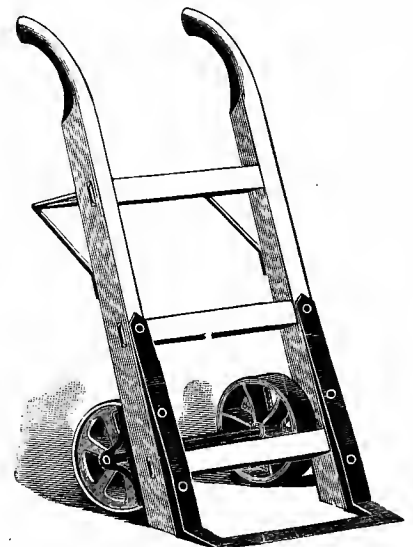

Fig. 5641. STEEL NOSED RAILROAD TRUCK

Fig 5640. THE REYNOLDS DEPOT TRUCK FOR BAGGAGE AND EXPRESS.

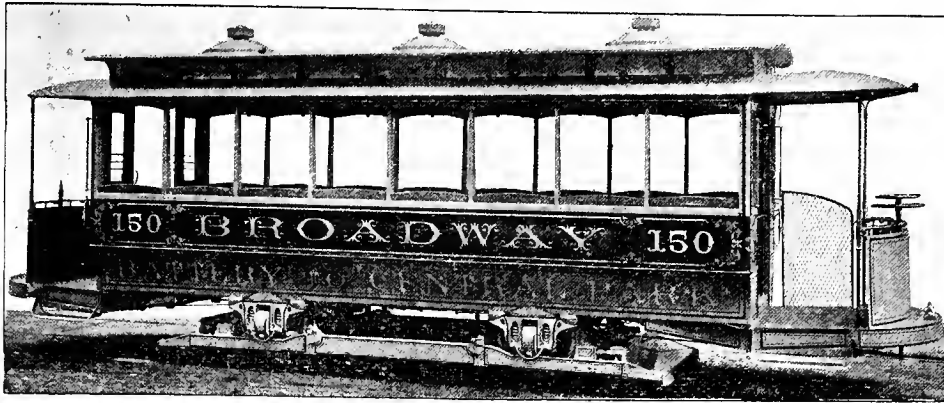

Fig 5642. CLOSED CABLE-CAR. METROPOLITAN TRACTION COMPANY, NEW YORK CITY.
THE JOHN STEPHENSON COMPANY, NEW YORK.

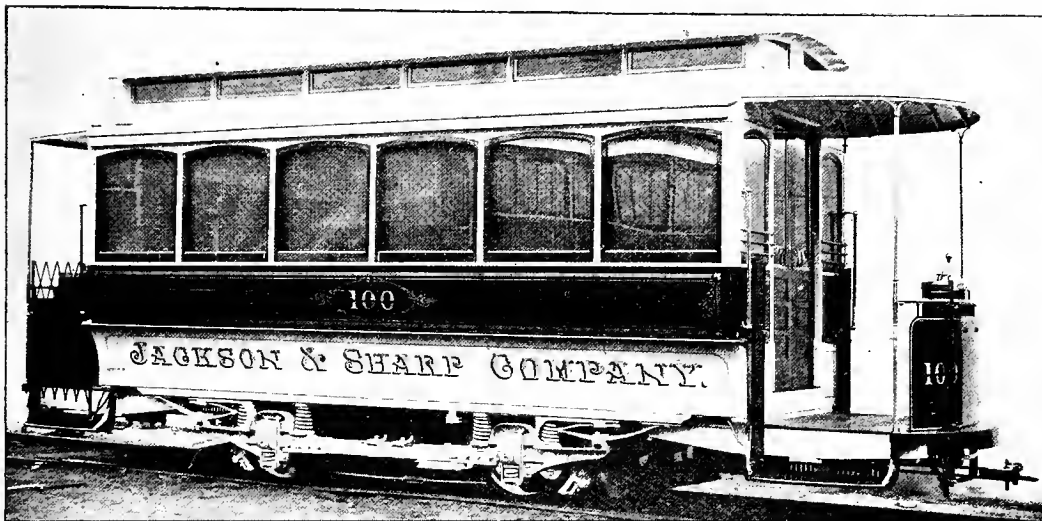

Fig. 5643. CLOSED ELECTRIC-MOTOR CAR. JACKSON & SHARP COMPANY, WILMINGTON, DELAWARE.
Length of Car-body, 18 ft. 6 ins. Length Over-all, 26 ft. 6 ins.
No. 11A MCGUIRE COLUMBIAN TRUCKS.



Fig. 5644. SPECIAL CLOSED ELECTRIC-MOTOR PARLOR-CAR FOR "TROLLEY PARTIES."
WEST END STREET RAILWAY COMPANY, BOSTON.
Length, 20 ft. Width, 7 ft. 4 ins. Seating capacity, 20 persons. Car-body built by J. M. Jones' Sons, West Troy, N. Y.
West End Trucks built by the Laconia Car Company, Laconia, N. H.



Fig. 5645. CLOSED CABLE-CAR. THIRD AVENUE RAILROAD COMPANY, NEW YORK CITY.
BUILT BY THE LACLEDE CAR COMPANY, ST. LOUIS.



Fig. 5646. CLOSED ELECTRIC-MOTOR CAR. WEST END STREET RAILWAY, BOSTON.
BUILT BY J. M. JONES' SONS, WEST TROY, N. Y.
Equipped with Bemis Four-wheeled Trucks.

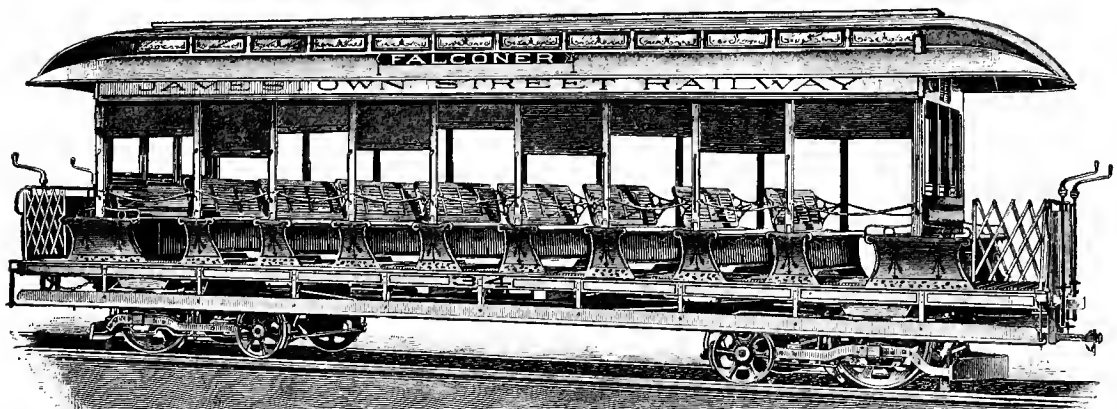

Fig. 5644. TWELVE-SEAT OPEN ELECTRIC-CAR. J. G. BRILL COMPANY, PHILADELPHIA.
Length over-all, 34 ft. Width of Underframe, 6 ft. 4 ins. Seating capacity, 60 persons. Total weight, 11,200 lbs.
Brill's Eureka Maximum-traction Pivotal Trucks.

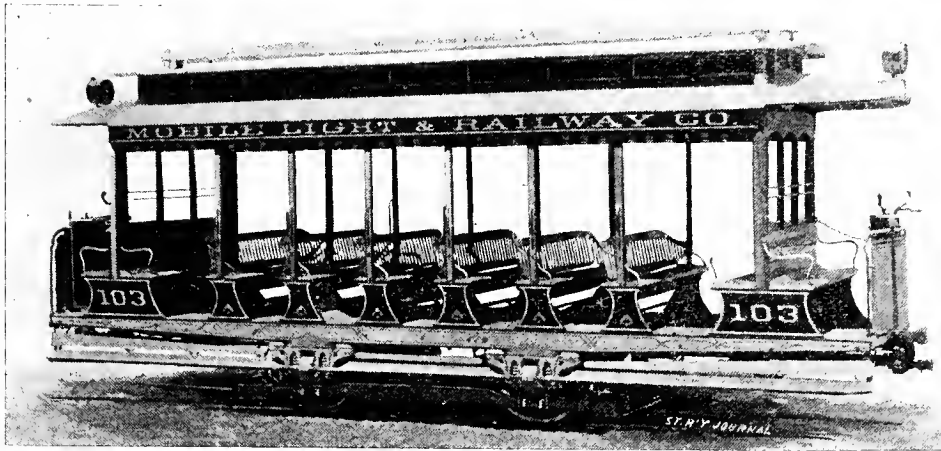

Fig. 5618. OPEN ELECTRIC-MOTOR CAR. THE JOHN STEPHENSON COMPANY.
 Seating capacity, 50 persons. Ends closed with sashes. Monitor Roof.
 Tackaberry Truck with Stephenson Super-spring Running Gear.

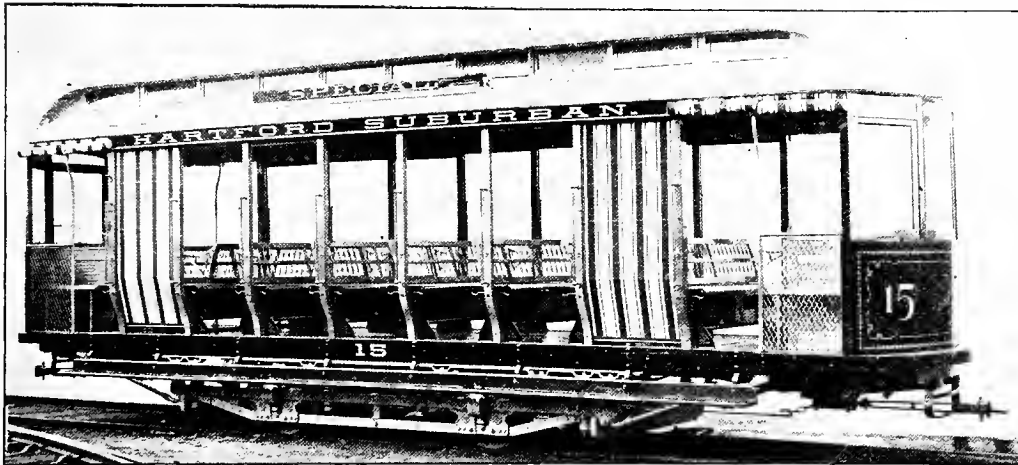

Fig. 5649. OPEN ELECTRIC-MOTOR CAR, WITH INCLOSED ENDS AND STEAM CAR ROOF.
 Length over all, 30 ft. No. 6E Peckham Trucks.
 JACKSON & SHARP COMPANY, WILMINGTON, DELAWARE.

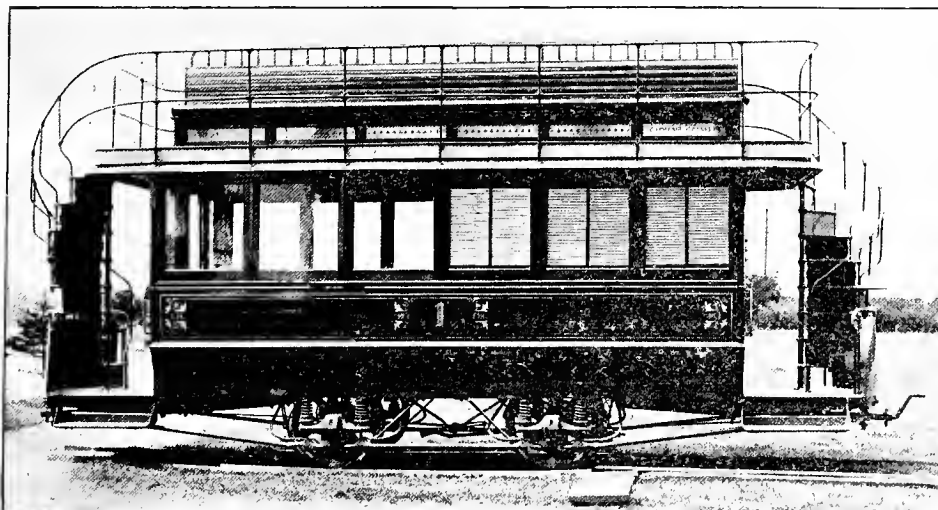

Fig. 5550. STREET-CAR DOUBLE-DECKED TRAILER-CAR, FOR CABLE OR ELECTRIC ROADS.
 PULLMAN'S PALACE CAR COMPANY.

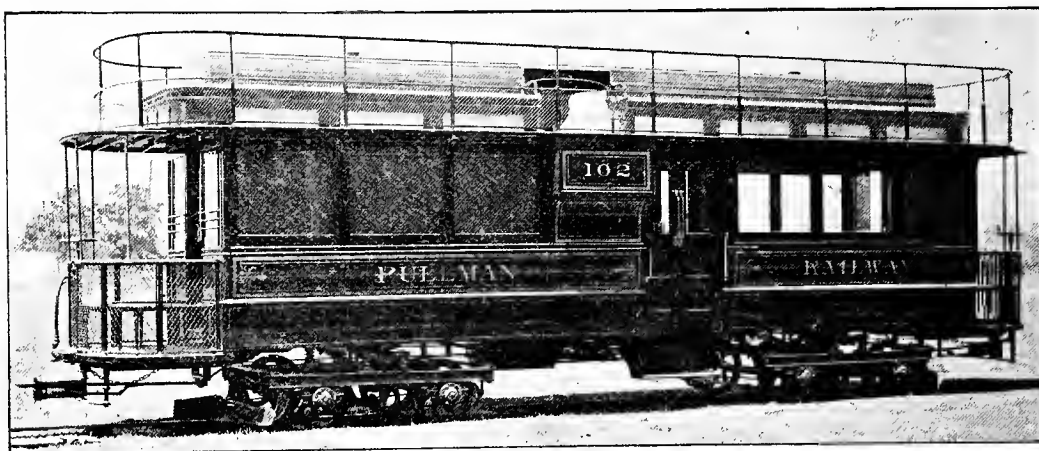

Fig. 5651. DOUBLE-DECKED STREET-CAR FOR ELECTRIC ROADS. PULLMAN RAILWAY.
PULLMAN'S PALACE CAR COMPANY.

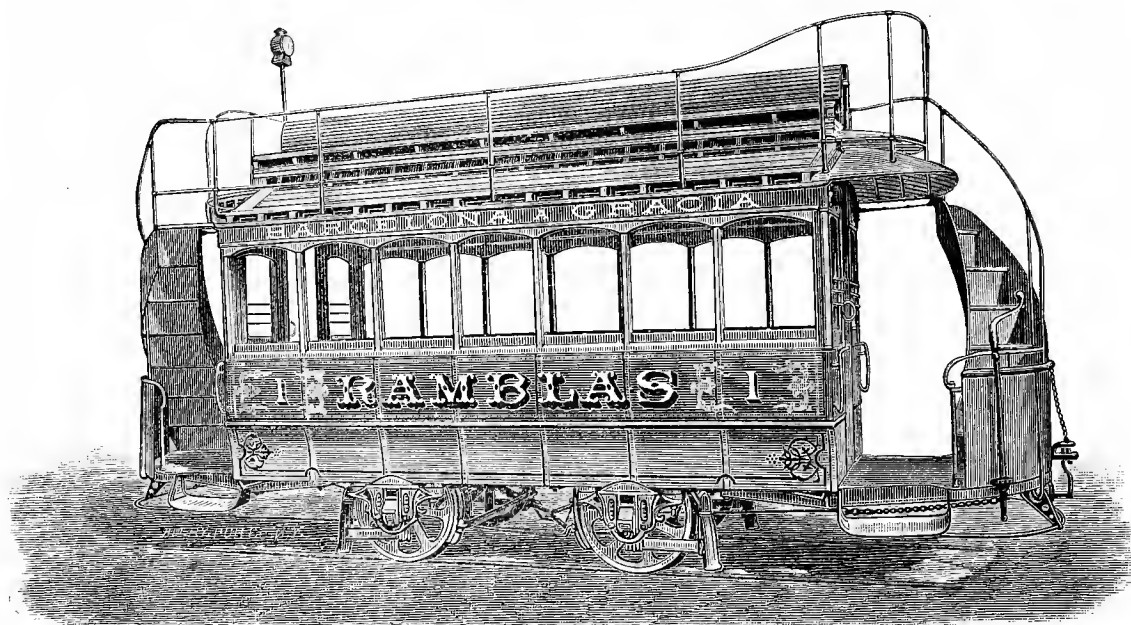

Fig. 5652. DOUBLE-DECKED STREET-CAR. JOHN STEPHENSON COMPANY.
Built for Foreign Trade.

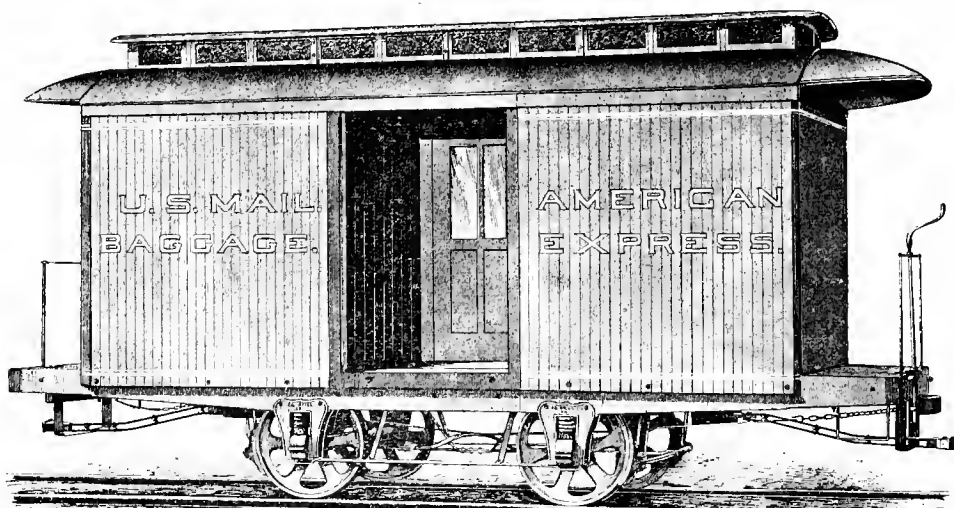

Fig. 5653. MAIL, BAGGAGE AND EXPRESS CAR FOR ELECTRIC ROADS. J. G. BRILL COMPANY.
Length of Car Body, 15 ft. 10 ins. Width, 7 ft. 4 ins. Weight, 5,500 lbs.

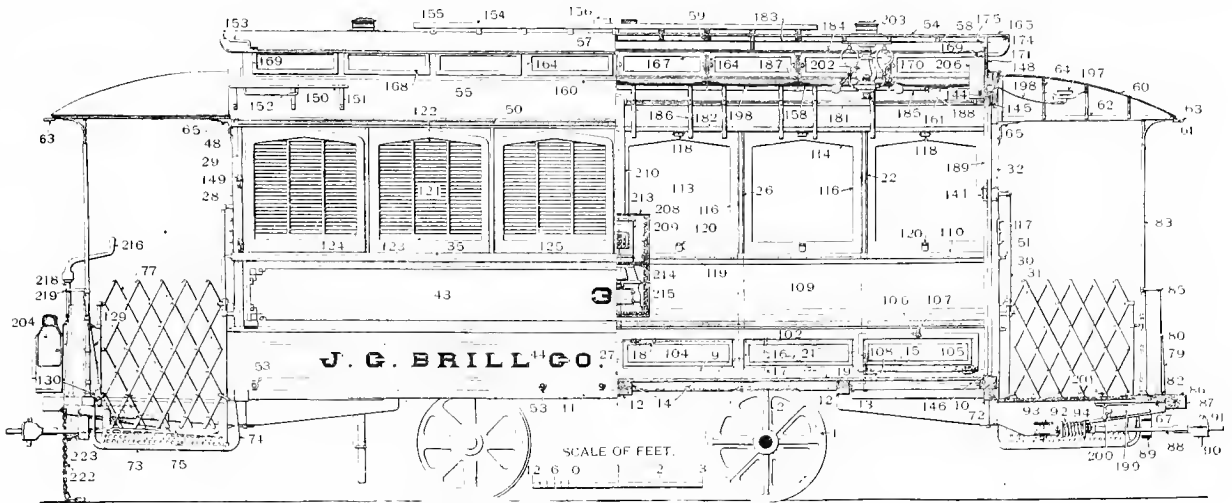

Fig. 5654. Half Side Elevation and Half Longitudinal Section.

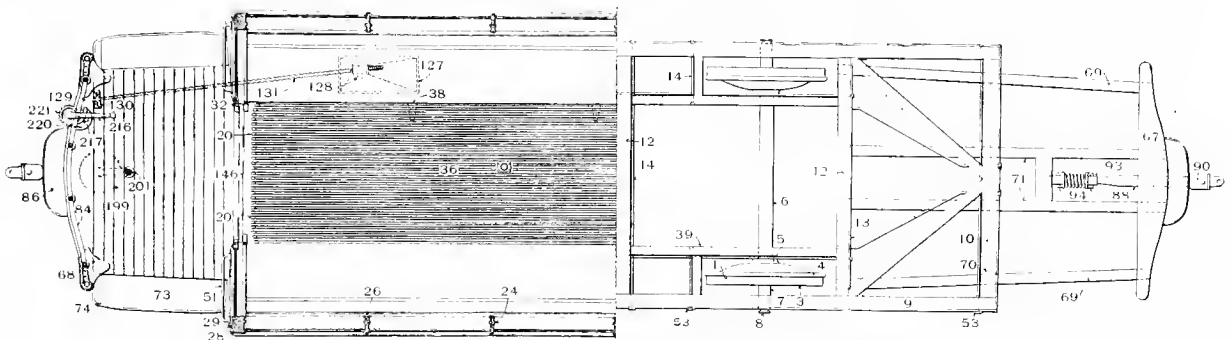

Fig. 5655. Half Plan of Car Floor and Half Plan of Underframe.

A CLOSED ELECTRIC-MOTOR CAR. J. G. BRILL COMPANY, PHILADELPHIA.

NAMES OF PARTS OF STREET-CARS.

Figs. 5654-5667.

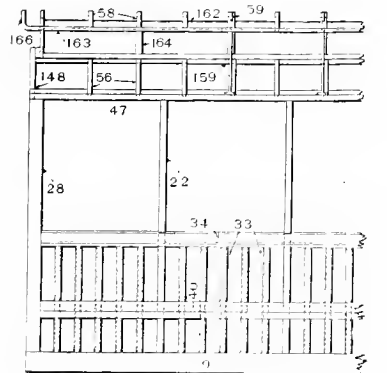

Fig. 5657. Part Elevation of Side Framing.

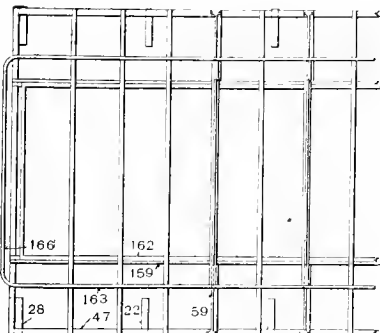

Fig. 5658. Part Plan of Roof Framing.

A CLOSED ELECTRIC-MOTOR CAR.

- A. Intermediate-sill.
- B. Floor-joist.
- C. Movable Floor-joist.
- D. Corner-brace.
- E. Brace-block.
- F. Knee-iron.
- 1. Wheel.
- 2. Spoke.
- 3. Tread.
- 4. Flange.
- 5. Hub.
- 6. Axle.
- 7. Journal.
- 8. Collar.
- 9. Side-sill.
- 10. End-sill.
- 11. Truck Sub-sill.
- 12. Transverse Floor-timber.
- 13. Transverse Floor-timber Plate.
- 14. Cross Tie-rods.
- 14a. Longitudinal Tie-rod.
- 15. Over-hang Truss-rod.
- 15a. Truss-rod Anchor.
- 15b. Truss-rod Anchor-bolts.
- 16. Truss-rod Queen-post.
- 17. Queen-post Base-plate.
- 18. Turnbuckle.
- 19. Floor.
- 20. Floor-strips.
- 21. Wheel-box.
- 22. Side-post.
- 23. Window-blind Rest.
- 24. Post Parting-strip.
- 25. Window-sash Rest.

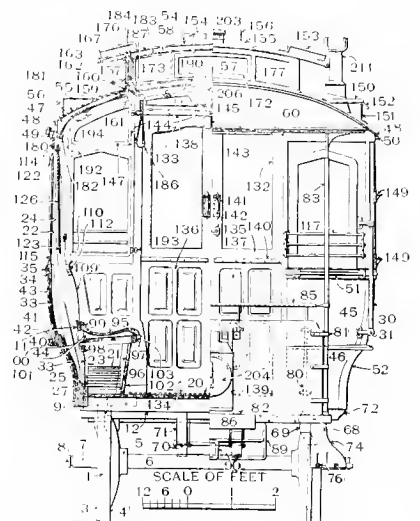

Fig. 5656. Half Cross Section
A CLOSED ELECTRIC-MOTOR CAR.

- 26. Post-molding.
- 27. Side-post Strap-belt.
- 28. Corner-post.
- 28a. End-post Knee-iron.
- 29. Corner-post Strap.
- 30. Corner-post Grab-handle.
- 31. Grab-handle Bracket.
- 32. Door-post.
- 33. Body-rib or Side-stud.
- 33a. Body-end Rib.
- 33b. Side-posts (same as 22).
- 34. Belt-rail.
- 35. Belt-rail Strap or Band.
- 36. Trap-door.

(Continued.)

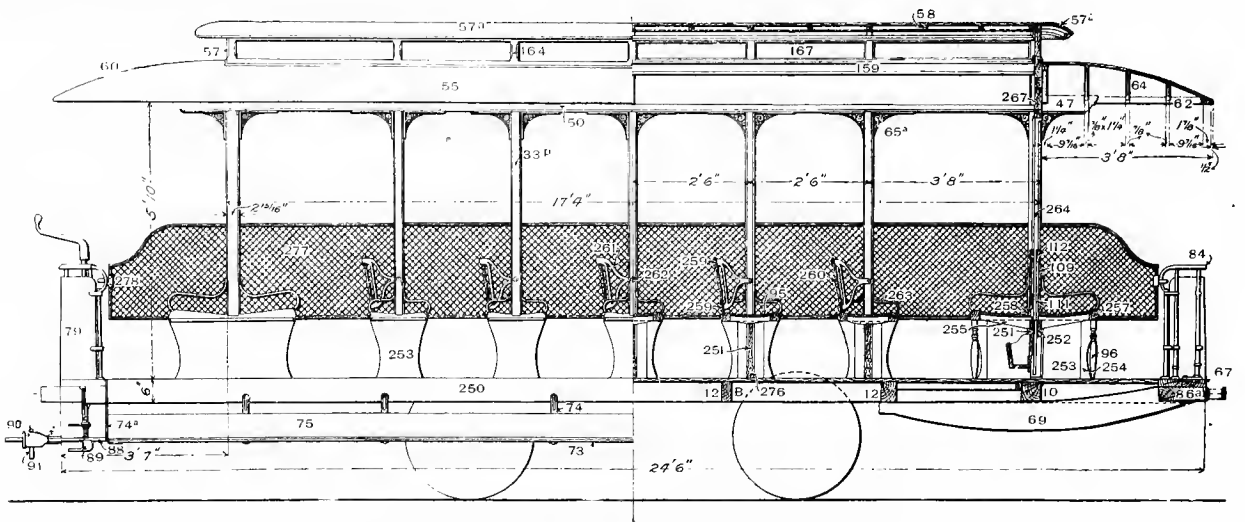

Fig. 5659. Half Side Elevation and Half Longitudinal Section.

NAMES OF PARTS OF STREET-CARS.

Figs. 5654-5667.

(Continued.)

- 37. Trap-door Ring.
- 38. Trap-door Hinge.
- 39. Trap-door Support.
- 40. Panel-furring.
- 40a. Body End-rail.
- 41. Guard or Fender-rail.
- 42. Guard-fender or Rail-strap.
- 43. Upper Outside or Convex-panel.
- 44. Lower Outside or Concave-panel.
- 45. Upper End-panel (removable).
- 46. Lower End-panel.
- 47. Top-rail or Body Side-plate.
- 48. Lower-deck Eaves-molding.
- 49. Letter-board.
- 50. Water-table or Window-lintel.
- 51. Body Hand-rail.
- 52. Concave-panel Corner-iron.
- 53. Panel-washer.
- 54. Roof-board.

(Continued.)

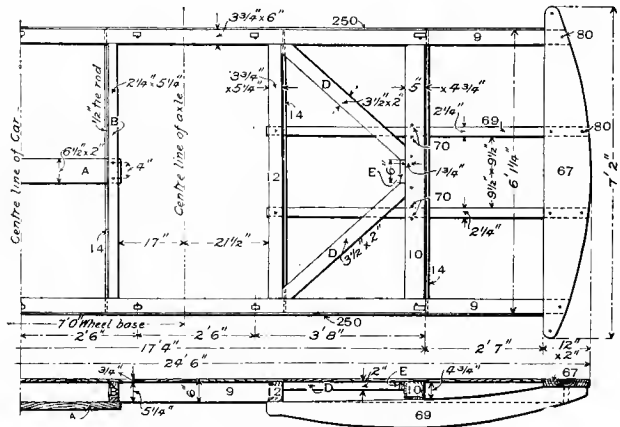

Fig. 5660. Half Plan.

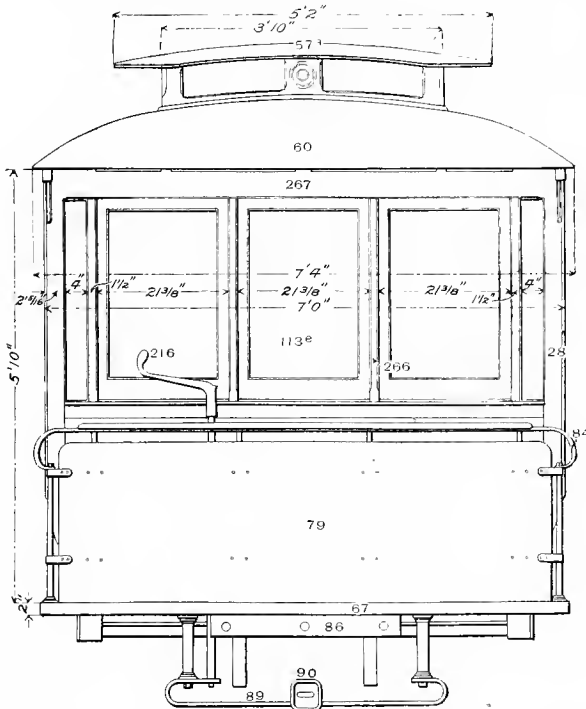

Fig. 5661. End Elevation.

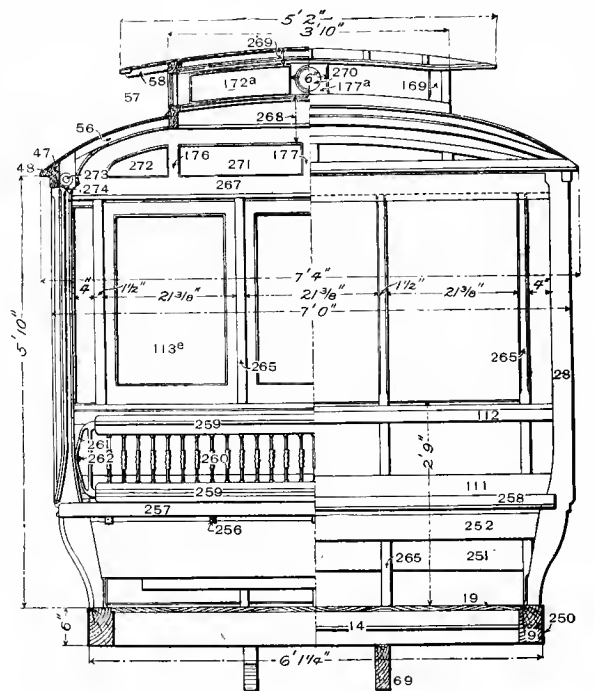

Fig. 5662. Half Cross Section and Sectional End Elevation of Framing.

55. Lower-deck Roof.
56. Lower-deck Carline or Rafter.
57. Clear-story or Upper Deck.
57a. Upper-deck Roof.
58. Upper-deck Carline.
58a. Upper-deck Furring-strip.
58b. Upper-deck Roof Guard-strip.
59. Compound-carline (Steel or Iron).
60. Platform-hood.
61. Platform-hood Molding.
62. Platform-hood Bow.
63. Platform-hood Band.
64. Platform-hood Carline.
64a. Platform-hood Shoulder Carline.
65. Platform-hood Bracket.
65a. Post-bracket.
66. Platform.
67. Crown-piece or Platform End-timber.
68. Crown-piece Corner-iron.
69. Platform-knee or Timber.
70. Platform Timber-clamp.
71. Platform Draft-knee.
72. Platform Sub-sill.
73. Step-tread.
74. Step-iron or Hanger.
75. Step-fender.
76. Platform Step-rod.
77. Platform Safety-gate (extension).
78. Safety-gate Holder.
79. Dasher or Dash-board.
80. Dasher-post.
81. Dasher-post Clip or Dasher-strap.
82. Dasher-post Washer.
83. Hood-support or Platform End-post.
84. Dasher-rail or Platform-rail.
85. Dasher-rail Cap.
86. Buffer.
86a. Buffer-beam.
87. Buffer-band.
88. Radiating Draft-bar.
89. Draft-bar Slide or Draw-bar Sector.
89b. Sector-bar Bolt.
90. Draft-head.
91. Draw-bar Pin.
92. Draft-spring.
93. Draft-spring Casting.
94. Key.
95. Seat-bottom.
95a. Seat-bottom Cover.
96. Seat-leg.
97. Front Seat-rail.
98. Back Seat-rail.
99. Seat-cove.
100. Seat-bearing Cross-bars.
101. Seat-bottom Cross-bars.
102. Seat-front.
103. Seat-front Rail.
103a. Seat-front Bottom-rail.
103b. Seat-cover Guard-rail.
104. Seat-front Panel.
105. Locker.
106. Locker-catch.
107. Locker-catch Plate.
108. Locker-hinge.
109. Seat-back.
109a. Seat-back Cross-bar.
109c. Seat-back Cover.
110. Finished Upper Seat-back Rail.
111. Seat-back Bottom-rail.
112. Seat-back Top-rail.
113. Window.
113e. End-window (stationary).
114. Upper Window-rail.
115. Lower Window-rail.
116. Window-stile.
117. Window-guard.
118. Window-sash Lift.
119. Window-sash Leather.
120. Window-sash Leather-plate.
121. Window-blind.
122. Upper Window-blind Rail.
123. Lower Window blind Rail.
124. Window-blind Stile.
125. Window-blind Mullion.
126. Window-blind Slat.
126a. Window-blind Lift.
126b. Window blind Spring.
127. Sand-box.
128. Sand-box Valve.
129. Sand-box Lever.
130. Sand-box Lever-holder.
131. Sand-box Connecting-rod.
132. Door-stile.
133. Top Door-rail.
134. Bottom Door-rail.
135. Door-lock Rail.
136. Door-muntin or Door-mullion.
137. Door-panel.
137g. Glass in Door.
138. Door-lintel.
138a. Door-casing.
139. Door-sill.
139a. Sliding-door.
140. Sliding-door Strip.
141. Sliding-door Handle.
142. Sliding-door Hook.
143. Sliding-door Sheave.
144. Sliding-door Roller.
145. Upper Door-track.
146. Lower Door-track.
147. Intermediate Door-track.
148. Head-piece or Body End-plate.
148a. Body End-furring.
149. Trolley-inspection Steps.
150. Trolley-inspection Roof-landing.
151. Roof-landing Irons.
152. Roof-landing Grab-handle.
153. Upper-deck Grab-handle.
154. Trolley-board.
155. Trolley-board Cleats.
156. Trolley Base-blocks.
157. Ventilator.
158. Ventilator-casing.
159. Upper-deck Bottom-rail.
160. Rail Roof-molding.
161. Upper-deck Bottom-rail Head-lining Molding.
162. Upper-deck Top-rail.
163. Upper-deck Eaves-rail.
164. Deck-post or Muntin.
165. Upper-deck Hood.
166. Upper-deck Hood-bow.
167. Upper-deck Sash-rail.
168. Lower-deck Sash-rail.
169. Upper-deck Corner-post.
170. Ventilator-sash Pivot.
171. Upper-deck End-transom.
172. Transom Pivoted-sash.
172a. Top-transom Glass.
173. Transom Stationary-light.
174. Transom-rafter.
175. Transom Head-lining Blocking.
176. Corner Transom-muntin or Mullion.
177. Center Transom-muntin or Mullion.
178. Upper Transom-finish Molding.
179. Transom-casing.
180. Advertising-rack Rail.
181. Upper Advertising-molding.
182. Lower Advertising-molding.
183. Head-lining.
184. Crown-molding.
185. Hand-pole.
186. Hand-pole Straps.
187. Hand-pole Bracket.
188. Hand-pole Tip.
189. End-lining.
190. Face-board Circle.
191. Door-sheave Transom.
192. End-lining Hinged-sash.
193. Hinged-sash Bar.
194. Mirror.
195. Cripple-post.
196. End-lining Panel (glass).
197. Signal-bell.
198. Signal-bell Cord.
199. Pedal Alarm-gong.
200. Alarm-gong Hammer.
201. Alarm-gong Button.
202. Center-lamps.
203. Lamp-jack.
204. Headlight.
205. Headlight-clip.
206. Fare-register.
207. Fare-register Block.
208. Car-stove.
209. Stove-box.
210. Stove-pipe.
211. Smoke-jack.
212. Roof-collar.
213. Stove-box Top-plate.
214. Stove-box Cross-bar.
215. Stove-box Side-bar.
216. Brake-handle.
217. Brake-pawl.
218. Brake-shaft.
219. Upper Brake-shaft Bearing.
220. Lower Brake-shaft Bearing.
221. Brake-shaft Ratchet-wheel.
222. Brake-shaft Chain.
223. Brake-shaft Stirrup.
230. Lower Fulcrum-bracket.
231. Middle Fulcrum-bracket.
232. Left-hand Lever.
233. Right-hand Lever.
234. Top-roller.
235. Top-roller Housing.
236. Transverse Connecting-bar.
237. Swivel-attachment for Adjustment.

(Continued.)

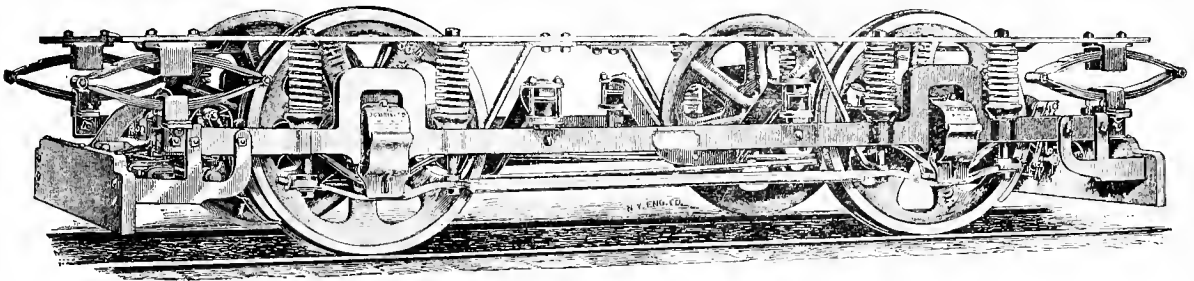

Fig. 5668. TRUCK FOR STREET CARS. J. G. BRILL COMPANY.

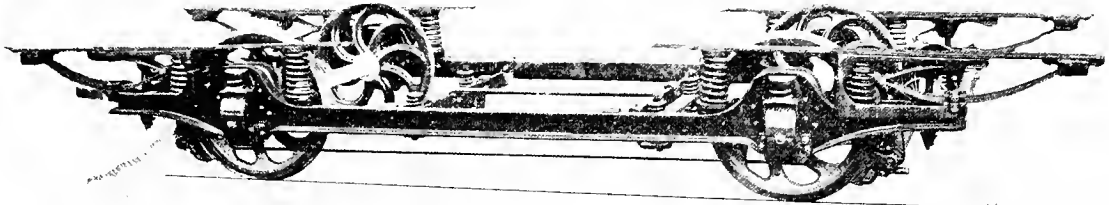

Fig. 5669. THE MCGUIRE COLUMBIAN TRUCK, WITH FOX PRESSED-STEEL FRAME.

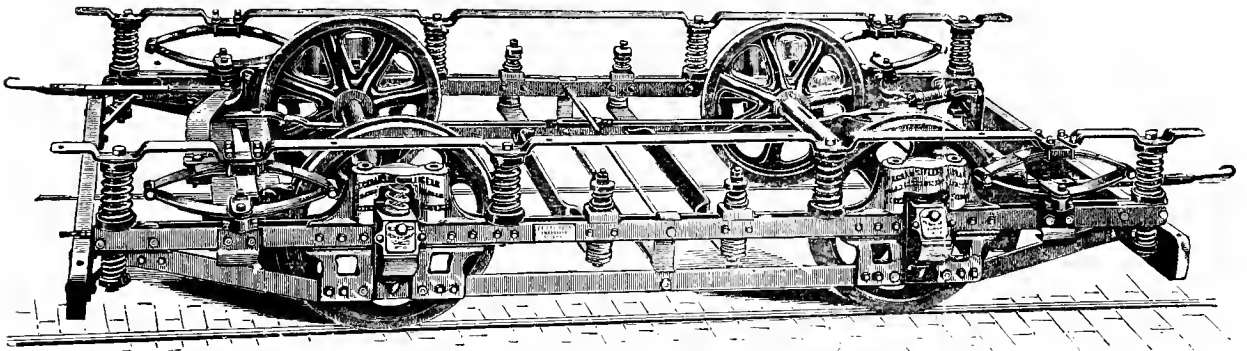

Fig. 5670. TRUCK FOR STREET-CARS. THE PECKHAM STANDARD.

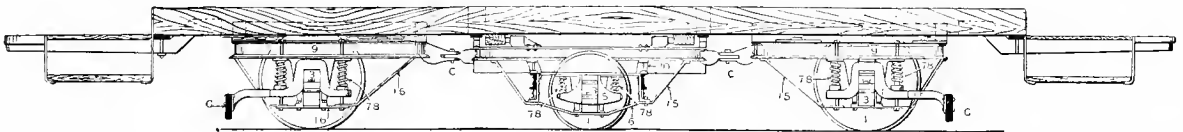

Fig. 5671. Side Elevation.

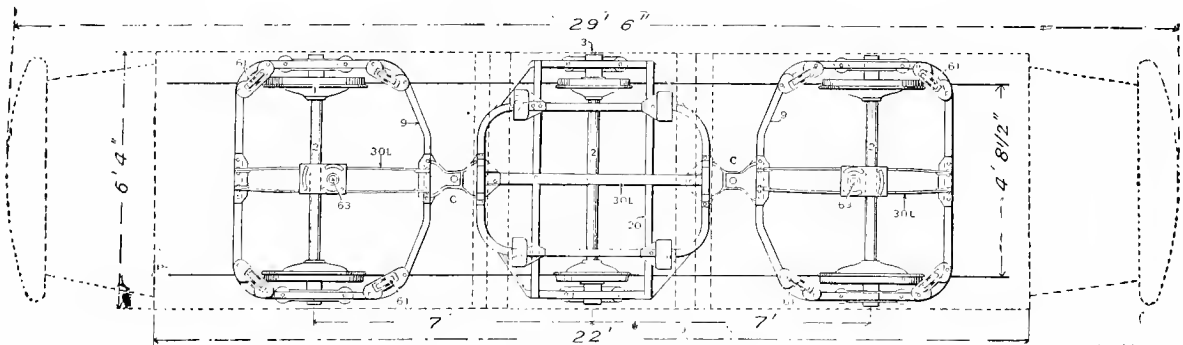

Fig. 5672. Plan of Truck on a Tangent.

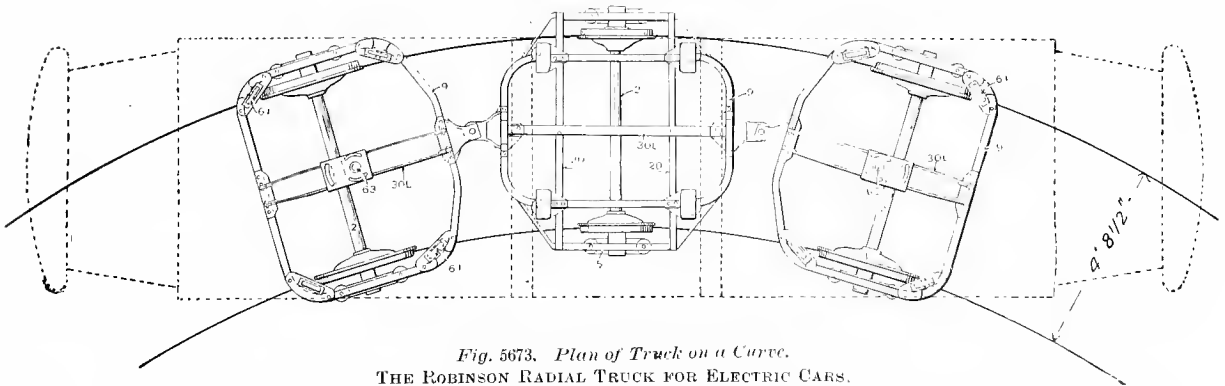

Fig. 5673. Plan of Truck on a Curve.

THE ROBINSON RADIAL TRUCK FOR ELECTRIC CARS.
 (Other styles of trucks are shown in General Views of Street Cars.)

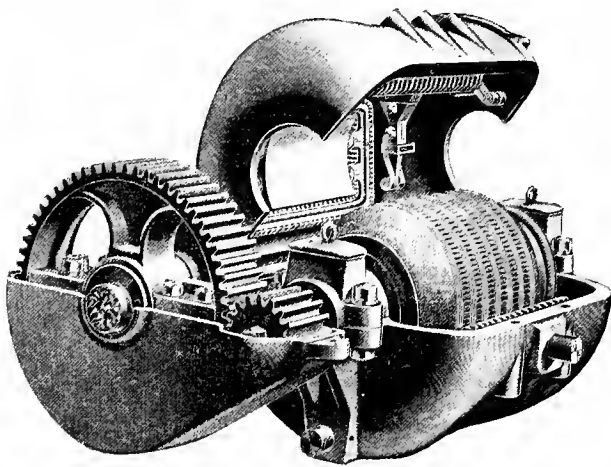

Fig. 5674. MOTOR-CASE AND ATTACHMENT TO AXLE.

THE WALKER MANUFACTURING COMPANY.

Motor is suspended on Spiral Springs from the Axle and Frame.

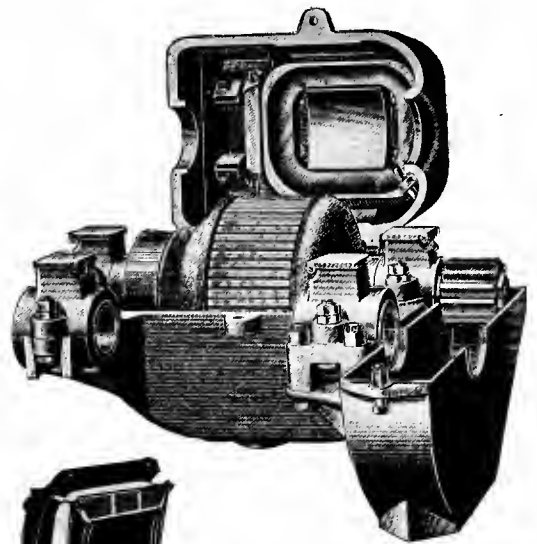

Fig. 5675. MOTOR-CASE AND ATTACHMENT TO AXLE.

GENERAL ELECTRIC COMPANY.

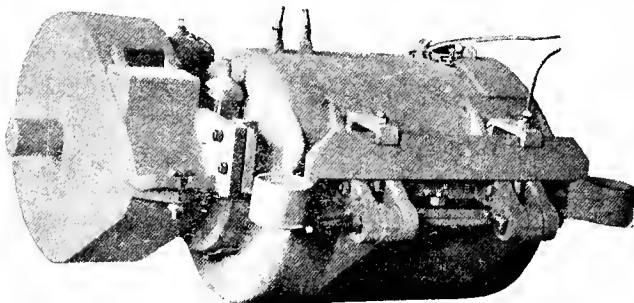

Fig. 5676. MOTOR INCLOSED, HUNG UPON AXLE.

CARD ELECTRIC COMPANY.



Fig. 5677. MOTOR-CASE AND ATTACHMENT TO AXLE.

WESTINGHOUSE ELECTRIC COMPANY.

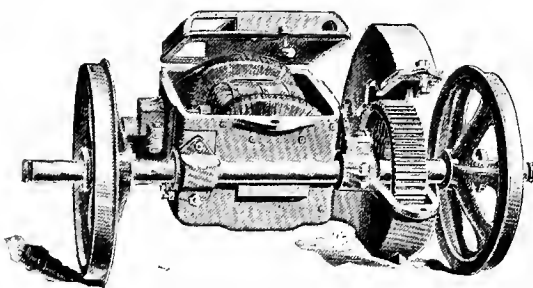

Fig. 5678. MOTOR ATTACHED TO A PAIR OF WHEELS, WITH CASE OPEN TO SHOW ATTACHMENT.

CURTIS ELECTRIC COMPANY.

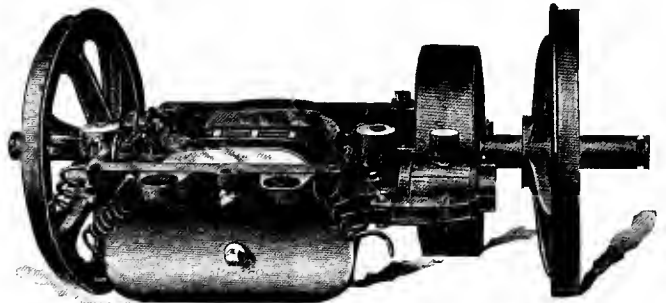

Fig. 5679. MOTOR ATTACHED TO A PAIR OF WHEELS.

STEEL MOTOR COMPANY.

TYPES OF ELECTRIC-MOTORS FOR STREET-RAILWAY CARS.
Showing several methods of Attaching the Motors to Car Axles.

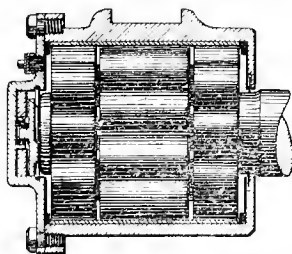

Fig. 5680. Sectional Side Elevation.

THE MENEELY TUBULAR-ROLLER JOURNAL-BEARING.

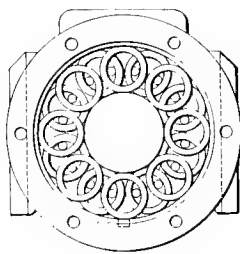

Fig. 5681. Sectional End Elevation.

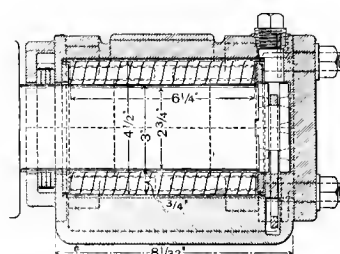

Fig. 5682. Sectional Side Elevation.

THE HYATT FLEXIBLE-ROLLER JOURNAL-BEARING.

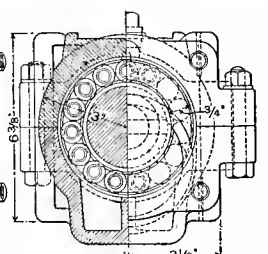

Fig. 5683. Sectional End Elevation.



CARS AND TRUCKS



PPROMOTERS AND BUILDERS of Electric Roads, as well as officials of roads already in operation, must sooner or later devote some time and attention to Rolling Stock. This is, therefore, a fitting opportunity to display a number of illustrations of Cars and Trucks built by J. G. Brill Company. The illustrations show varied styles of cars, suitable for the different climates and requirements, as well as some specially designed cars for private use, and centre-vestibule compartment cars such as designed by J. G. Brill Company and used in St. Louis.

To all parties interested in Electric Roads a perusal of the following pages may not only be interesting but a benefit.

Detailed information, prices, etc., can be obtained from

Western Office

1038 Monadnock Bldg., CHICAGO

J. G. BRILL COMPANY

PHILADELPHIA



CLOSED CARS

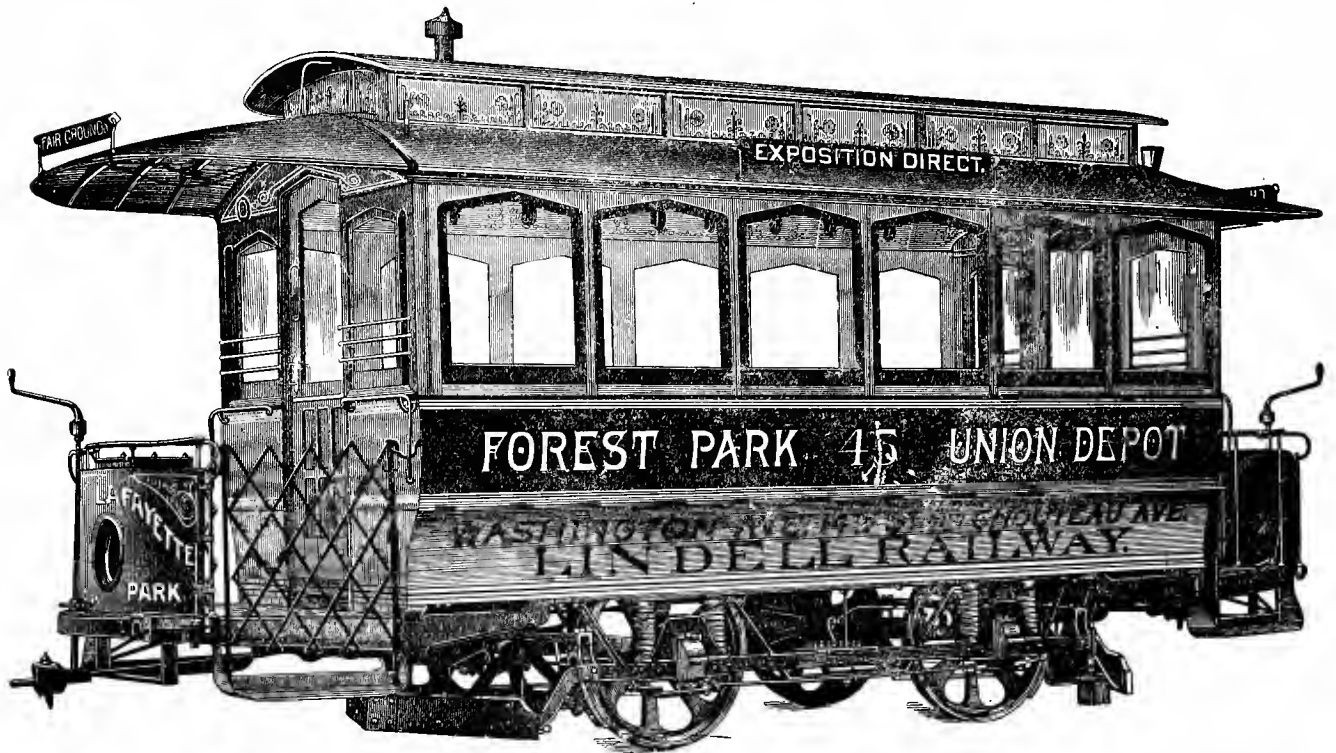

Standard 16 ft. Electric Motor Car Body. Inside finish can be made, as desired, in palace No. 1, 2 or 3. Car body illustrated is mounted on a truck, first-class at the time furnished, but not possessing the advantages of Brill No. 21-B. To illustration and description following attention is respectfully called.

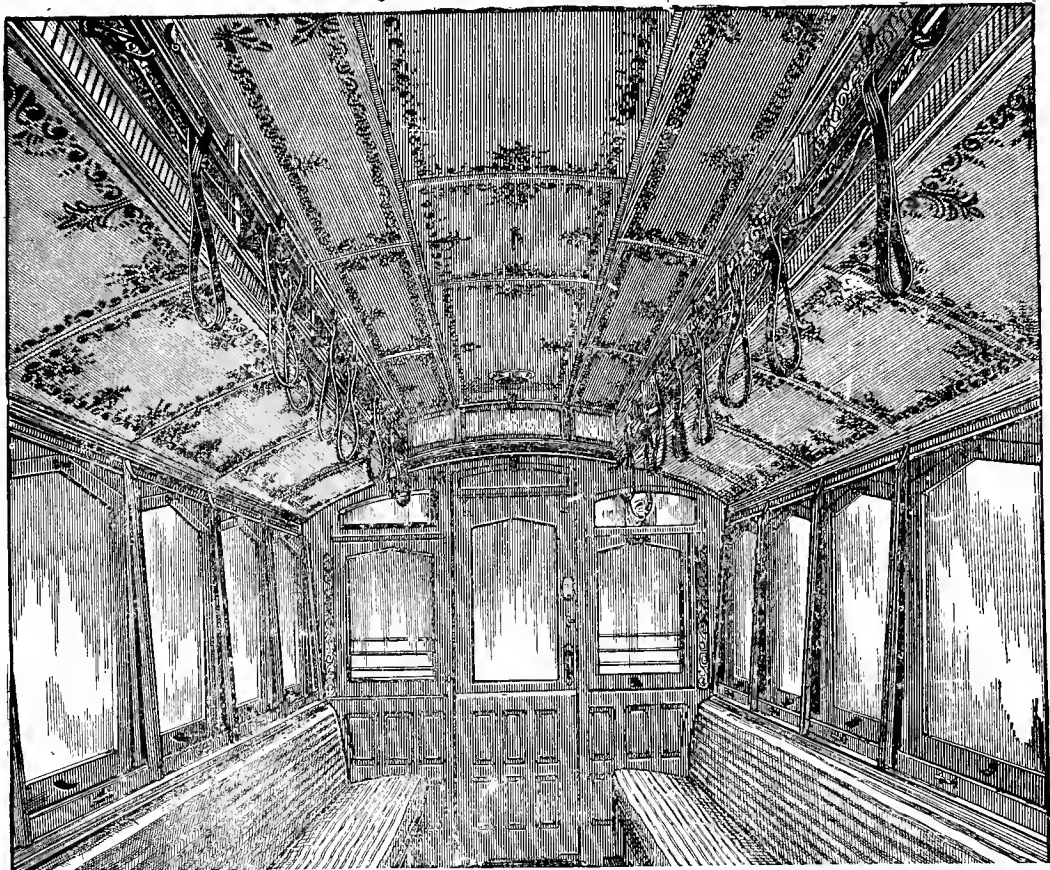

Inside Seating Arrangement of above car, showing Style of Finish.

TRUCKS

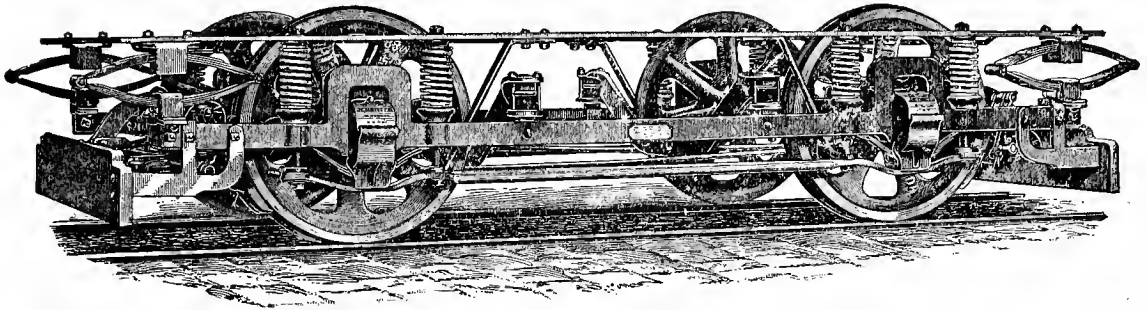

Brill No. 21-B Electric Motor Truck. Is rigidly attached to the car body, and by the system of springs used overcomes all oscillation.

Axle-box frame (see cut below) is entirely a solid forging, free from bolts, nuts and rivets; nothing to rattle loose and require attention and repairs, thereby contrasting strongly with trucks having frames composite, built up of a multiplicity of parts and always requiring more or less attention.

No. 21-B Truck has springs under the journal-boxes, cushioning the blow to rail joints, special work, etc., when the vehicle passes over them.

For simplicity of construction, ease of riding, solidity and slight cost of maintenance, Brill No. 21-B Truck stands far ahead of all competition.

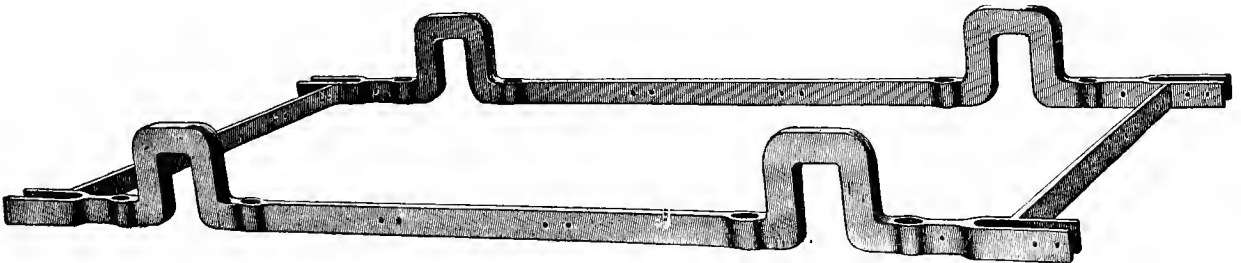

The axle-box frame of Brill Trucks, a *solid forging*, one piece, no bolts, no nuts, no rivets, no steel or malleable castings.

CLOSED CARS

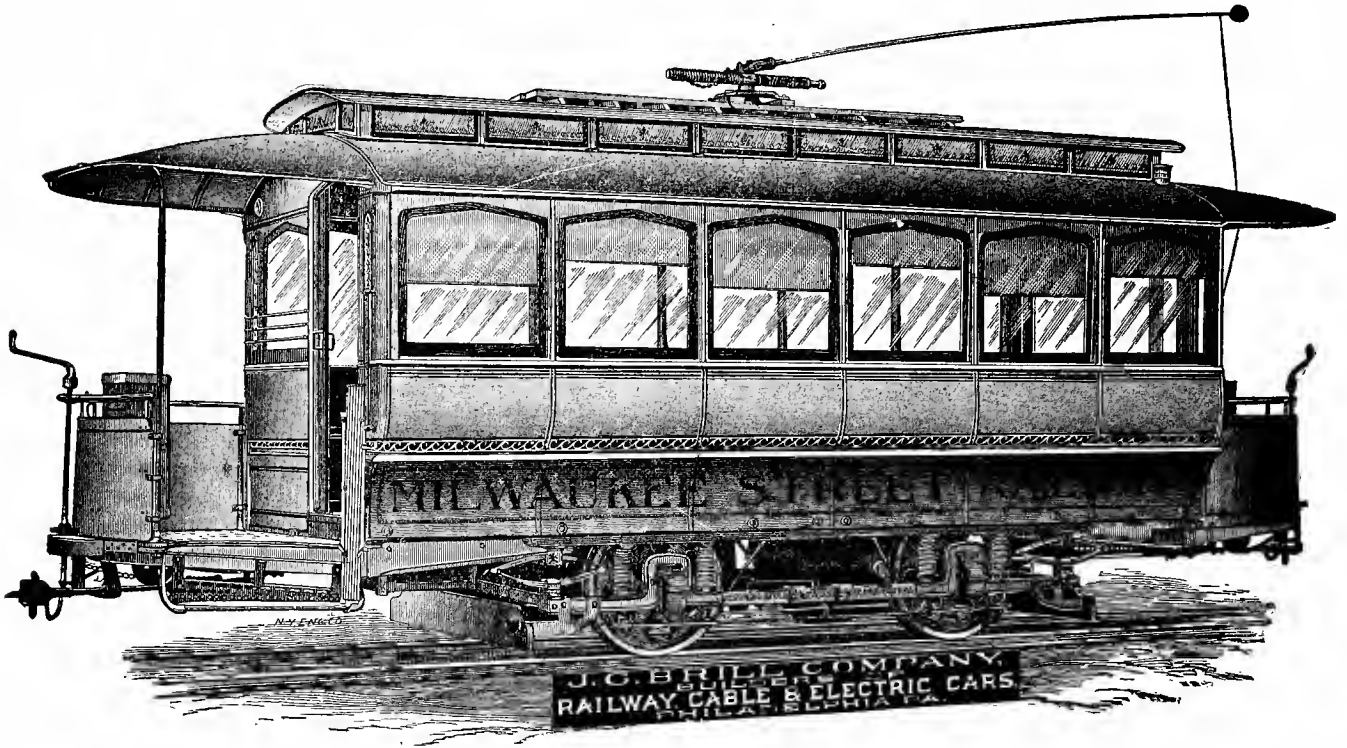

Standard 18 ft. motor body mounted on Brill No. 21 Truck. Arranged with dasher, closed at one side and doors at diagonal opposite corners, facilitating loading and unloading. This type of car is used largely in Buffalo, N. Y., Camden, N. J., and other places, with excellent results. Inside finish can be made, as desired, palace No. 1, 2 or 3.

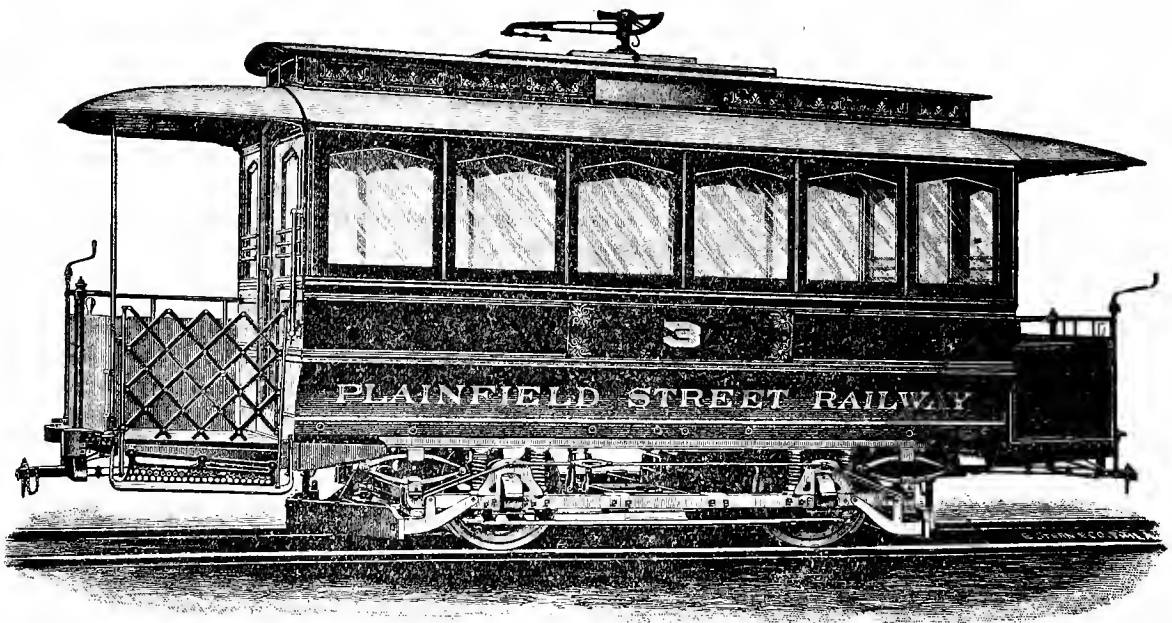

Standard 18 ft. Motor Body, mounted on Brill No. 13 Truck, identically same as car above, excepting doors are in centre of each end.

CLOSED CARS

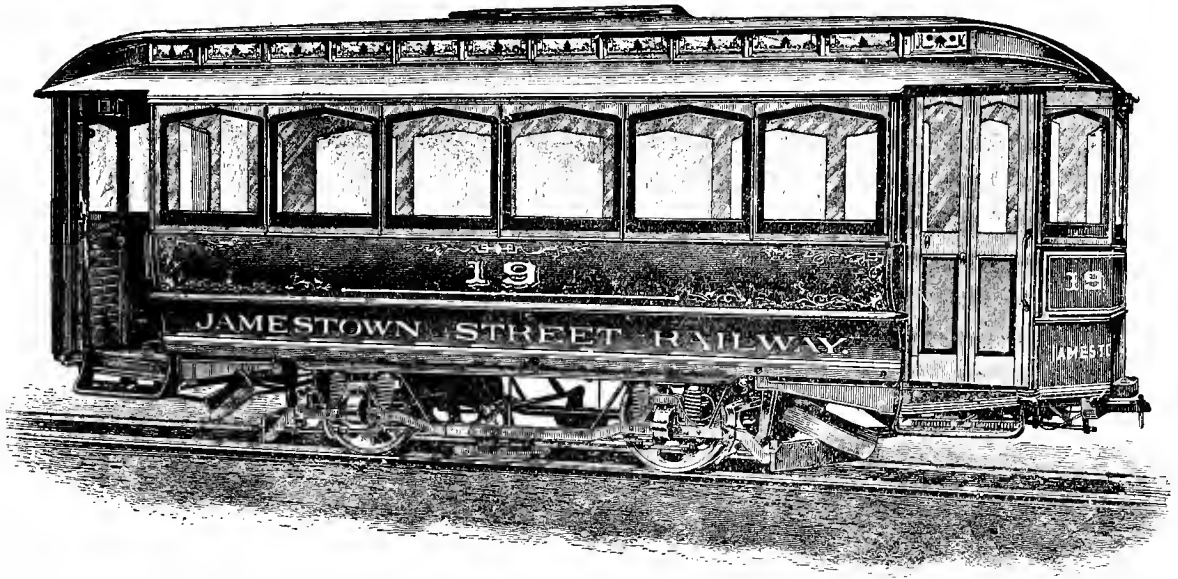

Standard 18 ft. motor body, mounted on Brill No. 7 truck, but suitable for mounting on Brill No. 21-B truck. Has full monitor deck extending over platforms. Platforms are vestibuled and fitted with folding doors, making perfectly tight compartment for motorman. Finish can be, as desired, No. 1, 2 or 3.

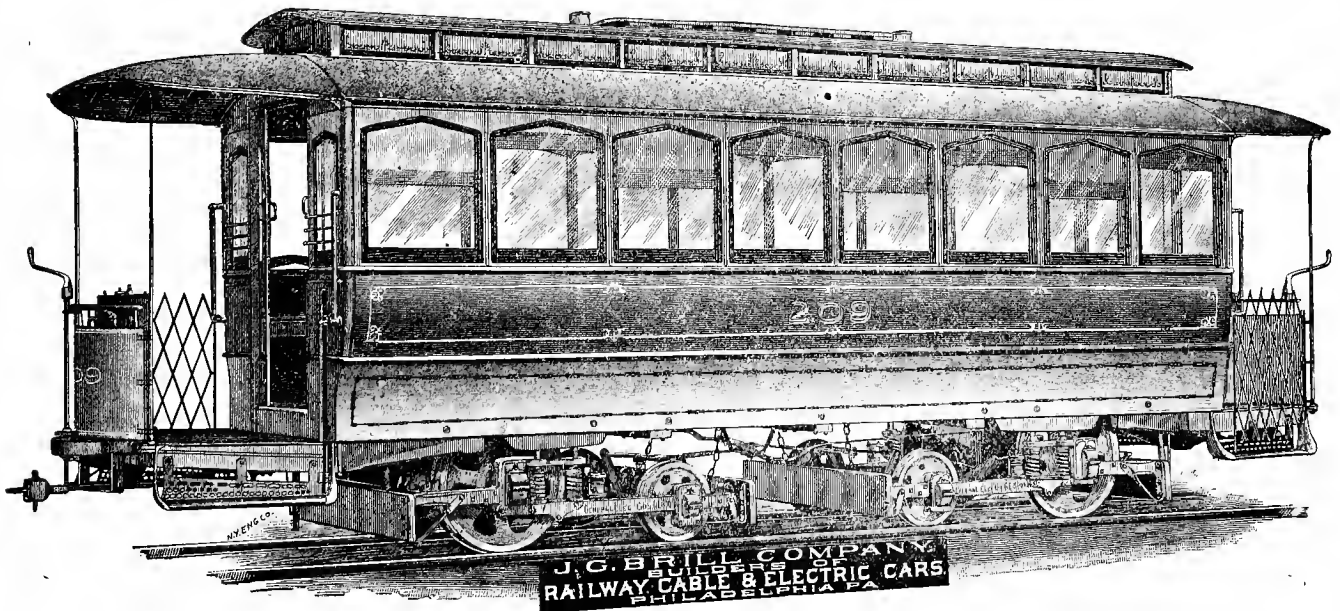

Standard 20 ft. motor body, with open platforms, double doors, etc. Mounted on "Eureka" Maximum-Traction Tracks (as per following illustration and description). Finish can be, as desired, No. 1, 2 or 3. This is the style of car adopted by the New Orleans Traction Company who have upwards of 200 in operation.

TRUCKS

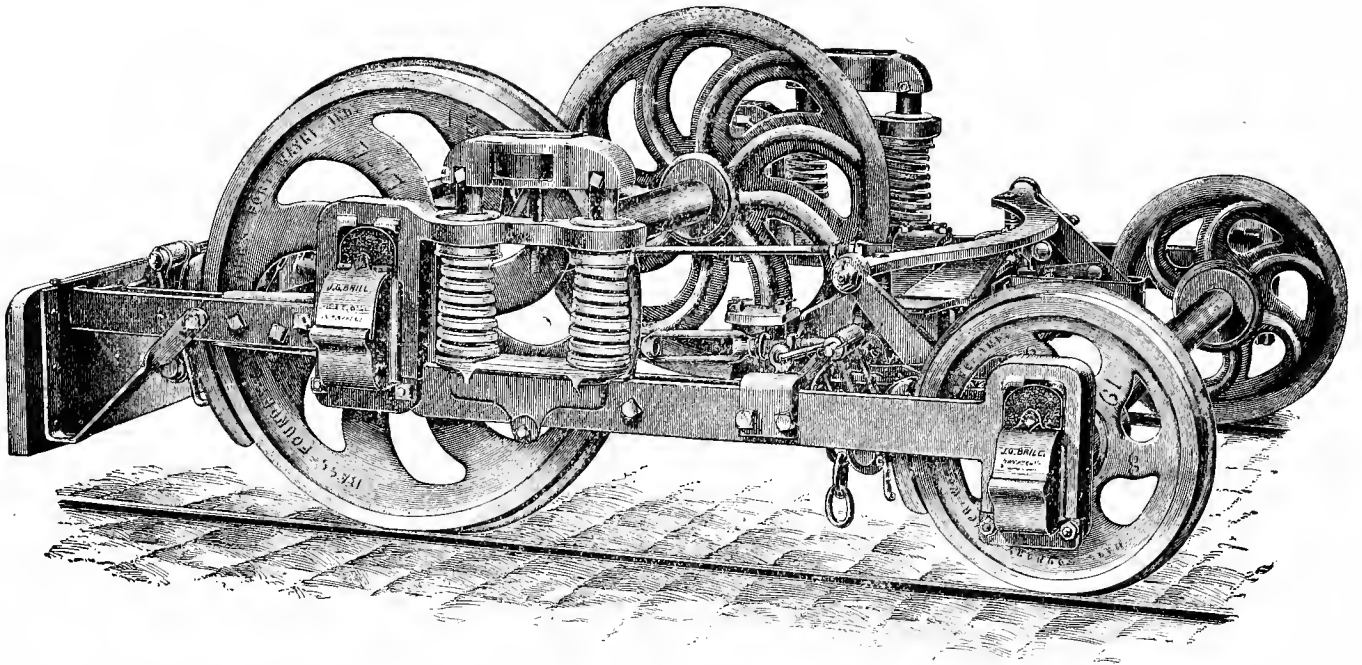

Brill's "Eureka" Maximum-Traction Pivotal Truck, having 33 in. driving-wheels, and resting the car body 27 $\frac{1}{4}$ in. from rail to underside of sill, 87 per cent of the weight of car body, load and motors comes on the driving-wheels, greatly increasing the tractive force of the truck, and utilizing almost all the electric energy. Side bars are a solid piece, free from bolts and nuts. Spring compression device on rear of truck to throw weight on rear wheels when truck radiates on going through curves. Increased effectiveness of brakes, as eight points of friction are presented. Is easier on roadbed, as there is no oscillation; the motion of a double-truck car, as against a single-truck car, is a rolling weight versus a pounding weight.

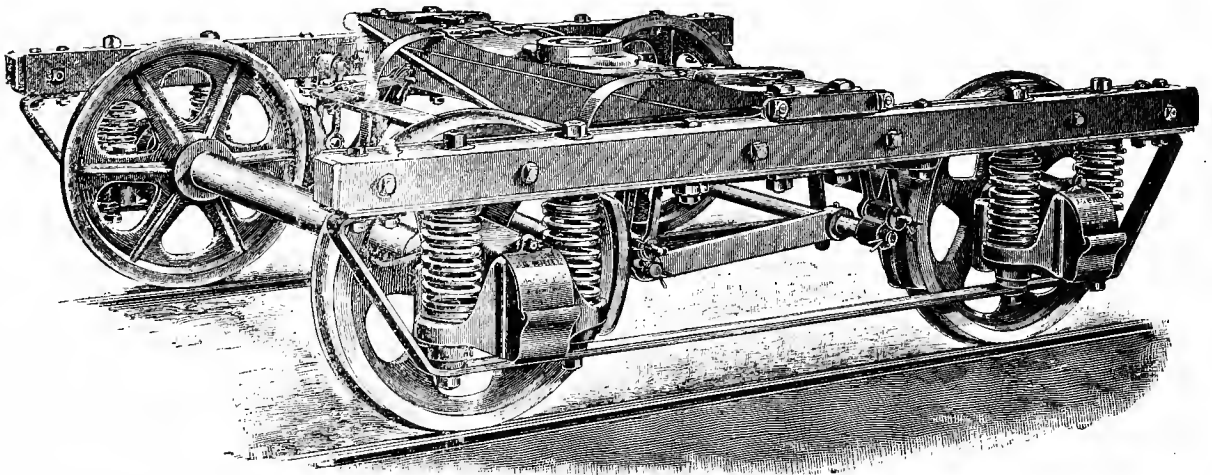

Trail Truck. Where it is desired to operate a car with one motor and "Eureka" truck, for the saving in expense, a trail truck, as above, can be used under rear end of car.

CLOSED CARS

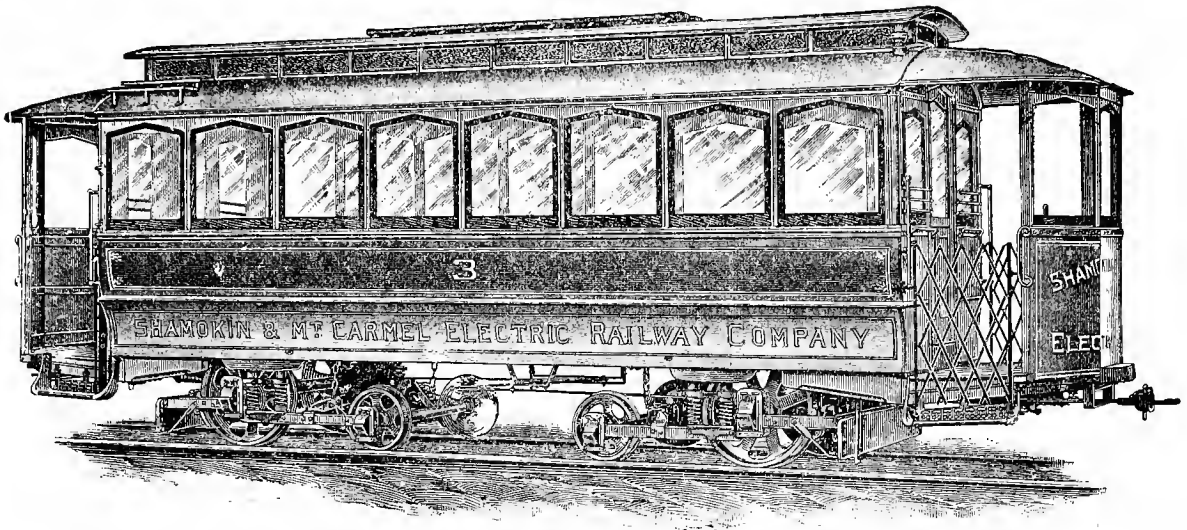

Twenty-two feet Vestibuled Motor Car Body, mounted on Brill's "Eureka" Trucks. Identically similar to car No. 209, page 5, except two feet longer in body and equipped with vestibules on platforms.

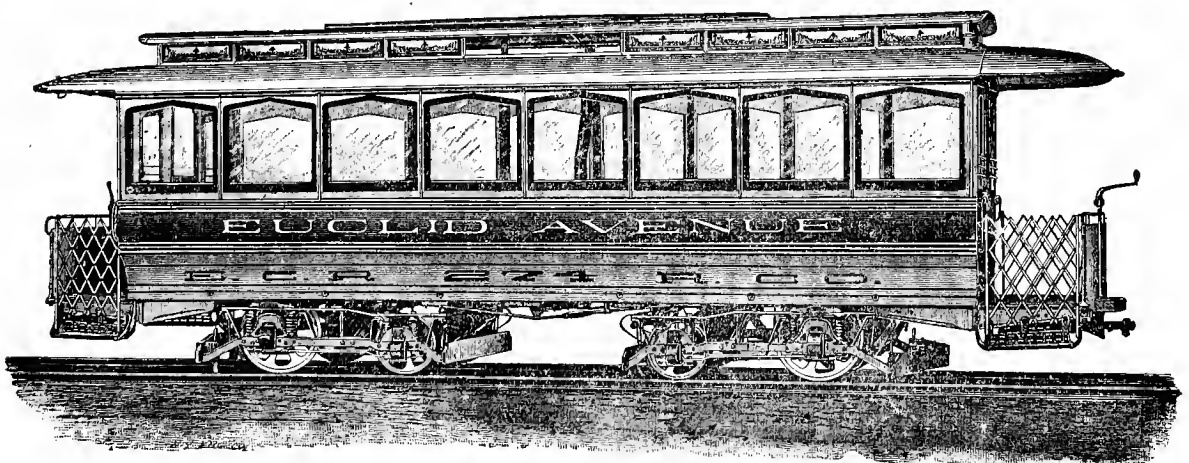

Twenty-five feet Motor Body, with open platforms and mounted on Brill's Maximum-Traction Trucks. Finish can be made, as desired, No. 1, 2 or 3.

CLOSED CARS

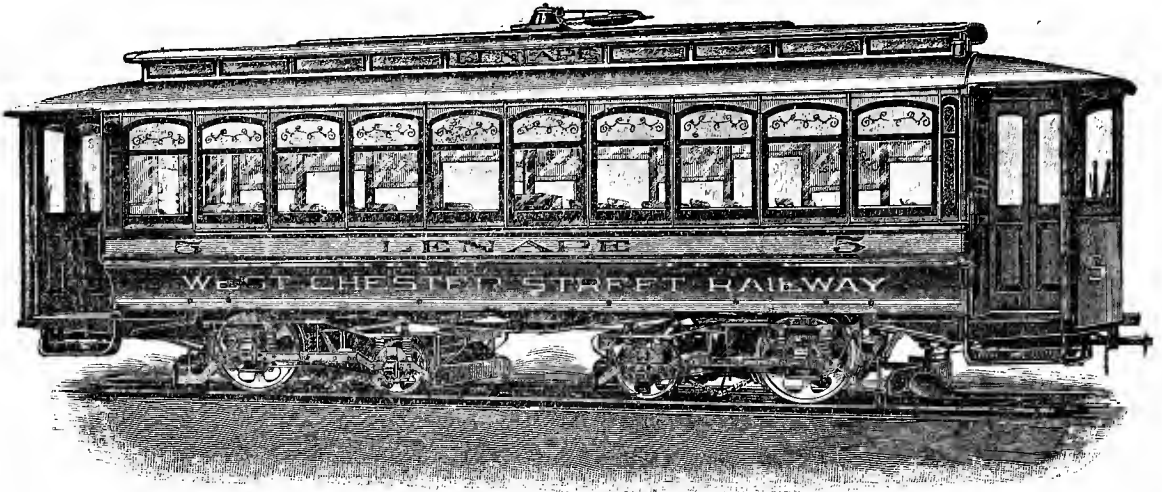

Twenty-five feet six inches Motor Body, having vestibuled ends, with doors and transverse seats and aisle through center. Sash double on each side, top sash stationary, bottom sash arranged to lower, flush with window rail.

Specially advantageous on inter-urban lines, where in almost all cases passengers desire to face the direction in which car is running. Is equipped with Brill's patented seat arms, saving room and decreasing the width of car and consequently the cost of construction. Finish can be No. 1, 2 or 3, as desired. Mounted on Brill's Maximum-Traction Trucks.



Showing Interior Seating Arrangement of the above Car

CLOSED CARS

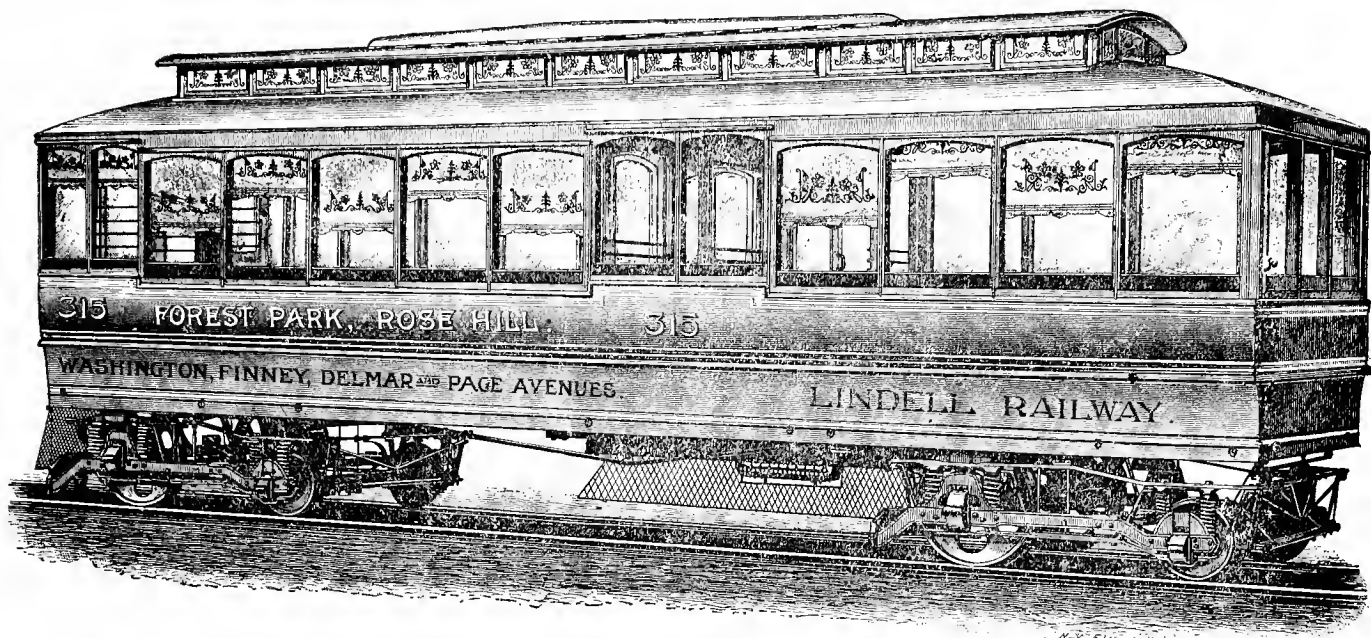

One View of Patented Center Vestibule Compartment Car.

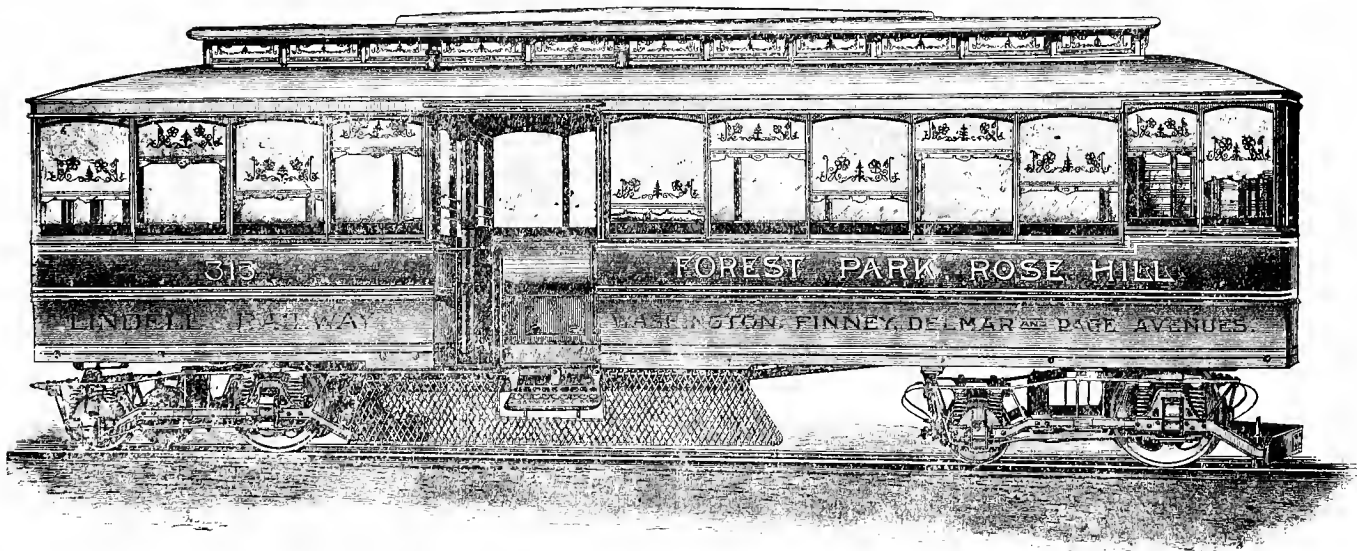

Another View of Center Vestibule Compartment Car, showing Entrance.

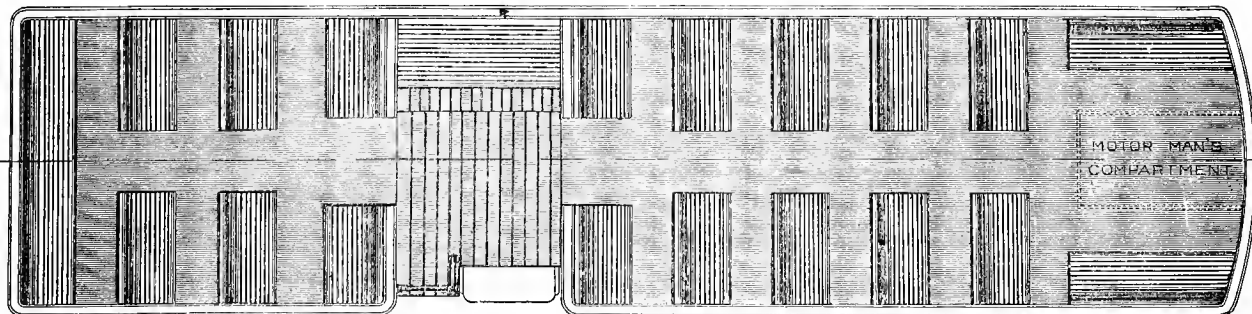

Showing Seating Arrangement of Center Vestibule Compartment Car.

Car specially designed for Lindell Ry. Co., St. Louis, and used quite largely by them. Embodies the advantage of separate compartments—one for smokers and one for regular passengers. Finish of both compartments can be, as desired, No. 1, 2 or 3. Car mounted on Brill's Maximum-Traction Trucks.

OPEN CARS

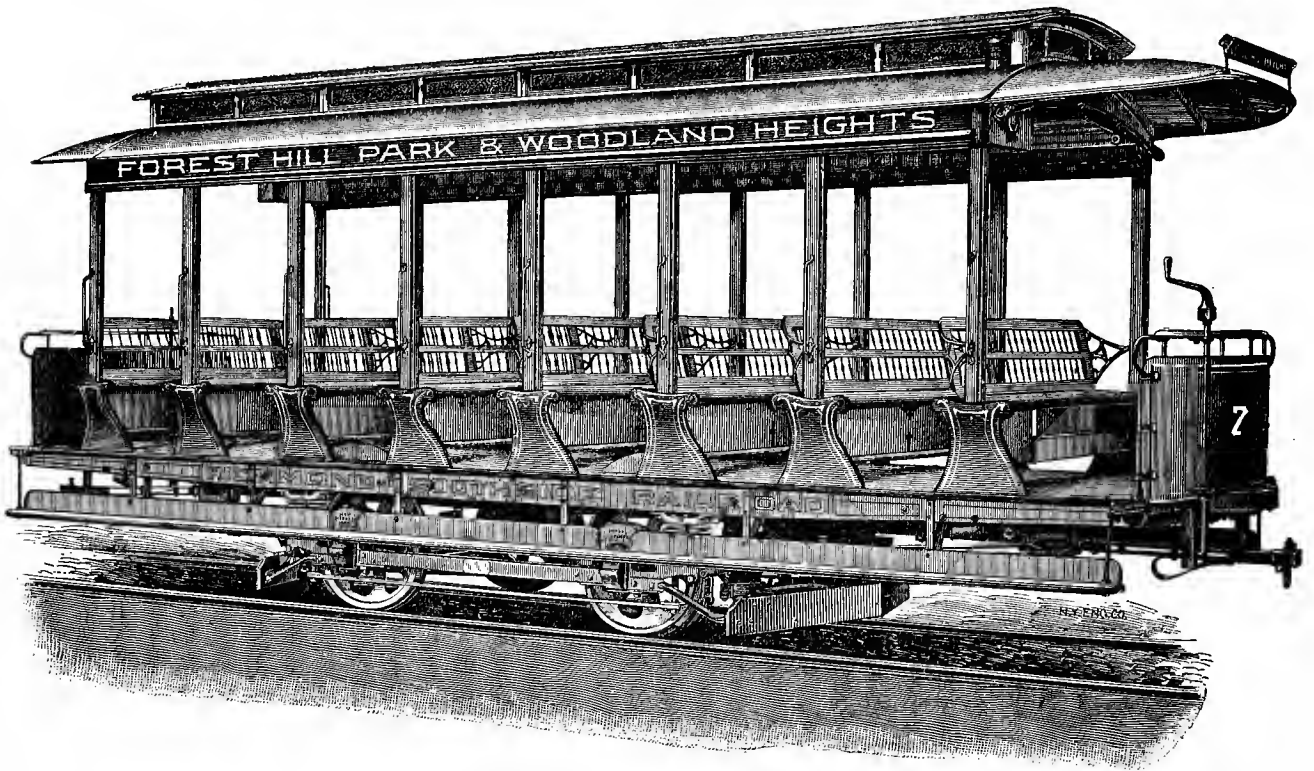

Standard 8-Seat Open Motor Body, mounted on Brill No. 12 Truck, and arranged for Brill No. 21 B Truck. Has monitor deck roof full length of body. Spindle back seats, spring roller curtains, etc. Finish can be No. 1, 2 or 3, as desired.

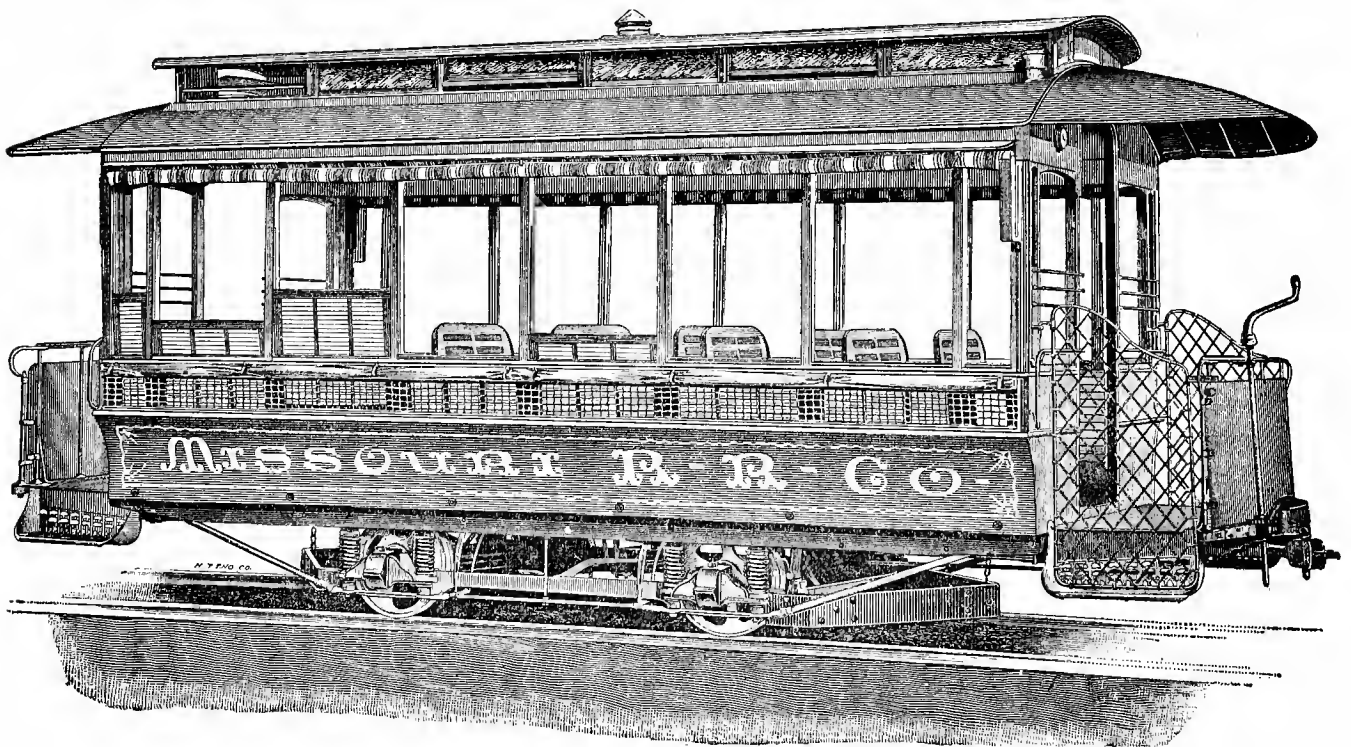

Eighteen feet Convertible Car Body, designed for mounting on electric motor truck, but shown as a trail car on running gear. Seats are arranged transversely of car and aisle through center. In winter panels and glass are fixed stationary in the openings between posts and over screens, making an air-tight car. Finish can be No. 1, 2 or 3, as desired.

OPEN CARS

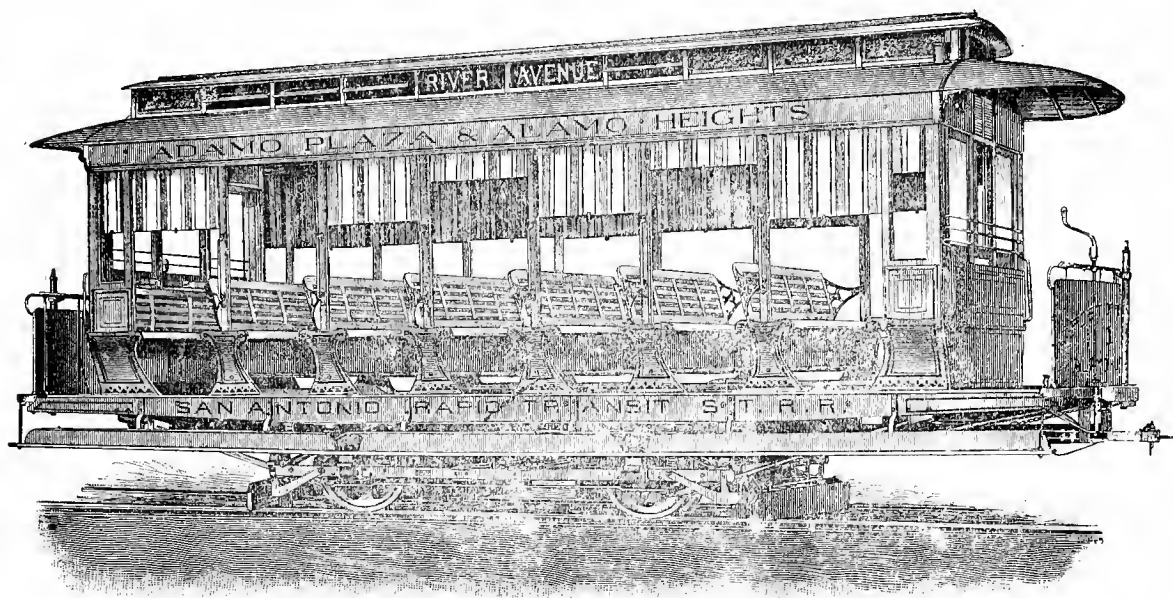

Standard Eight-seat Open Car, having enclosed front ends, with sash. Monitor deck roof full length of body. Spring roller curtains, solid seat backs. Finish can be No. 1, 2 or 3, as desired. This car can be arranged having seats on platforms (see cut below) by lengthening the platforms 13 in. each. Mounted on Brill No. 13 truck.

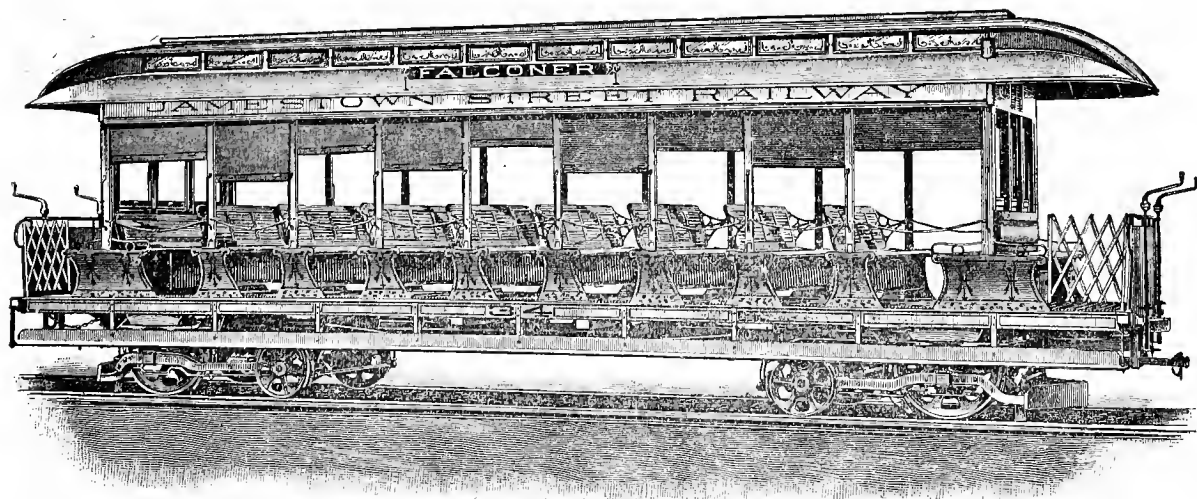

Twelve-seat Open Car, mounted on Brill Eureka Maximum-Traction Truck. Spring roller curtains, monitor deck extending over platforms. Bulkheads in ends, with sash, seats on platforms. Length, 34 ft.; seating capacity, 60 passengers.

DOUBLE-DECK CARS

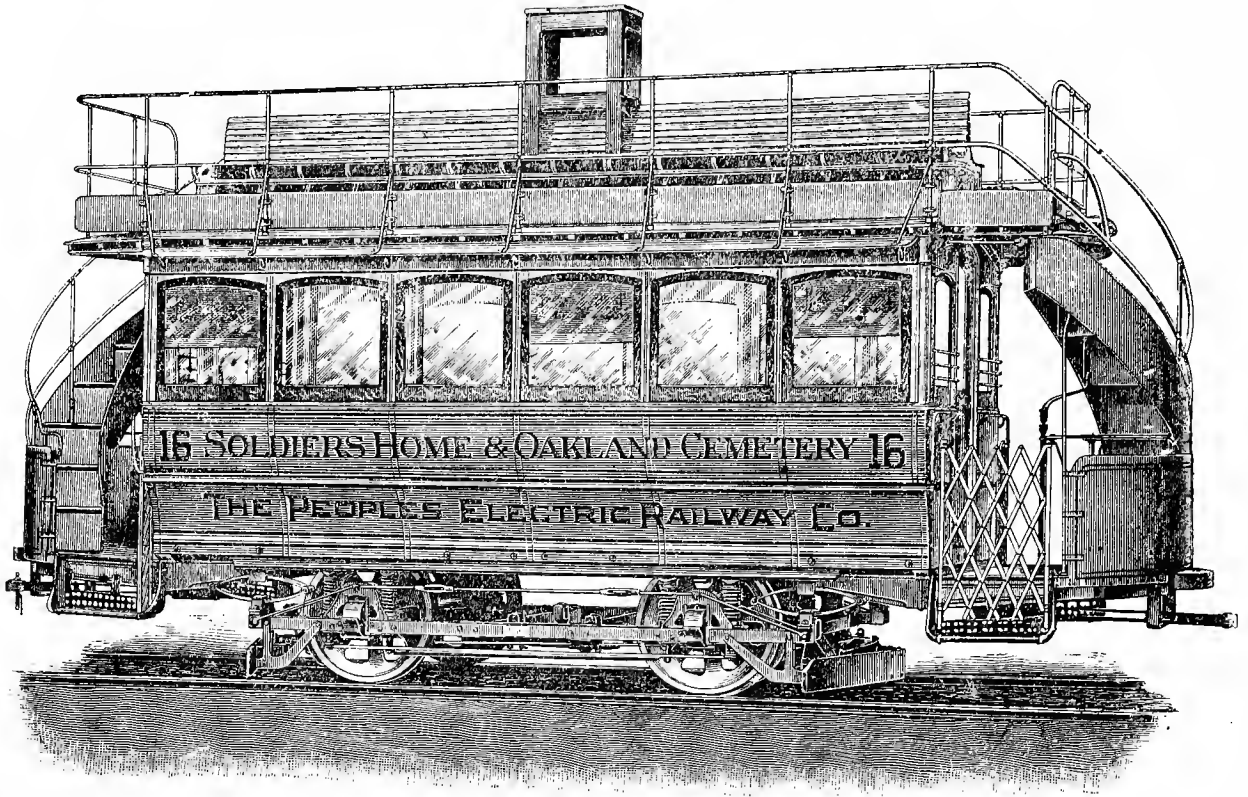

Sixteen-foot Double-deck Car, without canopy, but having pedestal in center for support of trolley apparatus. Stairway at each end. Mounted on Brill No. 13 truck. Finish inside can be No. 1, 2 or 3, as desired.

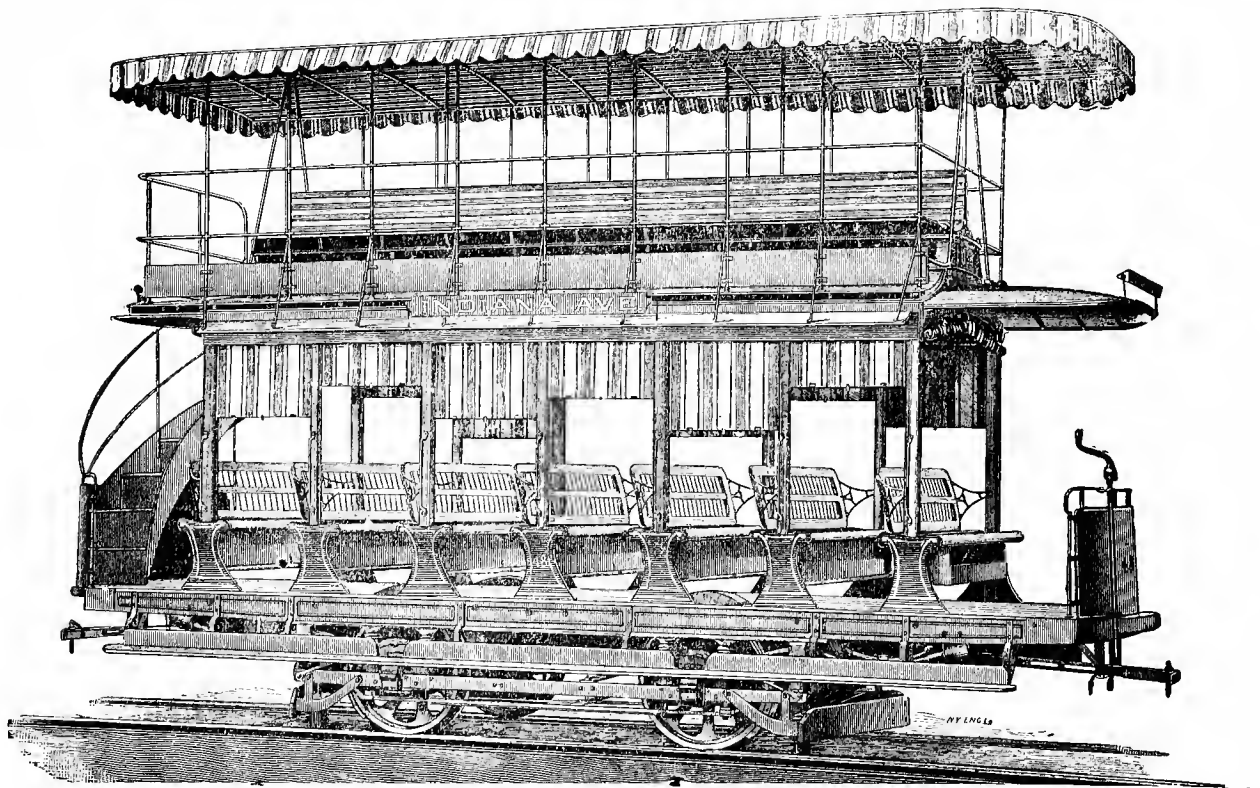

Seventeen-seat Open Car, double-deck, with stairway at one end and with canopy. Spindle-back seats in lower deck, spring roller curtains, etc. Finish can be No. 1, 2 or 3, as desired. Mounted on Brill No. 13 truck.

DOUBLE-DECK CARS

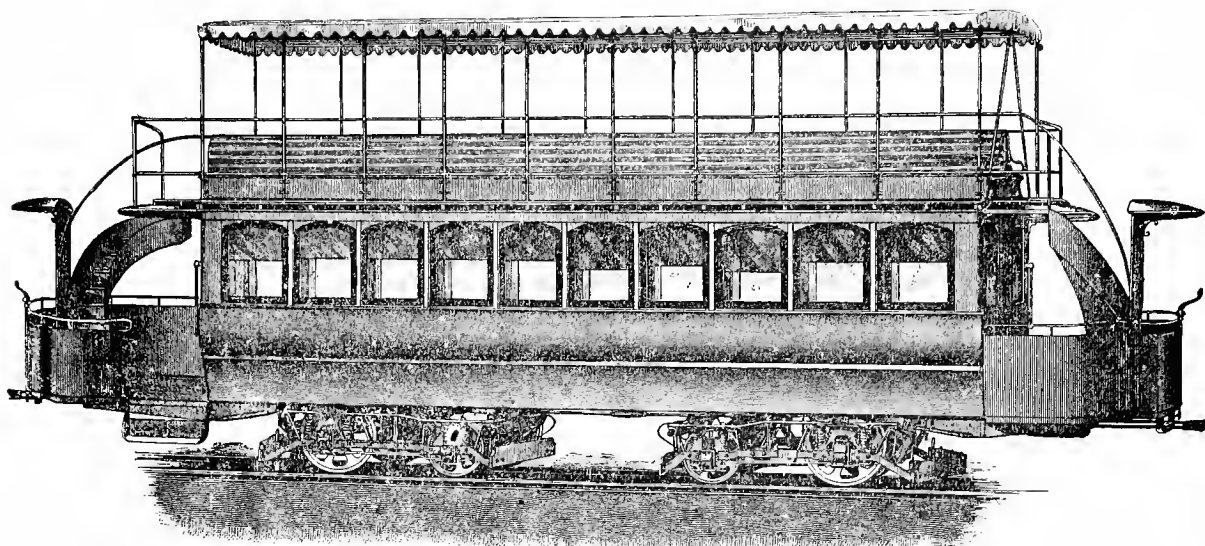

Twenty-five feet Double-Deck Car, with auxiliary motorman's platform. Double-deck canopy and stairway at each end. Finish inside can be No. 1, 2 or 3, as desired. Car mounted on Brill's Maximum-Traction Trucks.

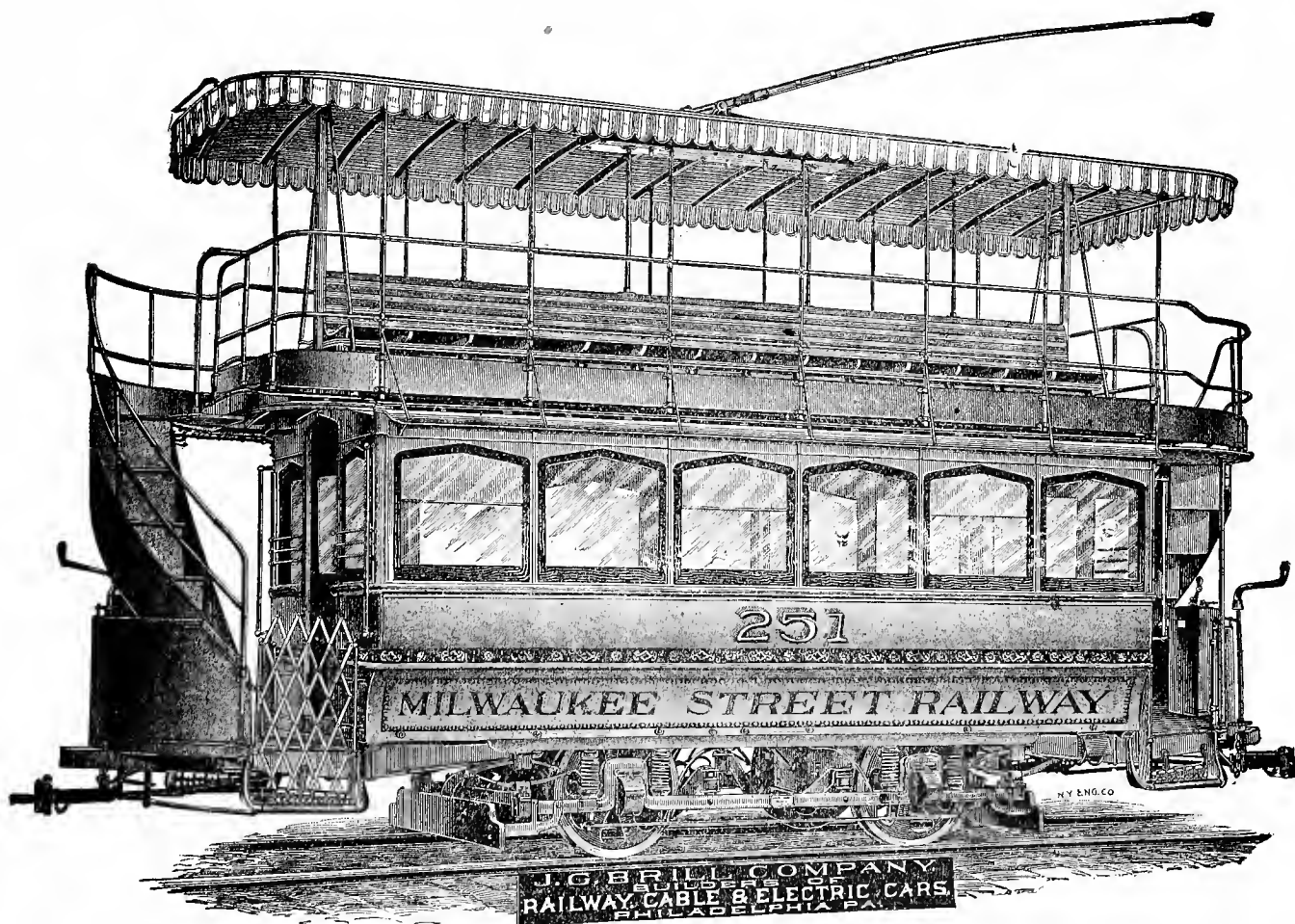

Eighteen feet Double-Deck Car, with canopy and stairway at each end. Stairway specially designed with less pitch, allowing room under stairway for motorman and electrical controlling devices. Mounted on Brill No. 21 Truck.

DOUBLE-DECK CARS

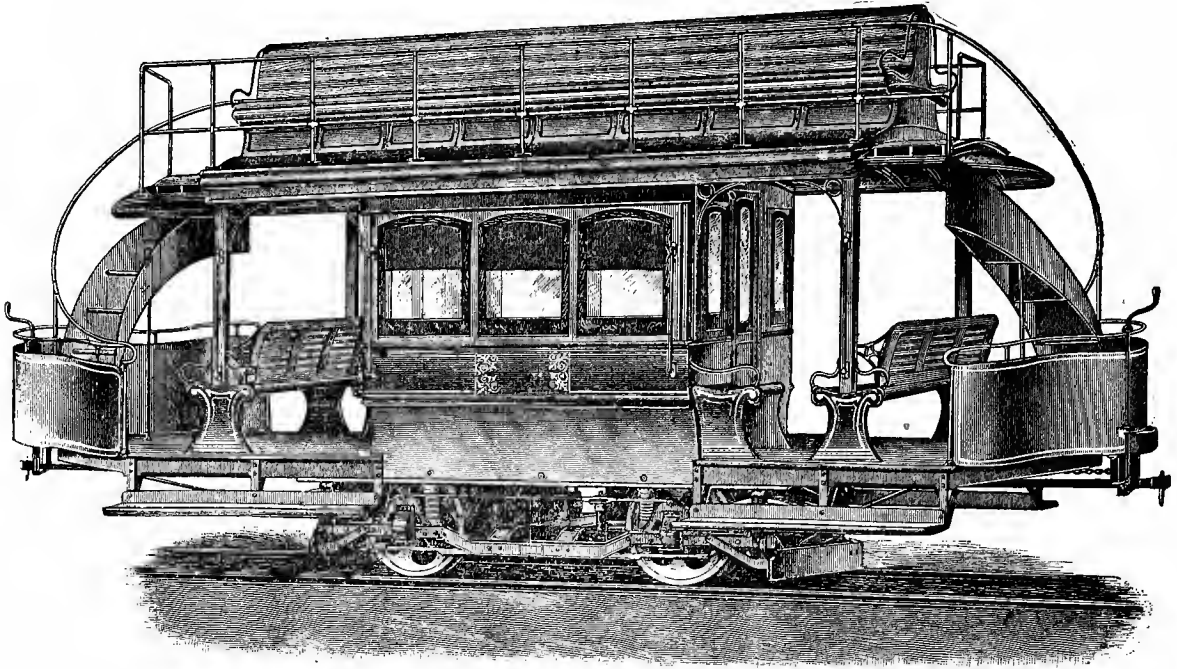

Combination Open and Closed Double-Deck Car. Compartments can be made any length and any finish desired. Stairways at each end, and can be arranged with canopy if desired. Mounted on Brill No. 13 Truck.

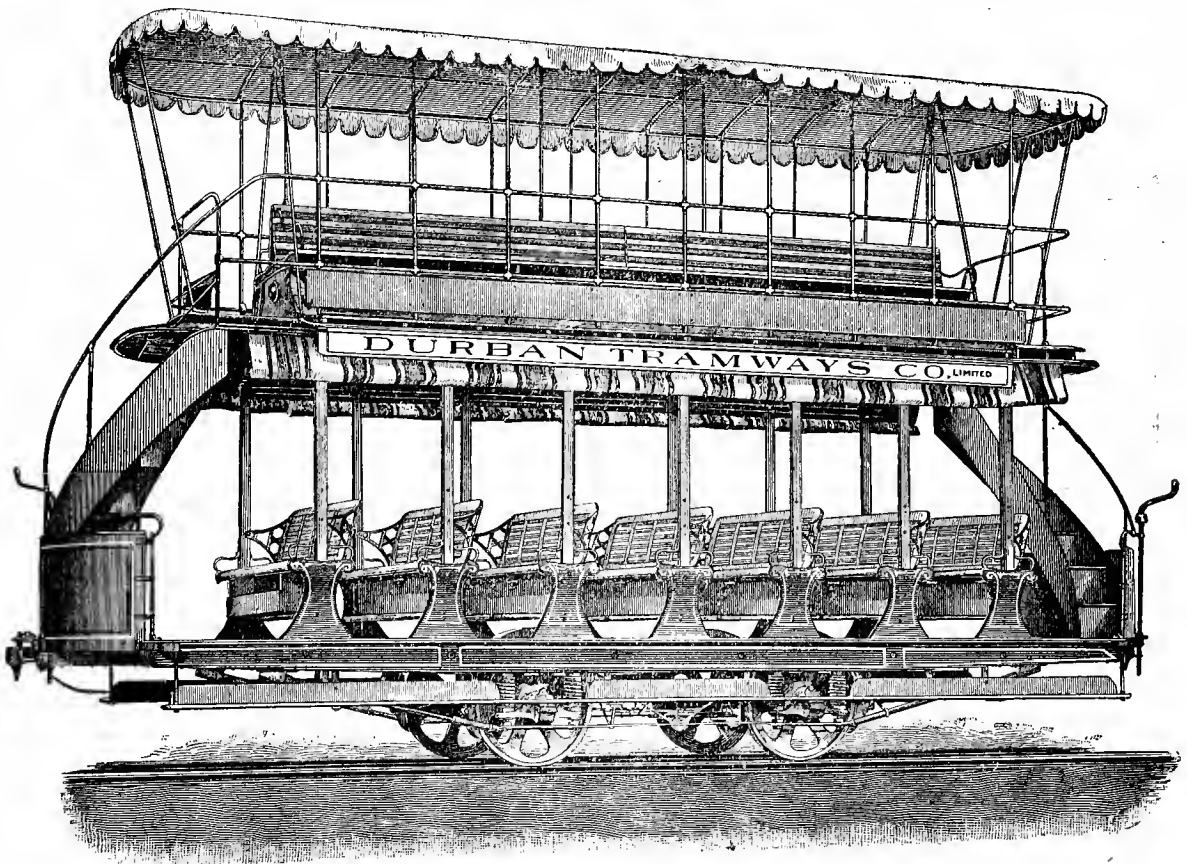

Seven-Seat Open Car with Double Deck and Canopy. Stairways at each end. Finish can be as desired, and car can be mounted on Brill No. 21-B Truck, and operated as a motor car or on running gear as a trail-car.

COMBINATION BAGGAGE AND PASSENGER CARS

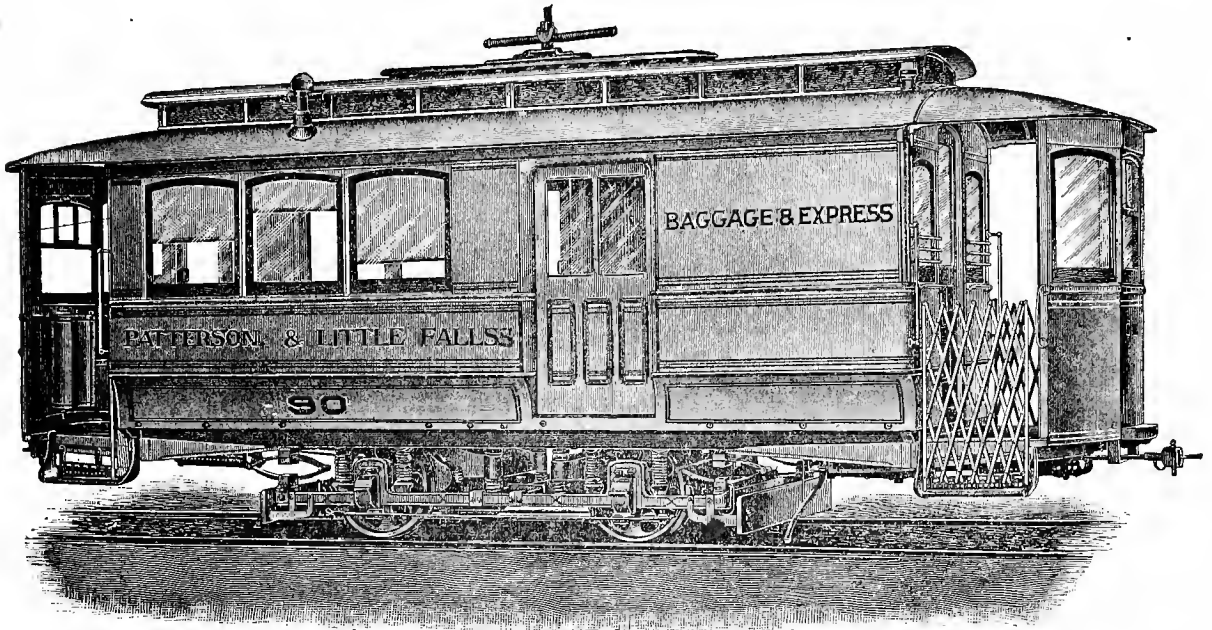

Twenty-foot Combination Passenger and Baggage Car, having compartments of equal length and Vestibuled ends. Finish to passenger compartment can be, as desired, No. 1, 2 or 3. Mounted on Brill No. 21 Truck.

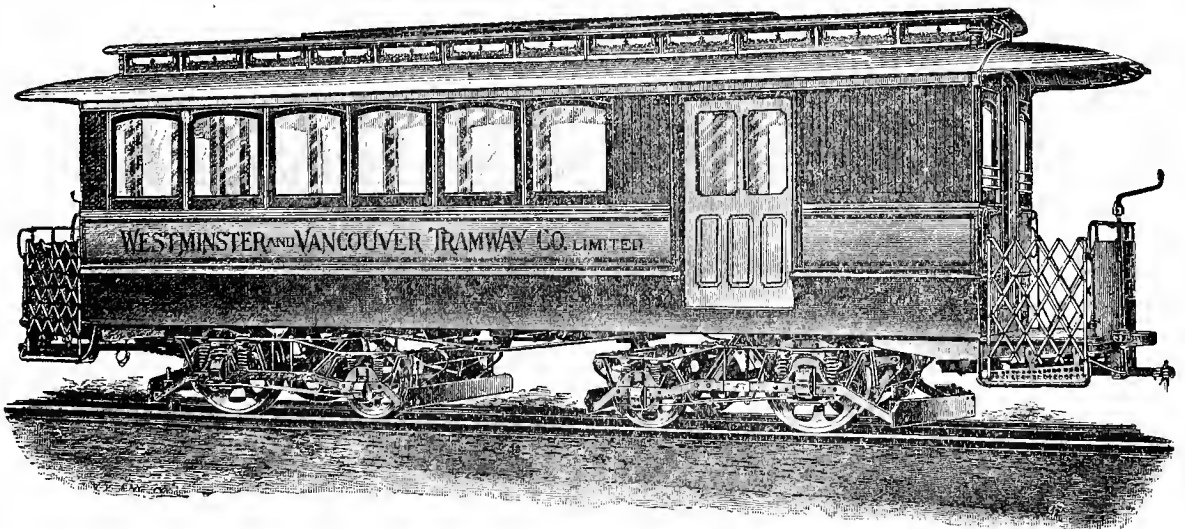

Twenty-five feet Combination Passenger and Baggage Car, having 10-ft. baggage room and 15-ft. passenger compartment. Finish can be No. 1, 2 or 3, as desired. Mounted on Brill Eureka Maximum-Traction Trucks.

COMBINATION OPEN AND CLOSED CAR

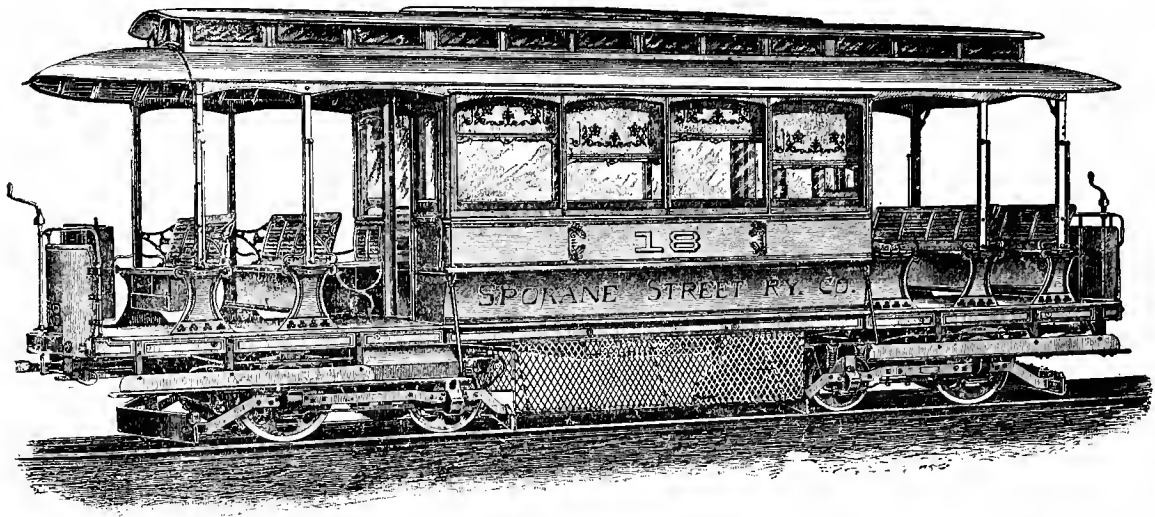

Twenty-nine feet Combination Open and Closed Car, mounted on Brill's Eureka Trucks. Seating capacity, as shown, 40 persons; but compartments can be made any desired length and finish, either 1, 2 or 3.

PRIVATE CAR

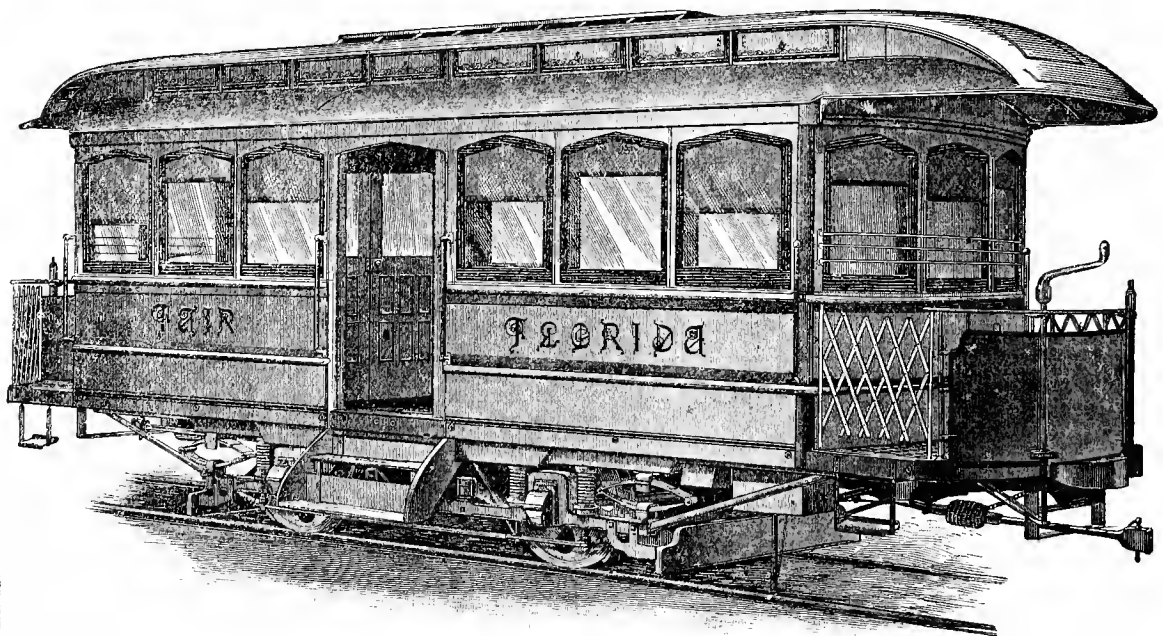

Private Car, 20 ft. long, and divided into two compartments, 5 ft. and 15 ft respectively; the smaller as a smoking room, the latter as a drawing room. Finished most luxuriously with carpeted floors, easy chairs, handsomely cushioned, silk curtain drapery, upholstered divans, etc mounted on Brill No. 21 Trucks. Operated on the line of the Consumers' Elec. Ry., Tampa, Fla.

